

SCHAUM'S
Solved Problems Series

3000
SOLVED PROBLEMS IN

PHYSICS

- ✓ Demonstrates the best problem-solving strategies
- ✓ Gives you more solved problems than any other guide
- ✓ Helps cut study time
- ✓ Improves performance on exams
- ✓ Provides subject coverage so thorough, graduates students and professionals can use this guide, too

**OVER
30 MILLION
SCHAUM'S SOLD
WORLDWIDE**

ALVIN HALPERN, Ph.D



Tặng các độc giả của www.thuvienvatly.info

Hic, tập sách này do **hiepkhachquay** “môi ruột”
google books từ một tiệm net dành cho trẻ em
và đóng gói thành file PDF tại Kiên Giang.

Tập sách này không đầy đủ, vì ngài google có bao giờ cho đọc
trọn vẹn một tác phẩm nào đâu.

Hi vọng bà con ta khai thác có hiệu quả tập sách này.

Mọi góp ý vui lòng liên hệ nghiemth17617@kiengiang.edu.vn

Nitin M Sir

CONTENTS

CHAPTER SKELETONS WITH EXAMS	ix
Chapter 1 MATHEMATICAL INTRODUCTION	1
1.1 Planar Vectors, Scientific Notation, and Units / 1.2 Three-Dimensional Vectors; Dot and Cross Products	
Chapter 2 EQUILIBRIUM OF CONCURRENT FORCES	21
2.1 Ropes, Knots, and Frictionless Pulleys / 2.2 Friction and Inclined Planes / 2.3 Graphical and Other Problems	
Chapter 3 KINEMATICS IN ONE DIMENSION	36
3.1 Dimensions and Units; Constant-Acceleration Problems	
Chapter 4 NEWTON'S LAWS OF MOTION	51
4.1 Force, Mass, and Acceleration / 4.2 Friction; Inclined Planes; Vector Notation / 4.3 Two-Object and Other Problems	
Chapter 5 MOTION IN A PLANE I	76
5.1 Projectile Motion / 5.2 Relative Motion	
Chapter 6 MOTION IN A PLANE II	94
6.1 Circular Motion; Centripetal Force / 6.2 Law of Universal Gravitation; Satellite Motion / 6.3 General Motion in a Plane	
Chapter 7 WORK AND ENERGY	111
7.1 Work Done by a Force / 7.2 Work, Kinetic Energy, and Potential Energy / 7.3 Conservation of Mechanical Energy / 7.4 Additional Problems	
Chapter 8 POWER AND SIMPLE MACHINES	136
8.1 Power / 8.2 Simple Machines	
Chapter 9 IMPULSE AND MOMENTUM	146
9.1 Elementary Problems / 9.2 Elastic Collisions / 9.3 Inelastic Collisions and Ballistic Pendulums / 9.4 Collisions in Two Dimensions / 9.5 Recoil and Reaction / 9.6 Center of Mass (see also Chap. 10)	
Chapter 10 STATICS OF RIGID BODIES	176
10.1 Equilibrium of Rigid Bodies / 10.2 Center of Mass (Center of Gravity)	
Chapter 11 ROTATIONAL MOTION I: KINEMATICS AND DYNAMICS	207
11.1 Angular Motion and Torque / 11.2 Rotational Kinematics / 11.3 Torque and Rotation / 11.4 Moment of Inertia / 11.5 Translational–Rotational Relationships / 11.6 Problems Involving Cords Around Cylinders, Rolling Objects, etc.	
Chapter 12 ROTATIONAL MOTION II: KINETIC ENERGY, ANGULAR IMPULSE, ANGULAR MOMENTUM	228
12.1 Energy and Power / 12.2 Angular Impulse; the Physical Pendulum / 12.3 Angular Momentum	
Chapter 13 MATTER IN BULK	247
13.1 Density and Specific Gravity / 13.2 Elastic Properties	

Chapter 14	SIMPLE HARMONIC MOTION 14.1 Oscillations of a Mass on a Spring / 14.2 SHM of Pendulums and Other Systems	256
Chapter 15	HYDROSTATICS 15.1 Pressure and Density / 15.2 Pascal's and Archimedes' Principles; Surface Tension	271
Chapter 16	HYDRODYNAMICS 16.1 Equation of Continuity, Bernoulli's Equation, Torricelli's Theorem / 16.2 Viscosity, Stokes' Law, Poiseuille's Law, Turbulence, Reynolds Number	285
Chapter 17	TEMPERATURE AND THERMAL EXPANSION 17.1 Temperature Scales; Linear Expansion / 17.2 Area and Volume Expansion	297
Chapter 18	HEAT AND CALORIMETRY 18.1 Heat and Energy; Mechanical Equivalent of Heat / 18.2 Calorimetry, Specific Heats, Heats of Fusion and Vaporization	307
Chapter 19	HEAT TRANSFER 19.1 Conduction / 19.2 Convection / 19.3 Radiation	316
Chapter 20	GAS LAWS AND KINETIC THEORY 20.1 The Mole Concept; the Ideal Gas Law / 20.2 Kinetic Theory / 20.3 Atmospheric Properties; Specific Heats of Solids	326
Chapter 21	THE FIRST LAW OF THERMODYNAMICS 21.1 Basic Thermodynamic Concepts / 21.2 The First Law of Thermodynamics, Internal Energy, p - V Diagrams, Cyclical Systems	345
Chapter 22	THE SECOND LAW OF THERMODYNAMICS 22.1 Heat Engines; Kelvin – Planck and Clausius Statements of the Second Law / 22.2 Entropy	357
Chapter 23	WAVE MOTION 23.1 Characteristic Properties / 23.2 Standing Waves and Resonance	366
Chapter 24	SOUND 24.1 Sound Velocity; Beats; Doppler Shift / 24.2 Power, Intensity, Reverberation Time, Shock Waves	379
Chapter 25	COULOMB'S LAW AND ELECTRIC FIELDS 25.1 Coulomb's Law of Electrostatic Force / 25.2 The Electric Field; Continuous Charge Distributions; Motion of Charged Particles in an Electric Field / 25.3 Electric Flux and Gauss's Law	387
Chapter 26	ELECTRIC POTENTIAL AND CAPACITANCE 26.1 Potential Due to Point Charges or Charge Distributions / 26.2 The Potential Function and the Associated Electric Field / 26.3 Energetics; Problems with Moving Charges / 26.4 Capacitance and Field Energy / 26.5 Capacitors in Combination	407
Chapter 27	SIMPLE ELECTRIC CIRCUITS 27.1 Ohm's Law, Current, Resistance / 27.2 Resistors in Combination / 27.3 EMF and Electrochemical Systems / 27.4 Electric Measurement / 27.5 Electric Power / 27.6 More Complex Circuits, Kirchhoff's Circuit Rules, Circuits with Capacitance	432
Chapter 28	THE MAGNETIC FIELD 28.1 Force on a Moving Charge / 28.2 Force on an Electric Current / 28.3 Torque and Magnetic Dipole Moment / 28.4 Sources of the Magnetic Field; Law of Biot and Savart / 28.5 More Complex Geometries; Ampère's Law	467

Chapter 29	MAGNETIC PROPERTIES OF MATTER 29.1 The H and M Fields; Susceptibility; Relative Permeability / 29.2 Magnets; Pole Strength	510
Chapter 30	INDUCED EMF: GENERATORS AND MOTORS 30.1 Change in Magnetic Flux, Faraday's Law, Lenz's Law / 30.2 Motional EMF; Induced Currents and Forces / 30.3 Time-Varying Magnetic and Induced Electric Fields / 30.4 Electric Generators and Motors	526
Chapter 31	INDUCTANCE 31.1 Self-Inductance / 31.2 Mutual Inductance: The Ideal Transformer	552
Chapter 32	ELECTRIC CIRCUITS 32.1 R - C , R - L , L - C and R - L - C Circuits; Time Response / 32.2 AC Circuits in the Steady State / 32.3 Time Behavior of AC Circuits	566
Chapter 33	ELECTROMAGNETIC WAVES 33.1 Displacement Current, Maxwell's Equations, the Speed of Light / 33.2 Mathematical Description of Waves in One and Three Dimensions / 33.3 The Component Fields of an Electromagnetic Wave; Induced EMF / 33.4 Energy and Momentum Fluxes	590
Chapter 34	LIGHT AND OPTICAL PHENOMENA 34.1 Reflection and Refraction / 34.2 Dispersion and Color / 34.3 Photometry and Illumination	607
Chapter 35	MIRRORS, LENSES, AND OPTICAL INSTRUMENTS 35.1 Mirrors / 35.2 Thin Lenses / 35.3 Lensmaker's Equation; Composite Lens Systems / 35.4 Optical Instruments: Projectors, Cameras, the Eye / 35.5 Optical Instruments: Microscopes and Telescopes	634
Chapter 36	INTERFERENCE, DIFFRACTION, AND POLARIZATION 36.1 Interference of Light / 36.2 Diffraction and the Diffraction Grating / 36.3 Polarization of Light	668
Chapter 37	SPECIAL RELATIVITY 37.1 Lorentz Transformation, Length Contraction, Time Dilation, and Velocity Transformation / 37.2 Mass-Energy Relation; Relativistic Dynamics	688
Chapter 38	PARTICLES OF LIGHT AND WAVES OF MATTER 38.1 Photons and the Photoelectric Effect / 38.2 Compton Scattering; X-rays; Pair Production and Annihilation / 38.3 de Broglie Waves and the Uncertainty Principle	708
Chapter 39	MODERN PHYSICS: ATOMS, NUCLEI, SOLID-STATE ELECTRONICS 39.1 Atoms and Molecules / 39.2 Nuclei and Radioactivity / 39.3 Solid-State Electronics	720
	INDEX	737

TO THE STUDENT

This book is intended for use by students of general physics, either in calculus- or noncalculus-based courses. Problems requiring real calculus (not merely calculus notation) are marked with a small superscript c .

The only way to master general physics is to gain ability and sophistication in problem-solving. This book is meant to make you a master of the art — and should do so if used properly. As a rule, a problem can be solved once you have learned the ideas behind it; sometimes these very ideas are brought into sharper focus by looking at sample problems and their solutions. If you have difficulty with a topic, you can select a few problems in that area, examine the solutions carefully, and then try to solve related problems before looking at the printed solutions.

There are numerous ways of posing a problem and, frequently, numerous ways of solving one. You should try to gain understanding of how to approach various classes of problems, rather than memorizing particular solutions. Understanding is better than memory for success in physics.

The problems in this book cover every important topic in a typical two- or three-semester general physics sequence. Ranging from the simple to the complex, they will provide you with plenty of practice and food for thought.

The *Chapter Skeletons with Exams*, beginning on the next page, was devised to help students with limited time gain maximum benefit from this book. It is hoped that the use of this feature is self-evident; still, the following remarks may help:

- The *Chapter Skeletons* divide the problems in this book into three categories: SCAN, HOMEWORK and EXAMS. (Turn to page ix to see an example.)
- To gain a quick overview of the basic ideas in a chapter, review the SCAN problems and study their printed solutions.
- HOMEWORK problems are for practicing your problem-solving skills; *cover the solution with an index card* as you read, and try to solve, the problem. Do *both sets* if your course is calculus based.
- No problem from SCAN or HOMEWORK is duplicated in EXAMS, and no two Exams overlap. Calculus-based students are urged also to take the Hard Exam. Exams run about 60 minutes, unless otherwise indicated.
- Still further problems constitute the two groups of Final Exams. Stay in your category(ies), and good luck.

CHAPTER SKELETONS WITH EXAMS

Chapter 1

S C A N		1.1, 1.2, 1.3, 1.4, 1.5, 1.6, 1.12, 1.13, 1.14, 1.15, 1.27, 1.60, 1.61, 1.83, 1.84, 1.85, 1.89, 1.90
H O M E W O R K	Everybody	1.8, 1.11, 1.16, 1.18, 1.23, 1.26, 1.31, 1.33, 1.35, 1.41, 1.42, 1.48, 1.50, 1.53, 1.65, 1.68, 1.74, 1.86, 1.92
	Calc.-based only	1.51, 1.53, 1.56, 1.57, 1.59, 1.75, 1.76, 1.77, 1.80, 1.81, 1.87, 1.93
E X A M S	Easy	1.10, 1.21, 1.39, 1.54
	Hard	1.40, 1.49, 1.67, 1.86
	Calc.-based only	1.58, 1.72, 1.88, 1.91

Chapter 2

S C A N		2.1, 2.2, 2.4, 2.12, 2.27, 2.28, 2.29 2.38
	Everybody	2.5, 2.6, 2.21, 2.25, 2.31, 2.32, 2.39
H O M E W O R K	Calc.-based only	2.14, 2.20, 2.23, 2.36, 2.40
	Easy	2.3, 2.7, 2.30, 2.40
E X A M S	Hard	2.15, 2.24, 2.33, 2.44
	Calc.-based only	2.16, 2.22, 2.37, 2.43

Chapter 3

S C A N		3.2, 3.4, 3.8, 3.19, 3.23, 3.29, 3.36, 3.37
	Everybody	3.5, 3.12, 3.16, 3.21, 3.28, 3.39, 3.41, 3.46, 3.49, 3.53
H O M E W O R K	Calc.-based only	3.7, 3.24, 3.38, 3.45, 3.55, 3.59, 3.60, 3.61
	Easy	3.10, 3.26, 3.40, 3.51
E X A M S	Hard	3.25, 3.30, 3.48, 3.52
	Calc.-based only	3.33, 3.54, 3.62

Chapter 4

S C A N		4.1, 4.2, 4.3, 4.4, 4.14, 4.16, 4.28, 4.37, 4.39, 4.66, 4.73, 4.93
H O M E W O R K	Everybody	4.5, 4.7, 4.15, 4.22, 4.38, 4.40, 4.45, 4.68, 4.69, 4.75
	Calc.-based only	4.31, 4.50, 4.52, 4.53, 4.58, 4.61, 4.72, 4.81, 4.97
E X A M S	Easy	4.10, 4.43, 4.77, 4.79
	Hard	4.17, 4.46, 4.80, 4.85, 4.86
	Calc.-based only	4.34, 4.54, 4.74, 4.95 (60 - 70 min.)

Chapter 5

S C A N		5.1, 5.5, 5.6, 5.10, 5.19, 5.34, 5.37, 5.52
H O M E W O R K	Everybody	5.2, 5.9, 5.14, 5.20, 5.38, 5.53
	Calc.-based only	5.31, 5.35, 5.40, 5.41, 5.44, 5.60
E X A M S	Easy	5.3, 5.21, 5.24, 5.51
	Hard	5.7, 5.8, 5.11, 5.22, 5.54 (60 - 70 min.)
	Calc.-based only	5.16, 5.18, 5.43, 5.59 (60 - 70 min.)

Chapter 6

S C A N	6.1, 6.7, 6.15, 6.21, 6.25, 6.27, 6.33	
	Everybody	6.11, 6.18, 6.22, 6.29, 6.37, 6.42
H O M E W O R K	Calc.-based only	6.41, 6.45, 6.46, 6.50, 6.51, 6.55
	Easy	6.2, 6.4, 6.23, 6.31
E X A M S	Hard	6.9, 6.14, 6.28, 6.35
	Calc.-based only	6.16, 6.44, 6.47, 6.49

Chapter 7

S C A N	7.1, 7.4, 7.5, 7.8, 7.18, 7.29, 7.30, 7.32, 7.41, 7.43, 7.53, 7.61, 7.62, 7.67, 7.79, 7.83	
	Everybody	7.9, 7.10, 7.14, 7.20, 7.33, 7.42, 7.48, 7.50, 7.51, 7.69, 7.75, 7.82, 7.84, 7.87, 7.92, 7.98
H O M E W O R K	Calc.-based only	7.17, 7.26, 7.35, 7.71, 7.76, 7.93, 7.105, 7.107, 7.110, 7.114, 7.117
	Easy	7.19, 7.37, 7.65, 7.70, 7.88
E X A M S	Hard	7.44, 7.45, 7.73, 7.77, 7.80
	Calc.-based only	7.74, 7.91, 7.106, 7.113

Chapter 8

S C A N		8.1, 8.2, 8.8, 8.19, 8.20, 8.21, 8.22, 8.24, 8.34
H O M E W O R K	Everybody	8.3, 8.5, 8.11, 8.13, 8.25, 8.28, 8.33
	Calc.-based only	8.10, 8.18, 8.27, 8.31
E X A M S	Easy	8.6, 8.7, 8.23, 8.36, 8.37
	Hard	8.9, 8.15, 8.29, 8.38
	Calc.-based only	8.12, 8.17, 8.30, 8.35

Chapter 9

S C A N		9.2, 9.4, 9.10, 9.16, 9.17, 9.19, 9.32, 9.54, 9.68, 9.87
H O M E W O R K	Everybody	9.5, 9.23, 9.24, 9.34, 9.56, 9.59, 9.70, 9.88, 9.95
	Calc.-based only	9.13, 9.27, 9.47, 9.50, 9.79, 9.97 9.104
E X A M S	Easy	9.18, 9.55, 9.73, 9.98 (60 - 70 min.)
	Hard	9.39, 9.57, 9.69, 9.102 (60 - 70 min.)
	Calc.-based only	9.60, 9.85, 9.103, 9.106 (60 - 70 min.)

Chapter 10

S C A N		10.1, 10.7, 10.14, 10.32, 10.37, 10.44, 10.48 (also 9.107)
	Everybody	10.2, 10.8, 10.15, 10.33, 10.47, 10.58, 10.60 (also 9.113)
H O M E W O R K	Calc.-based only	10.10, 10.31, 10.64, 10.65, 10.66, 10.75, 10.79 (also 9.120)
	Easy	10.17, 10.20, 10.39, 10.67
E X A M S	Hard	10.22, 10.34, 10.38, 10.118
	Calc.-based only	10.24, 10.52, 10.57, 10.77 (60 - 70 min.)

Chapter 11

S C A N		11.10, 11.21, 11.26, 11.34, 11.52, 11.68, 11.72, 11.82
	Everybody	11.12, 11.22, 11.30, 11.35, 11.53, 11.69, 11.78, 11.83
H O M E W O R K	Calc.-based only	11.8, 11.40, 11.44, 11.46, 11.62, 11.75, 11.79, 11.84
	Easy	11.23, 11.28, 11.59, 11.73
E X A M S	Hard	11.37, 11.60, 11.81, 11.87
	Calc.-based only	11.45, 11.66, 11.76, 11.88

Chapter 12

S C A N	12.3, 12.6, 12.8, 12.12, 12.19, 12.28, 12.50, 12.56	
	Everybody	12.2, 12.4, 12.11, 12.14, 12.20, 12.29, 12.52, 12.62
H O M E W O R K	Calc.-based only	12.15, 12.25, 12.34, 12.37, 12.49, 12.65, 12.69, 12.71
	Easy	12.9, 12.17, 12.31, 12.58
E X A M S	Hard	12.13, 12.23, 12.30, 12.59
	Calc.-based only	12.24, 12.43, 12.57, 12.72 (60 - 70 min.)

Chapter 13

S C A N	13.1, 13.2, 13.16, 13.17, 13.18, 13.19, 13.20, 13.21	
	Everybody	13.5, 13.11, 13.22, 13.33, 13.43, 13.46
H O M E W O R K	Calc.-based only	13.34, 13.50
	Easy	13.7, 13.25, 13.38, 13.45
E X A M S	Hard	13.10, 13.32, 13.44, 13.47
	Calc.-based only	13.15, 13.36, 13.48, 13.51

Chapter 14

S C A N		14.1, 14.7, 14.11, 14.18, 14.27, 14.36, 14.44, 14.56
H O M E W O R K	Everybody	14.3, 14.9, 14.13, 14.21, 14.22, 14.37, 14.46, 14.58
	Calc.-based only	14.32, 14.34, 14.41, 14.47, 14.52, 14.59
E X A M S	Easy	14.17, 14.23, 14.24, 14.45, 14.54
	Hard	14.19, 14.20, 14.55, 14.57
	Calc.-based only	14.30, 14.35, 14.42, 14.53

Chapter 15

S C A N		15.1, 15.7, 15.14, 15.23, 15.39, 15.43, 15.49, 15.64
H O M E W O R K	Everybody	15.2, 15.8, 15.17, 15.24, 15.40, 15.44, 15.50, 15.63
	Calc.-based only	15.5, 15.26, 15.35, 15.36, 15.59
E X A M S	Easy	15.19, 15.41, 15.54, 15.65
	Hard	15.31, 15.32, 15.42, 15.58, 15.66
	Calc.-based only	15.27, 15.28, 15.62, 15.67 (60 - 70 min.)

Chapter 16

S C A N	16.1, 16.2, 16.3, 16.4, 16.5, 16.10, 16.15, 16.31, 16.40	
	Everybody	16.7, 16.10, 16.12, 16.16, 16.18, 16.34, 16.41
H O M E W O R K	Calc.-based only	16.8, 16.27, 16.32, 16.33, 16.44, 16.45
	Easy	16.6, 16.13, 16.24, 16.37
E X A M S	Hard	16.18, 16.18, 16.20, 16.29, 16.43
	Calc.-based only	16.17, 16.22, 16.26, 16.51

Chapters 17 and 18

S C A N	17.1, 17.8, 17.14, 17.38, 18.2, 18.16, 18.24, 18.26, 18.39	
	Everybody	17.2, 17.11, 17.20, 17.36, 18.5, 18.19, 18.27, 18.35, 18.46
H O M E W O R K	Calc.-based only	17.18, 17.28, 17.29, 18.12, 18.45
	Easy	17.10, 17.37, 18.17, 18.33
E X A M S	Hard	17.15, 17.40, 18.6, 18.36
	Calc.-based only	17.23, 17.44, 18.48, 18.51

Chapter 19

S C A N		19.1, 19.2, 19.7, 19.30, 19.31, 19.32, 19.38, 19.39, 19.40
H O M E W O R K	Everybody	19.3, 19.10, 19.15, 19.33, 19.34, 19.41
	Calc.-based only	19.17, 19.20, 19.22, 19.28
E X A M S	Easy	19.8, 19.13, 19.35, 19.44
	Hard	19.11, 19.14, 19.36, 19.48
	Calc.-based only	19.25, 19.29, 19.37, 19.50

Chapter 20

S C A N		20.1, 20.2, 20.7, 20.9, 20.20, 20.35, 20.37, 20.40, 20.45, 20.70
H O M E W O R K	Everybody	20.3, 20.8, 20.10, 20.22, 20.31, 20.32, 20.43, 20.48, 20.71, 20.73
	Calc.-based only	20.26, 20.38, 20.41, 20.55, 20.56, 20.62, 20.68, 20.82, 20.86
E X A M S	Easy	20.17, 20.25, 20.43, 20.74
	Hard	20.24, 20.27, 20.53, 20.77, 20.78
	Calc.-based only	20.44, 20.59, 20.69, 20.89 (60 - 70 min.)

Chapters 21 and 22

S C A N		21.1, 21.2, 21.3, 21.4, 21.6, 21.27, 21.42, 22.1, 22.2, 22.3, 22.4, 22.6, 22.14, 22.23
H O M E W O R K	Everybody	21.5, 21.6, 21.23, 21.30, 21.31, 21.46, 22.5, 22.8, 22.15, 22.24, 22.30
	Calc.-based only	21.14, 21.20, 21.26, 21.39, 21.40, 22.9, 22.18, 22.19
E X A M S	Easy	21.16, 21.29, 21.47, 22.11
	Hard	21.23, 21.34, 22.13, 22.25
	Calc.-based only	21.15, 21.45, 22.21, 22.28 (60 - 70 min.)

Final Exams for Chapters 1-22 (160 - 180 min.)

Easy A 1.47, 3.34, 5.23, 7.102, 10.18, 11.27, 13.39,
15.21, 15.22, 18.40, 20.15

Easy B 2.35, 4.90, 6.5, 8.32, 9.57, 12.51, 14.38, 16.23,
19.42, 21.35

Hard A 1.78, 3.44, 5.58, 7.99, 10.42, 12.61, 13.37, 16.21,
18.47, 20.28

Hard B 2.17, 4.91, 6.32, 7.111, 9.101, 11.54, 14.39, 15.53,
19.46, 22.7

Calc. A 1.79, 3.56, 6.20, 6.56, 7.116, 10.79, 12.70, 15.30,
17.40, 20.91

Calc. B 2.41, 4.78, 5.49, 6.58, 7.120, 9.61, 14.28, 14.29,
16.46, 19.49, 22.27

Chapters 23 and 24

S C A N		23.1, 23.4, 23.7, 23.8, 23.18, 23.24, 23.41, 23.51, 24.1, 24.11, 24.12, 24.16, 24.28
H O M E W O R K	Everybody	23.2, 23.5, 23.19, 23.21, 23.25, 23.42, 23.54, 24.2, 24.14, 24.18, 24.20, 24.33
	Calc.-based only	23.27, 23.29, 23.34, 23.37, 24.15, 24.19, 24.25, 24.26, 24.34, 24.39
E X A M S	Easy	23.6, 23.46, 24.13, 24.29
	Hard	23.20, 23.47, 24.24, 24.32
	Calc.-based only	23.36, 23.56, 24.21, 24.38

Chapter 25

S C A N		25.1, 25.2, 25.3, 25.5, 25.11, 25.16, 25.29, 25.32, 25.46, 25.59, 25.64
H O M E W O R K	Everybody	25.8, 25.12, 25.14, 25.18, 25.34, 25.36, 25.48, 25.60, 25.62, 25.68
	Calc.-based only	25.38, 25.39, 25.44, 25.53, 25.54, 25.57, 25.58, 25.61
E X A M S	Easy	25.15, 25.35, 25.45, 25.63
	Hard	25.20, 25.31, 25.50, 25.69
	Calc.-based only	25.23, 25.42, 25.65, 25.71, 25.72

Chapter 26

S C A N		26.1, 26.2, 26.4, 26.6, 26.8, 26.15, 26.33, 26.52, 26.53, 26.58, 26.64, 26.67, 26.75, 26.90, 26.91, 26.98
	Everybody	26.6, 26.7, 26.9, 26.16, 26.19, 26.20, 26.35, 26.59, 26.62, 26.65, 26.76, 26.80, 26.82, 26.93, 26.99
H O M E W O R K	Calc.-based only	26.3, 26.5, 26.21, 26.25, 26.26, 26.27, 26.39, 26.43, 26.47, 26.63, 26.66, 26.68, 26.85, 26.86, 26.106
	Easy	26.17, 26.32, 26.60, 26.92, 26.95
E X A M S	Hard	26.18, 26.36, 26.50, 26.101, 26.102
	Calc.-based only	26.24, 26.29, 26.37, 26.109 (60 - 70 min.)

Chapter 27

S C A N		27.1, 27.2, 27.4, 27.5, 27.11, 27.31, 27.38, 27.41, 27.49, 27.50, 27.55, 27.64, 27.65, 27.66, 27.67, 27.68, 27.69, 27.81, 27.82, 27.89, 27.92, 27.94, 27.95, 27.120
	Everybody	27.6, 27.13, 27.21, 27.25, 27.33, 27.43, 27.47, 27.51, 27.56, 27.70, 27.74, 27.83, 27.90, 27.99, 27.102, 27.117, 27.121
H O M E W O R K	Calc.-based only	27.3, 27.17, 27.18, 27.36, 27.87, 27.113, 27.124, 27.125, 27.126, 27.131, 27.141, 27.142
	Easy	27.10, 27.42, 27.59, 27.104
E X A M S	Hard	27.15, 27.46, 27.60, 27.105
	Calc.-based only	27.37, 27.80, 27.136, 27.145

Chapter 28

S C A N		28.1, 28.2, 28.3, 28.9, 28.30, 28.33, 28.43, 28.54, 28.62, 28.64, 28.87, 28.89, 28.90, 28.143
H O M E W O R K	Everybody	28.4, 28.6, 28.19, 28.34, 28.45, 28.65, 28.66, 28.68, 28.76, 28.92, 28.105, 28.106, 28.119, 28.134, 23.144, 28.146
	Calc.-based only	28.26, 28.49, 28.50, 28.60, 28.70, 28.72, 28.73, 28.82, 28.88, 28.112, 28.122, 28.131, 28.138
E X A M S	Easy	28.38, 28.47, 28.69, 28.94, 28.136
	Hard	28.24, 28.57, 28.77, 28.117
	Calc.-based only	28.21, 28.81, 28.118, 28.141 (60 - 70 min.)

Chapter 29

S C A N		29.1, 29.2, 29.3, 29.4, 29.20, 29.21, 29.24, 29.27, 29.34, 29.35, 29.36, 29.40, 29.43, 29.47
H O M E W O R K	Everybody	29.6, 29.9, 29.10, 29.16, 29.17, 29.30, 29.36, 29.37, 29.38, 29.44, 29.45, 29.46, 29.50
	Calc.-based only	29.5, 29.27, 29.28, 29.29, 29.32, 29.39, 29.48
E X A M S	Easy	29.7, 29.8, 29.18, 29.45, 29.55
	Hard	29.14, 29.25, 29.49, 29.55
	Calc.-based only	29.22, 29.23, 29.41, 29.51

Chapter 30

S C A N		30.1, 30.2, 30.11, 30.15, 30.21, 30.30, 30.31, 30.35, 30.66, 30.67, 30.74, 30.77 30.78, 30.80, 30.92, 30.100
	Everybody	30.4, 30.8, 30.12, 30.13, 30.16, 30.22, 30.39, 30.49, 30.50, 30.65, 30.76, 30.79, 30.83, 30.93, 30.102
H O M E W O R K	Calc.-based only	30.5, 30.14, 30.32, 30.37, 30.40, 30.44, 30.53, 30.64, 30.71, 30.110
	Easy	30.19, 30.36, 30.82, 30.108
E X A M S	Hard	30.17, 30.18, 30.38, 30.48, 30.86
	Calc.-based only	30.41, 30.54, 30.75, 30.105

Chapter 31

S C A N		31.1, 31.2, 31.10, 31.13, 31.26, 31.29, 31.30, 31.31, 31.38, 31.42, 31.59
	Everybody	31.4, 31.5, 31.14, 31.18, 31.27, 31.32, 31.33, 31.40, 31.60
H O M E W O R K	Calc.-based only	31.3, 31.15, 31.17, 31.25, 31.46, 31.48, 31.49, 31.53, 31.56
	Easy	31.6, 31.20, 31.35, 31.40
E X A M S	Hard	31.11, 31.21, 31.37, 31.44
	Calc.-based only	31.6, 31.28, 31.52, 31.54 (60 - 70 min.)

Chapter 32

S C A N		32.1, 32.2, 32.9, 32.10, 32.20, 32.34, 32.35, 32.37, 32.38, 32.39, 32.40, 32.42, 32.56, 32.57, 32.58, 32.77
	Everybody	32.4, 32.7, 32.13, 32.21, 32.24, 32.36 32.41, 32.43, 32.50, 32.54, 32.60, 32.61, 32.81
H O M E W O R K	Calc.-based only	32.6, 32.15, 32.17, 32.23, 32.28, 32.30, 32.85, 32.86, 32.87, 32.91
	Easy	32.3, 32.12, 32.72, 32.74
E X A M S	Hard	32.11, 32.25, 32.65, 32.66
	Calc.-based only	32.8, 32.31, 32.84, 32.94

Chapter 33

S C A N		33.8, 33.9, 33.17, 33.22, 33.30, 33.37, 33.44, 33.54, 33.55, 33.57, 33.69
	Everybody	33.10, 33.19, 33.33, 33.45, 33.46, 33.50, 33.58, 33.70
H O M E W O R K	Calc.-based only	33.1, 33.2, 33.4, 33.5, 33.6, 33.14, 33.28, 33.40, 33.41
	Easy	33.11, 33.35, 33.36, 33.56, 33.61
E X A M S	Hard	33.20, 33.38, 33.48, 33.71
	Calc.-based only	33.15, 33.42, 33.49, 33.53

Chapter 34

S C A N		34.1, 34.2, 34.10, 34.15, 34.24, 34.26, 34.33, 34.43, 34.45, 34.56, 34.58, 34.69, 34.71, 34.80, 34.81, 34.85, 34.88, 34.91
H O M E W O R K	Everybody	34.5, 34.13, 34.16, 34.21, 34.27, 34.37, 34.41, 34.44, 34.52, 34.59, 34.72, 34.82, 34.89, 34.90, 34.94
	Calc.-based only	34.6, 34.53, 34.54, 34.57, 34.64, 34.73, 34.77
E X A M S	Easy	34.11, 34.16, 34.63, 34.96
	Hard	34.14, 34.60, 34.83, 34.101
	Calc.-based only	34.55, 34.65, 34.74, 34.102

Chapter 35

S C A N		35.1, 35.2, 35.3, 35.4, 35.5, 35.15, 35.16, 35.22, 35.35, 35.46, 35.47, 35.48, 35.49, 35.54, 35.58, 35.67, 35.88, 35.96, 35.100, 35.106, 35.107, 35.112, 35.125, 35.130
H O M E W O R K	Everybody	35.6, 35.9, 35.12, 35.17, 35.18, 35.21, 35.33, 35.37, 35.50, 35.51, 35.52, 35.55, 35.57, 35.68, 35.74, 35.82, 35.87, 35.94, 35.97, 35.108, 35.113, 35.127, 35.133, 35.134
	Calc.-based only	35.10, 35.13, 35.43, 35.45, 35.64, 35.65, 35.78, 35.86, 35.121, 35.123
E X A M S	Easy	35.19, 35.39, 35.61, 35.111
	Hard	35.11, 35.23, 35.114, 35.132
	Calc.-based only	35.7, 35.34, 35.80, 35.129 (60 - 70 min.)

Chapter 36

S C A N		36.5, 36.6, 36.11, 36.28, 36.30, 36.33, 36.35, 36.50, 36.51, 36.56, 36.58, 36.66, 36.67
H O M E W O R K	Everybody	36.7, 36.15, 36.24, 36.31, 36.34, 36.37, 36.41, 36.52, 36.54, 36.59, 36.63, 36.65
	Calc.-based only	36.1, 36.20, 36.22, 36.26, 36.40, 36.42, 36.48, 36.62, 36.70, 36.74
E X A M S	Easy	36.8, 36.29, 36.36, 36.44, 36.53
	Hard	36.12, 36.25, 36.43, 36.53
	Calc.-based only	36.19, 36.27, 36.47, 36.72, 36.75

Chapter 37

S C A N		37.1, 37.3, 37.4, 37.13, 37.14, 37.21, 37.30, 37.47, 37.50, 37.51, 37.58
H O M E W O R K	Everybody	37.2, 37.5, 37.7, 37.15, 37.16, 37.18, 37.19, 37.24, 37.48, 37.53, 37.62, 37.64
	Calc.-based only	37.10, 37.11, 37.26, 37.32, 37.34, 37.36, 37.56, 37.65
E X A M S	Easy	37.12, 37.22, 37.28, 37.49, 37.52, 37.57
	Hard	37.6, 37.8, 37.31, 37.55
	Calc.-based only	37.27, 37.37, 37.59, 37.66 (60 - 70 min.)

Chapter 38

S C A N		38.1, 38.2, 38.18, 38.19, 38.23, 38.29, 38.37, 38.41, 38.43, 38.53, 38.66
	Everybody	38.3, 38.10, 38.17, 38.18, 38.24, 38.30, 38.38, 38.42, 38.44, 38.52, 38.56, 38.67
H O M E W O R K	Calc.-based only	38.9, 38.26, 38.33, 38.36, 38.47, 38.49, 38.58, 38.61, 38.62, 38.65, 38.71
	Easy	38.8, 38.25, 38.34, 38.54
E X A M S	Hard	38.22, 38.31, 38.57, 38.68
	Calc.-based only	38.14, 38.15, 38.32, 38.51, 38.55 (60 - 70 min.)

Chapter 39

S C A N		39.1, 39.4, 39.13, 39.14, 39.15, 39.30, 39.33, 39.38, 39.39, 39.42, 39.48, 39.54, 39.57, 39.64, 39.67, 39.73, 39.75, 39.76, 39.83
	Everybody	39.3, 39.5, 39.16, 39.18, 39.28, 39.34, 39.40, 39.43, 39.44, 39.50, 39.53, 39.55, 39.58, 39.61, 39.68, 39.81
H O M E W O R K	Calc.-based only	39.20, 39.23, 39.25, 39.27, 39.32, 39.36, 39.37, 39.46, 39.65, 39.72, 39.77, 39.78, 39.84
	Easy	39.8, 39.41, 39.49, 39.62
E X A M S	Hard	39.10, 39.21, 39.29, 39.60
	Calc.-based only	39.12, 39.17, 39.26, 39.52 (60 - 70 min.)

CHAPTER 1

Mathematical Introduction

1.1 PLANAR VECTORS, SCIENTIFIC NOTATION, AND UNITS

1.1 What is a scalar quantity?

| A scalar quantity has only magnitude; it is a pure number, positive or negative. Scalars, being simple numbers, are added, subtracted, etc., in the usual way. It may have a unit after it, e.g. mass = 3 kg.

1.2 What is a vector quantity?

| A vector quantity has both magnitude and direction. For example, a car moving south at 40 km/h has a *vector velocity* of 40 km/h southward.

A vector quantity can be represented by an arrow drawn to scale. The length of the arrow is proportional to the magnitude of the vector quantity (40 km/h in the above example). The direction of the arrow represents the direction of the vector quantity.

1.3 What is the 'resultant' vector?

| The resultant of a number of similar vectors, force vectors, for example, is that single vector which would have the same effect as all the original vectors taken together.

1.4 Describe the graphical addition of vectors.

| The method for finding the resultant of several vectors consists in beginning at any convenient point and drawing (to scale) each vector arrow in turn. They may be taken in any order of succession. The tail end of each arrow is attached to the tip end of the preceding one.

The resultant is represented by an arrow with its tail end at the starting point and its tip end at the tip of the last vector added.

1.5 Describe the parallelogram method of addition of two vectors.

| The resultant of two vectors acting at any angle may be represented by the diagonal of a parallelogram. The two vectors are drawn as the sides of the parallelogram and the resultant is its diagonal, as shown in Fig. 1-1. The direction of the resultant is away from the origin of the two vectors.

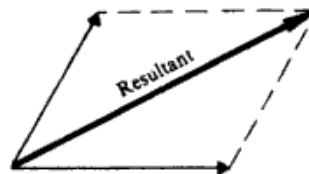

Fig. 1-1

1.6 How do you subtract vectors?

| To subtract a vector **B** from a vector **A**, reverse the direction of **B** and add it vectorially to vector **A**, that is, $\mathbf{A} - \mathbf{B} = \mathbf{A} + (-\mathbf{B})$.

1.7 Describe the trigonometric functions.

| For the right triangle shown in Fig. 1-2, by definition

$$\sin \theta = \frac{o}{h} \quad \cos \theta = \frac{a}{h} \quad \tan \theta = \frac{o}{a}$$

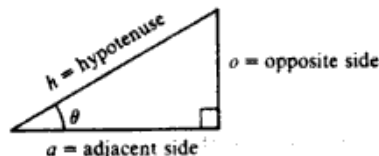

Fig. 1-2

2 □ CHAPTER 1

- 1.8** Express each of the following in scientific notation: (a) 627.4, (b) 0.000365, (c) 20 001, (d) 1.0067, (e) 0.0067.
| (a) 6.274×10^2 . (b) 3.65×10^{-4} . (c) 2.001×10^4 . (d) 1.0067×10^0 . (e) 6.7×10^{-3} .
- 1.9** Express each of the following as simple numbers $\times 10^0$: (a) 31.65×10^{-3} (b) 0.415×10^6 (c) $1/(2.05 \times 10^{-3})$ (d) $1/(43 \times 10^3)$.
| (a) 0.03165. (b) 415,000. (c) 488. (d) 0.0000233.
- 1.10** The diameter of the earth is about 1.27×10^7 m. Find its diameter in (a) millimeters, (b) megameters, (c) miles.
| (a) $(1.27 \times 10^7 \text{ m})(1000 \text{ mm}/1 \text{ m}) = 1.27 \times 10^{10} \text{ mm}$. (b) Multiply meters by $1 \text{ Mm}/10^6 \text{ m}$ to obtain 12.7 Mm. (c) Then use $(1 \text{ km}/1000 \text{ m})(1 \text{ mi}/1.61 \text{ km})$; the diameter is $7.89 \times 10^3 \text{ mi}$.
- 1.11** A 100-m race is run on a 200-m-circumference circular track. The runners run eastward at the start and bend south. What is the displacement of the endpoint of the race from the starting point?
| The runners move as shown in Fig. 1-3. The race is halfway around the track so the displacement is one diameter = $200/\pi = 63.7 \text{ m}$ due south.

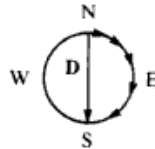

Fig. 1-3

- 1.12** What is a *component* of a vector?

| A component of a vector is its “shadow” (perpendicular drop) on an axis in a given direction. For example, the p -component of a displacement is the distance along the p axis corresponding to the given displacement. It is a scalar quantity, being positive or negative as it is positively or negatively directed along the axis in question. In Fig. 1-4, A_p is positive. (One sometimes defines a vector component as a *vector* pointing along the axis and having the size of the scalar component. If the scalar component is negative the vector component points in the negative direction along the axis.) It is customary, and useful, to resolve a vector into components along *mutually perpendicular* directions (*rectangular components*).

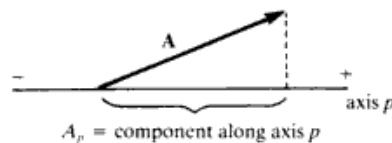

Fig. 1-4

- 1.13** What is the component method for adding vectors?

| Each vector is resolved into its x , y , and z components, with negatively directed components taken as negative. The x component of the resultant, R_x , is the algebraic sum of all the x components. The y and z components of the resultant are found in a similar way.

- 1.14** Define the multiplication of a vector by a scalar.

| The quantity $b\mathbf{F}$ is a vector having magnitude $|b|F$ (the absolute value of b times the magnitude of \mathbf{F}); the direction of $b\mathbf{F}$ is that of \mathbf{F} or $-\mathbf{F}$, depending on whether b is positive or negative.

- 1.15** Using the graphical method, find the resultant of the following two displacements: 2 m at 40° and 4 m at 127° , the angles being taken relative to the $+x$ axis.

| Choose x , y axes as shown in Fig. 1-5 and lay out the displacements to scale tip to tail from the origin. Note that all angles are measured from the $+x$ axis. The resultant vector, \mathbf{R} , points from starting point to endpoint as shown. Measure its length on the scale diagram to find its magnitude, 4.6 m. Using a protractor, measure its angle θ to be 101° . The resultant displacement is therefore 4.6 m at 101° .

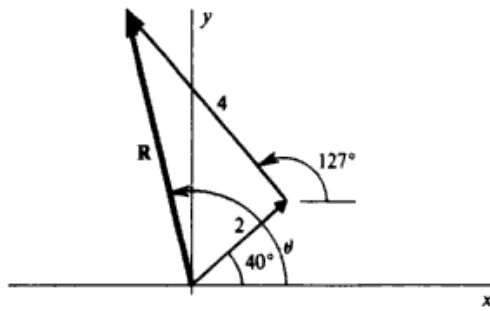

Fig. 1-5

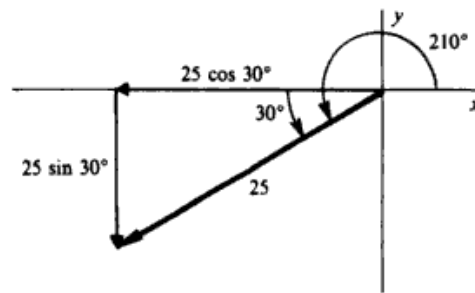

Fig. 1-6

1.16 Find the x and y components of a 25-m displacement at an angle of 210° .

▮ The vector displacement and its components are shown in Fig. 1-6. The components are

$$x \text{ component} = -25 \cos 30^\circ = -21.7 \text{ m} \quad y \text{ component} = -25 \sin 30^\circ = -12.5 \text{ m}$$

Note in particular that each component points in the negative coordinate direction and must therefore be taken as negative.

1.17 Solve Prob. 1.15 by use of rectangular components.

▮ Resolve each vector into rectangular components as shown in Fig. 1-7(a) and (b). (Place a cross-hatch symbol on the original vector to show that it can be replaced by the sum of its vector components.) The resultant has the scalar components

$$R_x = 1.53 - 2.40 = -0.87 \text{ m} \quad R_y = 1.29 + 3.20 = 4.49 \text{ m}$$

Note that components pointing in the negative direction must be assigned a negative value.

The resultant is shown in Fig. 1-7(c); we see that

$$R = \sqrt{(0.87)^2 + (4.49)^2} = 4.57 \text{ m} \quad \tan \phi = \frac{4.49}{0.87}$$

Hence, $\phi = 79^\circ$, from which $\theta = 180^\circ - \phi = 101^\circ$.

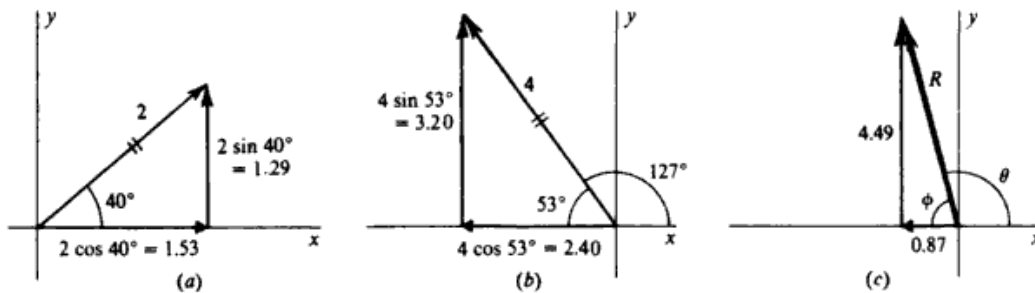

Fig. 1-7

1.18 Add the following two force vectors by use of the parallelogram method: 30 pounds at 30° and 20 pounds at 140° . (A pound of force is chosen such that a 1-kg object weighs 2.21 lb on earth. One pound is equivalent to a force of 4.45 N.)

▮ The force vectors are shown in Fig. 1-8. Construct a parallelogram using them as sides, as shown in Fig. 1-9. The resultant, \mathbf{R} , is then shown as the diagonal. Measurement shows that \mathbf{R} is 30 lb at 72° .

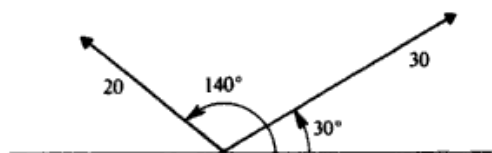

Fig. 1-8

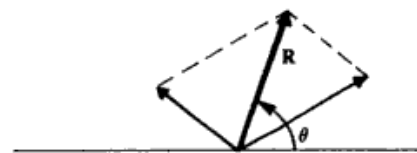
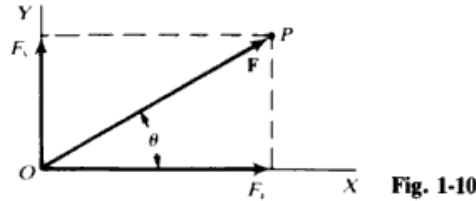

Fig. 1-9

1.19 Find the components of the vector \mathbf{F} in Fig. 1-10 along the x and y axes.

▮ In Fig. 1-10 the dashed perpendiculars from P to X and Y determine the magnitudes and directions of the vector components \mathbf{F}_x and \mathbf{F}_y of vector \mathbf{F} . The *signed* magnitudes of these vector components, which are the scalar components of \mathbf{F} , are written as F_x , F_y . It is seen that $F_x = F \cos \theta$, $F_y = F \sin \theta$.



1.20 (a) Let \mathbf{F} have a magnitude of 300 N and make angle $\theta = 30^\circ$ with the positive x direction. Find F_x and F_y .
 (b) Suppose that $F = 300$ N and $\theta = 145^\circ$ (\mathbf{F} is here in the second quadrant). Find F_x and F_y .

▮ (a) $F_x = 300 \cos 30^\circ = 259.8$ N, $F_y = 300 \sin 30^\circ = 150$ N. (b) $F_x = 300 \cos 145^\circ = (300)(-0.8192) = -245.75$ N (in the negative direction of X). $F_y = 300 \sin 145^\circ = (300)(+0.5736) = 172.07$ N

1.21 A car goes 5.0 km east, 3.0 km south, 2.0 km west, and 1.0 km north. (a) Determine how far north and how far east it has been displaced. (b) Find the displacement vector both graphically and algebraically.

▮ (a) Recalling that vectors can be added in any order we can immediately add the 3.0-km south and 1.0-km north displacement vectors to get a net 2.0-km south displacement vector. Similarly the 5.0-km east and 2.0-km west vectors add to a 3-km east displacement vector. Because the east displacement contributes no component along the north-south line and the south displacement has no component along the east-west line, the car is 2.0 km north and 3.0 km east of its starting point. (b) Using the head-to-tail method, we easily can construct the resultant displacement \mathbf{D} as shown in Fig. 1-11. Algebraically we note that

$$D = \sqrt{D_x^2 + D_y^2} = \sqrt{2^2 + 3^2} = 3.6 \text{ km} \quad \tan \phi = -\frac{2}{3} \quad \text{or} \quad \tan \theta = \frac{2}{3} \quad \theta = 34^\circ \text{ south of east.}$$

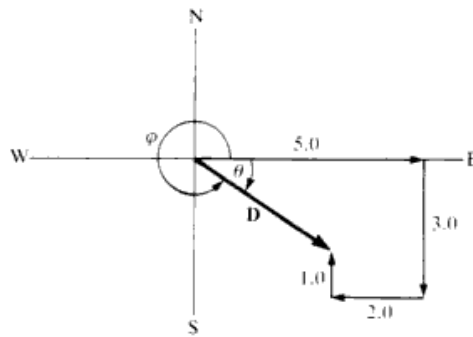

Fig. 1-11

1.22 Find the x and y components of a 400-N force at an angle of 125° to the x axis.

▮ Formal method (uses angle above positive x axis):

$$F_x = (400 \text{ N}) \cos 125^\circ = -229 \text{ N} \quad F_y = (400 \text{ N}) \sin 125^\circ = 327 \text{ N}$$

Visual method (uses only acute angles above or below positive or negative x axis):

$$|F_x| = F \cos \phi = 400 \cos 55^\circ = 229 \text{ N} \quad |F_y| = F \sin \phi = 400 \sin 55^\circ = 327 \text{ N}$$

By inspection of Fig. 1-12, $F_x = -|F_x| = -229$ N; $F_y = |F_y| = 327$ N.

1.23 Add the following two coplanar forces: 30 N at 37° and 50 N at 180° .

▮ Split each into components and find the resultant: $R_x = 24 - 50 = -26$ N, $R_y = 18 + 0 = 18$ N. Then $R = 31.6$ N and $\tan \theta = 18/-26$, so $\theta = 145^\circ$.

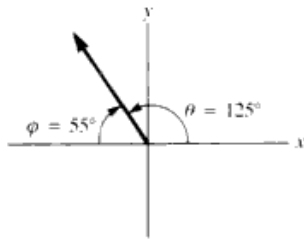

Fig. 1-12

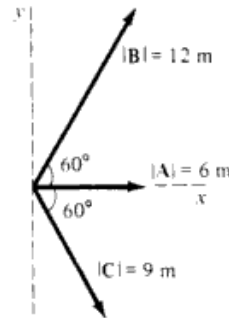

Fig. 1-13

1.24 For the vectors **A** and **B** shown in Fig. 1-13, find (a) **A + B**, (b) **A - B**, and (c) **B - A**.

| The components are $A_x = 6$ m, $A_y = 0$, $B_x = 12 \cos 60^\circ = 6$ m, and $B_y = 12 \sin 60^\circ = 10.4$ m. (a) $(\mathbf{A} + \mathbf{B})_x = 12$ m and $(\mathbf{A} + \mathbf{B})_y = 10.4$ m, so that $\mathbf{A} + \mathbf{B} = 15.9$ m at 40.9° . (b) $(\mathbf{A} - \mathbf{B})_x = 0$ and $(\mathbf{A} - \mathbf{B})_y = 0 - 10.4$ so $\mathbf{A} - \mathbf{B} = 10.4$ m at -90° . (c) $(\mathbf{B} - \mathbf{A})_x = 0$ and $(\mathbf{B} - \mathbf{A})_y = 10.4 - 0$ so $\mathbf{B} - \mathbf{A} = 10.4$ m at 90° .

1.25 For the vectors shown in Fig. 1-13, find (a) **A + B + C** and (b) **A + B - C**.

| The x and y components of **C** are 4.5 m and -7.8 m. (a) The x component is $A_x + B_x + C_x = 16.5$ and for the y component we find 2.6, so the vector is 16.7 m at 9.0° . (b) $A_x + B_x - C_x = 7.5$ and the y component is $0 + 10.4 - (-7.8) = 18.2$; changing this to a magnitude and angle, we find 19.7 m at 68° .

1.26 For the vectors shown in Fig. 1-13, find (a) **A - 2C**, (b) **B - (A + C)**, and (c) **-A - B - C**.

| (a) The x component is $A_x - 2C_x = -3$ and the y component is $-2(-7.8) = 15.6$, giving 15.9 m at 101° . (b) The x component $= 6 - (6 + 4.5) = -4.5$; the y component $= 10.4 - [0 + (-7.8)] = 18.2$; therefore $(4.5^2 + 18.2^2)^{1/2} = 18.7$ m at 104° . (c) This is the negative of the vector of Prob. 1.25 (a), so that it is 16.7 m at $9.0^\circ + 180^\circ = 189^\circ = -171^\circ$.

1.27 A displacement of 20 m is made in the xy plane at an angle of 70° (i.e., 70° counterclockwise from the +x axis). Find its x and y components. Repeat if the angle is 120° ; if the angle is 250° .

| In each case $s_x = s \cos \theta$ and $s_y = s \sin \theta$. The results are 6.8, 18.8 m; -10.0, 17.3 m; -6.8, -18.8 m.

1.28 It is found that an object will hang properly if an x force of 20 N and a y force of -30 N are applied to it. Find the single force (magnitude and direction) which would do the same job.

| Adding components of the forces yields $R_x = 20$ N and $R_y = -30$ N. $R = (400 + 900)^{1/2} = 36$ N. Calling θ the counterclockwise angle from the +x axis, $\tan \theta = -30/20$ and so $\theta = 303.7^\circ = -56.3^\circ$.

1.29 Find the magnitude and direction of the force which has an x component of -40 N and a y component of -60 N.

| The resultant of these two forces is $R = (1600 + 3600)^{1/2} = 72$ N. The angle θ is $180^\circ + \tan^{-1}(6/4) = 236.3^\circ$.

1.30 Find the magnitude and direction of the sum of the following two coplanar displacement vectors: 20 m at 0° and 10 m at 120° .

| Splitting each into components, $R_x = 20 - 5 = 15$ m and $R_y = 0 + 8.7 = 8.7$ m. Then $R = 17.3$ m with $\tan \theta = 8.7/15$ giving $\theta = 30^\circ$.

1.31 Four coplanar forces act on a body at point O as shown in Fig. 1-14(a). Find their resultant graphically.

| Starting from O, the four vectors are plotted in turn as shown in Fig. 1.14(b). Place the tail end of one vector at the tip end of the preceding one. The arrow from O to the tip of the last vector represents the resultant of the vectors.

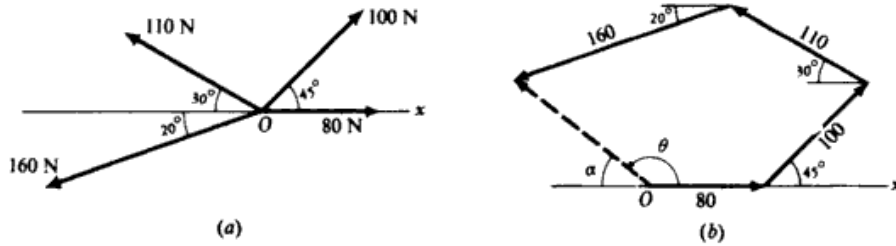

Fig. 1-14

Measure R from the scale drawing in Fig. 1.14(b) and find it to be 119 N. Angle α is measured by protractor and is found to be 37° . Hence the resultant makes an angle $\theta = 180^\circ - 37^\circ = 143^\circ$ with the positive x axis. The resultant is 119 N at 143° .

1.32 Solve Prob. 1.31 by use of the rectangular component method.

▮ The vectors and their components are as follows.

magnitude, N	x component, N	y component, N
80	80	0
100	$100 \cos 45^\circ = 71$	$100 \sin 45^\circ = 71$
110	$-110 \cos 30^\circ = -95$	$110 \sin 30^\circ = 55$
160	$-160 \cos 20^\circ = -150$	$-160 \sin 20^\circ = -55$

Note the sign of each component. To find the resultant, we have

$$R_x = 80 + 71 - 95 - 150 = -94 \text{ N} \quad R_y = 0 + 71 + 55 - 55 = 71 \text{ N}$$

The resultant is shown in Fig. 1-15; we see that $R = \sqrt{(94)^2 + (71)^2} = \underline{118 \text{ N}}$. Further, $\tan \alpha = 71/94$, from which $\alpha = 37^\circ$. Therefore the resultant is 118 N at $180 - 37 = \underline{143^\circ}$.

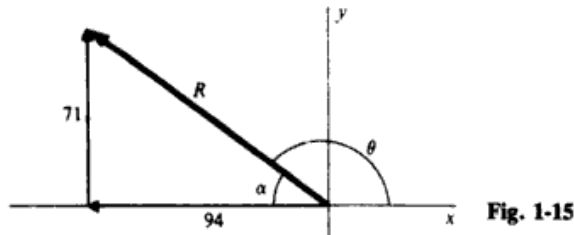

Fig. 1-15

1.33 Perform graphically the following vector additions and subtractions, where A , B , and C are the vectors shown in Fig. 1-16: (a) $A + B$. (b) $A + B + C$. (c) $A - B$. (d) $A + B - C$.

▮ See Fig. 1-16(a) through (d). In (c), $A - B = A + (-B)$; that is, to subtract B from A , reverse the direction of B and add it vectorially to A . Similarly, in (d), $A + B - C = A + B + (-C)$, where $-C$ is equal in magnitude but opposite in direction to C .

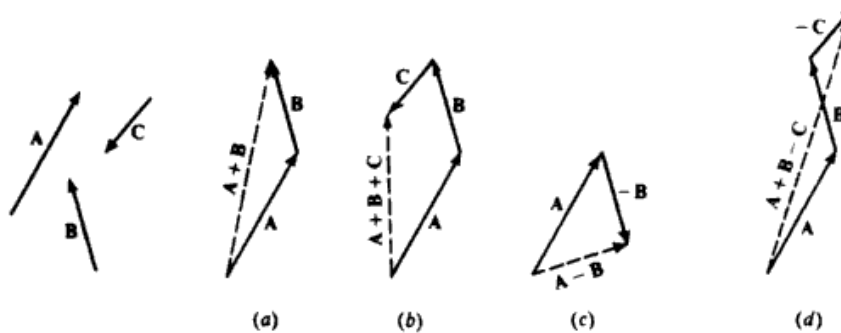

Fig. 1-16

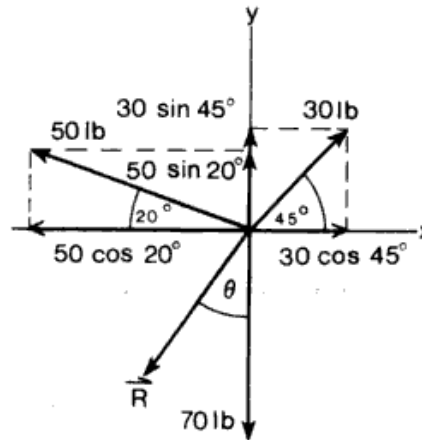

Fig. 1-17

1.34 Find the resultant **R** of the following forces all acting on the same point in the given directions: 30 lb to the northeast; 70 lb to the south; and 50 lb 20° north of west.

▮ Choose east as the positive *x* direction (Figure 1-17).

x components, lb	y components, lb
$30 \cos 45^\circ = 21.2$	$30 \sin 45^\circ = 21.2$
$-50 \cos 20^\circ = -47.0$	$50 \sin 20^\circ = 17.1$
Total = -25.8 lb	$-70 = -70$
	Total = -31.7 lb

$$R = \sqrt{(-25.8)^2 + (-31.7)^2} = \sqrt{665.8 + 1004.9} = 40.9 \text{ lb} \quad \tan \theta = \frac{25.8}{31.7} = 0.8139 \quad \theta = 39^\circ \text{ west of south}$$

1.35 Find the angle between two vector forces of equal magnitude, such that the resultant is one-third as much as either of the original forces.

▮ In the vector force diagram (Fig. 1-18), the diagonals of the rhombus bisect each other. Thus,

$$\cos \theta = \frac{F/6}{F} = \frac{1}{6} = 0.1667 \quad \theta = 80.4^\circ \quad 2\theta = 160.8^\circ$$

The angle between the two forces is 160.8°.

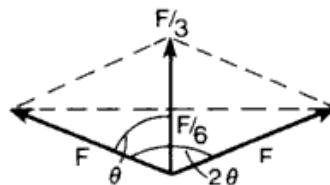

Fig. 1-18

1.36 Find the vector sum of the following four displacements on a map: 60 mm north; 30 mm west; 40 mm at 60° west of north; 50 mm at 30° west of south. Solve (a) graphically and (b) algebraically.

▮ (a) With ruler and protractor, construct the sum of vector displacements by the tail-to-head method as shown in Fig. 1-19. The resultant vector from tail of first to head of last is then also measured with ruler and protractor. *Ans.*: 97 mm at 67.7° W of N. (b) Let **D** = resultant displacement.

$$D_x = -30 - 40 \sin 60^\circ - 50 \sin 30^\circ = -89.6 \text{ mm} \quad D_y = 60 + 40 \cos 60^\circ - 50 \cos 30^\circ = +36.7 \text{ mm}$$

$$D = \sqrt{D_x^2 + D_y^2} = 96.8 \text{ mm} \quad \tan \phi = \left| \frac{D_y}{D_x} \right| \Rightarrow \phi = 22.3^\circ \quad \text{above negative } x \text{ axis}$$

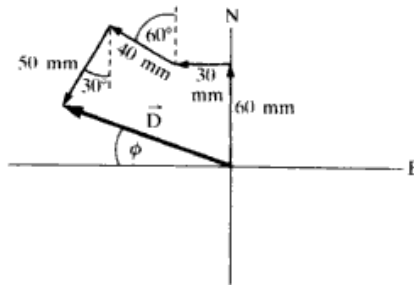

Fig. 1-19

- 1.37 Two forces, 80 N and 100 N acting at an angle of 60° with each other, pull on an object. What single force would replace the two forces? What single force (called the *equilibrant*) would balance the two forces? Solve algebraically.

▮ Choose the x axis along the 80-N force and the y axis so that the 100-N force 60° above the positive x axis has a positive y component. Then the single force \mathbf{R} that replaces the two forces is the vector sum of these forces:

$$R_x = 80 + 100 \cos 60^\circ = 130 \text{ N} \quad R_y = 100 \sin 60^\circ = 87 \text{ N}$$

$$R = \sqrt{R_x^2 + R_y^2} = \underline{156 \text{ N}} \quad \theta = \tan^{-1} \left| \frac{R_y}{R_x} \right| = \underline{34^\circ} \text{ above positive } x \text{ axis.}$$

The force that balances \mathbf{R} is $-\mathbf{R}$ with a magnitude of 156 N but pointing in the opposite direction to \mathbf{R} : 34° below negative x axis (or 214° above positive x axis).

- 1.38 Two forces act on a point object as follows: 100 N at 170° and 100 N at 50° . Find their resultant.

▮ $\mathbf{F}_1 = 100 \text{ N}$ at 170° above x axis; $\mathbf{F}_2 = 100 \text{ N}$ at 50° above x axis.

$$\mathbf{R} = \mathbf{F}_1 + \mathbf{F}_2 \quad R_x = 100 \cos 170^\circ + 100 \cos 50^\circ = -34.2 \text{ N} \quad R_y = 100 \sin 170^\circ + 100 \sin 50^\circ = 94.0 \text{ N}$$

$$R = \sqrt{R_x^2 + R_y^2} = \underline{100 \text{ N}} \quad \theta = \tan^{-1} \frac{R_y}{R_x}$$

has two solutions: 290° and 110° . From a look at its components we see that \mathbf{R} lies in the second quadrant, so the answer is 110° (or 70° above negative x axis). In a less formal approach we can find: $\phi = \tan^{-1} |R_y/R_x|$, which will give an acute angle solution, in this case of 70° , which always represents the angle with the positive or negative x axis, and either above or below that axis. Since we already know from the components which quadrant \mathbf{R} lies in, we know the direction precisely. In our case the 70° is above the negative x axis.

- 1.39 A force of 100 N makes an angle of θ with the x axis and has a y component of 30 N. Find both the x component of the force and the angle θ .

▮ The data are sketched in Fig. 1-20. We wish to find F_x and θ . We know that

$$\sin \theta = \frac{o}{h} = \frac{30}{100} = 0.30$$

from which $\theta = \underline{17.5^\circ}$. Then, since $a = h \cos \theta$, we have

$$F_x = 100 \cos 17.5^\circ = \underline{95.4 \text{ N}}$$

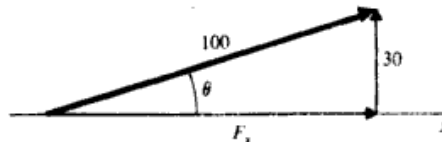

Fig. 1-20

- 1.40 A boat can travel at a speed of 8 km/h in still water on a lake. In the flowing water of a stream, it can move at 8 km/h relative to the water in the stream. If the stream speed is 3 km/h, how fast can the boat move past a tree on the shore in traveling (a) upstream? (b) downstream?

▮ (a) If the water were standing still, the boat's speed past the tree would be 8 km/h. But the stream is carrying it in the opposite direction at 3 km/h. Therefore the boat's speed relative to the tree is $8 - 3 = 5$ km/h. (b) In this case, the stream is carrying the boat in the same direction the boat is trying to move. Hence its speed past the tree is $8 + 3 = 11$ km/h.

- 1.41 A plane is traveling eastward at an airspeed of 500 km/h. But a 90 km/h wind is blowing southward. What are the direction and speed of the plane relative to the ground?

▮ The plane's resultant velocity is the sum of two velocities, 500 km/h eastward and 90 km/h southward. These component velocities are shown in Fig. 1-21. The plane's resultant velocity is found by use of

$$R = \sqrt{(500)^2 + (90)^2} = 508 \text{ km/h}$$

The angle α is given by

$$\tan \alpha = \frac{90}{500} = 0.180$$

from which $\alpha = 10.2^\circ$. The plane's velocity relative to the ground is 508 km/h at 10.2° south of east.

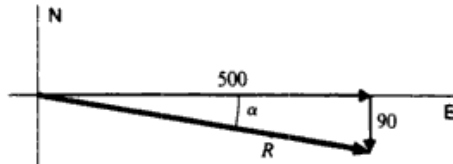

Fig. 1-21

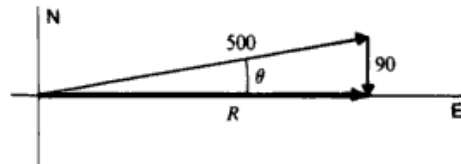

Fig. 1-22

- 1.42 With the same airspeed as in Prob. 1.41, in what direction must the plane head in order to move due east relative to the earth?

▮ The sum of the plane's velocity through the air and the velocity of the wind must be the resultant eastward velocity of the plane relative to the earth. This is shown in the vector diagram of Fig. 1-22. It is seen that $\sin \theta = 90/500$, from which $\theta = 10.4^\circ$. The plane should head 10.4° north of east if it is to move eastward on the earth.

If we wish to find the plane's eastward speed, Fig. 1-22 tells us that $R = 500 \cos \theta = 492$ km/h.

- 1.43 A child pulls a rope attached to a sled with a force of 60 N. The rope makes an angle of 40° to the ground. (a) Compute the effective value of the pull tending to move the sled along the ground. (b) Compute the force tending to lift the sled vertically.

▮ As shown in Fig. 1-23, the components of the 60 N force are 39 N and 46 N. (a) The pull along the ground is the horizontal component, 46 N. (b) The lifting force is the vertical component, 39 N.

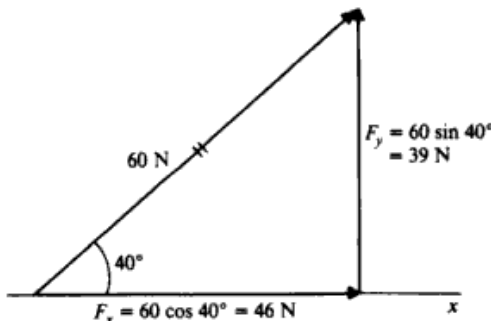

Fig. 1-23

- 1.44 Find the resultant of the coplanar force system shown in Fig. 1-24.

▮ $\mathbf{R} = \mathbf{F}_1 + \mathbf{F}_2 + \mathbf{F}_3$ $R_x = -40 + 80 \cos 30^\circ + 0 = 29.3 \text{ lb}$ $R_y = 0 - 80 \sin 30^\circ + 60 = 20 \text{ lb}$

$$R = \sqrt{R_x^2 + R_y^2} = 35.4 \text{ lb} \quad \theta = \tan^{-1} \frac{R_y}{R_x} = 34.3^\circ \quad \text{above } +x \text{ axis}$$

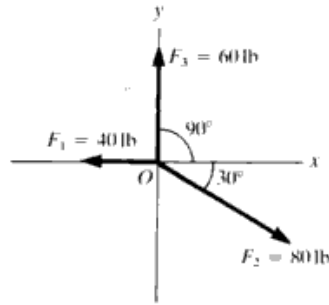

Fig. 1-24

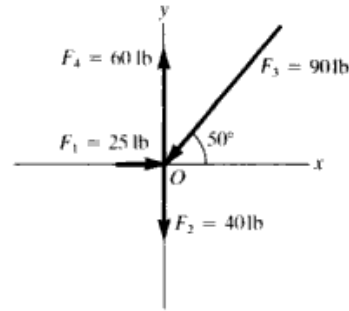

Fig. 1-25

1.45 Repeat Prob. 1.44 for Fig. 1-25.

| $\mathbf{R} = \mathbf{F}_1 + \mathbf{F}_2 + \mathbf{F}_3 + \mathbf{F}_4$ $R_x = 25 + 0 - 90 \cos 50^\circ + 0 = -32.8 \text{ lb}$ $R_y = 0 - 40 - 90 \sin 50^\circ + 60 = -48.9 \text{ lb}$

$$R = \sqrt{R_x^2 + R_y^2} = \underline{58.9 \text{ lb}} \quad \phi = \tan^{-1} \left| \frac{R_y}{R_x} \right| = \underline{56.1^\circ} \quad \text{below } -x \text{ axis}$$

1.46 Repeat Prob. 1.44 for Fig 1-26.

| $\mathbf{R} = \mathbf{R}_1 + \mathbf{R}_2 + \mathbf{R}_3 + \mathbf{R}_4$ $R_x = -125 \cos 25^\circ + 0 + 180 \cos 23^\circ + 150 \cos 62^\circ = 122.8 \text{ lb}$

$$R_y = -125 \sin 25^\circ - 130 - 180 \sin 23^\circ + 150 \sin 62^\circ = -120.7 \text{ lb}$$

$$R = \sqrt{R_x^2 + R_y^2} = \underline{172.2 \text{ lb}}, \quad \phi = \tan^{-1} \left| \frac{R_y}{R_x} \right| = \underline{44.5^\circ} \quad \text{below } +x \text{ axis}$$

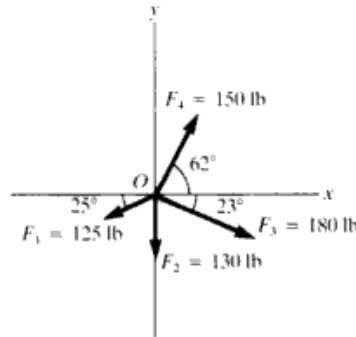

Fig. 1-26

1.47 Compute algebraically the resultant (**R**) and equilibrant (**E**) of the following coplanar forces: 100 kN at 30°, 141.4 kN at 45°, and 100 kN at 240°.

| $\mathbf{R} = \mathbf{F}_1 + \mathbf{F}_2 + \mathbf{F}_3$ $R_x = 100 \cos 30^\circ + 141.4 \cos 45^\circ + 100 \cos 240^\circ = 136.6 \text{ kN}$.

Note: $100 \cos 240^\circ = -100 \cos 60^\circ$ $100 \sin 240^\circ = -100 \sin 60^\circ$.

$$R_y = 100 \sin 30^\circ + 141.4 \sin 45^\circ + 100 \sin 240^\circ = 63.4 \text{ kN}$$

$$R = \sqrt{R_x^2 + R_y^2} = \underline{150.6 \text{ kN}} \quad \phi = \tan^{-1} \frac{R_y}{R_x} = \underline{24.9^\circ} \quad \text{above } +x \text{ axis}.$$

$\mathbf{E} = -\mathbf{R} = \underline{150.6 \text{ kN}}$ at $24.9^\circ + 180^\circ = \underline{204.9^\circ}$ above $+x$ axis

1.48 Compute algebraically the resultant of the following displacements: 20 m at 30°, 40 m at 120°, 25 m at 180°, 42 m at 270°, and 12 m at 315°.

| $\mathbf{D} = \mathbf{d}_1 + \mathbf{d}_2 + \mathbf{d}_3 + \mathbf{d}_4 + \mathbf{d}_5 = \text{resultant displacement}$ $D_x = 20 \cos 30^\circ + 40 \cos 120^\circ - 25 + 0 + 12 \cos 315^\circ = -19.3 \text{ m}$

Note: 180° is along $-x$ axis; 270° is along $-y$ axis; $\cos 120^\circ = -\cos 60^\circ$; $\sin 120^\circ = \sin 60^\circ$; $\cos 315^\circ = \cos 45^\circ$; $\sin 315^\circ = -\sin 45^\circ$.

$$D_y = 20 \sin 30^\circ + 40 \sin 120^\circ + 0 - 42 + 12 \sin 315^\circ = -5.8 \text{ m}$$

$$D_y = \sqrt{D_x^2 + D_y^2} = 20.2 \text{ m} \quad \phi = \tan^{-1} \left| \frac{D_y}{D_x} \right| = 16.7^\circ \quad \text{below } -x \text{ axis}$$

or $\theta = \tan^{-1} \frac{D_y}{D_x} = 196.7^\circ$ above $+x$ axis.

1.49 Refer to Fig. 1-27. In terms of vectors **A** and **B**, express the vectors **P**, **R**, **S**, and **Q**.

▮ We have here a parallelogram, so $\mathbf{R} = \mathbf{B}$ and $\mathbf{P} = \mathbf{A} + \mathbf{R} = \mathbf{A} + \mathbf{B}$. Clearly $\mathbf{S} = -\mathbf{A}$ and \mathbf{Q} is the sum of $-\mathbf{B}$ with \mathbf{A} or $\mathbf{Q} = \mathbf{A} - \mathbf{B}$.

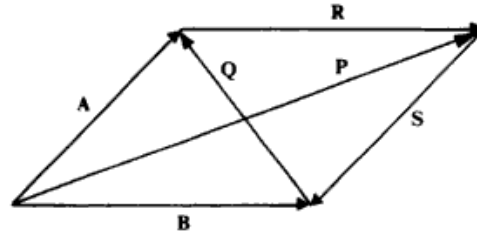

Fig. 1-27

1.50 Refer to Fig. 1-28. In terms of vectors **A** and **B**, express the vectors **E**, **D - C**, and **E + D - C**.

▮ Clearly $-\mathbf{E} = \mathbf{A} + \mathbf{B}$ or $\mathbf{E} = -(\mathbf{A} + \mathbf{B}) = -\mathbf{A} - \mathbf{B}$. $\mathbf{D} - \mathbf{C} = \mathbf{D} + (-\mathbf{C}) = \mathbf{A}$. Then $\mathbf{E} + \mathbf{D} - \mathbf{C} = \mathbf{E} + \mathbf{A} = -\mathbf{B}$.

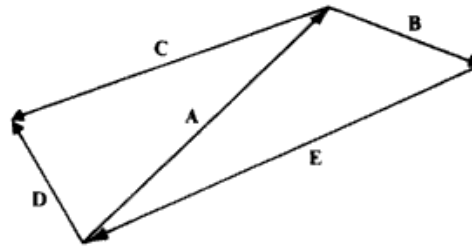

Fig. 1-28

1.51 A displacement **D** of 100 m from the origin at an angle of 37° above the x axis is the result of three successive displacements: \mathbf{d}_1 , which is 100 m along the negative x axis; \mathbf{d}_2 , which is 200 m at an angle of 150° above the x axis; and a displacement \mathbf{d}_3 . Find \mathbf{d}_3 .

▮ $\mathbf{D} = \mathbf{d}_1 + \mathbf{d}_2 + \mathbf{d}_3$ $D_x = d_{1x} + d_{2x} + d_{3x}$ or $100 \cos 37^\circ = -100 + 200 \cos 150^\circ + d_{3x}$ $d_{3x} = 353 \text{ m}$
 (Note: $\cos 150^\circ = -\cos 30^\circ$) $D_y = d_{1y} + d_{2y} + d_{3y}$ or $100 \sin 37^\circ = 0 + 200 \sin 150^\circ + d_{3y}$
 $d_{3y} = -40 \text{ m}$ (Note: $\sin 150^\circ = \sin 30^\circ$). $d_3 = \sqrt{d_{3x}^2 + d_{3y}^2} = 355 \text{ m}$ $\phi = \tan^{-1} \left| \frac{d_{3y}}{d_{3x}} \right| = 6.5^\circ$ below $+x$ axis

1.52 The resultant force due to the action of four forces is **R**, which is 100 N along the negative y axis. Three of the forces are 100 N, 60° above the x axis; 200 N, 140° above the x axis; 250 N, 320° above the x axis. Find the fourth force.

▮ $\mathbf{R} = \mathbf{F}_1 + \mathbf{F}_2 + \mathbf{F}_3 + \mathbf{F}_4$ $R_x = F_{1x} + F_{2x} + F_{3x} + F_{4x}$ or $0 = 100 \cos 60^\circ + 200 \cos 140^\circ + 250 \cos 320^\circ + F_{4x}$.
 $F_{4x} = -88.3 \text{ N}$ $R_y = F_{1y} + F_{2y} + F_{3y} + F_{4y}$ or $-100 = 100 \sin 60^\circ + 200 \sin 140^\circ + 250 \sin 320^\circ + F_{4y}$.
 $F_{4y} = -154.5 \text{ N}$ $F_4 = \sqrt{F_{4x}^2 + F_{4y}^2} = 180 \text{ N}$ $\phi = \tan^{-1} \left| \frac{F_{4y}}{F_{4x}} \right| = 60^\circ$ below $-x$ axis

1.53 A car whose weight is w is on a ramp which makes an angle θ to the horizontal. How large a perpendicular force must the ramp withstand if it is not to break under the car's weight?

▮ As shown in Fig. 1-29, the car's weight is a force \mathbf{w} that pulls straight down on the car. We take components of \mathbf{w} along the incline and perpendicular to it. The ramp must balance the force component $w \cos \theta$ if the car is not to crash through the ramp.

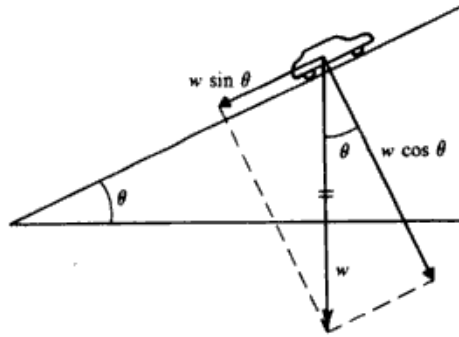

Fig. 1-29

1.54 The five coplanar forces shown in Fig. 1-30(a) act on an object. Find the resultant force due to them.

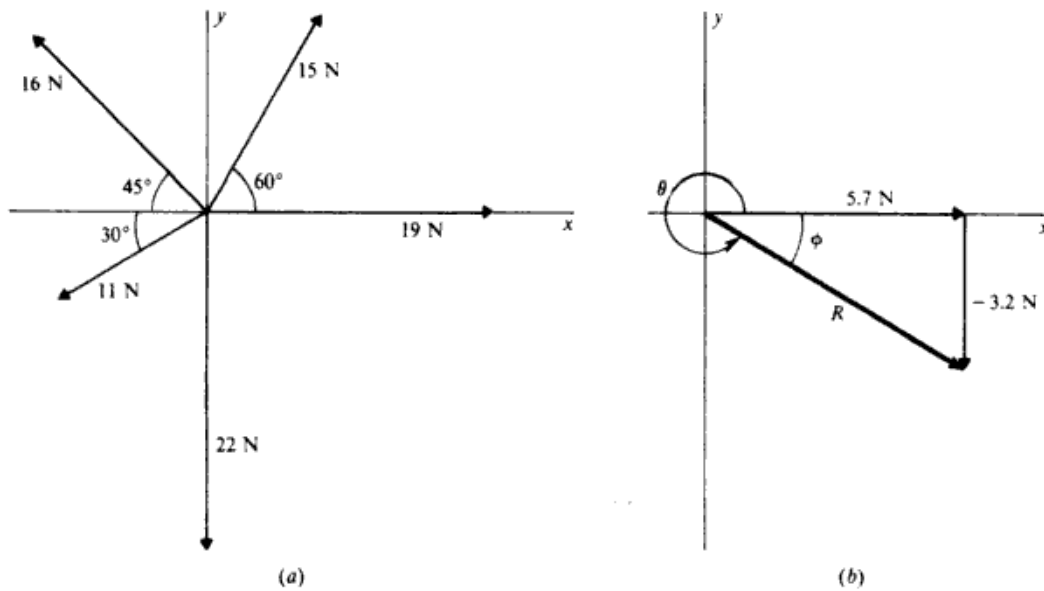

Fig. 1-30

▮ (1) Find the x - and y -components of each force.

magnitude, N	x component, N	y component, N
19	19.0	0
15	$15 \cos 60^\circ = 7.5$	$15 \sin 60^\circ = 13.0$
16	$-16 \cos 45^\circ = -11.3$	$16 \sin 45^\circ = 11.3$
11	$-11 \cos 30^\circ = -9.5$	$-11 \sin 30^\circ = -5.5$
22	0	-22.0

Note the signs to indicate + and - directions.

(2) The resultant \mathbf{R} has components

$$R_x = \sum F_x = 19.0 + 7.5 - 11.3 - 9.5 + 0 = +5.7 \text{ N} \quad R_y = \sum F_y = 0 + 13.0 + 11.3 - 5.5 - 22.0 = -3.2 \text{ N}$$

(3) Find the magnitude of the resultant from

$$R = \sqrt{R_x^2 + R_y^2} = 6.5 \text{ N}$$

(4) Sketch the resultant as shown in Fig. 1-29(b) and find its angle. We see that

$$\tan \phi = \frac{3.2}{5.7} = 0.56$$

from which $\phi = 29^\circ$. Then we have $\theta = 360^\circ - 29^\circ = 331^\circ$. The resultant is 6.5 N at 331° (or -29°).

- 1.55** Find algebraically the resultant (**R**) and equilibrant (**E**) of the following coplanar forces: 300 N at 0°, 400 N at 30°, and 400 N at 150°.

| $R = F_1 + F_2 + F_3$ $E = -R$ $R_x = 300 + 400 \cos 30^\circ + 400 \cos 150^\circ = 300$
 Note that $400 \cos 150^\circ = -400 \cos 30^\circ$ $400 \sin 150^\circ = 400 \sin 30^\circ$

$R_y = 0 + 400 \sin 30^\circ + 400 \sin 150^\circ = 400$ N $R = \sqrt{R_x^2 + R_y^2} = 500$ N $\phi = \tan^{-1} \left| \frac{R_y}{R_x} \right| = 53^\circ$ above +x axis.

Then $E = 500$ N, $\phi_E = 53^\circ$ below -x axis.

1.2 THREE-DIMENSIONAL VECTORS; DOT AND CROSS PRODUCTS

- 1.56** Find the magnitude of the vector **A** in Fig. 1-31, whose tail lies at the origin and whose head lies at the point (7.0 m, 4.0 m, 5.0 m).

| First, note that the vector **A** and its vector component A_z are the hypotenuse and one side of a right triangle whose plane is perpendicular to the xy plane. Hence the pythagorean theorem gives $A^2 = B^2 + A_z^2$. But the vector **B** is itself the hypotenuse of the right triangle in the xy plane whose sides are the vector components A_x and A_y . Thus you can use the pythagorean theorem again to obtain $B^2 = A_x^2 + A_y^2$. Combining the two equations,

$$A^2 = A_x^2 + A_y^2 + A_z^2 \quad \text{or} \quad A = \sqrt{A_x^2 + A_y^2 + A_z^2}$$

which is the form taken by the pythagorean theorem in three dimensions.

For the data,

$$A = \sqrt{(7.0 \text{ m})^2 + (4.0 \text{ m})^2 + (5.0 \text{ m})^2} = 9.5 \text{ m}$$

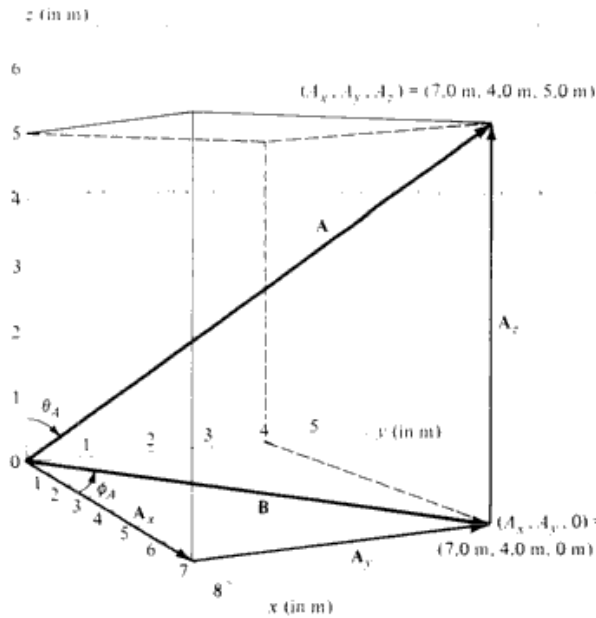

Fig. 1-31

- 1.57** Find the scalar components of the three-dimensional vector **F** in Fig. 1-32.

| In Fig. 1-32, F_x, F_y, F_z are the rectangular vector components of **F**; the scalar components F_x, F_y, F_z are given by

$$F_x = F \cos \theta_1 \quad F_y = F \cos \theta_2 \quad F_z = F \cos \theta_3$$

Or for convenience, writing $\cos \theta_1 = l, \cos \theta_2 = m, \cos \theta_3 = n,$

$$F_x = Fl \quad F_y = Fm \quad F_z = Fn$$

$l, m,$ and n are referred to as the *direction cosines* of **F**. By the three-dimensional pythagorean theorem (Prob. 1.56), $l^2 + m^2 + n^2 = 1.$

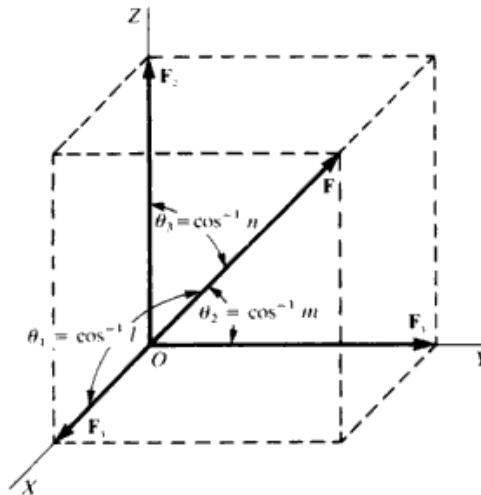

Fig. 1-32

1.58 In Fig. 1-32, let \mathbf{F} represent a force of 200 N. Let $\theta_1 = 60^\circ$, $\theta_2 = 40^\circ$. Find F_x , F_y , and F_z .

▮ $l = 0.5 \quad m = 0.766 \quad n = (1 - l^2 - m^2)^{1/2} = 0.404$

(assuming that F_z is positive; otherwise, $n = -0.404$), and the rectangular components of \mathbf{F} are

$F_x = (200)(0.5) = 100 \text{ N} \quad F_y = 153.2 \text{ N} \quad F_z = 80.8 \text{ N}$

As a check, $(100^2 + 153.2^2 + 80.8^2)^{1/2} \approx 200$. Note that $\theta_3 = 66.17^\circ$.

1.59 Find the vector sum (\mathbf{R}) of three vectors, \mathbf{F}_1 , \mathbf{F}_2 , \mathbf{F}_3 , drawn from the origin of a three-dimensional coordinate system such as that of Fig. 1.32.

▮ Following the component method,

$R_x = F_{1x} + F_{2x} + F_{3x} \quad R_y = F_{1y} + F_{2y} + F_{3y} \quad R_z = F_{1z} + F_{2z} + F_{3z}$

and

$R = [(F_{1x} + F_{2x} + F_{3x})^2 + (F_{1y} + F_{2y} + F_{3y})^2 + (F_{1z} + F_{2z} + F_{3z})^2]^{1/2}$

where F_{1x} is the X component of \mathbf{F}_1 , etc. The direction cosines of \mathbf{R} are given by

$l = \frac{F_{1x} + F_{2x} + F_{3x}}{R} \quad m = \frac{F_{1y} + F_{2y} + F_{3y}}{R} \quad n = \frac{F_{1z} + F_{2z} + F_{3z}}{R}$

The resultant (magnitude and direction) of any number of vectors drawn from O can be obtained in the same way.

1.60 Define a unit vector.

▮ Any nonzero vector \mathbf{F} may be written as $\mathbf{F} = F\mathbf{e}$, where F is the magnitude of \mathbf{F} and where \mathbf{e} is a *unit vector* (a vector whose magnitude is 1) in the direction of \mathbf{F} . That is, the magnitude of \mathbf{F} is indicated by F and its direction is that of \mathbf{e} . If \mathbf{F} carries units (e.g., N, m/s), F carries the same units; \mathbf{e} is a dimensionless vector.

1.61 Express the vector \mathbf{F} in Fig. 1.32 in terms of unit vectors along the coordinate axes.

▮ In Fig. 1-32, let us introduce unit vectors \mathbf{i} , \mathbf{j} , \mathbf{k} along X , Y , Z , respectively. Then the vector components of \mathbf{F} can be written as

$\mathbf{F}_x = F_x\mathbf{i} \quad \mathbf{F}_y = F_y\mathbf{j} \quad \mathbf{F}_z = F_z\mathbf{k}$

according to Prob. 1.60. [If one of the scalar components is negative—say, $F_x = -|F_x| = -|F_x|\mathbf{i}$ —then we have $\mathbf{F}_x = -|F_x|\mathbf{i} = |F_x|(-\mathbf{i})$, which is still as prescribed by Prob. 1.60.] Since \mathbf{F} is the resultant of its vector components, we obtain the very important expression $\mathbf{F} = F_x\mathbf{i} + F_y\mathbf{j} + F_z\mathbf{k}$. In this expression, $F_x = F \cos \theta_1 = Fl$, etc., as previously shown; and, as before, the magnitude and direction (direction cosines, that is) are obtained as

$F = (F_x^2 + F_y^2 + F_z^2)^{1/2} \quad l = \frac{F_x}{F} \quad m = \frac{F_y}{F} \quad n = \frac{F_z}{F}$

- 1.62** A force \mathbf{F} has components $F_x = 100$ N, $F_y = 153.2$ N, $F_z = 80.8$ N. Express \mathbf{F} in terms of unit vectors and find its magnitude and direction.

| The vector \mathbf{F} can be written as $\mathbf{F} = 100\mathbf{i} + 153.2\mathbf{j} + 80.8\mathbf{k}$ with magnitude $F = (100^2 + 153.2^2 + 81^2)^{1/2} = 200$ N and direction:

$$l = \frac{100}{200} = 0.5 \quad m = 0.766 \quad n = 0.404$$

Strictly, we should have written

$$\mathbf{F} = (100 \text{ N})\mathbf{i} + (153.2 \text{ N})\mathbf{j} + (80.8 \text{ N})\mathbf{k} \quad \text{or} \quad \mathbf{F} = 100\mathbf{i} + 153.2\mathbf{j} + 80.8\mathbf{k} \text{ N}$$

- 1.63** A force \mathbf{A} is added to a second force which has x and y components 3 N and -5 N. The resultant of the two forces is in the $-x$ direction and has a magnitude of 4 N. Find the x and y components of \mathbf{A} .

| Let $\mathbf{A} = A_x\mathbf{i} + A_y\mathbf{j}$. Then $A_x + 3 = -4$ and $A_y - 5 = 0$. So $A_x = -7$ N and $A_y = 5$ N.

- 1.64** Express \mathbf{A} , \mathbf{B} , and \mathbf{C} of Fig. 1-13 in terms of the unit vectors \mathbf{i} , \mathbf{j} , and \mathbf{k} .

| $\mathbf{A} = A_x\mathbf{i} + A_y\mathbf{j} + A_z\mathbf{k} = 6\mathbf{i} \text{ m}$, $\mathbf{B} = 6\mathbf{i} + 10.4\mathbf{j} \text{ m}$, and $\mathbf{C} = 4.5\mathbf{i} - 7.8\mathbf{j} \text{ m}$.

- 1.65** Find the components of a displacement which when added to a displacement of $7\mathbf{i} - 4\mathbf{j} \text{ m}$ will give a resultant displacement of $5\mathbf{i} - 3\mathbf{j} \text{ m}$.

| We have $A_x + 7 = 5$ and $A_y - 4 = -3$, so $A_x = -2 \text{ m}$ and $A_y = 1 \text{ m}$.

- 1.66** Find the magnitude and direction of the vector sum of the following three vectors: $2\mathbf{i} - 3\mathbf{j}$, $-9\mathbf{i} - 5\mathbf{j}$, $4\mathbf{i} + 8\mathbf{j}$.

| We have $(2 - 9 + 4)\mathbf{i} + (-3 - 5 + 8)\mathbf{j} = -3\mathbf{i}$. Thus, it is 3 units along the $-x$ direction.

- 1.67** What must be the components of a vector which when added to the following two vectors gives rise to a vector $6\mathbf{j}$: $10\mathbf{i} - 7\mathbf{j}$ and $4\mathbf{i} + 2\mathbf{j}$?

| Call the vector \mathbf{A} . Then $A_x + 10 + 4 = 0$ and $A_y - 7 + 2 = 6$. So $A_x = -14$ and $A_y = 11$.

- 1.68** A certain room has a floor which is $5 \times 6 \text{ m}$ and the ceiling height is 3 m. Write an expression for the vector distance from one corner of the room to the corner diagonally opposite it. What is the magnitude of the distance?

| The x , y , z displacements in going from one corner to the other are 5, 6, and 3 m, respectively. Therefore, $\mathbf{D} = 5\mathbf{i} + 6\mathbf{j} + 3\mathbf{k} \text{ m}$. Also, $D^2 = D_x^2 + D_y^2 + D_z^2$, which gives $D = 8.4 \text{ m}$.

- 1.69** Find the displacement vector from the point $(0, 3, -1) \text{ m}$ to the point $(-2, 6, 4) \text{ m}$. Give your answer in \mathbf{i} , \mathbf{j} , \mathbf{k} notation. Also give the magnitude of the displacement.

| The component displacements are $D_x = -2 - 0 = -2$, $D_y = 6 - 3 = 3$, and $D_z = 4 - (-1) = 5$; thus $\mathbf{D} = -2\mathbf{i} + 3\mathbf{j} + 5\mathbf{k} \text{ m}$ and $D = 6.2 \text{ m}$.

- 1.70** An object, originally at the point $(2, 5, 1) \text{ cm}$, is given a displacement $8\mathbf{i} - 2\mathbf{j} + \mathbf{k} \text{ cm}$. Find the coordinates of its new position.

| The new coordinates are $x = 2 + 8 = 10$; $y = 5 + (-2) = 3$; $z = 1 + 1 = 2$. The object is at $(10, 3, 2) \text{ cm}$.

- 1.71** Find the resultant displacement caused by the following three displacements: $2\mathbf{i} - 3\mathbf{k}$, $5\mathbf{j} - 2\mathbf{k}$, and $-6\mathbf{i} + \mathbf{j} + 8\mathbf{k}$, all in millimeters. Give its magnitude as well as its \mathbf{i} , \mathbf{j} , \mathbf{k} representation.

| $\mathbf{R} = (2 - 6)\mathbf{i} + (5 + 1)\mathbf{j} + (-3 - 2 + 8)\mathbf{k} = -4\mathbf{i} + 6\mathbf{j} + 3\mathbf{k} \text{ mm}$, and so $R = 61^{1/2} = 7.8 \text{ mm}$.

- 1.72** Give the \mathbf{i} , \mathbf{j} , \mathbf{k} representation and magnitude of the force which must be added to the following two forces to give a force $7\mathbf{i} - 6\mathbf{j} - \mathbf{k}$: $2\mathbf{i} - 7\mathbf{k}$ and $3\mathbf{j} + 2\mathbf{k}$. All forces are in newtons.

| Call the force \mathbf{F} . Then $F_x + 2 = 7$; $F_y + 3 = -6$; $F_z - 7 + 2 = -1$. Therefore $\mathbf{F} = 5\mathbf{i} - 9\mathbf{j} + 4\mathbf{k} \text{ N}$ and $F = 11 \text{ N}$.

- 1.73** Vectors \mathbf{A} and \mathbf{B} are in the xy plane. If \mathbf{A} is 70 N at 90° and \mathbf{B} is 120 N at 210° , find (a) $\mathbf{A} - \mathbf{B}$, and (b) vector \mathbf{C} such that $\mathbf{A} - \mathbf{B} + \mathbf{C} = 0$.

| **A** and **B** written in terms of unit vectors are $\mathbf{A} = 70\mathbf{j}$ and $\mathbf{B} = -120 \cos 30^\circ \mathbf{i} - 120 \sin 30^\circ \mathbf{j} = -104\mathbf{i} - 60\mathbf{j}$.
(a) $\mathbf{A} - \mathbf{B} = (0 + 104)\mathbf{i} + (70 + 60)\mathbf{j} = 166 \text{ N at } 51^\circ$. **(b)** $\mathbf{C} = -(\mathbf{A} - \mathbf{B}) = -104\mathbf{i} - 130\mathbf{j} = 166 \text{ N at } 231^\circ$.

1.74 If $\mathbf{A} = 2\mathbf{i} - 3\mathbf{j} + 5\mathbf{k}$ mm and $\mathbf{B} = -\mathbf{i} - 2\mathbf{j} + 7\mathbf{k}$ mm, find (in component form) **(a)** $\mathbf{A} - \mathbf{B}$. **(b)** $\mathbf{B} - \mathbf{A}$.
(c) Vector **C** such that $\mathbf{A} + \mathbf{B} + \mathbf{C} = 0$.

| **(a)** $\mathbf{A} - \mathbf{B} = [2 - (-1)]\mathbf{i} + [-3 - (-2)]\mathbf{j} + (5 - 7)\mathbf{k} = 3\mathbf{i} - \mathbf{j} - 2\mathbf{k}$ mm **(b)** $\mathbf{B} - \mathbf{A} = -(\mathbf{A} - \mathbf{B}) = -3\mathbf{i} + \mathbf{j} + 2\mathbf{k}$ mm **(c)** $\mathbf{C} = -(\mathbf{A} + \mathbf{B}) = -\mathbf{i} + 5\mathbf{j} - 12\mathbf{k}$ mm.

1.75 Vector $\mathbf{A} = 3\mathbf{i} + 5\mathbf{j} - 2\mathbf{k}$ and vector $\mathbf{B} = -3\mathbf{j} + 6\mathbf{k}$. Find a vector **C** such that $2\mathbf{A} + 7\mathbf{B} + 4\mathbf{C} = 0$.

| A vector is zero if and only if each of its components is zero. For example, $2A_x + 7B_x + 4C_x = 0$, so $C_x = -1.5$. For C_y , solve $2(5) + 7(-3) + 4C_y = 0$ to obtain $C_y = 2.75$. Similarly, $C_z = -9.5$. Therefore $\mathbf{C} = -1.5\mathbf{i} + 2.75\mathbf{j} - 9.5\mathbf{k}$.

1.76 A certain vector is given by $3\mathbf{i} + 4\mathbf{j} + 7\mathbf{k}$. Find the angle it makes with the z axis.

| First find the projection of the vector in the xy plane; this is $(3^2 + 4^2)^{1/2} = 5$. The magnitude of the vector is $(7^2 + 5^2)^{1/2} = 8.6$ and it makes an angle of $\tan^{-1}(5/7) = 35.5^\circ$ to the z axis. Otherwise, from Prob. 1.61,

$$\cos \theta_3 = \frac{7}{\sqrt{3^2 + 4^2 + 7^2}} = 0.814 \quad \theta_3 = 35.5^\circ$$

1.77 What must be the relation between vectors **A** and **B** if the following condition is to be true:

$$\mathbf{A} - 2\mathbf{B} = -3(\mathbf{A} + \mathbf{B})$$

If vector $\mathbf{A} = 6\mathbf{i} - 2\mathbf{k}$ m, what is **B**?

| One has $\mathbf{A} - 2\mathbf{B} = -3\mathbf{A} - 3\mathbf{B}$, so $4\mathbf{A} = -\mathbf{B}$. Substituting $6\mathbf{i} - 2\mathbf{k}$ for **A** gives $\mathbf{B} = -24\mathbf{i} + 8\mathbf{k}$ m.

1.78 What must be the relation between two vectors **A** and **B** if the magnitude of $\mathbf{A} + \mathbf{B}$ equals the magnitude of $\mathbf{A} - \mathbf{B}$, that is,

$$|\mathbf{A} + \mathbf{B}| = |\mathbf{A} - \mathbf{B}|$$

| **A** and **B** must be mutually perpendicular. To see that, let **P** and **Q** be two vectors of the same magnitude. As shown in Fig. 1-33, **P** and **Q** form a rhombus whose diagonals, $\mathbf{P} + \mathbf{Q}$ and $\mathbf{P} - \mathbf{Q}$, are necessarily perpendicular. Now set $\mathbf{P} = \frac{1}{2}(\mathbf{A} + \mathbf{B})$, $\mathbf{Q} = \frac{1}{2}(\mathbf{A} - \mathbf{B})$.

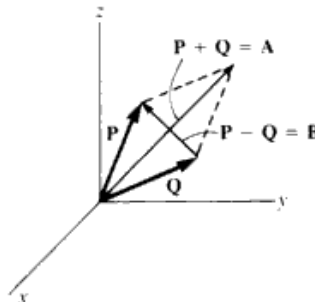

Fig. 1-33

1.79 The vector displacements of two points *A* and *B* from the origin are

$$s_A = 3\mathbf{i} - 2\mathbf{j} + 5\mathbf{k} \text{ cm} \quad \text{and} \quad s_B = -\mathbf{i} - 5\mathbf{j} + 2\mathbf{k} \text{ cm}$$

Find the magnitude and **i**, **j**, **k** representation of the vector from point *A* to point *B*.

| The vector in question has components $D_x = -1 - 3 = -4$; $D_y = -5 - (-2) = -3$; $D_z = 2 - 5 = -3$. Thus $\mathbf{D} = -4\mathbf{i} - 3\mathbf{j} - 3\mathbf{k}$ cm and from $D^2 = 4^2 + 3^2 + 3^2$, we find $D = 5.8$ cm.

1.80 The rectangular components of an acceleration vector **a** are $a_x = 6$, $a_y = 4$, $a_z = 9 \text{ m/s}^2$. Find the vector expression for **a** and its direction cosines.

▮ In vector form, $\mathbf{a} = 6\mathbf{i} + 4\mathbf{j} + 9\mathbf{k} \text{ m/s}^2$. The magnitude of \mathbf{a} is $a = (6^2 + 4^2 + 9^2)^{1/2} = 11.53 \text{ m/s}^2$, and the direction cosines of \mathbf{a} are

$$l = \frac{6}{11.53} \quad m = \frac{4}{11.53} \quad n = \frac{9}{11.53}$$

1.81 Find a vector expression for a line segment.

▮ The straight line ab , Fig. 1-34, is determined by points P_1 and P_2 . Regarding the line segment from P_1 to P_2 as a vector \mathbf{s} , we can write

$$\mathbf{s} = (x_2 - x_1)\mathbf{i} + (y_2 - y_1)\mathbf{j} + (z_2 - z_1)\mathbf{k}$$

with magnitude $s = [(x_2 - x_1)^2 + (y_2 - y_1)^2 + (z_2 - z_1)^2]^{1/2}$ and direction

$$l = \frac{x_2 - x_1}{s} \quad m = \frac{y_2 - y_1}{s} \quad n = \frac{z_2 - z_1}{s}$$

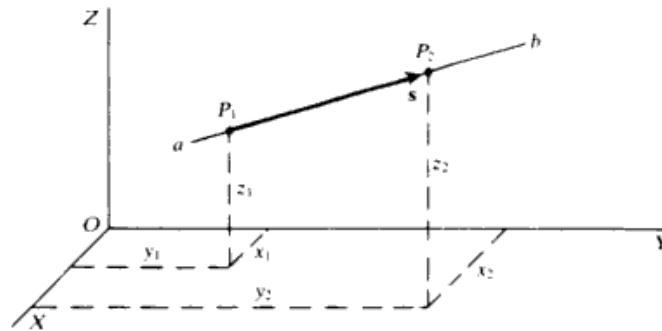

Fig. 1-34

An important special case of this is the so-called radius vector \mathbf{r} , the directed segment from the origin O to a point $P(x, y, z)$:

$$\mathbf{r} = x\mathbf{i} + y\mathbf{j} + z\mathbf{k}$$

with $r = (x^2 + y^2 + z^2)^{1/2}$ and

$$l = \frac{x}{r} \quad m = \frac{y}{r} \quad n = \frac{z}{r}$$

1.82 Consider the velocity vector $\mathbf{v} = 16\mathbf{i} + 30\mathbf{j} + 24\mathbf{k} \text{ m/s}$, with $v = (16^2 + 30^2 + 24^2)^{1/2} = 41.62 \text{ m/s}$, direction given by $l = 16/41.62$, etc.

Now let us multiply \mathbf{v} by 10: $10\mathbf{v} = 160\mathbf{i} + 300\mathbf{j} + 240\mathbf{k} = \mathbf{v}_1$. Find the magnitude and direction of \mathbf{v}_1 .

▮ $v_1 = [(160)^2 + (300)^2 + (240)^2]^{1/2} = (10)(41.62) = 10v$

and the direction cosines of \mathbf{v}_1 are

$$l_1 = \frac{160}{(10)(41.62)} = \frac{16}{41.62} = l \quad m_1 = m \quad n_1 = n$$

which shows that \mathbf{v}_1 has the direction of \mathbf{v} .

1.83 Define the scalar or dot product of two vectors.

▮ The *dot product* of any two vectors, as \mathbf{F}_1 and \mathbf{F}_2 , Fig. 1-35, is written as $\mathbf{F}_1 \cdot \mathbf{F}_2$ and is defined as the product of their magnitudes and the cosine of the included angle. That is, $\mathbf{F}_1 \cdot \mathbf{F}_2 = F_1 F_2 \cos \theta$, which is a scalar quantity. In Fig. 1-35, $F_1 = 75$, $F_2 = 100$, $\theta = 60^\circ$. Thus, $\mathbf{F}_1 \cdot \mathbf{F}_2 = (75)(100)(0.5) = 3750$.

1.84 Find the dot products of the unit vectors along X , Y , Z .

▮ Since \mathbf{i} , \mathbf{j} , \mathbf{k} are mutually perpendicular and of unit magnitude, the definition of the dot product gives

$$\mathbf{i} \cdot \mathbf{i} = \mathbf{j} \cdot \mathbf{j} = \mathbf{k} \cdot \mathbf{k} = 1 \quad \mathbf{i} \cdot \mathbf{j} = \mathbf{i} \cdot \mathbf{k} = \mathbf{j} \cdot \mathbf{k} = 0$$

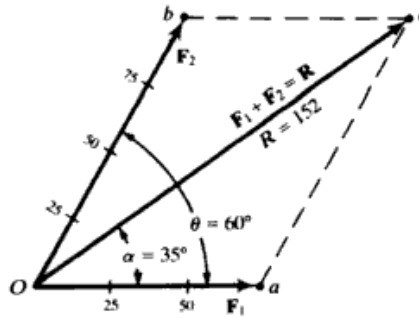

Fig. 1-35

1.85 Find the dot product of any two vectors in terms of rectangular components.

▮ Write any two vectors as

$$\mathbf{F}_1 = F_{1x}\mathbf{i} + F_{1y}\mathbf{j} + F_{1z}\mathbf{k} \quad \mathbf{F}_2 = F_{2x}\mathbf{i} + F_{2y}\mathbf{j} + F_{2z}\mathbf{k}$$

Their dot product is given by

$$\mathbf{F}_1 \cdot \mathbf{F}_2 = (F_{1x}\mathbf{i} + F_{1y}\mathbf{j} + F_{1z}\mathbf{k}) \cdot (F_{2x}\mathbf{i} + F_{2y}\mathbf{j} + F_{2z}\mathbf{k})$$

The right-hand side may be simplified by noting that the distributive law holds and employing the values of $\mathbf{i} \cdot \mathbf{i}$, etc., found in Prob. 1.84.

$$\mathbf{F}_1 \cdot \mathbf{F}_2 = F_{1x}F_{2x} + F_{1y}F_{2y} + F_{1z}F_{2z}$$

To check that $\mathbf{F}_1 \cdot \mathbf{F}_2$ is just the quantity $F_1F_2 \cos \theta$, where θ is the angle between \mathbf{F}_1 and \mathbf{F}_2 , multiply and divide the right side through by F_1F_2 , giving

$$\mathbf{F}_1 \cdot \mathbf{F}_2 = F_1F_2 \left(\frac{F_{1x}F_{2x}}{F_1F_2} + \frac{F_{1y}F_{2y}}{F_1F_2} + \frac{F_{1z}F_{2z}}{F_1F_2} \right) = F_1F_2(l_1l_2 + m_1m_2 + n_1n_2)$$

Now, the familiar addition formula in two dimensions,

$$\cos \theta = \cos(\theta_1 - \theta_2) = \cos \theta_1 \cos \theta_2 + \sin \theta_1 \sin \theta_2 = l_1l_2 + m_1m_2$$

extends to three dimensions as $\cos \theta = l_1l_2 + m_1m_2 + n_1n_2$. Hence, the above becomes $F_1F_2 \cos \theta$, and this method of multiplication is, as expected, in accord with the definition of the dot product.

1.86 Let $\mathbf{F}_1 = 10\mathbf{i} - 15\mathbf{j} - 20\mathbf{k}$, $\mathbf{F}_2 = 6\mathbf{i} + 8\mathbf{j} - 12\mathbf{k}$. Find their dot product and the angle between them.

▮
$$\mathbf{F}_1 \cdot \mathbf{F}_2 = (10)(6) + (-15)(8) + (-20)(-12) = 180$$

Now note that $F_1 = (10^2 + 15^2 + 20^2)^{1/2} = 26.93$, $F_2 = 15.62$. Hence, the angle θ between \mathbf{F}_1 and \mathbf{F}_2 is given by

$$\cos \theta = \frac{\mathbf{F}_1 \cdot \mathbf{F}_2}{F_1F_2} = \frac{180}{(26.93)(15.62)} = 0.4279 \quad \theta = 64.66^\circ$$

Of course, the same value can be obtained from $\cos \theta = l_1l_2 + m_1m_2 + n_1n_2$.

1.87 Find the projection of any vector along a straight line.

▮ The projection of vector $\mathbf{A} = (A_x, A_y, A_z)$ along the line determined by the radius vector $\mathbf{r} = (x, y, z)$ is $A_r = A \cos \theta$, where θ is the angle between \mathbf{r} and \mathbf{A} . From the definition of the dot product, $\mathbf{A} \cdot \mathbf{r} = (Ar \cos \theta) = A_r r$. Hence, writing $\hat{\mathbf{r}} = (1/r)\mathbf{r} = (l, m, n)$ —a unit vector along \mathbf{r} —we have $A_r = \mathbf{A} \cdot \hat{\mathbf{r}} = A_x l + A_y m + A_z n$. This expression for A_r remains valid even when the line does not pass through the origin.

1.88 Find the projection of $\mathbf{A} = 10\mathbf{i} + 8\mathbf{j} - 6\mathbf{k}$ along $\mathbf{r} = 5\mathbf{i} + 6\mathbf{j} + 9\mathbf{k}$.

▮ Here $r = (5^2 + 6^2 + 9^2)^{1/2} = 11.92$ and Prob. 1.87 gives

$$A_r = A_x l + A_y m + A_z n = 10 \left(\frac{5}{11.92} \right) + 8 \left(\frac{6}{11.92} \right) - 6 \left(\frac{9}{11.92} \right) = \frac{44}{11.92} = 3.69$$

1.89 Define the cross product (or vector product) of two vectors.

▮ The *cross product* of two vectors, as \mathbf{F}_1 and \mathbf{F}_2 , Fig. 1-36, written as $\mathbf{F} = \mathbf{F}_1 \times \mathbf{F}_2$, is defined as a vector \mathbf{F} having a magnitude $F = F_1 F_2 \sin \theta$ and a direction which is the direction of advance of a right-hand screw when turned from \mathbf{F}_1 to \mathbf{F}_2 through angle θ , it being assumed that the axis of the screw is normal to the plane determined by \mathbf{F}_1 and \mathbf{F}_2 (the *right-hand screw rule*). Or, if the curled fingers of the right hand point from \mathbf{F}_1 to \mathbf{F}_2 , the extended thumb points in the direction of \mathbf{F} (*right-hand rule*).

Note that in accord with the right-hand screw rule, $\mathbf{F}_1 \times \mathbf{F}_2 = -(\mathbf{F}_2 \times \mathbf{F}_1)$.

1.90 Find the cross products of the coordinate unit vectors.

▮ Since $\mathbf{i}, \mathbf{j}, \mathbf{k}$ are mutually perpendicular and of unit magnitude, it follows from the definition of the cross product that

$$\mathbf{i} \times \mathbf{i} = \mathbf{j} \times \mathbf{j} = \mathbf{k} \times \mathbf{k} = 0$$

$$\mathbf{i} \times \mathbf{j} = \mathbf{k} \quad \mathbf{j} \times \mathbf{k} = \mathbf{i} \quad \mathbf{k} \times \mathbf{i} = \mathbf{j} \quad \mathbf{j} \times \mathbf{i} = -\mathbf{k} \quad \mathbf{k} \times \mathbf{j} = -\mathbf{i} \quad \mathbf{i} \times \mathbf{k} = -\mathbf{j}$$

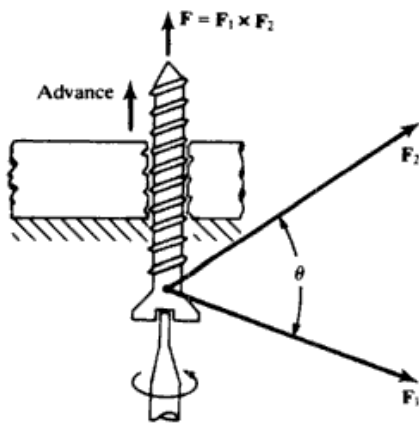

Fig. 1-36

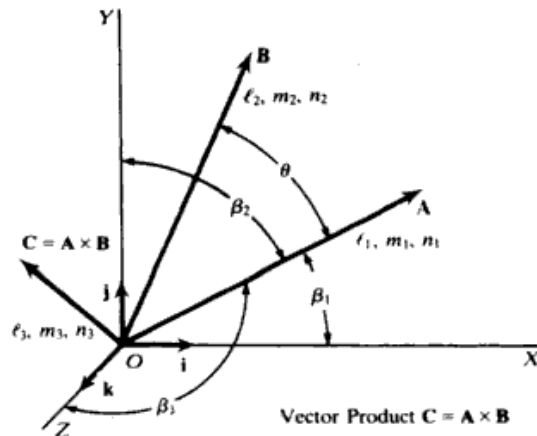

Fig. 1-37

1.91 Given two vectors, as in Fig. 1-37,

$$\mathbf{A} = A_x \mathbf{i} + A_y \mathbf{j} + A_z \mathbf{k} \quad \mathbf{B} = B_x \mathbf{i} + B_y \mathbf{j} + B_z \mathbf{k}$$

find their cross product in rectangular coordinates.

▮
$$\mathbf{C} = \mathbf{A} \times \mathbf{B} = (A_x \mathbf{i} + A_y \mathbf{j} + A_z \mathbf{k}) \times (B_x \mathbf{i} + B_y \mathbf{j} + B_z \mathbf{k})$$

Applying the distributive law to the right-hand side and using the values of $\mathbf{i} \times \mathbf{i}$, etc., found in Prob. 1.90, we obtain

$$\mathbf{C} = \mathbf{A} \times \mathbf{B} = (A_y B_z - A_z B_y) \mathbf{i} + (A_z B_x - A_x B_z) \mathbf{j} + (A_x B_y - A_y B_x) \mathbf{k}$$

Equivalently, $\mathbf{A} \times \mathbf{B}$ may be expressed as a determinant:

$$\mathbf{C} = \mathbf{A} \times \mathbf{B} = \begin{vmatrix} \mathbf{i} & \mathbf{j} & \mathbf{k} \\ A_x & A_y & A_z \\ B_x & B_y & B_z \end{vmatrix}$$

as may be verified by expanding the determinant with respect to the first row. Note that the X, Y, Z components of \mathbf{C} are

$$C_x = A_y B_z - A_z B_y \quad C_y = (A_z B_x - A_x B_z) \quad C_z = A_x B_y - A_y B_x$$

Hence the magnitude of \mathbf{C} is $C = (C_x^2 + C_y^2 + C_z^2)^{1/2}$ and its direction cosines are

$$l = \frac{C_x}{C} \quad m = \frac{C_y}{C} \quad n = \frac{C_z}{C}$$

Vector \mathbf{C} is, of course, normal to the plane of vectors \mathbf{A} and \mathbf{B} .

- 1.92 Assuming that vectors **A** and **B**, Fig. 1-38, are in the *XY* plane, determine the magnitude and direction of $\mathbf{C} = \mathbf{A} \times \mathbf{B}$.

| $C = (200)(100) \sin(55^\circ - 15^\circ) = 20\,000 \sin 40^\circ = 12\,855$

and by the right-hand rule the direction of **C** is that of +*Z*. Vectorially we can write $\mathbf{C} = 12\,885\mathbf{k}$.

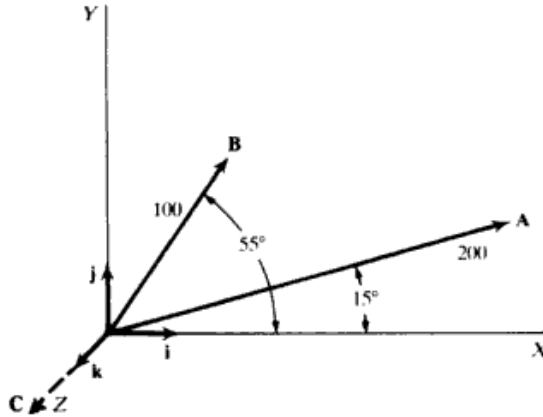

Fig. 1-38

- 1.93 Referring to Fig. 1-37, let $\mathbf{A} = 20\mathbf{i} - 10\mathbf{j} + 30\mathbf{k}$ and $\mathbf{B} = -6\mathbf{i} + 15\mathbf{j} - 25\mathbf{k}$. (a) Find the magnitudes of **A** and **B**. (b) Find the direction cosines of **A**. (c) Find the vector product $\mathbf{C} = \mathbf{A} \times \mathbf{B}$. (d) Find the magnitude and direction of **C**. (e) Find angle θ between **A** and **B** (f) Find the values of the direction cosines l_2, m_2, n_2 of **B**, and find angles $\alpha_{21}, \alpha_{22}, \alpha_{23}$ between **B** and the *X*, *Y*, and *Z* axes, respectively.

| (a) $A = (20^2 + 10^2 + 30^2)^{1/2} = 37.42$ $B = 29.77$

(b) $l_1 = \frac{20}{37.42}$ $m_1 = \frac{-10}{37.42}$ $n_1 = \frac{30}{37.42}$

(c) Applying the determinant formula,

$$\mathbf{C} = \begin{vmatrix} \mathbf{i} & \mathbf{j} & \mathbf{k} \\ 20 & -10 & 30 \\ -6 & 15 & -25 \end{vmatrix}$$

$$\begin{aligned} \mathbf{C} &= \mathbf{i}[(-10)(-25) - (15)(30)] - \mathbf{j}[(20)(-25) - (30)(-6)] + \mathbf{k}[(20)(15) - (-10)(-6)] \\ &= -200\mathbf{i} + 320\mathbf{j} + 240\mathbf{k} = 200(-\mathbf{i} + 1.6\mathbf{j} + 1.2\mathbf{k}) \end{aligned}$$

(d) The magnitude of **C** is $C = 200(1^2 + 1.6^2 + 1.2^2)^{1/2} = 447.21$

The direction cosines are $l_3 = \frac{-200}{447.21}$ $m_3 = \frac{320}{447.21}$ $n_3 = \frac{240}{447.21}$

Note that $\mathbf{C} = C(l_3\mathbf{i} + m_3\mathbf{j} + n_3\mathbf{k})$.

(e) $C = AB \sin \theta$ $447.21 = (37.42)(29.77) \sin \theta$ $\sin \theta = 0.40145$ $\theta = 23.67^\circ$

(f) $\mathbf{B} = -6\mathbf{i} + 15\mathbf{j} - 25\mathbf{k} = B(l_2\mathbf{i} + m_2\mathbf{j} + n_2\mathbf{k})$

Thus $B l_2 = -6$ $B m_2 = 15$ $B n_2 = -25$ $B = (6^2 + 15^2 + 25^2)^{1/2} = 29.766$
 $l_2 = -0.2016$ $m_2 = 0.5039$ $n_2 = -0.8399$

Corresponding angles are $\alpha_{21} = 101.63^\circ$ $\alpha_{22} = 59.74^\circ$ $\alpha_{23} = 147.13^\circ$

CHAPTER 2

Equilibrium of Concurrent Forces

2.1 ROPES, KNOTS, AND FRICTIONLESS PULLEYS

2.1 The object in Fig. 2-1(a) weighs 50 N and is supported by a cord. Find the tension in the cord.

| Two forces act upon the object, the upward pull of the cord and the downward pull of gravity. Represent the pull of the cord by T , the tension in the cord. The pull of gravity, the weight of the object, is $w = 50$ N. These two forces are shown in the free-body diagram, Fig. 2-1(b).

The forces are already in component form and so we can write the first condition for equilibrium at once.

$$\begin{aligned} \sum F_x = 0 & \text{ becomes } 0 = 0 \\ \sum F_y = 0 & \text{ becomes } T - 50 \text{ N} = 0 \end{aligned}$$

from which $T = 50$ N.

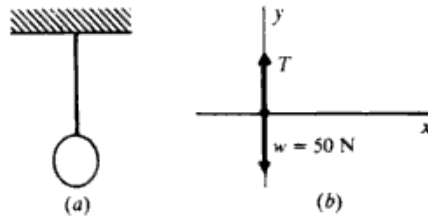

Fig. 2-1

2.2 As shown in Fig. 2-2(a), the tension in the horizontal cord is 30 N. Find the weight of the object.

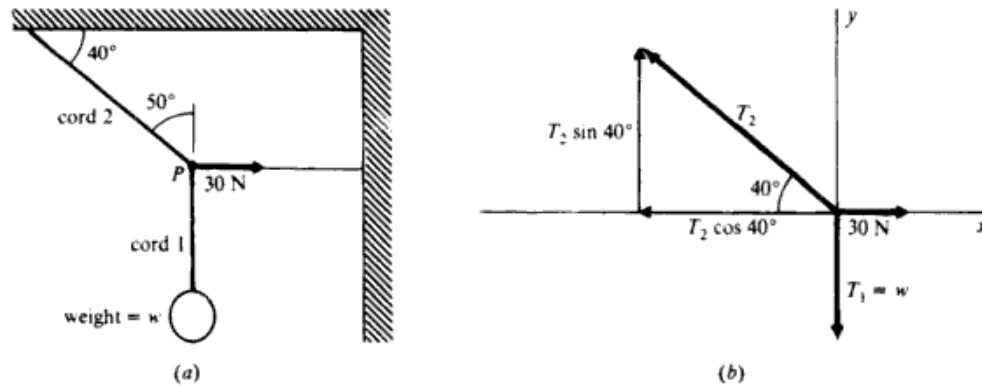

Fig. 2-2

| As seen in Prob. 2.1, the tension in cord 1 is equal to the weight of the object hanging from it. Therefore $T_1 = w$, and we wish to find T_1 or w .

Note that the unknown force, T_1 , and the known force, 30 N, both pull on the knot at point P . It therefore makes sense to isolate the knot at P as our object. The free-body diagram showing the forces on the knot is drawn as Fig. 2-2(b). The force components are also found there.

Next write the first condition for equilibrium for the knot. From the free-body diagram,

$$\begin{aligned} \sum F_x = 0 & \text{ becomes } 30 \text{ N} - T_2 \cos 40^\circ = 0 \\ \sum F_y = 0 & \text{ becomes } T_2 \sin 40^\circ - w = 0 \end{aligned}$$

Solving the first equation for T_2 gives $T_2 = 39.2$ N. Substituting this value in the second equation gives $w = 25.2$ N as the weight of the object.

2.3 For the system of Fig. 2-3(a), find the values of T_1 and T_2 if the weight is 600 N.

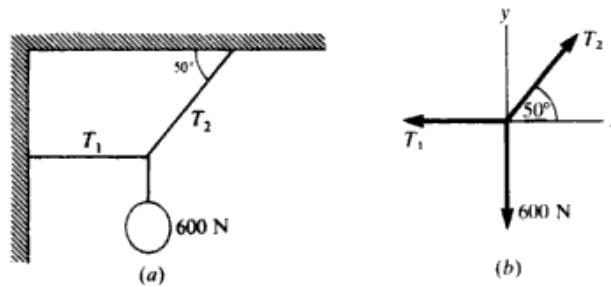

Fig. 2-3

■ Consider the knot to be in equilibrium under the action of three forces, as shown in Fig. 2-3(b).

$$\begin{aligned} \sum F_x = 0 & \text{ yields } T_2 \cos 50^\circ - T_1 = 0 & \text{ or } 0.643T_2 = T_1 \\ \sum F_y = 0 & \text{ yields } T_2 \sin 50^\circ - 600 \text{ N} = 0 & \text{ or } 0.766T_2 = 600 \text{ N} \end{aligned}$$

This gives $T_2 = 783 \text{ N}$. Substituting into the $\sum F_x$ equation yields $T_1 = 503 \text{ N}$.

2.4 The following coplanar forces pull on a ring: 200 N at 30° , 500 N at 80° , 300 N at 240° , and an unknown force. Find the magnitude and direction of the unknown force if the ring is to be in equilibrium.

■ Assume that the 0° line is the x axis and 90° specifies the y axis. The three known forces are then as shown in Fig. 2-4. If F_4 is the unknown force, then $F_1 + F_2 + F_3 + F_4 = 0$. Let $R = F_1 + F_2 + F_3$, then $R + F_4 = 0 \Rightarrow F_4 = -R$. To find F_4 , we need only find R .

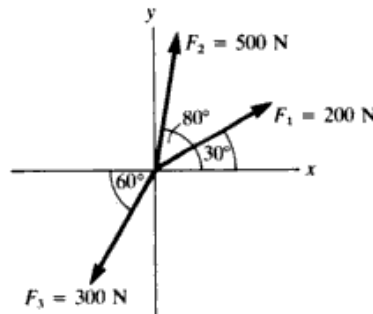

Fig. 2-4

$$\begin{aligned} R_x = F_{1x} + F_{2x} + F_{3x} &= F_1 \cos 30^\circ + F_2 \cos 80^\circ - F_3 \cos 60^\circ, & R_x &= 200(0.866) + 500(0.174) - 300(0.500) = 110 \text{ N} \\ R_y = F_{1y} + F_{2y} + F_{3y} &= F_1 \sin 30^\circ + F_2 \sin 80^\circ - F_3 \sin 60^\circ, & R_y &= 200(0.500) + 500(0.985) - 300(0.866) = 333 \text{ N}, & R &= (R_x^2 + R_y^2)^{1/2} = \\ & & & & & \underline{351 \text{ N}}, & \tan \theta_R = \frac{R_y}{R_x} \Rightarrow \theta_R = 71.7^\circ, & F_4 = R & \text{ and } \theta_{F_4} = \theta_R + 180^\circ = \underline{252^\circ} \end{aligned}$$

2.5 In Fig. 2-5(a) the value of W is 180 N. Find the tensions in ropes A and B .

■ Refer to Fig. 2-5(b). Summing forces in the x and y directions to zero yields $A = B \cos 53^\circ$ and $B \sin 53^\circ = W = 180$. From the latter, $B = 225 \text{ N}$, which when inserted into the former gives $A = 135 \text{ N}$.

2.6 If the identical ropes A and B in Fig. 2-5(a) can each support tensions no larger than 200 N, what is the maximum value that W can have? What is the tension in the other rope when W has this maximum value?

■ From Prob. 2.5, B will experience the largest tension, 200 N in this case. Solve for forces along the vertical: $W = 200 \sin 53^\circ = 160 \text{ N}$, and in the horizontal direction find $A = 200 \cos 53^\circ = 120 \text{ N}$.

2.7 A rope extends between two poles. A 90-N boy hangs from it, as shown in Fig. 2-6(a). Find the tensions in the two parts of the rope.

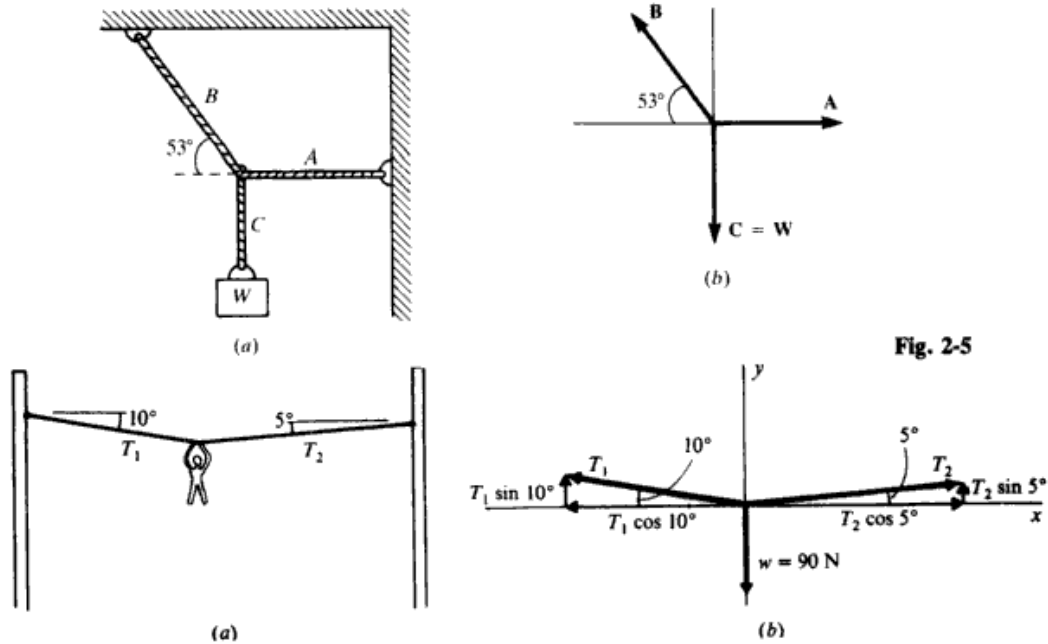

Fig. 2-6

Fig. 2-5

Label the two tensions T_1 and T_2 , and isolate the rope at the boy's hands as the object. The free-body diagram for this object is shown in Fig. 2-6(b).

$$\begin{aligned} \sum F_x = 0 & \text{ becomes } T_2 \cos 5^\circ - T_1 \cos 10^\circ = 0 \\ \sum F_y = 0 & \text{ becomes } T_2 \sin 5^\circ + T_1 \sin 10^\circ - 90 \text{ N} = 0 \end{aligned}$$

Evaluating the sines and cosines, these equations become

$$0.996T_2 - 0.985T_1 = 0 \quad \text{and} \quad 0.087T_2 + 0.174T_1 - 90 = 0$$

Solving the first for T_2 gives $T_2 = 0.989T_1$. Substituting this in the second equation gives

$$0.086T_1 + 0.174T_1 - 90 = 0$$

from which $T_1 = 346 \text{ N}$. Then, because $T_2 = 0.989T_1$, we have $T_2 = 342 \text{ N}$.

2.8 The tension in cord A in Fig. 2-7 is 30 N. Find the tension in B and the value of W.

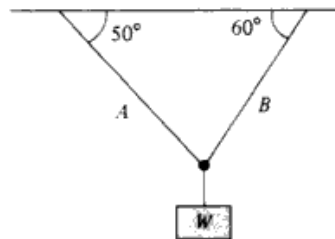

Fig. 2-7

Draw a free-body diagram for the point on the rope where the cords meet; the equilibrium relations in the x and y directions are $T_A \cos 50^\circ = T_B \cos 60^\circ$ and $W = T_A \sin 50^\circ + T_B \sin 60^\circ$, where $T_A = 30 \text{ N}$. Solving: $T_B = 39 \text{ N}$ and $W = 56 \text{ N}$.

2.9 In Fig. 2-7, how large are T_A and T_B if $W = 80 \text{ N}$?

The equilibrium equations have already been obtained in Prob. 2.8. The y-equilibrium equation when $W = 80 \text{ N}$ is $80 = T_A[\sin 50^\circ + (\tan 60^\circ)(\cos 50^\circ)]$, where we have substituted for T_B from the horizontal equation. Thus the tensions are $T_A = 43 \text{ N}$ and $T_B = 55 \text{ N}$.

2.10 A boy of weight W hangs from the center of a clothesline and distorts the line so that it makes 20° angles with the horizontal at each end. Find the tension in the clothesline in terms of W .

▮ From Fig. 2-8, $2T \sin 20^\circ = W$. Therefore $T = 1.46W$.

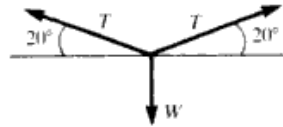

Fig. 2-8

2.11 In shooting an arrow from a bow, an archer holds the bow vertical and pulls back on the arrow with a force of 80 N. The two halves of the string make 25° angles with the vertical. What is the tension in the string?

▮ Setting horizontal forces to zero at the point on the string held by the archer we obtain $80 = 2T \sin 25^\circ$, whence $T = 95 \text{ N}$.

2.12 In Fig. 2-9(a), the pulleys are frictionless and the system hangs at equilibrium. If w_3 is a 200 N weight, what are the values of w_1 and w_2 ?

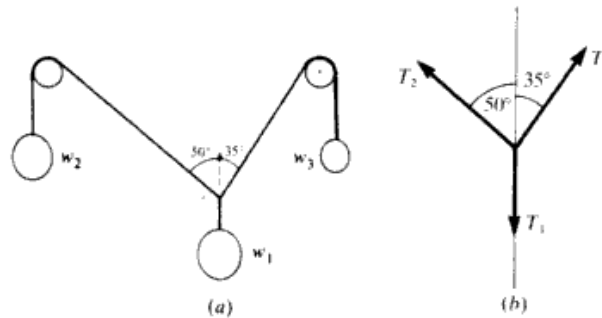

Fig. 2-9

▮ The knot above w_1 is in equilibrium under the action of three forces, as shown in Fig. 2-9(b). Since the pulleys are frictionless, $T_2 = w_2$; $T_3 = w_3$. Also $T_1 = w_1$. We are given $T_3 = w_3 = 200 \text{ N}$. From $\sum F_x = 0$, $T_3 \sin 35^\circ - T_2 \sin 50^\circ = 0$. (Note the x -component equation involves sine functions because angles are with respect to y axis.) Then $200(0.574) = T_2(0.766) \Rightarrow T_2 = 150 \text{ N} = w_2$. From $\sum F_y = 0$, $T_3 \cos 35^\circ + T_2 \cos 50^\circ - T_1 = 0$ or $200(0.819) + 150(0.643) = T_1 \Rightarrow T_1 = 260 \text{ N} = w_1$.

2.13 Suppose w_1 in Fig. 2-9(a) weighs 500 N. Find the values of w_2 and w_3 if the system is to hang in equilibrium.

▮ Now $T_1 = 500 \text{ N}$ in Fig. 2-9(b). $\sum F_x = 0 \Rightarrow T_3 \sin 35^\circ - T_2 \sin 50^\circ = 0 \Rightarrow 0.574T_3 = 0.766T_2$. Or solving for T_3 ,

$$T_3 = 1.33T_2 \tag{1}$$

$\sum F_y = 0 \Rightarrow T_3 \cos 35^\circ + T_2 \cos 50^\circ - T_1 = 0 \Rightarrow 0.819T_3 + 0.643T_2 = 500 \text{ N}$. Substituting $1.33T_2$ for T_3 we have

$$0.819(1.33T_2) + 0.643T_2 = 500 \text{ N} \Rightarrow 1.73T_2 = 500 \text{ N} \quad T_2 = 289 \text{ N}$$

From (1), we get $T_3 = 384 \text{ N}$.

2.14 Find the tensions in the ropes shown in Fig. 2-10 if the supported object weighs 600 N.

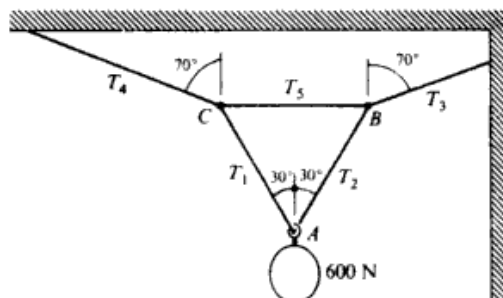

Fig. 2-10

▮ Let us select as our object the knot at *A* because we know one force acting on it. The weight pulls down on it with a force of 600 N and so the free-body diagram for the knot is as shown in Fig. 2-11(a). Applying the first condition for equilibrium to that diagram, we have

$$\sum F_x = 0 \quad \text{or} \quad T_2 \cos 60^\circ - T_1 \cos 60^\circ = 0 \quad \sum F_y = 0 \quad \text{or} \quad T_1 \sin 60^\circ + T_2 \sin 60^\circ - 600 = 0$$

The first equation yields $T_1 = T_2$. Substitution of T_1 for T_2 in the second equation gives $T_1 = 346 \text{ N}$, and this is also T_2 .

Let us now isolate knot *B* as our object. Its free-body diagram is shown in Fig 2-11(b). We have already found that $T_2 = 346 \text{ N}$ and so the equilibrium equations are

$$\sum F_x = 0 \quad \text{or} \quad T_3 \cos 20^\circ - T_3 - 346 \sin 30^\circ = 0$$

$$\sum F_y = 0 \quad \text{or} \quad T_3 \sin 20^\circ - 346 \cos 30^\circ = 0$$

The last equation yields $T_3 = 877 \text{ N}$. Substituting this in the prior equation gives $T_3 = 651 \text{ N}$.

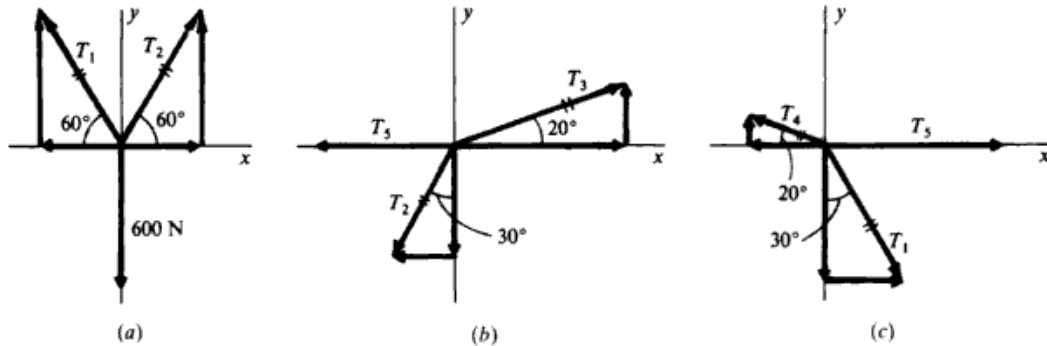

Fig. 2-11

We can now proceed to the knot at *C* and the free-body diagram of Fig 2-11(c). Recalling that $T_1 = 346 \text{ N}$,

$$\sum F_x = 0 \quad \text{becomes} \quad T_5 + 346 \sin 30^\circ - T_4 \cos 20^\circ = 0$$

$$\sum F_y = 0 \quad \text{becomes} \quad T_4 \sin 20^\circ - 346 \cos 30^\circ = 0$$

The latter equation yields $T_4 = 877 \text{ N}$.

[Note that from the symmetry of the system we could have deduced $T_1 = T_2$ and $T_4 = T_5$.]

- 2.15 If $w = 40 \text{ N}$ in the equilibrium situation shown in Fig. 2-12(a) find T_1 and T_2 .

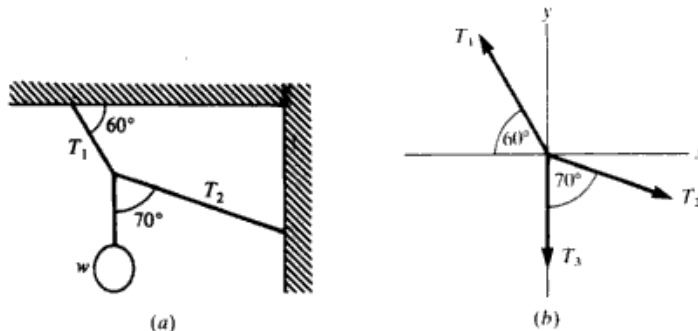

Fig. 2-12

▮ The knot is in equilibrium under the action of three forces, and the free-body diagram is as shown in Fig. 2-12(b). $T_3 = w = 40 \text{ N}$.

$$\sum F_x = 0 \Rightarrow T_2 \sin 70^\circ - T_1 \cos 60^\circ = 0 \quad \text{or} \quad (0.940)T_2 = (0.500)T_1, \quad T_1 = 1.88T_2$$

$$\sum F_y = 0 \Rightarrow T_1 \sin 60^\circ - T_2 \cos 70^\circ - T_3 = 0, \quad (0.866)T_1 - (0.342)T_2 = T_3 = 40 \text{ N}$$

Substituting for T_1 ,

$$(0.866)(1.88T_2) - (0.342)T_2 = 40 \text{ N} \quad 1.29T_2 = 40 \text{ N} \quad T_2 = \underline{31.0 \text{ N}} \quad \text{and} \quad T_1 = (1.88)(31.0) = \underline{58.3 \text{ N}}$$

- 2.16** Refer to Fig. 2-12(a). The cords are strong enough to withstand a maximum tension of 80 N. What is the largest value of w that they can support as shown?

▮ From Prob. 2.15 the equilibrium equations are, for any w_1 ,

$$T_1 = 1.88T_2 \tag{1}$$

$$0.866T_1 - 0.342T_2 = w \tag{2}$$

From Eq. (1) it is clear that $T_1 > T_2$ always. Therefore T_1 will reach the breaking point first. We thus set $T_1 = 80 \text{ N}$ to find the corresponding w . From (1),

$$1.88T_2 = 80 \text{ N} \Rightarrow T_2 = \underline{42.6}$$

From (2), $w = (0.866)(80 \text{ N}) - (0.342)(42.6 \text{ N}) = \underline{54.7 \text{ N}}$

- 2.17** The weight W_1 in Fig. 2-13(a) is 300 N. Find T_1 , T_2 , T_3 , and W_2 .

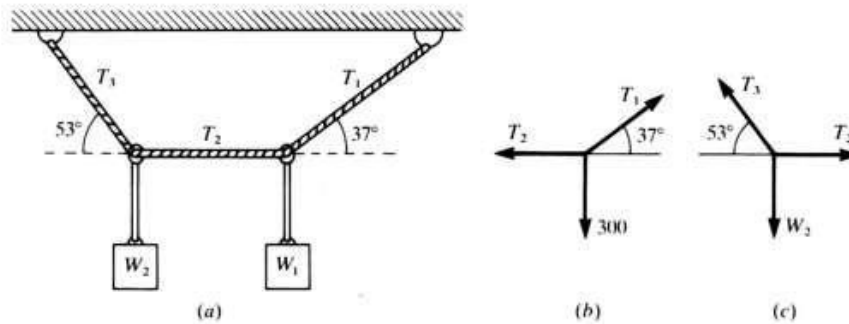

Fig. 2-13

▮ From Fig. 2-13(b): $T_1 \sin 37^\circ = 300$ so $T_1 = \underline{500 \text{ N}}$. Also, $T_2 = T_1 \cos 37^\circ = \underline{400 \text{ N}}$. From Fig. 2-13(c), $T_3 \cos 53^\circ = T_2$, so $T_3 = \underline{670 \text{ N}}$. But $T_3 \sin 53^\circ = W_2$, so $W_2 = \underline{530 \text{ N}}$. (Note answers are to two-place accuracy).

- 2.18** If $\theta_1 = \theta_2$ in Fig. 2-14, what can be said about T_1 , T_2 , T_3 , W_1 , and W_2 provided the pulley is frictionless?

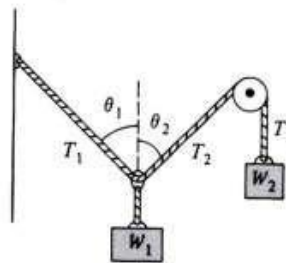

Fig. 2-14

▮ Where the three ropes join, $T_1 \sin \theta_1 = T_2 \sin \theta_2$, so $T_1 = T_2$. Also $T_2 = T_3$ and $W_2 = T_3$. Further, the equilibrium condition for the vertical direction is $W_1 = 2T_1 \cos \theta_1$. Therefore $T_1 = T_2 = T_3 = W_2 = W_1 / (2 \cos \theta_1)$.

- 2.19** In reference to Fig. 2-14, if $\theta_1 = 53^\circ$ and $\theta_2 = 37^\circ$, how large is W_1 in comparison to W_2 ?

▮ Since $T_2 = T_3 = W_2$, the equilibrium equations are $W_2 \sin 37^\circ = T_1 \sin 53^\circ$ and $T_1 \cos 53^\circ + W_2 \cos 37^\circ = W_1$. Solving for T_1 in the first equation and placing it into the second yields $W_1 = \underline{1.25W_2}$.

- 2.20** Suppose that $W_1 = W_2$ in Fig. 2-14 and that $\theta_1 = 53^\circ$. Find θ_2 .

▮ The equilibrium equations are $W_2 \sin \theta_2 = T_1 \sin 53^\circ$ and $T_1 \cos 53^\circ + W_2 \cos \theta_2 = W_2$. Eliminating T_1 in the

second equation by use of the first yields

$$\sin \theta_2 \cos 53^\circ + \cos \theta_2 \sin 53^\circ = \sin 53^\circ \quad \text{or} \quad \sin (\theta_2 + 53^\circ) = \sin 53^\circ$$

Thus, either $\theta_2 = 0$ [the two weights are on the same vertical line and $T_1 = 0$] or else $(\theta_2 + 53^\circ) + 53^\circ = 180^\circ \Rightarrow \theta_2 = 74^\circ$ [the "normal" answer].

2.21 Refer to Fig. 2-15(a). What is the tension in cord \overline{AB} ?

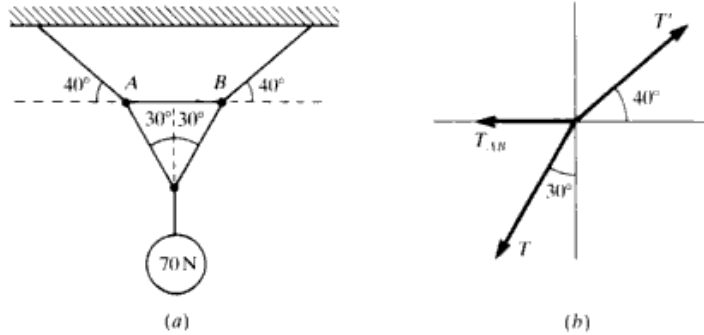

Fig. 2-15

First find the tension in the cords below the cord in question by balancing vertical forces at the lower junction in Fig. 2-15(a): $2T \cos 30^\circ = 70$, so $T = 40.4$ N. Equilibrium conditions for junction B [Fig. 2-15(b)] are $T' \cos 40^\circ = T_{AB} + T \sin 30^\circ$; $T' \sin 40^\circ = T \cos 30^\circ$. Substituting for T and eliminating T' from the two relations yields $T_{AB} = 21.5$ N. From symmetry the same equations are found at junction A.

2.22 The weight w in Fig. 2-16(a) is 80 N and is in equilibrium. Find T_1 , T_2 , T_3 , and T_4 .

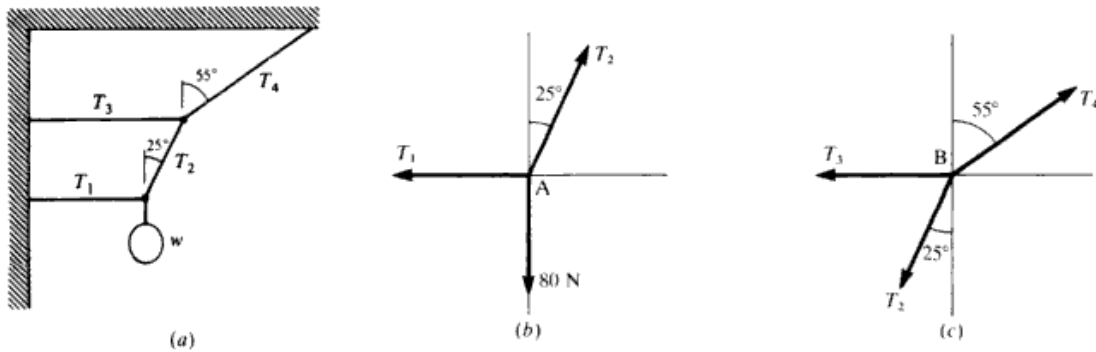

Fig. 2-16

Labeling the lower knot A and the upper knot B, we have the free-body diagrams of Fig. 2-16(b) and (c). We address the equilibrium of knot A first because it involves the only known force.

$$\begin{aligned} \sum F_x = 0 &\Rightarrow T_2 \sin 25^\circ - T_1 = 0 & T_1 &= 0.423 T_2 \\ \sum F_y = 0 &\Rightarrow T_2 \cos 25^\circ - 80 \text{ N} = 0 & 0.906 T_2 &= 80 \text{ N} & T_2 &= \underline{88.3 \text{ N}} \end{aligned}$$

Then from before, $T_1 = 37.4$ N.

Turning now to knot B, and remembering that we know T_2 ,

$$\sum F_x = 0 \Rightarrow T_4 \sin 55^\circ - T_3 - T_2 \sin 25^\circ = 0$$

or

$$0.819 T_4 - T_3 = 0.423 T_2 = 37.4 \text{ N} \tag{1}$$

$$\sum F_y = 0 \Rightarrow T_4 \cos 55^\circ - T_2 \cos 25^\circ = 0 \Rightarrow 0.573 T_4 = 80 \text{ N} \Rightarrow T_4 = \underline{140 \text{ N}}$$

From (1), $T_3 = 0.819 T_4 - 37.4 = 77$ N.

- 2.23 The pulleys shown in Fig. 2-17(a) have negligible weight and friction. What is the value of w if it remains supported as shown by the 70-N weight?

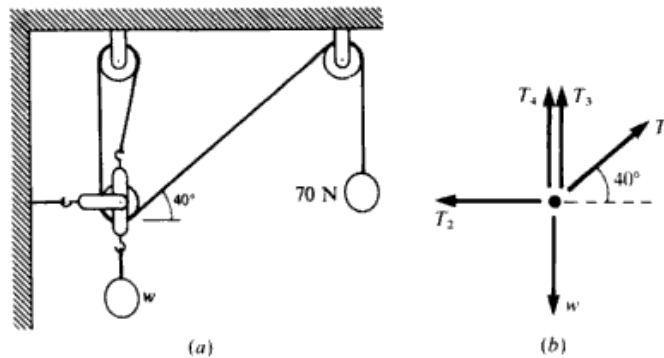

Fig. 2-17

■ Consider the lower pulley system (just above weight w) as the system in equilibrium. Since it is weightless, it is in equilibrium under the action of five forces, as shown in Fig. 2-17(b). T_3 and T_4 and T_1 are due to the common cord wrapped about the ceiling pulley directly above, around the system pulley, and around the other ceiling pulley, and finally connected to the 70-N weight. Since the pulleys are frictionless, $T_1 = T_3 = T_4 = 70$ N. For the body in equilibrium,

$$\sum F_x = 0 \Rightarrow T_1 \cos 40^\circ - T_2 = 0 \Rightarrow T_2 = (0.766)(70 \text{ N}) = \underline{53.6 \text{ N}}$$

$$\sum F_y = 0 \Rightarrow T_3 + T_4 + T_1 \sin 40^\circ - w = 0 \Rightarrow w = 70 \text{ N} + 70 \text{ N} + (70 \text{ N})(0.642) = \underline{185 \text{ N}}$$

- 2.24 How large is the force that stretches the patient's leg in Fig. 2-18? How large an upward force does the device exert on foot and leg together? Assume frictionless and massless pulleys.

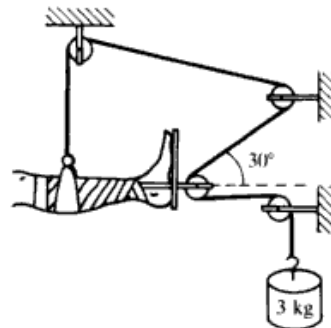

Fig. 2-18

■ 3 kg weighs about 30 N. Since the pulleys are frictionless and with negligible mass, the tension T in the cord is the same everywhere. T holds up the weight, so $T = 30$ N. The forces on the leg and foot from the device are caused by the tensions in the cord. The horizontal or stretching force is $T + T \cos 30^\circ = \underline{56 \text{ N}}$, while the upward force is $T + T \sin 30^\circ = \underline{45 \text{ N}}$.

- 2.25 For the situation shown in Fig. 2-19, with what force must the 600-N man pull downward on the rope to support himself free from the floor? Assume the pulleys have negligible friction and weight.
- Call T the tension in the rope the man is holding; T is the same throughout the one piece of rope. The other vertical force on the man is the tension in the rope attached to the pulley above the man's head, which must be $2T$ for the pulley in equilibrium. The net vertical force is $3T$, which is balanced by his weight of 600 N. Therefore the man exerts a downward pull of 200 N.

- 2.26 In the setup of Fig. 2-20, the mobile pulley and the fixed pulley, both frictionless, are associated with equal weights w . Find the angle θ .

■ Since the tension in the cord is w , the condition for vertical equilibrium of the mobile pulley is $2w \sin \theta = w$, or $\sin \theta = \frac{1}{2}$, or $\theta = 30^\circ$.

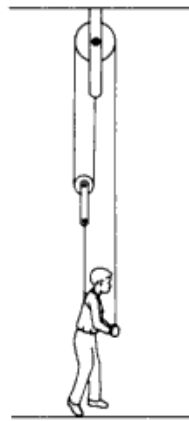

Fig. 2-19

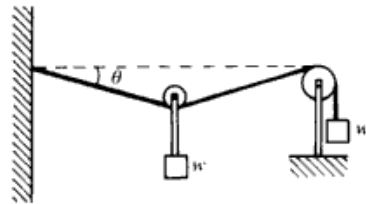

Fig. 2-20

2.2 FRICTION AND INCLINED PLANES

2.27 A 200-N wagon is to be pulled up a 30° incline at constant speed. How large a force parallel to the incline is needed if friction effects are negligible?

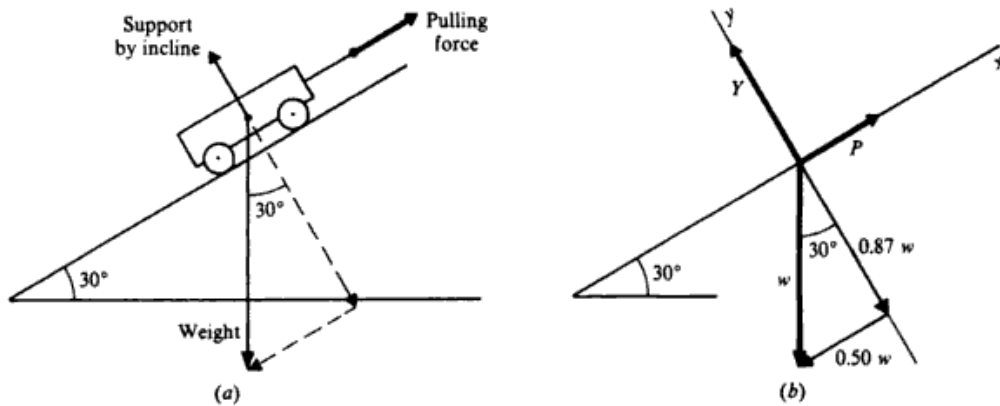

Fig. 2-21

▮ The situation is shown in Fig. 2-21(a). Because the wagon moves at constant speed along a straight line, its velocity vector is constant. Therefore the wagon is in translational equilibrium, and the first condition for equilibrium applies to it.

We isolate the wagon as the object. Three nonnegligible forces act on it: (1) the pull of gravity w (its weight), directed straight down; (2) the force P exerted on the wagon parallel to the incline to pull it up the incline; (3) the push Y of the incline that supports the wagon. These three forces are shown in the free-body diagram, Fig. 2-21(b).

For situations involving inclines, it is convenient to take the x axis parallel to the incline and the y axis perpendicular to it. After taking components along these axes, we can write the first condition for equilibrium.

$$\sum F_x = 0 \quad \text{becomes} \quad P - 0.50w = 0 \quad \sum F_y = 0 \quad \text{becomes} \quad Y - 0.87w = 0$$

Solving the first equation and recalling that $w = 200$ N, we find that $P = 0.50w = \underline{100}$ N. The required pulling force is 100 N.

- 2.28 A box weighing 100 N is at rest on a horizontal floor. The coefficient of static friction between the box and the floor is 0.4. What is the smallest force F exerted eastward and upward at an angle of 30° with the horizontal that can start the box in motion?

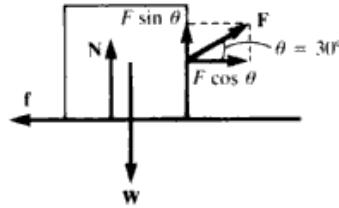

Fig. 2-22

First draw a force diagram, Fig. 2-22. Next, consider the forces in the x direction and apply the conditions for equilibrium, noting f equals its maximum value to start motion.

$$\sum F_x = 0 \quad F \cos \theta - f = 0 \quad F \cos \theta = f \quad 0.866F = f = \mu_s N = 0.4N$$

Now apply the conditions for equilibrium to the forces in y direction.

$$\sum F_y = 0 \quad N + F \sin \theta - W = 0 \quad N + 0.5F - 100 = 0 \quad N = 100 - 0.5F$$

Substituting this equation for N in $0.866F = 0.4N$ above,

$$0.866F = 0.4(100 - 0.5F) \quad 0.866F + 0.2F = 40 \quad F = \underline{37.5 \text{ N}}$$

- 2.29 A block on an inclined plane just begins to slip if the inclination of the plane is 50° . (a) What is the coefficient of static friction? (b) If the block has a mass of 2 kg, what is the actual frictional force just before it begins to slip?

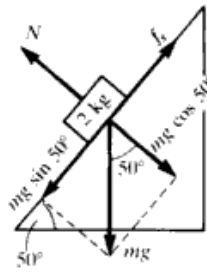

Fig. 2-23

(a) From Fig. 2-23:

$$f_{s(\max)} = mg \sin 50^\circ \quad N = mg \cos 50^\circ \quad \mu_s = f_{s(\max)}/N = \tan 50^\circ = \underline{1.192}$$

(b) $f_s = mg \sin 50^\circ = 2(9.8)(0.766) = \underline{15.0 \text{ N}}$

- 2.30 A 50-N box is slid straight across the floor at constant speed by a force of 25 N, as shown in Fig. 2-24(a). How large a friction force impedes the motion of the box? How large is the normal force?

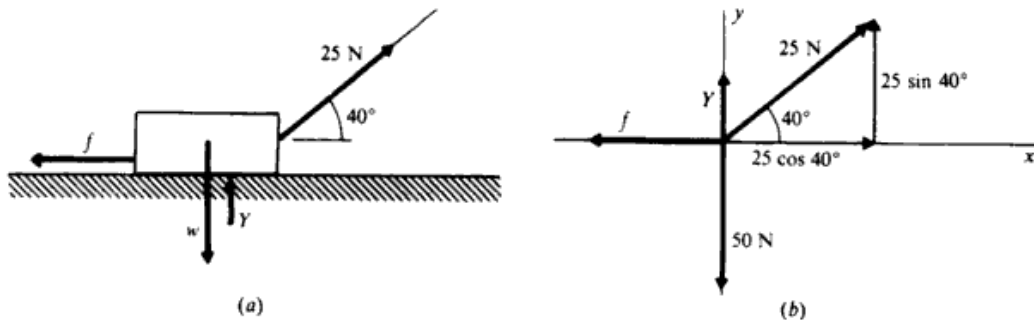

Fig. 2-24

▮ Note the forces acting on the box as shown in Fig. 2-24(a). The friction is f and the normal force, the supporting force exerted by the floor, is Y . The free-body diagram and components are shown in Fig. 2-24(b). Because the box is moving with constant velocity, it is in equilibrium. The first condition for equilibrium tells us that

$$\sum F_x = 0 \quad \text{or} \quad 25 \cos 40^\circ - f = 0$$

We can solve for f at once to find that $f = 19 \text{ N}$. The friction force is 19 N.

To find Y we use the fact that

$$\sum F_y = 0 \quad \text{or} \quad Y + 25 \sin 40^\circ - 50 = 0$$

Solving gives the normal force as $Y = 34 \text{ N}$.

2.31 Each of the objects in Fig. 2-25 is in equilibrium. Find the normal force, Y , in each case.

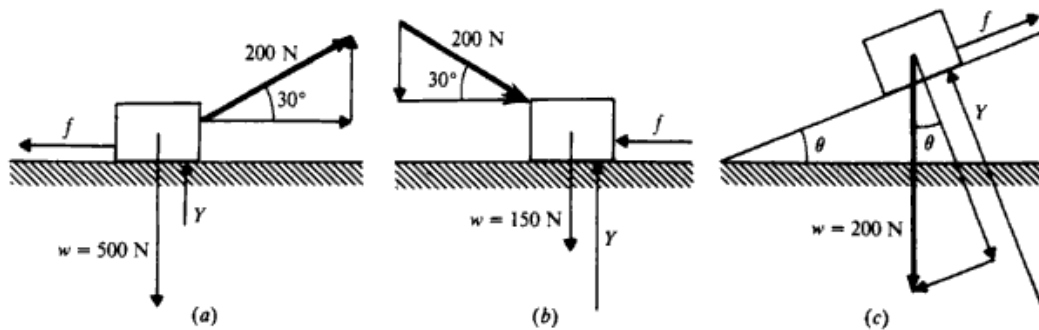

Fig. 2-25

▮ We apply $\sum F_y = 0$ in each case.

- (a) $Y + 200 \sin 30^\circ - 500 = 0$ from which $Y = 400 \text{ N}$
 (b) $Y - 200 \sin 30^\circ - 150 = 0$ from which $Y = 250 \text{ N}$
 (c) $Y - 200 \cos \theta = 0$ from which $Y = (200 \cos \theta) \text{ N}$

2.32 For the situations of Prob. 2.31, find the coefficient of kinetic friction if the object is moving with constant speed.

▮ We have already found Y for each case in Prob. 2.31. To find f , the sliding friction force, we use $\sum F_x = 0$.

- (a) $200 \cos 30^\circ - f = 0$ and so $f = 173 \text{ N}$
 Then, $\mu_k = f/Y = 173/400 = 0.43$.
 (b) $200 \cos 30^\circ - f = 0$ and so $f = 173 \text{ N}$
 Then, $\mu_k = f/Y = 173/250 = 0.69$.
 (c) $-200 \sin \theta + f = 0$ and so $f = (200 \sin \theta) \text{ N}$
 Then, $\mu_k = f/Y = (200 \sin \theta)/(200 \cos \theta) = \tan \theta$.

2.33 Suppose that in Fig. 2-25(c) the block is at rest. The angle of the incline is slowly increased. At an angle $\theta = 42^\circ$, the block begins to slide. What is the coefficient of static friction between the block and the incline? (The block and surface are not the same as in Probs. 2.31 and 2.32.)

▮ At the instant the block begins to slide, the friction force has its critical value. Therefore, $\mu_s = f/Y$ at that instant. Following the method of Probs. 2.31 and 2.32, we have

$$Y = w \cos \theta \quad \text{and} \quad f = w \sin \theta$$

Therefore, when sliding just starts,

$$\mu_s = \frac{f}{Y} = \frac{w \sin \theta}{w \cos \theta} = \tan \theta$$

But θ was found by experiment to be 42° . Therefore, $\mu_s = \tan 42^\circ = 0.90$.

- 2.34 Two weights are hung over two frictionless pulleys, as shown in Fig. 2-26(a). What weight W will cause the 300-lb block to just start moving to the right?

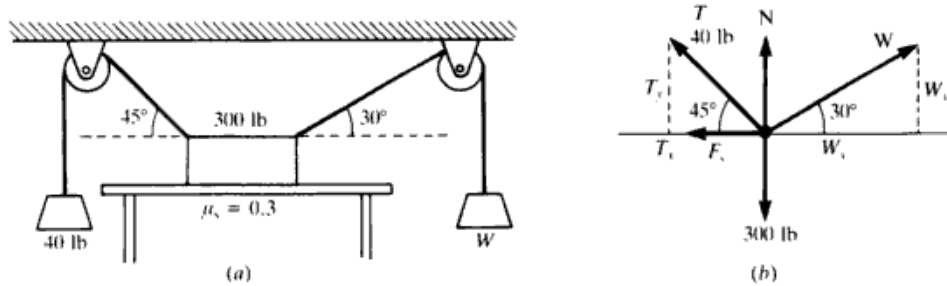

Fig. 2-26

From the force diagram, Fig. 2-26(b),

$$T_x = 40 \cos 45^\circ = 28.3 \text{ lb} \quad T_y = 40 \sin 45^\circ = 28.3 \text{ lb}$$

$$\sum F_y = 0 \quad T_y + W_y + N - 300 \text{ lb} = 0 \quad 28.3 \text{ lb} + W \sin 30^\circ + N = 300 \text{ lb} \quad N = 300 \text{ lb} - 28.3 \text{ lb} - 0.5W$$

$$\sum F_x = 0 \quad W_x - T_x - \mu_s N = 0 \quad \mu_s = 0.3 \quad W \cos 30^\circ - 28.3 \text{ lb} - 0.3N = 0$$

We substitute $N = 271.7 - 0.5W$ into the last equation to get

$$W \cos 30^\circ - 28.3 \text{ lb} - 0.3(271.7 - 0.5W) = 0.$$

Solving for W gives $W = 108 \text{ lb}$.

- 2.35 Assume that $W = 60 \text{ lb}$, $\theta = 43^\circ$, and $\mu_k = 0.3$ in Fig. 2-27(a). What push directed up the plane will move the block with constant speed (a) up the plane and (b) down the plane?

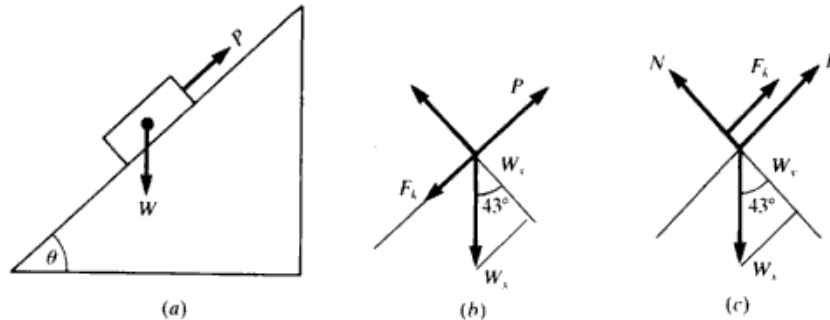

Fig. 2-27

The weight components are:

$$W_x = (60 \text{ lb}) \sin 43^\circ = 40.92 \text{ lb} \quad W_y = (60 \text{ lb}) \cos 43^\circ = 43.88 \text{ lb}$$

(a) Using Fig. 2-27(b),

$$\sum F_y = 0 \quad N - W_y = 0 \quad N = 43.88 \text{ lb}$$

$$F_k = \mu_k N = 0.3(43.88) \quad F_k = 13.16 \text{ lb}$$

$$\sum F_x = 0 \quad P - F_k - W_x = 0 \quad P = 13.16 + 40.92 \quad P = 54.1 \text{ lb}$$

(b) The push is now just enough to keep motion down plane to constant speed. From Fig. 2-27(c),

$$\sum F_x = 0 \quad P + F_k - W_x = 0 \quad P = 40.92 \text{ lb} - 13.16 \text{ lb} \quad P = 27.8 \text{ lb}$$

2.36 What horizontal push P is required to just hold a 200-N block on a 60° inclined plane if $\mu_s = 0.4$?

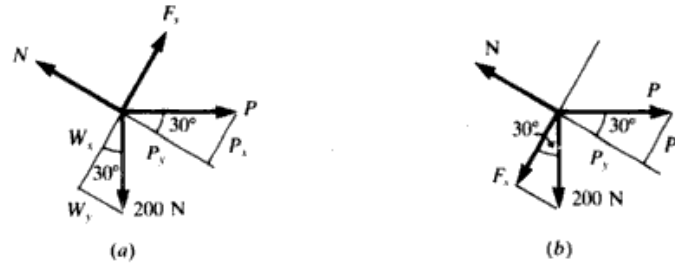

Fig. 2-28

Figure 2-28(a) is the free-body diagram.

$$W_x = 200 \cos 30^\circ = 173.2 \text{ N} \quad W_y = 200 \sin 30^\circ = 100 \text{ N} \quad F_s = \mu_s N$$

$$\sum F_y = 0 \quad N - P_y - W_y = 0 \quad P_y = P \cos 30^\circ \quad N = P \cos 30^\circ + W_y = 0.866P + 100 \text{ N}$$

$$\sum F_x = 0 \quad P_x + \mu_s N - W_x = 0 \quad \mu_s = 0.4$$

$$P \sin 30^\circ + 0.4(0.866P + 100 \text{ N}) - 173.2 \text{ N} = 0 \quad 0.5P + 0.346P + 40 \text{ N} - 173.2 \text{ N} = 0 \quad P = 157 \text{ N}$$

2.37 In Prob. 2.36, what horizontal push would just start the block moving up the plane?

Now Fig. 2-28(b) applies.

$$\sum F_y = 0 \quad N = 100 \text{ N} + 0.866P \quad \sum F_x = 0 \quad P \sin 30^\circ - W_x - \mu_s N = 0$$

$$0.5P - 173.2 \text{ N} - (0.4)(0.866P + 100 \text{ N}) = 0 \quad 0.5P - 173.2 \text{ N} - 0.346P - 40 \text{ N} = 0 \quad P = 1384 \text{ N}$$

2.38 In Fig. 2-29(a), the system is in equilibrium. (a) What is the maximum value that w can have if the friction force on the 40-N block cannot exceed 12.0 N? (b) What is the coefficient of static friction between the block and tabletop?

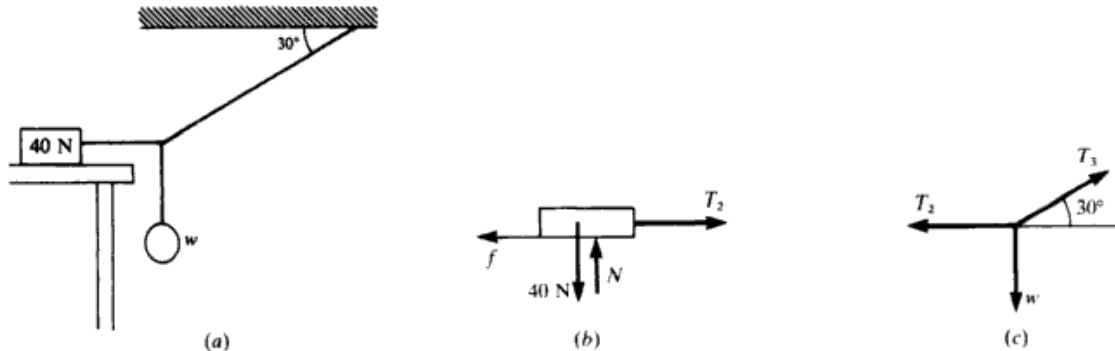

Fig. 2-29

(a) The free-body diagrams for the block and the knot are shown in Fig. 2-29(b) and (c).

$$f_{s(\max)} = 12.0 \text{ N} \quad \text{implies} \quad T_{2(\max)} = 12.0 \text{ N}$$

For the knot:

$$T_2 = T_3 \cos 30^\circ \quad w = T_3 \sin 30^\circ$$

Eliminating T_3 , we get $w = T_2 \tan 30^\circ = 0.577T_2$. Thus $w_{(\max)} = 0.577T_{2(\max)} = 6.92 \text{ N}$.

(b) $\mu_s = f_{s(\max)}/N = 12/40 = 0.30$.

2.39 The block of Fig. 2-29(a) is just on the verge of slipping. If $w = 8.0 \text{ N}$, what is the coefficient of static friction between the block and tabletop?

▮ At the verge of slipping, $f_s = f_{s(\max)}$ and the corresponding hanging weight is $w = 8.0 \text{ N}$. As in Prob. 2.38, $w = 0.577T_2$ and $T_2 = f_s$. Thus $f_{s(\max)} = w/0.577 = 8.0/0.577 = 13.9 \text{ N}$; $\mu_s = 13.9/40 = \underline{0.347}$.

2.40 Find the normal force acting on the block in each of the equilibrium situations shown in Fig. 2-30.

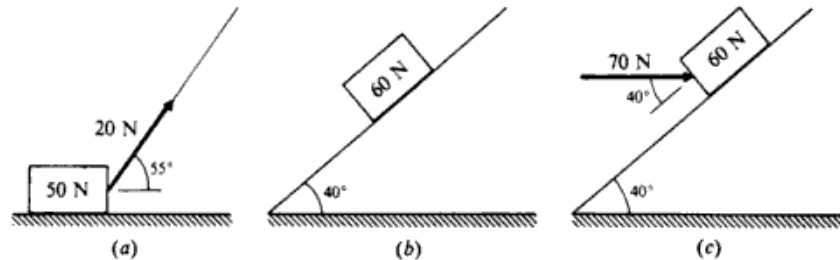

Fig. 2-30

▮ In each case friction is necessary for equilibrium. But friction does not enter in solving for N .

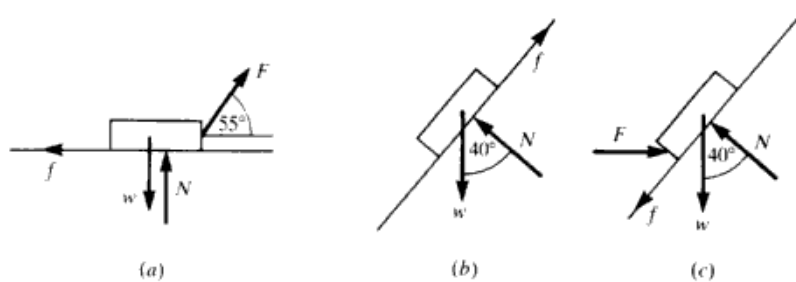

Fig. 2-31

(a) Free-body diagram is Fig. 2-31(a) ($F = 20 \text{ N}$, $w = 50 \text{ N}$).

$$\sum F_y = 0 \Rightarrow N - w + F \sin 55^\circ = 0 \quad N = 50 \text{ N} - (20 \text{ N})(0.819) = \underline{33.6 \text{ N}}$$

(b) Free-body diagram is Fig. 2-31(b) ($w = 60 \text{ N}$).

$$\sum F_y = 0 \Rightarrow N - w \cos 40^\circ = 0 \quad N = (60 \text{ N})(0.766) = \underline{46.0 \text{ N}}$$

(c) Free-body diagram is Fig. 2-31(c): ($F = 70 \text{ N}$, $w = 60 \text{ N}$).

$$\sum F_y = 0 \Rightarrow N - w \cos 40^\circ - F \sin 40^\circ = 0 \quad N = 60(0.766) + 70(0.643) = \underline{91.0 \text{ N}}$$

2.41 The block shown in Fig. 2-30(a) slides with constant speed under the action of the force shown. (a) How large is the retarding friction force? (b) What is the coefficient of kinetic friction between the block and the floor?

▮ Use Fig. 2-31(a) and Prob. 2.40(a).

(a) $\sum F_x = 0 \Rightarrow F \cos 55^\circ - f = 0 \quad (N_x = w_x = 0) \quad \text{or} \quad 20(0.573) = f = \underline{11.5 \text{ N}}$

(b) $\mu_k = \frac{f}{N} = \frac{11.5 \text{ N}}{34 \text{ N}} = \underline{0.34}$

2.42 The block shown in Fig. 2-30(b) slides at constant speed down the incline. (a) How large is the friction force that opposes its motion? (b) What is the coefficient of sliding (kinetic) friction between the block and plane?

▮ Use Fig. 2-31(b) and Prob. 2.40(b).

(a) $\sum F_x = 0 \Rightarrow f - w \sin 40^\circ = 0 \quad f = 60 \text{ N}(0.643) = \underline{38.6 \text{ N}}$

(b) $\mu_k = \frac{f}{N} = \frac{38.6 \text{ N}}{46 \text{ N}} = \underline{0.84}$

2.43 The block in Fig. 2-30(c) just begins to slide up the incline when the pushing force shown is increased to

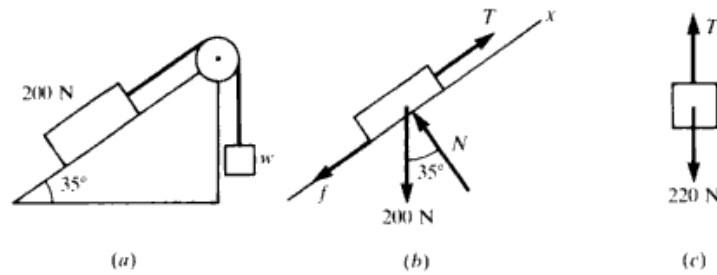

Fig. 2-32

70 N. (a) What is the critical static friction force on it? (b) What is the value of the coefficient of static friction?

■ Use Fig. 2-31(c) and Prob. 2.40(c).

(a) $\sum F_x = 0 \Rightarrow F \cos 40^\circ - w \sin 40^\circ - f = 0$, $F = 70 \text{ N}$ and block just starts to move $\Rightarrow f = f_{s(\max)} = 70(0.766) - 60(0.643) = 15.0 \text{ N}$

(b) $\mu_s = \frac{f_{s(\max)}}{N} = \frac{15.0 \text{ N}}{91 \text{ N}} = 0.17$

2.44 The system in Fig. 2-32(a) remains at rest when the hanging weight w is 220 N. What are the magnitude and direction of the friction force on the 200 N block? The pulley is frictionless.

■ Since the pulley is frictionless, the tension is the same throughout the cord. The free-body diagrams for the two blocks are as in Fig. 2-32(b) and (c). In principle the frictional force f could be either down the incline or up the incline depending on the details of the problem. In this case we can quickly assert that it is down the incline with the following reasoning: $T = 220 \text{ N}$. Opposing T along the incline is the component of the 200-N weight down the incline. This is surely less than the full 200 N and thus is insufficient to balance T . Therefore the help of friction down the incline is necessary. To obtain f we solve

$$\sum F_x = 0 \quad (\text{along incline}) \quad T - 200 \sin 35^\circ - f = 0 \Rightarrow f = 220 - 200(0.574) = 105 \text{ N}$$

(Note that for this problem the normal force, N , does not enter the calculation.)

CHAPTER 3

Kinematics in One Dimension

3.1 DIMENSIONS AND UNITS; CONSTANT-ACCELERATION PROBLEMS

- 3.1 A car's odometer reads 22 687 km at the start of a trip and 22 791 km at the end. The trip took 4 h. What was the car's average speed in kilometers per hour? In meters per second?

$$\text{Average speed} = \frac{\text{distance traveled}}{\text{time taken}} = \frac{(22\,791 - 22\,687) \text{ km}}{4 \text{ h}} = \underline{26 \text{ km/h}}$$

$$\text{To convert; Average speed} = 26 \frac{\text{km} \times (1000 \text{ m/km})}{\text{h} \times (3600 \text{ s/h})} = \underline{7.2 \text{ m/s}}$$

- 3.2 An auto travels at a rate of 25 km/h for 4 min, then at 50 km/h for 8 min, and finally at 20 km/h for 2 min. Find (a) the total distance covered in kilometers and (b) the average speed for the complete trip in meters per second.

(a) Distance traveled = $d_1 + d_2 + d_3$, where

$$d_1 = \left(25 \frac{\text{km}}{\text{h}}\right) \left(4 \frac{\text{min}}{60}\right) \left(\frac{1 \text{ h}}{60 \text{ min}}\right) = 1\frac{2}{3} \text{ km} \quad d_2 = \left(50 \frac{\text{km}}{\text{h}}\right) \left(8 \frac{\text{min}}{60}\right) \left(\frac{1 \text{ h}}{60 \text{ min}}\right) = 6\frac{2}{3} \text{ km}$$

$$d_3 = \left(20 \frac{\text{km}}{\text{h}}\right) \left(2 \frac{\text{min}}{60}\right) \left(\frac{1 \text{ h}}{60 \text{ min}}\right) = \frac{2}{3} \text{ km}$$

Thus $d_1 + d_2 + d_3 = \underline{9 \text{ km}}$.

$$(b) \text{ Average speed} = \frac{d_1 + d_2 + d_3}{\text{total time}} = \frac{9 \text{ km} \times 1000 \text{ m/km}}{(14 \text{ min} \times 60 \text{ s/min})} = \underline{10.7 \text{ m/s}}$$

- 3.3 A runner travels 1.5 laps around a circular track in a time of 50 s. The diameter of the track is 40 m and its circumference is 126 m. Find (a) the average speed of the runner and (b) the magnitude of the runner's average velocity.

$$(a) \text{ Average speed} = \frac{\text{distance}}{\text{time}} = \frac{(1.5 \text{ laps})}{50 \text{ s}} (126 \text{ m/lap}) = \underline{3.78 \text{ m/s}}$$

(b) Average velocity is a vector. It is the displacement vector for the time lapse of interest divided by the time lapse—in this case, 50 s. Since $1\frac{1}{2}$ laps have taken place, the displacement points from the starting point on the track to a point on the track $\frac{1}{2}$ lap away, which is of course directly across a diameter of the track. The magnitude of the average velocity is therefore the magnitude of the displacement divided by the time lapse. Thus magnitude of average velocity = $40 \text{ m}/50 \text{ s} = \underline{0.80 \text{ m/s}}$.

- 3.4 Use dimensional analysis to determine which of the following equations is certainly wrong:

$$\lambda = vt \quad F = \frac{m}{a} \quad F = \frac{mv}{t} \quad h = \frac{v^2}{2g} \quad v = (2gh)^{1/2}$$

where λ and h are lengths and $[F] = [MLT^{-2}]$. The other symbols have their usual meaning.

(a) $[vt] = [LT^{-1}][T] = [L]$, but $[\lambda] = [L]$, so equation $\lambda = vt$ can be correct. $[m/a] = [M][T^2L^{-1}] = [MT^2L^{-1}]$, but $[F] = [MLT^{-2}]$; hence $F = m/a$ is incorrect. $[mv/t] = [M][LT^{-1}][T^{-1}] = [MLT^{-2}]$ and $F = mv/t$ is dimensionally correct. $[v^2/2g] = [(L^2/T^2)/(L/T^2)] = [L]$; and since $[h] = [L]$, $h = v^2/2g$ is dimensionally correct. Since $[v] = [LT^{-1}]$, $[(2gh)^{1/2}] = [(L^{1/2}T^{-1})L^{1/2}] = [LT^{-1}]$, $v = (2gh)^{1/2}$ is also dimensionally correct. We note that pure numbers are dimensionless.

- 3.5 If s is distance and t is time, what must be the dimensions of C_1 , C_2 , C_3 , and C_4 in each of the following equations?

$$s = C_1 t \quad s = \frac{1}{2} C_2 t^2 \quad s = C_3 \sin C_4 t$$

(Hint: The argument of any trigonometric function must be dimensionless.)

▮ The dimension of s is $[L]$, so all expressions on the right-hand sides of the equations must also have the dimensions of length. $[C_1] = [L/T]$, since $[C_1 t]$ are then $[(L/T)T] = L$. $[C_2] = [LT^{-2}]$, $[C_3] = [L]$ because the sine is dimensionless, and since the argument of a trigonometric function has no units, $[C_4] = [T^{-1}]$.

- 3.6 The speed v of a wave on a string depends on the tension F in the string and the mass per unit length m/ℓ of the string. If it is known that $[F] = [ML][T]^{-2}$, find the constants a and b in the following equation for the speed of a wave on a string: $v = (\text{constant})F^a(m/\ell)^b$.

▮ It is given that $[v] = [F]^a[m/\ell]^b$. After inserting into this expression $[v]$ and $[F]$, we have, recalling M^0 means no mass units involved, $[M^0L^1T^{-1}] = [MLT^{-2}]^a[ML^{-1}]^b = [M]^{a+b}[L]^{a-b}[T^{-2}]^a$. A fundamental dimension must appear to the same power on both sides of an equation; hence, $a + b = 0$, $a - b = 1$, and $-2a = -1$. From this $a = \frac{1}{2}$ and $b = -\frac{1}{2}$.

- 3.7 The frequency of vibration f of a mass m at the end of a spring that has a stiffness constant k is related to m and k by a relation of the form $f = (\text{constant})m^a k^b$. Use dimensional analysis to find a and b . It is known that $[f] = [T]^{-1}$ and $[k] = [M][T]^{-2}$.

▮ As in Prob. 3.6,

$$f \propto m^a k^b \Rightarrow [M^0T^{-1}] = [M^a][M^bT^{-2b}] = [M^{a+b}T^{-2b}]$$

so

$$a + b = 0 \quad \text{and} \quad -2b = -1 \quad \text{or} \quad b = -a = \frac{1}{2}$$

- 3.8 A body with initial velocity 8 m/s moves along a straight line with constant acceleration and travels 640 m in 40 s. For the 40 s interval, find (a) the average velocity, (b) the final velocity, and (c) the acceleration.

▮ Assume $x = 0$ at $t = 0$.

(a) Average velocity = $\frac{\text{displacement}}{\text{time elapsed}} = \frac{640 \text{ m}}{40 \text{ s}} = 16 \text{ m/s}$

(b, c) $v_f = v_0 + at$. We know $v_0 = 8 \text{ m/s}$ and $t = 40 \text{ s}$, but we don't know a . However,

$$x = v_0 t + \frac{1}{2}at^2 \quad \text{or} \quad 640 \text{ m} = (8 \text{ m/s})(40 \text{ s}) + \frac{1}{2}a(40 \text{ s})^2$$

and solving we have

$$a = \frac{2(640 - 320) \text{ m}}{1600 \text{ s}^2} = \underline{0.40 \text{ m/s}^2}$$

Substituting into our velocity formula $v_f = 8 \text{ m/s} + (0.40 \text{ m/s}^2)(40 \text{ s}) = \underline{24 \text{ m/s}}$.

- 3.9 A truck starts from rest and moves with a constant acceleration of 5 m/s^2 . Find its speed and the distance traveled after 4 s has elapsed.

▮ $v_f = v_0 + at$, $v_0 = 0$, $a = 5 \text{ m/s}^2$, $t = 4 \text{ s}$

$$v_f = 0 + (5 \text{ m/s}^2)(4 \text{ s}) = \underline{20 \text{ m/s}}$$

To get distance, which in this case is the same as the magnitude of the displacement, we have

$$x = v_0 t + \frac{1}{2}at^2 = 0 + \frac{1}{2}(5 \text{ m/s}^2)(4 \text{ s})^2 = \underline{40 \text{ m}}$$

- 3.10 A box slides down an incline with uniform acceleration. It starts from rest and attains a speed of 2.7 m/s in 3 s. Find (a) the acceleration and (b) the distance moved in the first 6 s.

▮ Let x , v represent the displacement and velocity down the incline, respectively. Then, (a) $v_f = v_0 + at$ and we are given $v_0 = 0$, $v_f = 2.7 \text{ m/s}$, $t = 3.0 \text{ s}$; thus $2.7 \text{ m/s} = 0 + a(3.0 \text{ s})$, or $a = \underline{0.90 \text{ m/s}^2}$. Now we are interested in time $t = 6.0 \text{ s}$. So (b) $x = v_0 t + \frac{1}{2}at^2 = 0 + \frac{1}{2}(0.90 \text{ m/s}^2)(6.0 \text{ s})^2 = \underline{16.2 \text{ m}}$.

- 3.11 A car starts from rest and coasts down a hill with a constant acceleration. If it goes 90 m in 8 s, find (a) the acceleration and (b) the velocity after 8 s.

▮ (a) $s = \frac{1}{2}at^2$ (since $v_0 = 0$) $90 = \frac{1}{2}a(8)^2$ $a = \frac{180}{64} = \underline{2.8 \text{ m/s}^2}$

(b) $v = at = 2.8 \times 8 = \underline{22.4 \text{ m/s}}$

38 □ CHAPTER 3

- 3.12** A car is accelerating uniformly as it passes two checkpoints that are 30 m apart. The time taken between checkpoints is 4.0 s and the car's speed at the first checkpoint is 5.0 m/s. Find the car's acceleration and its speed at the second checkpoint.

▮ Calling the first checkpoint the initial position and the second the final position, we have, $v_0 = 5.0$ m/s, $x = 30$ m, $t = 4.0$ s. To find a we use the displacement equation

$$x = v_0 t + \frac{1}{2} a t^2 \quad \text{or} \quad 30 \text{ m} = (5.0 \text{ m/s})(4.0 \text{ s}) + \frac{1}{2} a (4.0 \text{ s})^2 \quad \text{or} \quad a = \underline{1.25 \text{ m/s}^2}$$

Then $v_f = v_0 + at$ yields $v_f = 5.0 \text{ m/s} + (1.25 \text{ m/s}^2)(4.0 \text{ s}) = \underline{10 \text{ m/s}}$.

- 3.13** An auto's velocity increases uniformly from 6.0 m/s to 20 m/s while covering 70 m. Find the acceleration and the time taken.

▮ We are given $v_f = 20$ m/s and $v_0 = 6.0$ m/s and the associated displacement is 70 m. Since the elapsed time t is not given, we find a using $v_f^2 = v_0^2 + 2ax$, or $(20 \text{ m/s})^2 = (6.0 \text{ m/s})^2 + 2a(70 \text{ m})$. Thus $a = \underline{2.6 \text{ m/s}^2}$. Now t follows immediately from

$$v_f = v_0 + at \quad \text{or} \quad 20 \text{ m/s} = 6.0 \text{ m/s} + (2.6 \text{ m/s}^2)t \quad \text{and} \quad t = \underline{5.4 \text{ s}}$$

- 3.14** A plane starts from rest and accelerates along the ground before takeoff. It moves 600 m in 12 s. Find (a) the acceleration, (b) speed at the end of 12 s, (c) distance moved during the twelfth second.

▮ We are given $v_0 = 0$, $x = 600$ m, $t = 12$ s.

(a) $x = v_0 t + \frac{1}{2} a t^2$, or $600 \text{ m} = 0 + \frac{1}{2} a (12 \text{ s})^2$. So $a = \underline{8.33 \text{ m/s}^2}$.

(b) $v_f = v_0 + at$, or $v_f = 0 + (8.33 \text{ m/s}^2)(12 \text{ s})$ and $v_f = \underline{100 \text{ m/s}}$.

(c) Remembering that the first second is between $t = 0$ and $t = 1$ s, we realize that the twelfth second is between $t = 11$ and $t = 12$ s. Since we already know $x(t = 12 \text{ s})$, we solve for $x(t = 11 \text{ s})$:

$$x = v_0 t + \frac{1}{2} a t^2 \quad \text{or} \quad x = 0 + \frac{1}{2} (8.33 \text{ m/s}^2)(11 \text{ s})^2 = 504 \text{ m}$$

Our answer is then $\Delta x(\text{twelfth s}) = x(t = 12 \text{ s}) - x(t = 11 \text{ s}) = \underline{96 \text{ m}}$.

- 3.15** A train running at 30 m/s is slowed uniformly to a stop in 44 s. Find the acceleration and the stopping distance.

▮ Here $v_0 = 30$ m/s and $v_f = 0$ at $t = 44$ s. $v_f = v_0 + at$ yields $0 = 30 \text{ m/s} + a(44 \text{ s})$, or $a = \underline{-0.68 \text{ m/s}^2}$. $x = v_0 t + \frac{1}{2} a t^2 = (30 \text{ m/s})(44 \text{ s}) + \frac{1}{2} (-0.68 \text{ m/s}^2)(44 \text{ s})^2 = \underline{662 \text{ m}}$.

- 3.16** An object moving at 13 m/s slows uniformly at the rate of 2.0 m/s each second for a time of 6 s. Determine (a) its final speed, (b) its average speed during the 6 s, and (c) the distance moved in the 6 s.

▮ Slowing "at the rate of 2.0 m/s each second" means $a = -2.0 \text{ m/s}^2$. We are given $v_0 = 13$ m/s and $t = 6.0$.

(a) Then $v_f = v_0 + at = 13 \text{ m/s} + (-2.0 \text{ m/s}^2)(6.0 \text{ s}) = \underline{1.0 \text{ m/s}}$. Because instantaneous speed is the magnitude of instantaneous velocity, our answer is $\underline{1.0 \text{ m/s}}$.

(b, c) Average speed = distance/time. The distance will be the same as the magnitude of the displacement as long as the object does not backtrack, i.e., reverse direction. In our case the velocity at the end of 6 s is still positive, so there indeed has been no backtracking. For displacement, $x = v_0 t + \frac{1}{2} a t^2 = (13 \text{ m/s})(6.0 \text{ s}) + \frac{1}{2} (-2.0 \text{ m/s}^2)(6.0 \text{ s})^2 = \underline{42 \text{ m}}$ [which incidentally solves part (c)]. Average speed = $42 \text{ m}/6.0 \text{ s} = \underline{7.0 \text{ m/s}}$.

- 3.17** A rocket-propelled car starts from rest at $x = 0$ and moves in the + direction of X with constant acceleration $a = 5 \text{ m/s}^2$ for 8 s until the fuel is exhausted. It then continues with constant velocity. What distance does the car cover in 12 s?

▮ The distance from x_0 at the moment fuel is exhausted is $x_1 = (0)(8) + \frac{1}{2} (5)(8)^2 = \underline{160 \text{ m}}$, and at this point $v = (2ax_1)^{1/2} = 40 \text{ m/s}$. Hence the distance covered in 12 s is $x_2 = x_1 + v(12 - 8) = 160 + (40)(4) = \underline{320 \text{ m}}$.

- 3.18** The particle shown in Fig. 3-1 moves along X with a constant acceleration of -4 m/s^2 . As it passes the origin, moving in the + direction of X , its velocity is 20 m/s. In this problem, time t is measured from the moment the particle is first at the origin. (a) At what distance x' and time t' does $v = 0$? (b) At what time is the particle at $x = 15$ m, and what is its velocity at this point? (c) What is the velocity of the particle at $x = +25$ m? at $x = -25$ m? Try finding the velocity of the particle at $x = 55$ m.

▮ (a) Applying $v = v_0 + at$, $0 = 20 + (-4)t'$, or $t' = 5$ s. Then $x' = v_0t' + \frac{1}{2}at'^2 = (20)(5) + \frac{1}{2}(-4)(5)^2 = 50$ m. Or, from $v^2 = v_0^2 + 2ax$:

$$0 = (20)^2 + 2(-4)x' \quad \text{or} \quad x' = 50 \text{ m.}$$

(b) $15 = 20t + \frac{1}{2}(-4)t^2$ or $2t^2 - 20t + 15 = 0$

Solving this quadratic,

$$t = \frac{20 \pm \sqrt{(20)^2 - 4(2)(15)}}{4} = \frac{1}{4}(20 \pm 16.7)$$

Thus $t_1 = 0.82$ s, $t_2 = 9.17$ s, where t_1 is the time from the origin to $x = 15$ m and t_2 is the time to go from O out beyond $x = 15$ m and return to that point. At $x = 15$ m,

$$v_1 = 20 - 4(0.82) = +16.7 \text{ m/s} \quad v_2 = 20 - 4(9.17) = -16.7 \text{ m/s}$$

Observe that the speeds are equal.

(c) At $x = 25$ m, $v^2 = (20)^2 + 2(-4)(25)$, or $v = \pm 14.1$ m/s; and at $x = -25$ m, $v^2 = 20^2 + 2(-4)(-25)$, or $v = -24.5$ m/s. (Why has the root $v = +24.5$ m/s been discarded?)

Assuming that $x = 55$ m, $v^2 = 20^2 + 2(-4)(55)$, from which $v = \pm\sqrt{-40}$. The imaginary value of v indicates that x never reaches 55 m, as expected from the result of part (a).

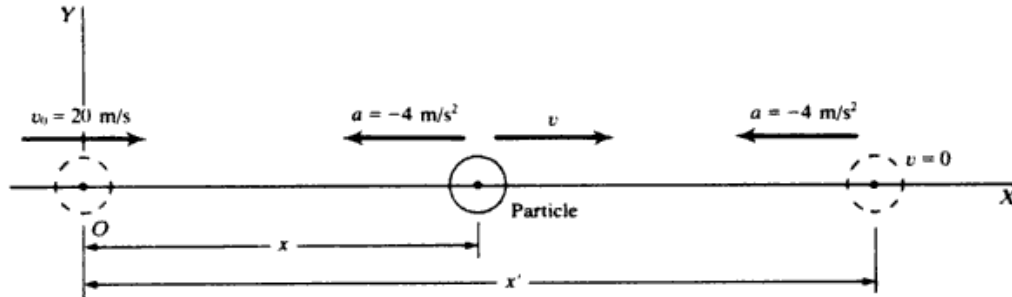

Fig. 3-1

- 3.19 A body falls freely from rest. Find (a) its acceleration, (b) the distance it falls in 3 s, (c) its speed after falling 70 m, (d) the time required to reach a speed of 25 m/s, (e) the time taken to fall 300 m.

▮ (a) Choose y downward as positive. Then $a = g = 9.8 \text{ m/s}^2$. (b) For $t = 3.0$ s, $y = v_0t + \frac{1}{2}at^2 = 0 + \frac{1}{2}(9.8 \text{ m/s}^2)(3.0 \text{ s})^2 = 44$ m. (c) Letting $y = 70$ m, we have

$$v_f^2 = v_0^2 + 2ay = 0 + 2(9.8 \text{ m/s}^2)(70 \text{ m}) = 1372 \text{ m}^2/\text{s}^2 \quad \text{or} \quad v_f = 37 \text{ m/s}$$

(d) Letting v_f now equal 25 m/s, we have

$$v_f = v_0 + at \quad \text{yields} \quad 25 \text{ m/s} = 0 + (9.8 \text{ m/s}^2)t \quad \text{or} \quad t = 2.55 \text{ s}$$

(e) Now we let $y = 300$ m and we have

$$y = v_0t + \frac{1}{2}at^2 \quad \text{yields} \quad 300 \text{ m} = 0 + \frac{1}{2}(9.8 \text{ m/s}^2)t^2 \quad \text{or} \quad t = 7.8 \text{ s}$$

- 3.20 A ball dropped from a bridge strikes the water in 5 s. Calculate (a) the speed with which it strikes and (b) the height of the bridge.

▮ Choose y downward as positive. Then $a = g = 9.8 \text{ m/s}^2$. We are given $v_0 = 0$, and $t = 5$ s to strike the water. Let $v = v_f$.

(a) $v = v_0 + at = 0 + (9.8 \text{ m/s}^2)(5 \text{ s}) = 49 \text{ m/s}$ (b) $y = v_0t + \frac{1}{2}at^2 = 0 + \frac{1}{2}(9.8 \text{ m/s}^2)(5 \text{ s})^2 = 123 \text{ m}$

- 3.21 A ball is thrown vertically downward from the edge of a high cliff with an initial velocity of 25 ft/s. (a) How fast is it moving after 1.5 s? (b) How far has it moved after 1.5 s?

▮ (a) $v = v_0 + at = 25 + 32(1.5)$ or $v = 73 \text{ ft/s}$ (where $a = g = 32 \text{ ft/s}^2$)

(b) For constant acceleration $v_{\text{avg}} = \frac{1}{2}(v + v_0) = \frac{1}{2}(73 + 25) = 49 \text{ ft/s}$

$$s = v_{\text{avg}}t = 49(1.5) = 73.5 \text{ ft} \quad \text{or} \quad s = v_0t + \frac{1}{2}at^2 = 25(1.5) + \frac{1}{2}(32)(1.5)^2 = 37.5 + 36 = 73.5 \text{ ft}$$

- 3.22** A stone is thrown downward with initial speed 8 m/s from a height of 25 m. Find **(a)** the time it takes to reach the ground and **(b)** the speed with which it strikes.

| Choose downward positive. $a = g = 9.8 \text{ m/s}^2$. We are given $v_0 = 8 \text{ m/s}$.

(a) One might directly solve $y = v_0 t + \frac{1}{2} a t^2$, or $25 \text{ m} = (8 \text{ m/s})t + \frac{1}{2}(9.8 \text{ m/s}^2)t^2$ for t ; but it is easier first to find the final velocity:

(b) $v_f^2 = v_0^2 + 2ay = (8 \text{ m/s})^2 + 2(9.8 \text{ m/s})(25 \text{ m}) = 554 \text{ m}^2/\text{s}^2$, or $v_f = \underline{23.5 \text{ m/s}}$. Returning to **(a)**, $v_f = v_0 + at$ yields $23.5 \text{ m/s} = 8 \text{ m/s} + (9.8 \text{ m/s}^2)t$, or $t = \underline{1.58 \text{ s}}$.

- 3.23** A ball thrown vertically upward returns to its starting point in 4 s. Find its initial speed.

| Let us take up as positive. For the trip from beginning to end, $y = 0$, $a = -9.8 \text{ m/s}^2$, $t = 4 \text{ s}$. Note that the start and the endpoint for the trip are the same, so the displacement is zero. Use $y = v_0 t + \frac{1}{2} a t^2$ to find $0 = v_0(4 \text{ s}) + \frac{1}{2}(-9.8 \text{ m/s}^2)(4 \text{ s})^2$, from which $v_0 = \underline{19.6 \text{ m/s}}$.

- 3.24** An anti-aircraft shell is fired vertically upward with an initial velocity of 500 m/s. Neglecting friction, compute **(a)** the maximum height it can reach, **(b)** the time taken to reach that height, and **(c)** the instantaneous velocity at the end of 60 s. **(d)** When will its height be 10 km?

| Take up as positive. At the highest point, the velocity of the shell will be zero.

(a) $v_f^2 = v_0^2 + 2ay$ or $0 = (500 \text{ m/s})^2 + 2(-9.8 \text{ m/s}^2)y$ or $y = \underline{12.8 \text{ km}}$

(b) $v_f = v_0 + at$ or $0 = 500 \text{ m/s} + (-9.8 \text{ m/s}^2)t$ or $t = \underline{51 \text{ s}}$

(c) $v_f = v_0 + at$ or $v_f = 500 \text{ m/s} + (-9.8)(60 \text{ s}) = \underline{-88 \text{ m/s}}$

Because v_f is negative, and because we are taking up as positive, the velocity is directed downward. The shell is on its way down at $t = 60 \text{ s}$.

(d) $y = v_0 t + \frac{1}{2} a t^2$ or $10\,000 \text{ m} = (500 \text{ m/s})t + \frac{1}{2}(-9.8 \text{ m/s}^2)t^2$ or $4.9t^2 - 500t + 10\,000 = 0$

The quadratic formula,

$$x = \frac{-b \pm \sqrt{b^2 - 4ac}}{2a}$$

gives $t = \underline{27 \text{ s}}$ and $\underline{75 \text{ s}}$. At $t = 27 \text{ s}$, the shell is at 10 km and ascending; at $t = 75 \text{ s}$, it is at the same height but descending.

- 3.25** A ballast bag is dropped from a balloon that is 300 m above the ground and rising at 13 m/s. For the bag, find **(a)** the maximum height reached, **(b)** its position and velocity 5 s after being released, and **(c)** the time before it hits the ground.

| The initial velocity of the bag when released is the same as that of the balloon, 13 m/s upward. Let us choose up as positive and take $y = 0$ at the point of release.

(a) At the highest point, $v_f = 0$. From $v_f^2 = v_0^2 + 2ay$, $0 = (13 \text{ m/s})^2 + 2(-9.8 \text{ m/s}^2)y$, or $y = \underline{8.6 \text{ m}}$. The maximum height is $300 + 8.6 = \underline{308.6 \text{ m}}$. **(b)** Take the endpoint to be its position at $t = 5 \text{ s}$. Then, from $y = v_0 t + \frac{1}{2} a t^2$, $y = (13 \text{ m/s})(5 \text{ s}) + \frac{1}{2}(-9.8 \text{ m/s}^2)(5 \text{ s})^2 = -58 \text{ m}$. So its height is $300 - 58 = \underline{242 \text{ m}}$. Also, from $v_f = v_0 + at$, $v_f = 13 \text{ m/s} + (-9.8 \text{ m/s}^2)(5 \text{ s}) = \underline{-36 \text{ m/s}}$. It is moving downward at 36 m/s.

(c) Just before it hits the ground, the bag's displacement is -300 m . $y = v_0 t + \frac{1}{2} a t^2$ becomes $-300 \text{ m} = (13 \text{ m/s})t + \frac{1}{2}(-9.8 \text{ m/s}^2)t^2$, or $4.9t^2 - 13t - 300 = 0$. The quadratic formula gives $t = \underline{9.3 \text{ s}}$ (and -6.6 s , which is not physically meaningful).

- 3.26** A stone is thrown vertically upward with velocity 40 m/s at the edge of a cliff having a height of 110 m. Neglecting air resistance, compute the time required to strike the ground at the base of the cliff. With what velocity does it strike?

| Choose upward as positive. $a = -g = -9.8 \text{ m/s}^2$, $v_0 = 40 \text{ m/s}$, $y_{(\text{base of cliff})} = -110 \text{ m}$. First obtain the final velocity: $v^2 = v_0^2 + 2ay = 40^2 + 2(-9.8)(-110) = 3756 \text{ m}^2/\text{s}^2$, whence $v = \underline{-61.3 \text{ m/s}}$ (downward motion). Then, from $v = v_0 + at$,

$$-61.3 = 40 + (-9.8)t \quad \text{or} \quad t = \underline{10.3 \text{ s}}$$

- 3.27** The hammer of a pile driver strikes the pile with a speed of 25 ft/s. From what height above the top of the pile did it fall? Neglect friction forces.

| Downward is positive. We assume it falls from rest, so $v_0 = 0$, $v = 25 \text{ ft/s}$, $a = g = 32 \text{ ft/s}^2$. We need not

concern ourselves with the time of the fall t , since we can solve using

$$v^2 = v_0^2 + 2ay \quad \text{or} \quad (25 \text{ ft/s})^2 = 2(32 \text{ ft/s}^2)y$$

Then $y = \underline{9.8 \text{ ft}}$.

- 3.28** A baseball is thrown straight upward with a speed of 30 m/s. **(a)** How long will it rise? **(b)** How high will it rise? **(c)** How long after it leaves the hand will it return to the starting point? **(d)** When will its speed be 16 m/s?

| We choose upward as positive. $a = -g = -9.8 \text{ m/s}^2$, $v_0 = 30 \text{ m/s}$.

(a) At the highest point $v = 0$; so for time to reach highest point, $v = v_0 + at$ yields $0 = 30 \text{ m/s} + (-9.8 \text{ m/s}^2)t$, or $t = \underline{3.06 \text{ s}}$. **(b)** $y = v_0t + \frac{1}{2}at^2 = (30 \text{ m/s})(3.06 \text{ s}) + \frac{1}{2}(-9.8 \text{ m/s}^2)(3.06 \text{ s})^2 = \underline{46 \text{ m}}$, [or $v^2 = v_0^2 + 2ay$ yields $0 = (30 \text{ m/s})^2 + 2(-9.8 \text{ m/s}^2)y$, and $y = 46 \text{ m}$]. **(c)** Without calculation: Since the time up equals the time down, we double the time up to get 6.12 s for the round trip. With calculation: For the final displacement, we have $y = 0$, so

$$y = v_0t + \frac{1}{2}at^2 \quad \text{yields} \quad 0 = (30 \text{ m/s})t + \frac{1}{2}(-9.8 \text{ m/s}^2)t^2$$

This is a quadratic equation but easy to solve. One solution is $t = 0$, but this corresponds to $y = 0$ as it leaves the hand. The other solution is not 0, so we can divide out by t , leaving

$$0 = 30 \text{ m/s} - (4.9 \text{ m/s}^2)t \quad \text{or} \quad t = \underline{6.12 \text{ s}}$$

(d) Recalling that the speed is the magnitude of the velocity, we must consider the possible velocities: $v = \pm 16 \text{ m/s}$. $v = v_0 + at$ yields $\pm 16 \text{ m/s} = 30 \text{ m/s} + (-9.8 \text{ m/s}^2)t$; and solving for t ; $t_+ = \underline{1.43 \text{ s}}$, $t_- = \underline{4.7 \text{ s}}$.

- 3.29** The acceleration due to gravity at the surface of Mars is roughly 4 m/s^2 . If an astronaut on Mars were to toss a wrench upward with a speed of 10 m/s, find **(a)** how long it would rise; **(b)** how high it would go; **(c)** its speed at $t = 3 \text{ s}$; and **(d)** its displacement at $t = 3 \text{ s}$.

| Let us choose up as positive. Then a equals -4 m/s^2 , and v_0 equals $+10 \text{ m/s}$.

(a) By equation of motion $a = (v - v_0)/t$, we have

$$-4 \text{ m/s}^2 = \frac{0 - 10 \text{ m/s}}{t_{\text{rise}}} \quad t_{\text{rise}} = \underline{2.5 \text{ s}}$$

(b) By equation of motion $v^2 = v_0^2 + 2as$, we have

$$0^2 = (10)^2 + 2(-4)s_{\text{max}} \quad \text{and} \quad s_{\text{max}} = \underline{12.5 \text{ m}}$$

(c) By equation of motion $a = (v - v_0)/t$, we have

$$-4 = \frac{v_3 - 10}{3} \quad \text{and} \quad v_3 = \underline{-2 \text{ m/s}} \quad \text{or} \quad 2 \text{ m/s downward}$$

(d) $s = v_0t + \frac{1}{2}at^2$ and thus

$$s_3 = (10 \times 3) + \frac{1}{2}(-4)(9) = 30 - 18 = \underline{12 \text{ m}}$$

- 3.30** The acceleration due to gravity on the moon is 1.67 m/s^2 . If a person can throw a stone 12.0 m straight upward on the earth, how high should the person be able to throw a stone on the moon? Assume that the throwing speeds are the same in the two cases.

| On earth we can write $v_E^2 = 2g_E(12)$ while on the moon $v_M^2 = 2g_M h_M$. The throwing velocities are the same, so the second expression can be divided by the first to give $h_M = 12(g_E/g_M) = 12(9.80/1.67) = \underline{70 \text{ m}}$.

- 3.31** A proton in a uniform electric field moves along a straight line with constant acceleration. Starting from rest it attains a velocity of 1000 km/s in a distance of 1 cm. **(a)** What is its acceleration? **(b)** What time is required to reach the given velocity?

| **(a)** $v_0 = 0$, $v = 10^6 \text{ m/s}$ in $x = 10^{-2} \text{ m}$ of displacement. Then $v^2 = v_0^2 + 2ax$ yields $(10^6 \text{ m/s})^2 = 0 + 2a(10^{-2} \text{ m})$, or $a = \underline{5.0 \times 10^{13} \text{ m/s}^2}$. **(b)** $v = v_0 + at$ yields $10^6 \text{ m/s} = 0 + (5.0 \times 10^{13} \text{ m/s}^2)t$, or $t = \underline{2.0 \times 10^{-8} \text{ s}}$.

- 3.32** A bottle dropped from a balloon reaches the ground in 20 s. Determine the height of the balloon if **(a)** it was at rest in the air and **(b)** it was ascending with a speed of 50 m/s when the bottle was dropped.

▮ Choose upward as positive for both (a) and (b). $a = -g = -9.8 \text{ m/s}^2$.

(a) $v_0 = 0$. To find the height, let y be the displacement at time t (remember the $y = 0$ point is at the balloon) and we are given $t = 20 \text{ s}$. Then $y = v_0 t + \frac{1}{2} a t^2 = 0 + \frac{1}{2}(-9.8 \text{ m/s}^2)(20 \text{ s})^2 = -1960 \text{ m}$. The height is $|y| = 1960 \text{ m}$.

(b) Here the bottle initially has the velocity of the balloon so $v_0 = 50 \text{ m/s}$. Now, $y = v_0 t + \frac{1}{2} a t^2 = (50 \text{ m/s})(20 \text{ s}) + \frac{1}{2}(-9.8 \text{ m/s}^2)(20 \text{ s})^2 = -960 \text{ m}$. Again the height $= |y| = 960 \text{ m}$.

3.33 A sandbag ballast is dropped from a balloon that is ascending with a velocity of 40 ft/s. If the sandbag reaches the ground in 20 s, how high was the balloon when the bag was dropped? Neglect air resistance.

▮ Take downward as positive. Then $a = g = 32 \text{ ft/s}^2$ and $v_0 = -40 \text{ ft/s}$.

$$s = v_0 t + \frac{1}{2} a t^2 = -40(20) + \frac{1}{2}(32)(20)^2 = -800 + 6400 = 5600 \text{ ft}$$

The balloon was 5600 ft above the ground.

3.34 A stone is shot straight upward with a speed of 80 ft/s from a tower 224 ft high. Find the speed with which it strikes the ground.

▮ Choose upward as positive. $a = g = -32 \text{ ft/s}^2$, $v_0 = 80 \text{ ft/s}$. The presumption is that the stone just misses the edge of the tower on the way down and strikes the ground 224 ft below. We can avoid all reference to the time in the problem by setting $y = -224 \text{ ft}$ in the equation

$$v^2 = v_0^2 + 2ay = (80 \text{ ft/s})^2 + 2(-32 \text{ ft/s}^2)(-224 \text{ ft}) = 20\,736 \text{ ft}^2/\text{s}^2$$

And $v = \pm 144 \text{ ft/s}$, where the minus sign gives the physical solution. The speed is $|v| = 144 \text{ ft/s}$.

3.35 A nut comes loose from a bolt on the bottom of an elevator as the elevator is moving up the shaft at 3.0 m/s. The nut strikes the bottom of the shaft in 2 s. (a) How far from the bottom of the shaft was the elevator when the nut fell off? (b) How far above the bottom was the nut 0.25 s after it fell off?

▮ Here the nut initially has the velocity of the elevator, so choosing upward as positive, $v_0 = 3.0 \text{ m/s}$. Also $a = -g = -9.8 \text{ m/s}^2$.

(a) The time to hit bottom is 2.0 s, so $y = v_0 t + \frac{1}{2} a t^2 = (3.0 \text{ m/s})(2.0 \text{ s}) + \frac{1}{2}(-9.8 \text{ m/s}^2)(2.0 \text{ s})^2 = -13.6 \text{ m}$. The bottom of the shaft is 13.6 m below where the elevator was when the nut fell off.

(b) The new displacement y is for $t = 0.25 \text{ s}$, so $y = v_0 t + \frac{1}{2} a t^2 = (3.0 \text{ m/s})(0.25 \text{ s}) + \frac{1}{2}(-9.8 \text{ m/s}^2)(0.25 \text{ s})^2 = 0.44 \text{ m}$. Thus the nut is above its starting position. (This makes sense if we remember the initial velocity.) The height above the bottom is thus $0.4 + 13.6 = 14.0 \text{ m}$.

3.2 GRAPHICAL AND OTHER PROBLEMS

3.36 The graph of an object's motion (along a line) is shown in Fig. 3-2. Find the instantaneous velocity of the object at points A and B. What is the object's average velocity? Its acceleration?

▮ Because the velocity is given by the slope, $\Delta x / \Delta t$, of the tangent line, we take a tangent to the curve at point A. The tangent line is the curve itself in this case. For the triangle shown at A, we have

$$\frac{\Delta x}{\Delta t} = \frac{4 \text{ m}}{8 \text{ s}} = 0.50 \text{ m/s}$$

This is also the velocity at point B and at every other point on the straight-line graph. It follows that $a = 0$ and $\bar{v}_x = v_x = 0.50 \text{ m/s}$.

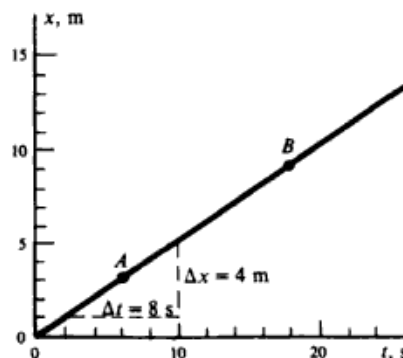

Fig. 3-2

3.37 Refer to Fig. 3-3. Find the instantaneous velocity at point *F* for the object whose motion the curve represents.

| The tangent at *F* is the dashed line *GH*. Taking triangle *GHI*, we have

$$\Delta t = 24 - 4 = 20 \text{ s} \quad \Delta x = 0 - 15 = -15 \text{ m}$$

Hence slope at *F* is
$$v_F = \frac{\Delta x}{\Delta t} = \frac{-15 \text{ m}}{20 \text{ s}} = -0.75 \text{ m/s}$$

The negative sign tells us that the object is moving in the $-x$ direction.

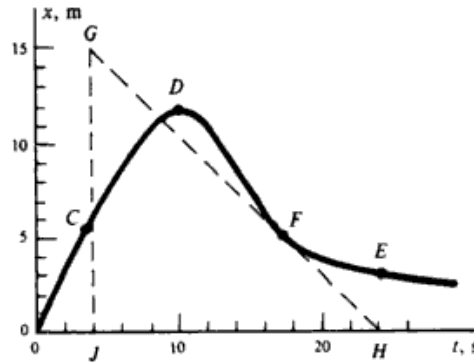

Fig. 3-3

3.38* Refer back to Fig. 3.3 for the motion of an object along the *x* axis. What is the instantaneous velocity of the object (a) at point *D*? (b) at point *C*? (c) at point *E*?

| (a) Point *d* is a maximum of the *x*-vs.-*t* curve. Therefore $v = dx/dt = 0$.

(b) Without the exact equation for *x* as function of *t* one cannot get a precise answer. The best we can do is to draw the tangent line at point *c* and get the slope in the same way as in Prob. 3.37. This yields the answer

$$v_C = \left. \frac{dx}{dt} \right|_C \approx 1.3 \text{ m/s}$$

(c) We proceed as in part (b), but here the tangent line has a negative slope and the answer should be

$$v_E = \left. \frac{dx}{dt} \right|_E \approx -0.13 \text{ m/s}$$

3.39 A girl walks along an east–west street, and a graph of her displacement from home is shown in Fig. 3-4. Find her average velocity for the whole time interval shown as well as her instantaneous velocity at points *A*, *B*, and *C*.

| The average velocity is zero, since the displacement vector is zero. The instantaneous velocities are just the slopes of the curve at each point. At *A* the velocity is $40/6 = 6.7 \text{ m/min}$ east. At *B* it is zero. At *C* it is $-65/5 = -13 \text{ m/min}$ east, or $+13 \text{ m/min}$ west.

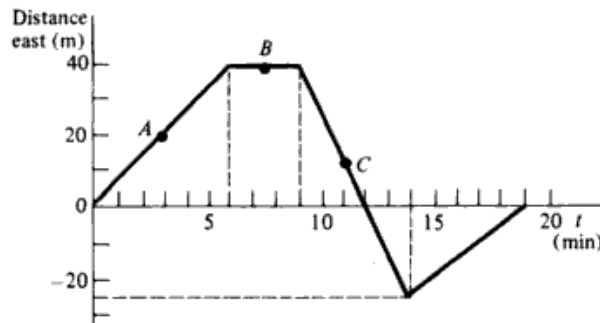

Fig. 3-4

3.40 Referring to Fig. 3-4, find (a) average velocity for the time interval $t = 7$ min to $t = 14$ min; the instantaneous velocity at (b) $t = 13.5$ min and (c) $t = 15$ min.

▮ (a) $\bar{v} = (-25 - 40)/(14 - 7) = -9.3$ m/min east; (b) the same as at point C, -13 m/min east; (c) the slope is $+25/(19 - 14) = 5.0$ m/min east. Note that negative velocity east means motion is west.

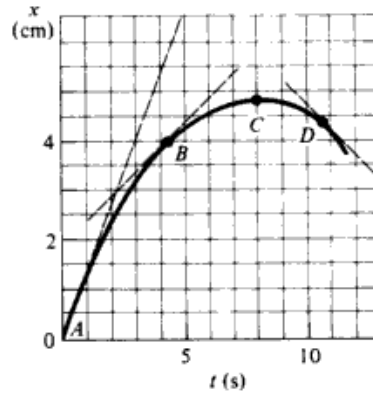

Fig. 3-5

3.41 The graph of a particle's motion along the x axis is given in Fig. 3-5. Estimate the (a) average velocity for the interval from A to C; instantaneous velocity at (b) D and at (c) A.

▮ (a) $\bar{v} = (4.8 - 0)/(8.0 - 0) = 0.60$ cm/s. From the slope at each point (b) $v = -0.48$ and (c) 1.3 cm/s.

3.42 Figure 3-6 shows the velocity of a particle as it moves along the x axis. Find its acceleration at (a) A and at (b) C.

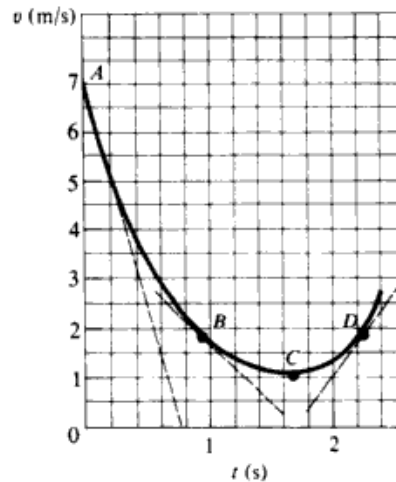

Fig. 3-6

▮ The acceleration at any time is the slope of the v -vs.- t curve. (a) At A the slope is, from where the tangent line through A cuts the coordinate axes, $a = -7.0/0.73 = -9.6$ m/s². (b) The slope and therefore a is zero.

3.43 For the motion described by Fig. 3-6, find the acceleration at (a) B and at (b) D.

▮ Taking slopes at B and D we find that the acceleration = (a) -2.4 and (b) 3.2 m/s².

3.44 A ball is thrown vertically upward with a velocity of 20 m/s from the top of a tower having a height of 50 m, Fig. 3-7. On its return it misses the tower and finally strikes the ground. (a) What time t_1 elapses from the instant the ball was thrown until it passes the edge of the tower? What velocity v_1 does it have at this time? (b) What total time t_2 is required for the ball to reach the ground? With what velocity v_2 does it strike the ground?

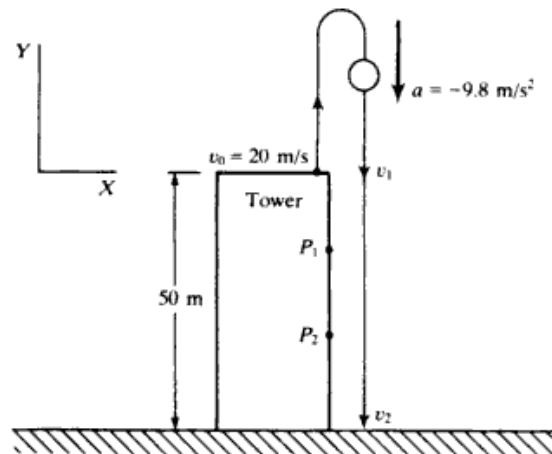

Fig. 3-7

▮ (a) For the coordinate system shown in Fig. 3-7, $y = v_0t + \frac{1}{2}at^2$. But at the edge of the roof $y = 0$, and thus $0 = 20t_1 + \frac{1}{2}(-9.8)t_1^2$, from which $t_1 = 0$, indicating the instant at which the ball is released, and also $t_1 = 4.08$ s, which is the time to go up and return to the edge. Then, from $v = v_0 + at$, $v_1 = 20 + (-9.8)(4.08) = -20$ m/s, which is the negative of the initial velocity.

(b) $-50 = 20t_2 + \frac{1}{2}(-9.8)t_2^2$ or $t_2 = 5.8$ s $v_2 = 20 + (-9.8)(5.8) = -37$ m/s

- 3.45 Refer to Prob. 3.44 and Fig. 3-7. (a) What is the maximum height above ground reached by the ball? (b) Points P_1 and P_2 are 15 and 30 m, respectively, below the top of the tower. What time interval is required for the ball to travel from P_1 to P_2 ? (c) It is desired that after passing the edge, the ball will reach the ground in 3 s. With what velocity must it be thrown upward from the roof?

▮ (a) Maximum height above ground: $h = y_{\max} + 50$. From $v_0^2 + 2ay_{\max} = 0$,

$$y_{\max} = \frac{-(20)^2}{-2(9.8)} = 20.4 \text{ m}$$

Thus, $h = 70.4$ m.

(b) If t_1 and t_2 are the times to reach P_1 and P_2 , respectively, $-15 = 20t_1 - 4.9t_1^2$ and $-30 = 20t_2 - 4.9t_2^2$. Solving, $t_1 = 4.723$ s, $t_2 = 5.248$ s, and the time from P_1 to P_2 is $t_2 - t_1 = 0.525$ s.

(c) If v_0 is the desired initial velocity, then $-v_0$ is the velocity upon passing the edge. Then, applying $y = v_0t + \frac{1}{2}at^2$ to the trip down the tower, we find $-50 = (-v_0)(3) - 4.9(3)^2$, or $v_0 = 1.96$ m/s.

- 3.46 A man runs at a speed of 4.0 m/s to overtake a standing bus. When he is 6.0 m behind the door (at $t = 0$), the bus moves forward and continues with a constant acceleration of 1.2 m/s². (a) How long does it take for the man to gain the door? (b) If in the beginning he is 10.0 m from the door, will he (running at the same speed) ever catch up?

▮ At $t = 0$ let the man's position be the origin, $x_{m0} = 0$. The bus door is then at $x_{b0} = 6.0$ m. The equations of motion for the man and the bus are

$$x_m = x_{m0} + v_{m0}t + \frac{1}{2}a_mt^2 \quad x_b = x_{b0} + v_{b0}t + \frac{1}{2}a_bt^2$$

Now $v_{m0} = 4.0$ m/s $v_{b0} = 0$ $a_m = 0$ $a_b = 1.2$ m/s²

Thus $x_m = 4.0t$ $x_b = 6.0 + 0.6t^2$

When the man catches the bus, $x_m = x_b$, or $4.0t = 6.0 + 0.6t^2$.

This can be reexpressed as $3t^2 - 20t + 30 = 0$. Solving by the quadratic formula,

$$t = \frac{20 \pm \sqrt{400 - 360}}{6} = \frac{10 \pm \sqrt{10}}{3} = 2.3 \text{ s}, 4.4 \text{ s}$$

Note that there are two positive time solutions. This can be understood as follows. The first time, $t_1 = 2.3$ s, corresponds to his first reaching the door. This is the real answer to the problem. However, the equations we have solved "don't know" he will stop running and board the bus; the equations have him continuing running at constant speed. He thus goes on past the bus; but since the bus is accelerating, it eventually builds up a larger velocity than the man and will catch up with him, $t_2 = 4.4$ s.

(b) If the initial position of the bus is 10.0 m, then $x_m = x_b$ yields $3t^2 - 20t + 50 = 0$, which has only complex roots. Thus no real time exists at which the man catches up.

- 3.47 A ball is thrown straight upward with a speed v from a height h above the ground. Show that the time taken for the ball to strike the ground is

$$\frac{v}{g} \left(1 + \sqrt{1 + \frac{2hg}{v^2}} \right)$$

▮ Assuming the positive direction to be upward, the uniform acceleration equation is $-h = vt - gt^2/2$; this can be rewritten in the form $t^2 - 2vt/g - 2h/g = 0$. Solving for t using the quadratic formula gives the desired answer. Since we seek positive values for time, the + root must be chosen.

- 3.48 A ball is dropped from the top of a building. The ball takes 0.5 s to fall past the 3-m length of a window some distance from the top of the building. (a) How fast was the ball going as it passed the top of the window? (b) How far is the top of the window from the point at which the ball was dropped?

▮ The velocities v_T at the top and v_B at the bottom of the window are related by the following equations: $\bar{v} = (v_T + v_B)/2 = 3/0.5 = 6$, so $v_T + v_B = 12$, and $v_B = v_T + g(0.5)$, so $v_B - v_T = 4.9$. Eliminating v_B between these two expressions yields $v_T = 3.55 \text{ m/s}$. The distance needed to reach this speed is

$$h = \frac{v_T^2}{2g} = \frac{(3.55)^2}{2(9.8)} = 0.64 \text{ m}$$

- 3.49 A truck is moving forward at a constant speed of 21 m/s. The driver sees a stationary car directly ahead at a distance of 110 m. After a "reaction time" of Δt , he applies the brakes, which gives the truck an acceleration of -3 m/s^2 . (a) What is the maximum allowable Δt to avoid a collision, and what distance will the truck have moved before the brakes take hold? (b) Assuming a reaction time of 1.4 s, how far behind the car will the truck stop, and in how many seconds from the time the driver first saw the car?

▮ The total displacement of the truck from the instant the driver sees the car is $x = v_0 \Delta t + x_A$, where x_A is the displacement from the point of deceleration to the point of rest. We are given $v_0 = 21 \text{ m/s}$ and the deceleration is $a = -3 \text{ m/s}^2$. x_A can be obtained from the equation $v_f^2 = v_0^2 + 2ax_A$, with $v_f = 0$. Thus $x_A = -v_0^2/2a$, or $x_A = -(21 \text{ m/s})^2/(-6 \text{ m/s}^2) = 73.5 \text{ m}$.

(a) To find the maximum Δt , we note that $x_{\text{max}} = 110 \text{ m}$ and $x_{\text{max}} = (21 \text{ m/s}) \Delta t_{\text{max}} + x_A$, or $110 \text{ m} = (21 \text{ m/s}) \Delta t_{\text{max}} + 73.5 \text{ m}$, and $\Delta t_{\text{max}} = 1.74 \text{ s}$. The distance moved before braking started is of course just $v_0 \Delta t = 36.5 \text{ m}$.

(b) If $\Delta t = 1.4 \text{ s}$, then $x = (21 \text{ m/s})(1.4 \text{ s}) + 73.5 \text{ m} = 102.9 \text{ m}$. The distance to the car is just $110 \text{ m} - 102.9 \text{ m} = 7.1 \text{ m}$. To find the time, we need to know the time t during which the truck accelerates. We have $v_f = v_0 + at$, with again $v_f = 0$ and $a = -3 \text{ m/s}^2$. Then $0 = 21 \text{ m/s} - (3 \text{ m/s}^2)t$ and $t = 7 \text{ s}$. The total time is $t + \Delta t = 7 + 1.4 = 8.4 \text{ s}$.

- 3.50 Just as a car starts to accelerate from rest with acceleration 1.4 m/s^2 , a bus moving with constant speed of 12 m/s passes it in a parallel lane. (a) How long before the car overtakes the bus? (b) How fast will the car then be going? (c) How far will the car then have gone?

▮ The car starts with initial velocity zero and acceleration $a_c = 1.4 \text{ m/s}^2$, while the bus has constant velocity $v_b = 12 \text{ m/s}$. (b) Both travel the same distance x in time t , so set $a_c t^2/2 = v_b t$ to give $t = 17 \text{ s}$. (b) The final velocity of the car is $v = a_c t = 24 \text{ m/s}$. (c) The average velocity of the car (or the bus's fixed velocity) times 17 s yields $x = 204 \text{ m}$.

- 3.51 A monkey in a perch 20 m high in a tree drops a coconut directly above your head as you run with speed 1.5 m/s beneath the tree. (a) How far behind you does the coconut hit the ground? (b) If the monkey had really wanted to hit your toes, how much earlier should the coconut have been dropped?

▮ The time for the coconut to fall 20 m is given by $20 = gt^2/2$, or 2.02 s. Distance $x = (1.5 \text{ m/s})(2.02 \text{ s}) = 3.03 \text{ m}$. Since you are moving at a fixed speed the monkey should have dropped the coconut 2.02 s earlier.

- 3.52 Two balls are dropped to the ground from different heights. One ball is dropped 2 s after the other but they both strike the ground at the same time, 5 s after the first is dropped. (a) What is the difference in the heights at which they were dropped? (b) From what height was the first dropped?

▮ The time to fall from the greater height h_1 is $t = 5$ s; the time from the lesser height h_2 is $t - 2 = 3$ s. Using $y = at^2/2$, we find (a) the height difference $h_1 - h_2 = g(5^2/2 - 3^2/2) = 78$ m and (b) $h_1 = 9.8(25)/2 = 123$ m.

3.53 Two boys start running straight toward each other from two points that are 100 m apart. One runs with a speed of 5 m/s, while the other moves at 7 m/s. How close are they to the slower one's starting point when they reach each other?

▮ The two boys meet at the same place and time. The time for the slower one to travel a distance x is $x/5$, while the other boy has $t = (100 - x)/7$. Equating the times yields $x = 41.7$ m.

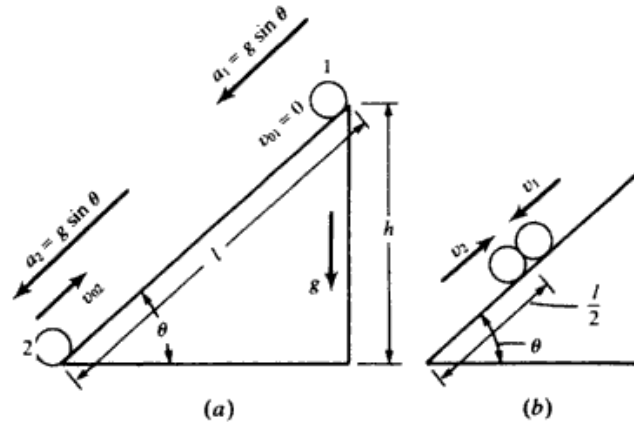

Fig. 3-8

3.54 Body 1, Fig. 3-8, is released from rest at the top of a smooth inclined plane, and at the same instant body 2 is projected upward from the foot of the plane with such velocity that they meet halfway up the plane. Determine (a) the velocity of projection and (b) the velocity of each body when they meet.

▮ (a) In the common time t , body 1 travels the distance

$$\frac{l}{2} = (0)t + \frac{1}{2}(g \sin \theta)t^2$$

and body 2 travels the distance

$$\frac{l}{2} = v_{02}t + \frac{1}{2}(-g \sin \theta)t^2$$

Adding these two equations gives $l = v_{02}t$ or $t = l/v_{02}$. Substituting this value of t in the first equation and solving for v_{02} , we obtain $v_{02} = \sqrt{gl \sin \theta} = \sqrt{gh}$.

(b)
$$v_1^2 = 0^2 + 2(g \sin \theta) \frac{l}{2} \quad \text{or} \quad v_1 = \sqrt{gl \sin \theta} = \sqrt{gh}.$$

$$v_2^2 = v_{02}^2 + 2(-g \sin \theta) \frac{l}{2} = gl \sin \theta - gl \sin \theta = 0 \quad \text{or} \quad v_2 = 0$$

3.55 Two trains are headed toward each other on the same track with equal speeds of 20 m/s. When they are 2 km apart, they see each other and begin to decelerate. (a) If their decelerations are uniform and equal, how large must the acceleration be if the trains are to barely avoid collision? (b) If only one train slows with this acceleration, how far will it go before collision occurs?

▮ (a) Each train stops in 1000 m, so using $v^2 - v_0^2 = 2ax$ yields, for $v_0 = 20$ m/s, an acceleration of -0.2 m/s².

(b) The decelerating train travels a distance $x = 20t - 0.1t^2$, while the other train travels $(2000 - x) = 20t$. Because they collide, times are the same. Eliminating t and solving for x by the quadratic formula yields 828 m.

3.56 A ball after having fallen from rest under the influence of gravity for 6 s crashes through a horizontal glass plate, thereby losing two-thirds of its velocity. If it then reaches the ground in 2 s, find the height of the plate above the ground.

▮ From $v = v_0 + at$, the velocity just before striking the glass is $v_1 = 0 - 9.8(6) = -58.8$ m/s, and so the velocity after passing through glass is $(1/3)v_1 = -19.6$ m/s. Thus $-h = (-19.6)(2) - 4.9(2)^2$, or h = 58.8 m.

- 3.57 An inclined plane, Fig. 3-9, makes an angle θ with the horizontal. A groove OA cut in the plane makes an angle α with OX . A short smooth cylinder is free to slide down the groove under the influence of gravity, starting from rest at the point (x_0, y_0) . Find: (a) its downward acceleration along the groove, (b) the time to reach O , and (c) its velocity at O . Let $\theta = 30^\circ$, $x_0 = 3$ m, $y_0 = 4$ m.

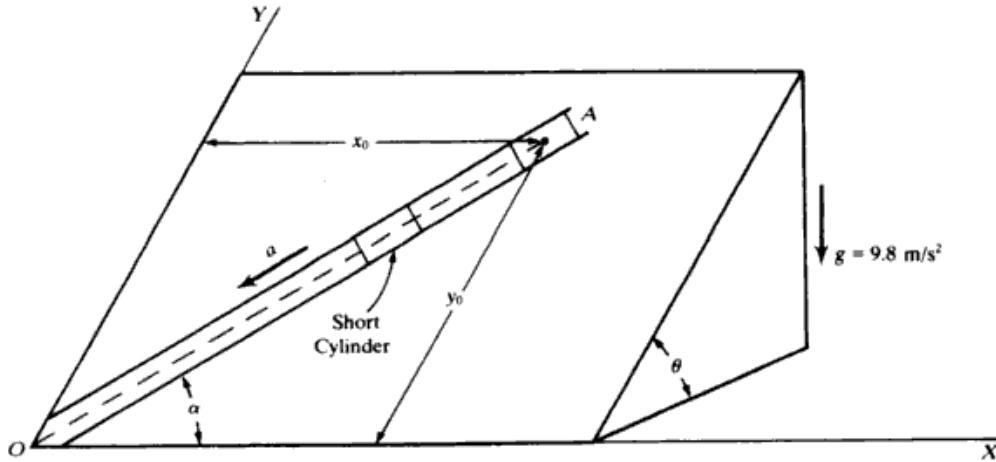

Fig. 3-9

▮ (a) The downward component of g parallel to OY is $g \sin \theta$; hence, the downward component along the groove is $a = g \sin \theta \sin \alpha$. Since

$$\sin \alpha = \frac{y_0}{(x_0^2 + y_0^2)^{1/2}} = 0.8 \quad \text{and} \quad \sin \theta = 0.5 \quad a = (9.8)(0.5)(0.8) = 3.92 \text{ m/s}^2$$

(b) $s = v_0 t + \frac{1}{2} a t^2$, where $s = (x_0^2 + y_0^2)^{1/2} = 5$ m and $v_0 = 0$. Thus, $s = \frac{1}{2}(3.92)t^2$ or $t = 1.597$ s.

(c) $v = 0 + (3.92)(1.597) = 6.26$ m/s.

- 3.58 A bead, Fig. 3-10, is free to slide down a smooth wire tightly stretched between points P_1 and P_2 on a vertical circle of radius R . If the bead starts from rest at P_1 , the highest point on the circle, find (a) its velocity v on arriving at P_2 and (b) the time to arrive at P_2 and show that this time is the same for any chord drawn from P_1 .

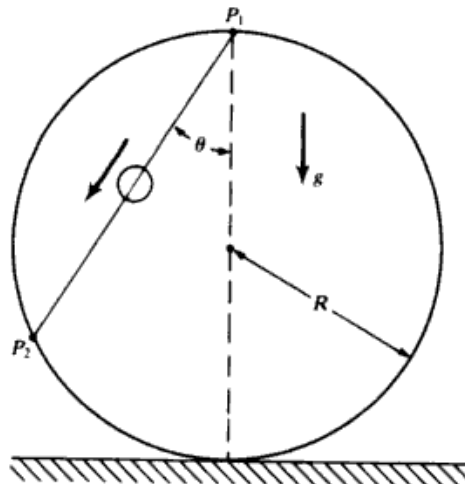

Fig. 3-10

▮ (a) The acceleration of the bead down the wire is $g \cos \theta$ and the length of the wire is $2R \cos \theta$. Hence, $v^2 = 0^2 + 2(g \cos \theta)(2R \cos \theta)$, or $v = 2(\sqrt{gR}) \cos \theta$.

(b)
$$t = \frac{v}{a} = \frac{2\sqrt{gR} \cos \theta}{g \cos \theta} = 2\sqrt{\frac{R}{g}}$$

which is the same regardless of where P_2 is located on the circle.

3.59^c An object is forced to move along the X axis in such a way that its displacement is given by $x = 30 + 20t - 15t^2$ where x is in m and t is in s. (a) Find expressions for the velocity \dot{x} and acceleration \ddot{x} . Is the acceleration constant? (b) What are the initial position and the initial velocity of the object? (c) At what time and distance from the origin is the velocity zero? (d) At what time and location is the velocity -50 m/s?

▮ Remembering that all units are SI and that

$$\dot{x} \equiv \frac{dx}{dt} \quad \ddot{x} \equiv \frac{d^2x}{dt^2}$$

(a) $v = \dot{x} = (20 - 30t)$ m/s; $a = \ddot{x} = -30$ m/s². Acceleration is constant.

(b) At $t = 0$, $x = 30$ m = x_0 , $\dot{x} = 20$ m/s = v_0 .

(c) From the velocity equation, for $v = 0$, $0 = 20 - 30t$ and $t = \frac{2}{3}$ s. Substituting $t = \frac{2}{3}$ s into the displacement equation, $x = 30 + 20(\frac{2}{3}) - 15(\frac{2}{3})^2 = 36.7$ m.

(d) Setting $v = -50$ m/s, $-50 = 20 - 30t$, and $t = 2\frac{1}{3}$ s. Then, $x = 30 + 20(2\frac{1}{3}) - 15(2\frac{1}{3})^2 = -5.0$ m.

(Note that a comparison of the displacement equation with $x = x_0 + v_0t + \frac{1}{2}at^2$ would have made the use of calculus unnecessary.)

3.60^c A particle moving along the x axis has a velocity given by $v = 4t - 2.50t^2$ cm/s for t in seconds. Find its acceleration at (a) $t = 0.50$ s and (b) $t = 3.0$ s.

▮ $a = dv/dt = 4 - 5.0t$, giving (a) $a = 1.50$ cm/s² and (b) -11.0 cm/s².

3.61^c A ball is released from rest at the edge of a deep ravine. Assume that air resistance gives it an acceleration of $-b\dot{y}$, where y is measured positive downward. (This negative acceleration is proportional to its speed, \dot{y} ; the positive constant b can be found by experiment.) The ball has a total acceleration of $-b\dot{y} + g$, and so

$$\ddot{y} = -b\dot{y} + g \tag{1}$$

is the differential equation of motion. (a) Show by differentiation and substitution that

$$y = k(e^{-bt} - 1) + (g/b)t \tag{2}$$

is a solution of (1) for an arbitrary value of the constant k and that (2) gives $y = 0$ for $t = 0$. (b) Since at $t = 0$, $\dot{y} = 0$, prove that $k = g/b^2$ and show that as $t \rightarrow \infty$, $\dot{y} \rightarrow g/b$; that is, the velocity reaches a limiting value such that the negative acceleration due to air resistance exactly offsets the positive acceleration of gravity and thus $\ddot{y} = 0$. (c) Assuming that $b = 0.1$ s⁻¹, find the distance fallen and the speed reached after 10 s. (d) Show that after 1 min the ball will have essentially reached its terminal velocity of 98 m/s.

▮ (a) Differentiating (2) once, $\dot{y} = -bke^{-bt} + g/b$. Differentiating once more, $\ddot{y} = b^2ke^{-bt}$. Multiplying our expression for \dot{y} by $-b$ and adding g yields b^2ke^{-bt} . Thus (1) is satisfied. Substituting $t = 0$ into (2) and recalling that $e^0 = 1$, we get $y = 0$.

(b) Since the ball is released from rest, $\dot{y} = 0$ at $t = 0$. Using our expression for \dot{y} from (a), we have $0 = -bk + g/b$, which yields $k = g/b^2$. As $t \rightarrow \infty$ the first term in \dot{y} becomes infinitesimal and $\dot{y} \rightarrow g/b$. Thus \dot{y} must approach zero, as can be seen directly from the expression for \ddot{y} .

(c) If $b = 0.1$ /s and using $g = 9.8$ m/s², we have $k = g/b^2 = 980$ m. Then at $t = 10$ s, $y = (980 \text{ m})(e^{-1} - 1) + (98 \text{ m/s})(10 \text{ s}) = 360$ m. $v = \dot{y} = (-98 \text{ m/s})e^{-1} + (9.8 \text{ m/s}^2)/(0.1 \text{ s}) = 62$ m/s.

(d) At $t = 60$ s, $\dot{y} = (-98 \text{ m/s})e^{-6} + 98 \text{ m/s}$. $e^{-6} \approx 0.0025$, so $\dot{y} \approx 98$ m/s.

3.62^c A ball is thrown vertically upward from the origin of axes (Y regarded + upward), with initial velocity \dot{y}_0 . Assuming as in Prob. 3.61 an acceleration $-b\dot{y}$ due to air resistance, we write

$$\ddot{y} = -b\dot{y} - g \tag{1}$$

[Note that when \dot{y} changes sign, so does $-b\dot{y}$; hence (1) is valid for the trip down as well as the trip up]. (a) Show that $y = k(e^{-bt} - 1) - (g/b)t$ is a solution of (1) for any value of k . (b) Prove that

$$k = -\frac{1}{b} \left(\dot{y}_0 + \frac{g}{b} \right)$$

(c) Assuming that $b = 0.1 \text{ s}^{-1}$ and $\dot{y}_0 = 50 \text{ m/s}$, find the height and speed at $t = 3 \text{ s}$. (d) How long does it take for the ball to attain its maximum height and what is the height?

| (a) $\dot{y} = -bke^{-bt} - g/b$, $\ddot{y} = b^2ke^{-bt}$. Multiplying \dot{y} by $-b$ and subtracting g yields \ddot{y} , which proves y is a solution of (1). (b) At $t = 0$, $\dot{y} = \dot{y}_0 = -bk - g/b$. Solving for k , $k = -(\dot{y}_0 + g/b)/b$.

(c) Again $b = 0.1 \text{ s}$, and we are told $\dot{y}_0 = 50 \text{ m/s}$. Then $k = -(50 + 98)/0.1 = -1480 \text{ m}$. At $t = 3 \text{ s}$, we have $y = -1480(e^{-0.3} - 1) - (98)(3) = \underline{89.6 \text{ m}}$. $\dot{y} = +148e^{-0.3} - 98 = \underline{11.6 \text{ m/s}}$.

(d) For maximum height, $\dot{y} = 0$, which yields $0 = 148e^{-0.1t} - 98$, or $e^{0.1t} = 1.51$. Thus $t = \underline{4.12 \text{ s}}$. Substituting $t = 4.12 \text{ s}$ into the y equation yields $y = -1480(e^{-0.412} - 1) - (98)(4.12) = \underline{96.0 \text{ m}}$.

3.63^c A mass at the end of a spring vibrates up and down according to the equation $y = 8 \sin 1.5t \text{ cm}$, where t is the time in seconds and the complete argument (angle) of the sine function, $1.5t$, is in radians. (a) What is the velocity of the mass at $t = 0.75 \text{ s}$? (b) At $t = 3.0 \text{ s}$? (c) What is the maximum velocity of the mass? (Hint: To express the angle in degrees, multiply it by $180/\pi$.)

| The velocity $v = dy/dt = (1.5)(8) \cos 1.5t \text{ cm/s}$; remember that $1.5t$ is expressed in radians. (a) $v = 12 \cos 1.13 = \underline{5.2 \text{ cm/s}}$. (b) $v = 12 \cos 4.5 = \underline{-2.5 \text{ cm/s}}$. (c) Maximum occurs where the cosine is ± 1 , so $v = \underline{\pm 12.0 \text{ cm/s}}$.

CHAPTER 4

Newton's Laws of Motion

4.1 FORCE, MASS, AND ACCELERATION

- 4.1 A force acts on a 2-kg mass and gives it an acceleration of 3 m/s^2 . What acceleration is produced by the same force when acting on a mass of (a) 1 kg? (b) 4 kg? (c) How large is the force?

| We first find the force F using $F = ma$ (one dimension). $F = (2 \text{ kg})(3 \text{ m/s}^2) = 6 \text{ N}$. Then noting $a = F/m$, we have for the different masses $m = 1 \text{ kg}$, $a = (6 \text{ N})/(1 \text{ kg}) = 6 \text{ m/s}^2$; $m = 4 \text{ kg}$, $a = 1.5 \text{ m/s}^2$. The answers are thus (a) 6 m/s^2 (b) 1.5 m/s^2 (c) 6 N .

- 4.2 (Fill in the blanks.) The mass of a 300 g object is _____. (a) Its weight on earth is _____. (b) An object that weighs 20 N on earth has a mass on the moon equal to _____. (c) The mass of an object that weighs 5 lb on earth is _____. (d)

| (a) 300 g (b) $w = (300 \text{ g})(980 \text{ cm/s}^2) = 2.94 \times 10^5 \text{ dyn} = 2.94 \text{ N}$. (c) $m = w/g = (20 \text{ N})/(9.8 \text{ m/s}^2) = 2.04 \text{ kg}$; mass is the same anywhere. (d) $m = w/g = (5 \text{ lb})/(32.2 \text{ ft/s}^2) = 0.155 \text{ slug}$.

- 4.3 A resultant external force of 7.0 lb acts on an object that weighs 40 lb on earth. What is the object's acceleration (a) on earth? (b) on the moon?

| (a) We use $F = ma$, where we recall that F stands for the resultant of all forces acting on the mass m . To get m we note that $m = w/g = (40 \text{ lb})/(32.2 \text{ ft/s}^2) = 1.24 \text{ slug}$. Then $a = F/m = (7.0 \text{ lb})/(1.24 \text{ slug}) = 5.64 \text{ ft/s}^2$. (b) The acceleration on the moon is the same since the resultant force is still 7.0 lb and the mass is the same anywhere.

- 4.4 A horizontal cable pulls a 200-kg cart along a horizontal track. The tension in the cable is 500 N. Starting from rest, (a) how long will it take the cart to reach a speed of 8 m/s? (b) How far will it have gone?

| Assuming no friction, the tension in the cable is the only horizontal force. Then from $F_x = ma_x$ we get $a_x = (500 \text{ N})/(200 \text{ kg}) = 2.50 \text{ m/s}^2$. We now use kinematics to solve the problem.

(a) $v_x = v_{0x} + a_x t$; and since the cart starts from rest, $v_{0x} = 0$. Then $t = v_x/a_x = (8 \text{ m/s})/(2.50 \text{ m/s}^2) = 3.2 \text{ s}$. (b) Letting the starting point be the origin we have $x = v_{0x}t + \frac{1}{2}at^2 = 0 + \frac{1}{2}(2.50 \text{ m/s}^2)(3.2 \text{ s})^2 = 12.8 \text{ m}$

- 4.5 A 900-kg car is going 20 m/s along a level road. How large a constant retarding force is required to stop it in a distance of 30 m?

| Here we start with the kinematical equation that allows us to find the acceleration a_x : $v_x^2 = v_{0x}^2 + 2a_x x$, where $v_x = 0$ when $x = 30 \text{ m}$ and $v_{0x} = 20 \text{ m/s}$. Solving we obtain $a_x = -6.67 \text{ m/s}^2$. Finally we solve for the retarding force using $F_x = ma_x = (900 \text{ kg})(-6.67 \text{ m/s}^2) = -6000 \text{ N}$.

- 4.6 How much force does it take to give a 20 000-kg locomotive an acceleration of 1.5 m/s^2 on a level track with a coefficient of rolling friction of 0.03?

| Refer to Fig. 4-1. $F - \mu_k N = ma$, $N = mg$, $F = \mu_k mg + ma = 0.03(20\,000)(9.8) + 20\,000(1.5) = 5880 + 30\,000 = 35.880 \text{ kN}$

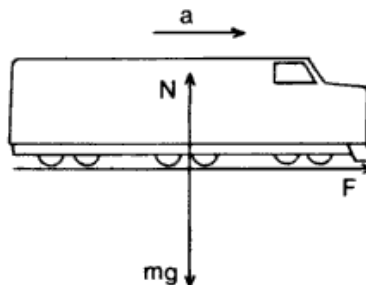

Fig. 4-1

- 4.7 A 12.0-g bullet is accelerated from rest to a speed of 700 m/s as it travels 20 cm in a gun barrel. Assuming the acceleration to be constant, how large was the accelerating force?

▮ From kinematics we have $v_x^2 = v_{0x}^2 + 2a_x x$. For our case $v_{0x} = 0$, and $v_x = 700$ m/s when $x = 0.20$ m. Solving we get $a_x = 1.23 \cdot 10^6$ m/s². We then obtain F_x by noting $m = 0.012$ kg and using $F_x = ma_x = \underline{14.8 \text{ kN}}$.

- 4.8 A 20-kg crate hangs at the end of a long rope. Find its acceleration when the tension in the rope is (a) 250 N, (b) 150 N, (c) zero, (d) 196 N.

▮ The crate is acted on by two vertical forces—the tension in the rope, T , upward and the weight of the crate, $w = mg$, downward. Noting that $w = (20 \text{ kg})(9.8 \text{ m/s}^2) = 196$ N and using $T - w = ma_y$, we get: (a) $a_y = \underline{2.7 \text{ m/s}^2}$; (b) $a_y = \underline{-2.3 \text{ m/s}^2}$; (c) $a_y = \underline{-9.8 \text{ m/s}^2}$; (d) $a_y = 0$. Note that negative acceleration is downward for our case.

- 4.9 A 40-kg trunk sliding across a floor slows down from 5.0 to 2.0 m/s in 6.0 s. Assuming that the force acting on the trunk is constant, find its magnitude and its direction relative to the velocity vector of the trunk.

▮ Letting the x axis be along the direction of motion, we have for the magnitude of the resultant force $F_x = ma_x$. To find a_x , we use the kinematical relationship $v_x = v_{0x} + a_x t$, with $v_{0x} = 5.0$ m/s, $v_x = 2.0$ m/s, $t = 6.0$ s. Solving we get $a_x = \underline{-0.50 \text{ m/s}^2}$. Then $F_x = (40 \text{ kg})(-0.50 \text{ m/s}^2) = \underline{-20 \text{ N}}$. Noting that the resultant force in the y direction is zero since $a_y = 0$, we have our answer, \mathbf{F} is 20 N in the direction opposite to the velocity.

- 4.10 A resultant force of 20 N gives a body of mass m an acceleration of 8.0 m/s², and a body of mass m' an acceleration of 24 m/s². What acceleration will this force cause the two masses to acquire if fastened together?

▮ From $F = ma$, with $F = 20$ N and $a = 8.0$ m/s², we get $m = 2.50$ kg. From $F = m'a'$ and $a' = 24.0$ m/s² we get $m' = 0.83$ kg. Combining the two masses yields $M = m + m' = 3.33$ kg and $F = MA$ yields $\underline{A = 6.0 \text{ m/s}^2}$.

- 4.11 An 1100-kg car travels on a straight highway with a speed of 30 m/s. The driver sees a red light ahead and applies her brakes, which exert a constant braking force of 4 kN. (a) What is the deceleration of the car? (b) In how many seconds will the car stop?

▮ (a) Use Newton's second law of motion. Take a retarding force to be negative.

$$F = ma \quad -4 \times 10^3 = 1100a \quad a = -3.636 \text{ m/s}^2$$

Thus, the deceleration is 3.636 m/s².

(b) $a = \frac{v - v_0}{t}$ where v equals zero after t seconds, and v_0 equals 30 m/s.

$$-3.636 = \frac{0 - 30}{t} \quad t = 30/3.636 = \underline{8.25 \text{ s}}$$

The car will come to a stop in 8.25 s.

- 4.12 A force of 70 N gives an object of unknown mass an acceleration of 20 ft/s². What is the object's mass?

▮ $F = ma \quad \frac{F}{a} = m \quad m = \frac{70 \text{ N}}{(20 \text{ ft/s}^2)(0.305 \text{ m/ft})} = \frac{70 \text{ kg} \cdot \text{m/s}^2}{6.10 \text{ m/s}^2} = \underline{11.5 \text{ kg}}$

- 4.13 A boy having a mass of 75 kg holds in his hands a bag of flour weighing 40 N (Fig. 4-2). With what force does the floor push up on his feet?

▮ For the boy to be in equilibrium, the floor must push up on the boy's feet with a force F equal and opposite to the combined weight of the flour and the boy. Let m equal the mass of the boy and w the weight of the flour:

$$F = mg + w = 75(9.8) + 40 = 735 + 40 = \underline{775 \text{ N}}$$

- 4.14 Apply Newton's third law in the following situation: Two drivers, one owning a large Cadillac and the other owning a small Volkswagen, make a bet. The VW owner bets that his car can pull as hard as the Cadillac. They chain the two rear bumpers together in a large empty parking lot. Each driver gets into his car and applies full power. The Cadillac pulls the VW backward all over the lot. The driver of the VW later claims

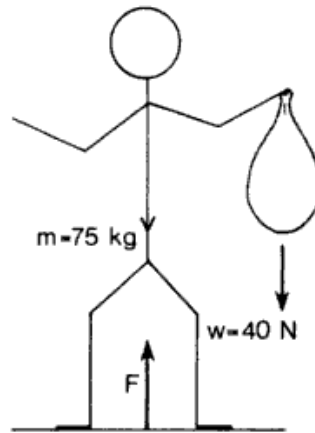

Fig. 4-2

that his car was pulling on the chain as hard as the Cadillac all the time. What does Newton's third law say in this case? Assume that the chain has negligible mass.

Newton's third law says that the VW owner is right. Each car must pull on the chain with the same magnitude of force, one being the action and the other the reaction. The motion of the VW is a consequence of *all* the forces acting on it, not just the force of the chain. These other forces include, in particular, the frictional force between tires and road, which is quite different for the VW and the Cadillac.

- 4.15 A 2-slug mass pulls horizontally on a 3-slug mass by means of a lightly stretched spring (Fig. 4-3). If at one instant the 3-slug mass has an acceleration toward the 2-slug mass of 1.8 ft/s^2 , find the net force on the 2-slug mass and its acceleration at that instant.

The spring pulls on each mass with the same force F but in opposite directions. Using Newton's second law,

$$F = m_1 a_1 = m_2 a_2 \quad F = m_2 a_2 = 3 \text{ slug} \times 1.8 \text{ ft/s}^2 = 5.4 \text{ slug} \cdot \text{ft/s}^2 \quad F = \underline{5.4 \text{ lb}}$$

Using Newton's second law on the mass m_1 ,

$$F = m_1 a_1 = 5.4 \text{ lb} \quad 2a_1 = 5.4 \quad a_1 = \underline{2.7 \text{ ft/s}^2}$$

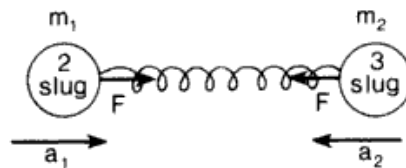

Fig. 4-3

- 4.16 A 96-lb boy is standing in an elevator. Find the force on the boy's feet when the elevator (a) stands still (b) moves downward at a constant velocity of 3 ft/s (c) accelerates downward with an acceleration of 4.0 ft/s^2 , and (d) accelerates upward with an acceleration of 4.0 ft/s^2 .

(a) Find the mass of the boy in the proper unit, the slug:

$$m = \frac{\text{weight } (w)}{\text{acceleration of gravity } (g)} = \frac{96 \text{ lb}}{32 \text{ ft/s}^2} = 3 \text{ lb} \cdot \text{s}^2/\text{ft} = 3 \text{ slug}$$

When an elevator stands still, the force on the boy's feet, according to Newton's first law, is equal and opposite to his weight. The answer is therefore 96 lb upward.

(b) A constant velocity means zero acceleration. For zero acceleration the force of the elevator balances the earth's downward gravitational force, that is, the weight of the boy. Again by Newton's first law, the answer is 96 lb upward.

(c) When the acceleration of the elevator is downward, the boy's weight exceeds the upward force E of the elevator, yielding a net downward force F . From Fig. 4-4

$$F = ma = 3 \text{ slug} \times 4.0 \text{ ft/s}^2 = 12 \text{ lb s}^2/\text{ft} \times \text{ft/s}^2 \quad F = 12 \text{ lb} \quad E = w - F = 96 - 12 = \underline{84 \text{ lb}}$$

By Newton's second law, the floor of the elevator pushes upward on the boy's feet with a force of 84 lb.

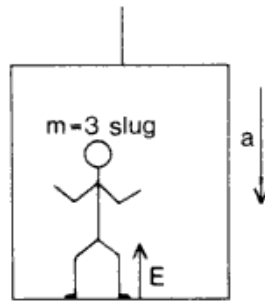

Fig. 4-4

(d) When the elevator accelerates at 4.0 ft/s^2 upward, the force E acting on the boy is greater than his weight w by an amount $F = 12 \text{ lb}$:

$$E = w + F = 96 + 12 = \underline{108 \text{ lb}} \text{ upward}$$

- 4.17 An elevator starts from rest with a constant upward acceleration. It moves 2.0 m in the first 0.60 s . A passenger in the elevator is holding a 3-kg package by a vertical string. What is the tension in the string during the accelerating process?

▮ To obtain the tension T in the string we apply the second law to the $m = 3.0 \text{ kg}$ package: $T - w = ma_y$, with $w = mg = \underline{29.4 \text{ N}}$. The acceleration a of the package is the same as that of the elevator; it is obtained from the displacement formula $y = v_{0y}t + \frac{1}{2}a_y t^2$, where $v_{0y} = 0$ and $y = 2.0 \text{ m}$, when $t = 0.60 \text{ s}$. Solving we get $a_y = \underline{11.1 \text{ m/s}^2}$. Substituting into our equation for T , we get $T = \underline{62.7 \text{ N}}$.

- 4.18 Just as her parachute opens, a 150-lb parachutist is falling at a speed of 160 ft/s . After 0.80 s has passed, the chute is fully open and her speed has dropped to 35 ft/s . Find the average retarding force exerted upon the chutist during this time.

▮ We choose downward as the positive y direction. The average acceleration of the chutist over the 0.80-s interval is

$$\bar{a}_y = \frac{(35 - 160)\text{ft/s}}{0.80 \text{ s}} = -156 \text{ ft/s}^2$$

Next we use: $\sum \bar{F}_y = m\bar{a}_y$, or $w - \bar{T} = m\bar{a}_y$, with $w = 150 \text{ lb}$, $m = w/g = 4.69 \text{ slug}$, and \bar{T} = the average retarding force due to the chute. Solving we get $\bar{T} = \underline{881 \text{ N}}$.

- 4.19 A boy who normally weighs 300 N on a bathroom scale crouches on the scale and suddenly jumps upward. His companion notices that the scale reading momentarily jumps up to 400 N as the boy springs upward. Estimate the boy's maximum acceleration in this process.

▮ The maximum upward force exerted by the scale on the boy is 400 N . The net force on the boy is $(400 - 300) \text{ N}$ and this equals ma . Using $m = 300/9.8$ yields $a = \underline{3.3 \text{ m/s}^2}$.

- 4.20 Shortly after leaping from an airplane a 91.8-kg man has an upward force of 225 N exerted on him by the air. Find the resultant force on the man.

▮ The resultant force on the man is the vector sum of two forces—the weight $w = mg = (91.8 \text{ kg})(9.8 \text{ m/s}^2) = 900 \text{ N}$ downward, and the 225-N force upward. Then the resultant force is $900 - 225 = \underline{675 \text{ N}} \text{ downward}$.

- 4.21 To measure the mass of a box, we push it along a smooth surface, exerting a net horizontal force of 150 lb . The acceleration is observed to be 3.0 m/s^2 . What is the mass of the box?

▮ Using $F_x = ma_x$ for the horizontal direction we get $150 \text{ lb} \times 4.45 \text{ N/lb} = m(3.0 \text{ m/s}^2)$ and $m = \underline{223 \text{ kg}}$.

- 4.22 A book sits on a horizontal top of a car as the car accelerates horizontally from rest. If the static coefficient of friction between car top and book is 0.45 , what is the maximum acceleration the car can have if the book is not to slip?

▮ When the book of mass m is about to slide, the friction $f = \mu mg$. Friction is the only horizontal force acting, thus $f = ma$. Inserting $\mu = 0.45$ yields $a = \mu g = \underline{4.41 \text{ m/s}^2}$.

- 4.23** Prove the following for a car moving on a horizontal road: The magnitude of the car's acceleration cannot exceed μg , where μ is the coefficient of friction between tires and road. What is the similar expression for the acceleration of a car going up an incline whose angle is θ ?

| Friction between tires and road supplies the force moving the car, so $f = ma$. On a horizontal road $F_N = mg$, so $f_{\max} = \mu F_N = \mu mg$, therefore $a_{\max} = \mu g$. On the incline, equations of motion parallel and perpendicular to the surface are $\mu F_N - mg \sin \theta = ma_{\max}$ and $F_N - mg \cos \theta = 0$. Solve for a : $a_{\max} = (\mu \cos \theta - \sin \theta)g$.

- 4.24** A 5-kg mass hangs at the end of a cord. Find the tension in the cord if the acceleration of the mass is (a) 1.5 m/s^2 up, (b) 1.5 m/s^2 down, and (c) 9.8 m/s^2 down.

| Choosing upward as positive we have $T - w = ma_y$, where T is the tension in the cord, $m = 5 \text{ kg}$, and $w = mg = 49 \text{ N}$ is the weight of the mass.

(a) $T = 56.5 \text{ N}$ (b) $T = 41.5 \text{ N}$ (c) $T = 0$.

- 4.25** A 700-N man stands on a scale on the floor of an elevator. The scale records the force it exerts on whatever is on it. What is the scale reading if the elevator has an acceleration of (a) 1.8 m/s^2 up? (b) 1.8 m/s^2 down? (c) 9.8 m/s^2 down?

| Again choosing upward as positive and letting N represent the force of the scale on the man, we have $N - w = ma_y$. Noting that $w = 700 \text{ N}$, and that $m = w/g = 71.4 \text{ kg}$, we solve for N using the values of a_y given:

(a) $N = 829 \text{ N}$. (b) $N = 571 \text{ N}$. (c) $N = 0$.

- 4.26** Using the scale described in Prob. 4.25, a 65-kg astronaut weighs himself on the moon, where $g = 1.60 \text{ m/s}^2$. What does the scale read?

| Since g_{moon} is the acceleration of free fall on the moon, and w_{moon} is the force of gravity on the moon's surface, we have $w_{\text{moon}} = mg_{\text{moon}} = (65 \text{ kg})(1.60 \text{ m/s}^2) = 104 \text{ N}$. By Newton's first law scale reads 104 N .

- 4.27** A rough rule of thumb states that the frictional force between dry concrete and a skidding car's tires is about equal to nine-tenths of the car's weight. If the skid marks left by a car in coming to rest are 20 m long, about how fast was the car going just before the brakes were applied?

| Since $|f| = \mu |F_N|$, and since $F_N = W$ on level ground, we have for $\mu = 0.9$, $f = -0.9W$. Find the car's acceleration from $F = ma$, which is $f = (W/g)a$ with $f = -0.9W$. Then $a = -0.9g$. Since x is 20 m, use $v^2 - v_0^2 = 2ax$ with $v = 0$, to give $v_0 = 6g^{1/2} = 18.8 \text{ m/s}$.

- 4.28** If the coefficient of friction between a car's wheels and a roadway is 0.70, what is the least distance in which the car can accelerate from rest to a speed of 15 m/s?

| Using $a = \mu g$ (see Probs. 4.23 and 4.27) in the kinematical formula $v^2 = v_0^2 + 2ax$,

$$x = \frac{v^2 - v_0^2}{2a} = \frac{15^2 - 0^2}{2(0.70)(9.8)} = 16.4 \text{ m}$$

- 4.29** A constant force accelerates an electron ($m = 9.1 \times 10^{-31} \text{ kg}$) from rest to a speed of $5 \times 10^7 \text{ m/s}$ in a distance of 0.80 cm. Determine this force. How many times larger than mg is it?

| First find the constant acceleration from $v^2 - v_0^2 = 2ax$; then $a = 25 \times 10^{14} / 1.6 \times 10^{-2} = 1.56 \times 10^{17} \text{ m/s}^2$, so $F = ma = (9.1 \times 10^{-31})(1.56 \times 10^{17}) = 1.43 \times 10^{-13} \text{ N}$. Then $F/mg = a/g = 1.56 \times 10^{17} / 9.8 = 1.6 \times 10^{16}$.

- 4.30** The 4.0-kg head of a sledge hammer is moving at 6.0 m/s when it strikes a spike, driving it into a log; the duration of the impact (or the time for the sledge hammer to stop after contact) is 0.0020 s. Find (a) the time average of the impact force, (b) the distance the spike penetrates the log.

| (a) The average force is a constant force that would effect the same result as the actual time-varying force over the time interval involved. For a constant force we can use $v_x = v_{0x} + a_x t$ to find the corresponding constant acceleration a_x . Here $v_{0x} = 6.0 \text{ m/s}$, $v_x = 0$, and $t = 0.0020 \text{ s}$. Solving we get $a_x = -3000 \text{ m/s}^2$. Then $F_x = ma_x$ yields $F_x = -12 \text{ kN}$. Here F_x represents the force of the spike on the hammer-head. The reaction force on the spike is the impact force, which is 12 kN .

(b) The spike moves the same distance as the hammerhead in the time interval in question. For the hammerhead we have $x = v_{0x}t + \frac{1}{2}a_x t^2 = (6.0 \text{ m/s})(0.0020 \text{ s}) + \frac{1}{2}(-3000 \text{ m/s}^2)(0.0020 \text{ s})^2 = 0.006 \text{ m}$ or $x = 6.0 \text{ mm}$.

- 4.31^f** A body of mass m moves along Y such that at time t its position is $y(t) = at^{3/2} - bt + c$, where a, b, c are constants. **(a)** Calculate the acceleration of the body. **(b)** What is the force acting on it?
| **(a)** $a_y = d^2y/dt^2$. We first obtain $v_y = dy/dt = \frac{3}{2}at^{1/2} - b$ and then $d^2y/dt^2 = \frac{3}{4}at^{-1/2}$. To obtain the force we have **(b)** $F = ma_y = \frac{3}{4}mat^{-1/2}$
- 4.32^f** Measurements on a 300-g object moving along the x axis show its position (in centimeters) to be given by $x = 0.20t - 5.0t^2 + 7.5t^3$, where t is the time in seconds. Find the net force that acted on the object during the time for which this expression applies.
| Because $F_{\text{net}} = ma$, we must find a ; $a = dv/dt$ and $v = dx/dt$. Doing the differentiations, $v = 0.20 - 10.0t + 22.5t^2$, $a = -10.0 + 45t$; so $F_{\text{net}} = 300(-10.0 + 45t)$ dyn = $0.00300(-10.0 + 45t)$ N
- 4.33^f** A 50-g mass vibrating up and down at the end of a spring has its position given by $y = 0.150 \sin 3t$ m for t in seconds. Find the net force that acts on the mass to give it this motion.
| The acceleration is $d^2y/dt^2 = -1.35 \sin 3t$ m/s²; so $F_{\text{net}} = 0.050(-1.35 \sin 3t) = \underline{-0.0675 \sin 3t}$ N. The minus sign indicates a restoring force.
- 4.34^f** A body of mass m moves along X such that at time t its position is $x(t) = \alpha t^4 - \beta t^3 + \gamma t$, where α, β, γ are constants. **(a)** Calculate the acceleration of the body. **(b)** What is the force acting on it?
| **(a)** $\dot{x} = 4\alpha t^3 - 3\beta t^2 + \gamma$ and $\ddot{x} = 12\alpha t^2 - 6\beta t$
(b) $F_x = m\ddot{x} = 12m\alpha t^2 - 6m\beta t$

4.2 FRICTION; INCLINED PLANES; VECTOR NOTATION

- 4.35** The breaking strength of a steel cable is 20 kN. If one pulls horizontally with this cable, what is the maximum horizontal acceleration which can be given to an 8-ton (metric) body resting on a rough horizontal surface if the coefficient of kinetic friction is 0.15?
| Let T be the cable force. Then $\sum F = ma$ becomes $T - \mu_k mg = ma$. For maximum acceleration $T = 2.0 \times 10^4$ N, so that 2.0×10^4 N - $0.15(8000 \text{ kg})(9.8 \text{ m/s}^2) = (8000 \text{ kg})a$. Solving we get $a = \underline{1.03 \text{ m/s}^2}$.
- 4.36** A 20-kg wagon is pulled along the level ground by a rope inclined at 30° above the horizontal. A friction force of 30 N opposes the motion. How large is the pulling force if the wagon is moving with **(a)** constant speed, and **(b)** an acceleration of 0.40 m/s²?
| Let the pulling force of the rope be T . Using $\sum F_x = ma_x$, we have for our case $T \cos 30^\circ - 30 \text{ N} = ma_x$, where $m = 20$ kg. **(a)** For $a_x = 0$, $T = \underline{34.6 \text{ N}}$. **(b)** For $a_x = 0.40 \text{ m/s}^2$, $T = \underline{43.9 \text{ N}}$
- 4.37** Suppose, as shown in Fig. 4-5, that a 70-kg box is pulled by a 400-N force at an angle of 30° to the horizontal. The coefficient of sliding friction is 0.50. Find the acceleration of the box.
| Because the box does not move vertically, $\sum F_y = ma_y = 0$. From Fig. 4-5, we see that this equation is $Y + 200 \text{ N} - mg = 0$. But $mg = (70 \text{ kg})(9.8 \text{ m/s}^2) = 686 \text{ N}$. It follows that $Y = 486 \text{ N}$. We can find the friction force acting on the box by writing $f = \mu Y = (0.50)(486 \text{ N}) = 243 \text{ N}$. Now let us write $\sum F_x = ma_x$ for the box. It is $(346 - 243) \text{ N} = (70 \text{ kg})a_x$, from which $a_x = \underline{1.47 \text{ m/s}^2}$.

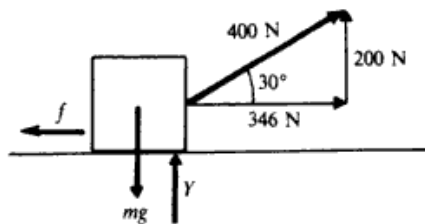

Fig. 4-5

- 4.38** As shown in Fig. 4-6, a force of 400 N pushes on a 25-kg box. Starting from rest, the box achieves a velocity of 2.0 m/s in a time of 4 s. Find the coefficient of sliding friction between box and floor.

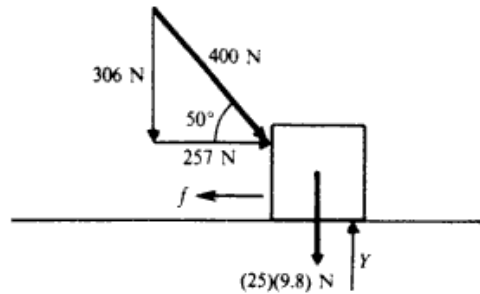

Fig. 4-6

■ We must find f by use of $F = ma$. But first we must find a from a motion problem. We know that $v_0 = 0$, $v_f = 2 \text{ m/s}$, $t = 4 \text{ s}$. Using $v_f = v_0 + at$ gives

$$a = \frac{v_f - v_0}{t} = \frac{2 \text{ m/s}}{4 \text{ s}} = 0.50 \text{ m/s}^2$$

Now we can write $\sum F_x = ma_x$, where $a_x = a = 0.50 \text{ m/s}^2$. From Fig. 4-6, this equation is $257 \text{ N} - f = (25 \text{ kg})(0.50 \text{ m/s}^2)$, or $f = 245 \text{ N}$. We now wish to use $\mu = f/Y$. To find Y , we write $\sum F_y = ma_y = 0$, since no vertical motion occurs. From Fig. 4-6, $Y - 306 \text{ N} - (25)(9.8) \text{ N} = 0$, or $Y = 551 \text{ N}$. Then

$$\mu = \frac{f}{Y} = \frac{245}{551} = 0.44$$

- 4.39 A 12-kg box is released from the top of an incline that is 5.0 m long and makes an angle of 40° to the horizontal. A 60-N friction force impedes the motion of the box. (a) What will be the acceleration of the box and (b) how long will it take to reach the bottom of the incline?

■ In Fig. 4-7 we show the three forces acting on the block: the frictional force $f = 60 \text{ N}$; the normal force N , which is perpendicular to the incline; and the weight of the block, $w = mg = (12 \text{ kg})(9.8 \text{ m/s}^2) = 118 \text{ N}$. We choose the x axis along the incline with downward as positive. Using $\sum F_x = ma_x$, we have $w \sin 40^\circ - f = ma_x$, or $(118 \text{ N})(0.642) - (60 \text{ N}) = (12 \text{ kg})a_x$. Solving we have $a_x = 1.31 \text{ m/s}^2$. To find the time to reach the bottom of the incline, starting from rest, we use $x = v_{0x}t + \frac{1}{2}a_x t^2$, with $v_{0x} = 0$ and $x = 5.0 \text{ m}$. Solving we get $t = (7.63 \text{ s}^2)^{1/2} = 2.76 \text{ s}$.

- 4.40 For the situation outlined in Prob. 4.39, what is the coefficient of friction between box and incline?

■ Again referring to Fig. 4-7 we have from $\sum F_y = 0$, $N - w \cos 40^\circ = 0$, or $N = 90 \text{ N}$. Then, recalling that the coefficient of kinetic friction is given by $\mu_k = f/N$, we have $\mu_k = 0.67$.

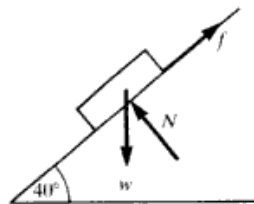

Fig. 4-7

- 4.41 An inclined plane makes an angle of 30° with the horizontal. Find the constant force, applied parallel to the plane, required to cause a 15-kg box to slide (a) up the plane with acceleration 1.2 m/s^2 and (b) down the incline with acceleration 1.2 m/s^2 . Neglect friction forces.

■ Here we assume that the x axis is along the incline and positive upward. If P is the constant force referred to, then from $\sum F_x = ma_x$ we have $P - w \sin 30^\circ = ma_x$, with $m = 15 \text{ kg}$ and $w = mg = 147 \text{ N}$.

(a) For $a_x = 1.2 \text{ m/s}^2$, $P = 91.5 \text{ N}$. (b) $a_x = -1.2 \text{ m/s}^2$, $P = 55.5 \text{ N}$

- 4.42 A 400-g block originally moving at 120 cm/s coasts 70 cm along a tabletop before coming to rest. What is the coefficient of friction between block and table?

▮ For the block $\sum F_y = 0$ yields $F_N = W = mg$ and $\sum F_x = ma$ yields $-\mu F_N = ma$; hence, $\mu = -a/g$. The uniform acceleration, from $v^2 - v_0^2 = 2ax$, is $a = -1.2^2/2(0.7) = -1.03 \text{ m/s}^2$; then $\mu = 1.03/9.8 = 0.105$.

- 4.43 How large a force parallel to a 30° incline is needed to give a 5.0-kg box an acceleration of 0.20 m/s^2 up the incline (a) if friction is negligible? (b) If the coefficient of friction is 0.30?

▮ (a) The component of the weight down the incline $= mg \sin 30^\circ = 5(9.8)(0.5) = 24.5 \text{ N}$, while the external force up the plane is F . So $F_{\text{net}} = ma$ becomes $F - 24.5 = 5(0.20)$ from which $F = 25.5 \text{ N}$ (b) A friction force $= \mu F_N$ must be added to 24.5 N down the incline. $F_N = mg \cos 30^\circ = 42.4 \text{ N}$ and $\mu F_N = 12.7 \text{ N}$, so F is larger by this amount; thus $F = 38.2 \text{ N}$.

- 4.44 An 8.0-kg box is released on a 30° incline and accelerates down the incline at 0.30 m/s^2 . Find the frictional force impeding its motion. How large is the coefficient of friction in this situation?

▮ The component of the weight down the incline $= 8(9.8)(0.5) = 39.2 \text{ N}$. Now $F = ma$ leads to $39.2 - f = 8(0.3)$, so that $f = 36.8 \text{ N}$. The normal force equals the component of W perpendicular to the incline, $8(9.8)(0.867) = 67.9 \text{ N}$. Therefore $\mu = 36.8/67.9 = 0.54$.

- 4.45 A horizontal force P is exerted on a 20-kg box in order to slide it up a 30° incline. The friction force retarding the motion is 80 N. How large must P be if the acceleration of the moving box is to be (a) zero and (b) 0.75 m/s^2 ?

▮ Here we choose the x axis along the incline with positive upward. All the forces on the block are shown in Fig. 4-8. From $\sum F_x = ma_x$, we have $P \cos 30^\circ - w \sin 30^\circ - f = ma_x$, where $m = 20 \text{ kg}$, $w = mg = 196 \text{ N}$, and $f = 80 \text{ N}$. (a) For $a_x = 0$, $P = 206 \text{ N}$. (b) For $a_x = 0.75 \text{ m/s}^2$, $P = 223 \text{ N}$

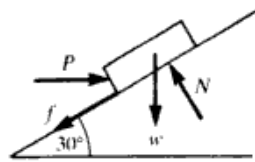

Fig. 4-8

- 4.46 A horizontal force of 200 N is required to cause a 15-kg block to slide up a 20° incline with an acceleration of 25 cm/s^2 . Find (a) the friction force on the block and (b) the coefficient of friction.

▮ The situation is as shown in Fig. 4-9. We again choose the x axis along the incline, and the y axis perpendicular to the incline. Then from $\sum F_x = ma_x$, we get $P \cos 20^\circ - f - w \sin 20^\circ = (15 \text{ kg})(0.25 \text{ m/s}^2)$ and from equilibrium in the y direction we get $N - P \sin 20^\circ - w \cos 20^\circ = 0$. Noting that $P = 200 \text{ N}$ and $w = mg = 147 \text{ N}$, we solve the equations, yielding $f = 134 \text{ N}$ and $N = 207 \text{ N}$, respectively. Finally $\mu_k = f/N = 0.65$ is the coefficient of friction. Note how P contributes to the normal force.

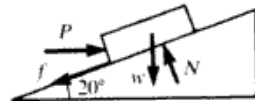

Fig. 4-9

- 4.47 What is the smallest force parallel to a 37° incline needed to keep a 100-N weight from sliding down the incline if the coefficients of static and kinetic friction are both 0.30?

▮ As usual, choose the x and y axes parallel and perpendicular to the incline. Let F be the unknown force, f the friction force, and N the normal force. If the weight is about to slide down the incline, then the frictional force is maximum and in the upward direction. Then

$$F - w \sin 37^\circ + f_{\text{max}} = 0, \quad \text{where} \quad f_{\text{max}} = \mu_s N \quad \text{and} \quad N - w \cos 37^\circ = 0.$$

Noting that $w = 100 \text{ N}$ and $\mu_s = 0.3$, we get $N = 80 \text{ N}$ and $f_{\text{max}} = 24 \text{ N}$; and finally $F = 36 \text{ N}$ is the minimum force needed along the incline.

- 4.48 Referring to Problem 4.47, indicate what parallel force is required to keep the weight moving up the incline at constant speed.

▮ Here we have kinetic friction down the incline, and $f = \mu_k N$. N is still 80 N (why?) and since $\mu_k = 0.30$, we have $f = 24$ N. Then $\sum F_x = 0$ yields $F - w \sin 37^\circ - f = 0$; and solving, we get $F = 84$ N.

- 4.49 For the same conditions as in Prob. 4.48 assume that the force F , up the incline, is 94 N. What is the acceleration of the object? If the object starts from rest, how far will it move in 10 s?

▮ As before, $f = \mu_k N = 24$ N and is down the incline opposing the motion. Then using $\sum F_x = ma_x$, we have $F - w \sin 37^\circ - f = ma_x$. Noting $m = w/g = 10.2$ kg we solve, getting $a_x = 0.98$ m/s² up the incline. Next we use the kinematic formula $x = v_{0x}t + \frac{1}{2}a_x t^2$, with $v_{0x} = 0$. Setting $t = 10$ s and using our a_x , we get $x = 49$ m.

- 4.50 A 5-kg block rests on a 30° incline. The coefficient of static friction between the block and incline is 0.20. How large a horizontal force must push on the block if the block is to be on the verge of sliding up the incline?

▮ Let P be the horizontal force. We choose x and y axes \parallel and \perp to the incline. Since the block is on the verge of moving, it is in equilibrium: $\sum F_x = 0$ and $\sum F_y = 0$. Here we have maximum static frictional force down the incline. $P \cos 30^\circ - w \sin 30^\circ - f_{\max} = 0$; $N - w \cos 30^\circ - P \sin 30^\circ = 0$, where N and f are the normal and friction forces, respectively. $w = mg = 49$ N. Substituting $f_{\max} = \mu_s N$ in the first equation, and putting in all known quantities, we get

$$0.866P - 0.20N = 24.5 \text{ N} \quad N - 0.50P = 42.4 \text{ N}$$

These two equations in two unknowns can be solved in a variety of ways. We multiply the first equation by 5 and add to the second equation to eliminate N . This yields $3.83P = 165$ N, or $P = 43.1$ N.

- 4.51 Rework Prob. 4.50 for incipient motion down the incline.

▮ The only difference from Prob. 4.50 is that the maximum frictional force is up the incline. We therefore change the sign in front of f_{\max} in the $\sum F_x = 0$ equation. We then get for our two equations:

$$0.866P + 0.20N = 24.5 \text{ N} \quad N - 0.50P = 42.4 \text{ N}$$

We again multiply the first equation by 5, but now subtract the second equation to eliminate N . This yields $4.83P = 80.1$ N, or $P = 16.6$ N. Note that in Probs. 4.50 and 4.51 the numerical values of N are different, reflecting their dependence on P .

- 4.52 In Fig. 4-10, the 8-kg object is subject to the forces $F_1 = 30$ N and $F_2 = 40$ N. Find the acceleration of the object.

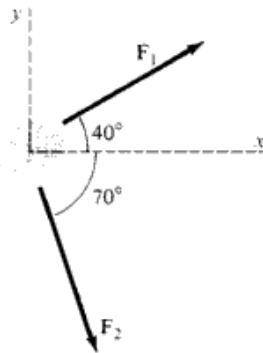

Fig. 4-10

▮ Newton's second law in component form is $F_{1x} + F_{2x} = ma_x$ and $F_{1y} + F_{2y} = ma_y$, or $30 \cos 40^\circ + 40 \cos 70^\circ = 8a_x$ and $30 \sin 40^\circ - 40 \sin 70^\circ = 8a_y$. Solving, $\mathbf{a} = 4.6\mathbf{i} - 2.3\mathbf{j}$ m/s².

- 4.53 A 7-kg object is subjected to two forces, $F_1 = 20\mathbf{i} + 30\mathbf{j}$ N and $F_2 = 8\mathbf{i} - 50\mathbf{j}$ N. Find the acceleration of the object.

▮ $\mathbf{F} = \mathbf{F}_1 + \mathbf{F}_2 = 28\mathbf{i} - 20\mathbf{j}$ N; $\mathbf{a} = \frac{1}{m}\mathbf{F} = 4\mathbf{i} - (20/7)\mathbf{j}$ m/s².

- 4.54 The forces F_1 and F_2 shown in Fig. 4-10 give the 8-kg object the acceleration $\mathbf{a} = 3.0\mathbf{i}$ m/s². Find F_1 and F_2 .

▮ Our motion equations take the form $F_{1x} + F_{2x} = 8(3)$, $F_{1y} + F_{2y} = 0$. From the latter, $F_1 \sin 40^\circ = F_2 \sin 70^\circ$; from the former, $F_1 \cos 40^\circ = 24 - F_2 \cos 70^\circ$. Dividing these relations we have $\tan 40^\circ = F_2 \sin 70^\circ / (24 - F_2 \cos 70^\circ)$. Using these, $F_2 = 16.4 \text{ N}$ and $F_1 = (\sin 70^\circ / \sin 40^\circ) F_2 = 24 \text{ N}$.

4.55 Find the force needed to give a proton ($m = 1.67 \times 10^{-27} \text{ kg}$) an acceleration $2 \times 10^9 \mathbf{i} - 3 \times 10^9 \mathbf{j} \text{ m/s}^2$.

▮ $\mathbf{F} = m\mathbf{a} = 3.34 \times 10^{-18} \mathbf{i} - 5.01 \times 10^{-18} \mathbf{j} \text{ N}$

4.56 A 200-g object is subjected to a force $0.30\mathbf{i} - 0.40\mathbf{j} \text{ N}$. If the object starts from rest, what will be the velocity vector of the object after 6 s?

▮ $\mathbf{v} = \mathbf{v}_0 + t\mathbf{a} = \mathbf{0} + \frac{t}{m} \mathbf{F} = \frac{6}{0.200} (0.30\mathbf{i} - 0.40\mathbf{j}) = 9\mathbf{i} - 12\mathbf{j} \text{ m/s}$

4.57 If the object of Prob. 4.56 started at the origin, what was its location at the end of the 6-s period?

▮ $\mathbf{s} = \mathbf{s}_0 + t\mathbf{v}_0 + \frac{1}{2}t^2\mathbf{a} = \mathbf{0} + \mathbf{0} + \frac{t^2}{2m} \mathbf{F} = \frac{36}{2(0.200)} (0.30\mathbf{i} - 0.40\mathbf{j}) = 27\mathbf{i} - 36\mathbf{j} \text{ m}$

Thus the object was found at the point $(27 \text{ m}, -36 \text{ m})$.

4.3 TWO-OBJECT AND OTHER PROBLEMS

4.58 In Fig. 4-11, find the acceleration of the cart that is required to prevent block B from falling. The coefficient of static friction between the block and the cart is μ_s .

▮ If the block is not to fall, the friction force, f , must balance the block's weight: $f = mg$. But the horizontal motion of the block is given by $N = ma$. Therefore,

$$\frac{f}{N} = \frac{g}{a} \quad \text{or} \quad a = \frac{g}{f/N}$$

Since the maximum value of f/N is μ_s , we must have $a \geq g/\mu_s$, if the block is not to fall.

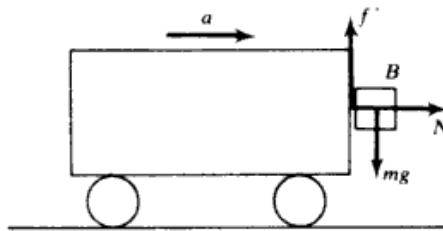

Fig. 4-11

4.59 A passenger on a large ship sailing in a quiet sea hangs a ball from the ceiling of her cabin by means of a long thread. Whenever the ship accelerates, she notes that the pendulum ball lags behind the point of suspension and so the pendulum no longer hangs vertically. How large is the ship's acceleration when the pendulum stands at an angle of 5° to the vertical?

▮ See Fig. 4-12. The ball is accelerated by the force $T \sin 5^\circ$. Therefore $T \sin 5^\circ = ma$. Vertically $\sum F = 0$, so $T \cos 5^\circ = mg$. Solving for $a = g \tan 5^\circ$ gives $a = 0.0875g = 0.86 \text{ m/s}^2$.



Fig. 4-12

4.60 A rectangular block of mass m sits on top of another similar block, which in turn sits on a flat table. The maximum possible frictional force of one block on the other is $2.0m \text{ N}$. What is the largest possible acceleration which can be given the lower block without the upper block sliding off? What is the coefficient of friction between the two blocks?

▮ $F_{\text{max}} = 2.0m = ma_{\text{max}}$, so $a_{\text{max}} = 2.0 \text{ m/s}^2$. Also $\mu = f/mg = 2.0m/9.8m = 0.20$.

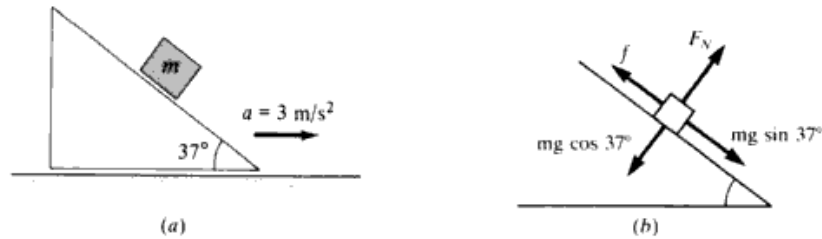

Fig. 4-13

- 4.61 A block sits on an incline as shown in Fig. 4-13(a). (a) What must be the frictional force between block and incline if the block is not to slide along the incline when the incline is accelerating to the right at 3 m/s^2 ? (b) What is the least value μ_s can have for this to happen?

▮ Resolve the forces and the 3-m/s^2 acceleration into components perpendicular and parallel to the plane [Fig. 4-13(b)]. Write $F = ma$ for each direction: $0.6mg - f = 3(0.8)m$ and $F_N - 0.8mg = 3(0.6)m$, which yield (a) $f = (3.48m) \text{ N}$, $F_N = (9.64m) \text{ N}$

$$(b) \mu_s = \frac{f}{F_N} = \frac{3.48m}{9.64m} = 0.36$$

- 4.62 In the absence of friction, would the block of Prob. 4.61 accelerate up or down the incline?
 ▮ Down [at 3.48 m/s^2 relative to incline, since total acceleration down incline is then $0.6g$ by Prob. 4.61(a)].
- 4.63 The inclined plane shown in Fig. 4-14 has an acceleration \mathbf{a} to the right. Show that the block will slide on the plane if $a > g \tan(\theta - \alpha)$, where $\mu_s = \tan \theta$ is the coefficient of static friction for the contacting surfaces.

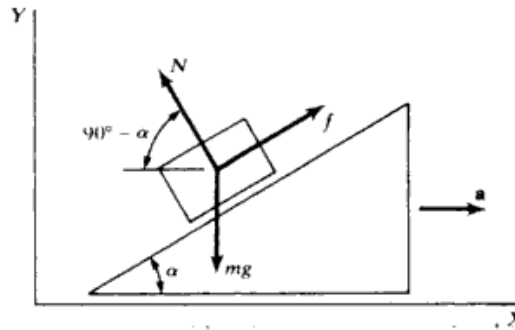

Fig. 4-14

▮ If the block is not to slide, it must have the same acceleration as the plane. Hence

$$f \cos \alpha - N \sin \alpha = ma \quad f \sin \alpha + N \cos \alpha - mg = 0$$

From these,

$$f = m(a \cos \alpha + g \sin \alpha) \quad N = m(g \cos \alpha - a \sin \alpha)$$

and

$$\frac{f}{N} = \frac{a \cos \alpha + g \sin \alpha}{g \cos \alpha - a \sin \alpha} = \frac{a + g \tan \alpha}{g - a \tan \alpha}$$

Now the maximum value of f/N in the absence of slipping is $\mu_s = \tan \theta$. Thus the acceleration a must satisfy

$$\frac{a + g \tan \alpha}{g - a \tan \alpha} \leq \tan \theta \quad \text{or} \quad a \leq g \frac{\tan \theta - \tan \alpha}{1 + \tan \theta \tan \alpha} = g \tan(\theta - \alpha)$$

If $a > g \tan(\theta - \alpha)$, the block will slide.

- 4.64 Objects A and B , each of mass m , are connected by a light inextensible cord. They are constrained to move on a frictionless ring in a vertical plane, as shown in Fig. 4-15. The objects are released from rest at the positions shown. Find the tension in the cord just after release.

▮ At the moment of release, A is constrained to move horizontally and B vertically, so that the two initial

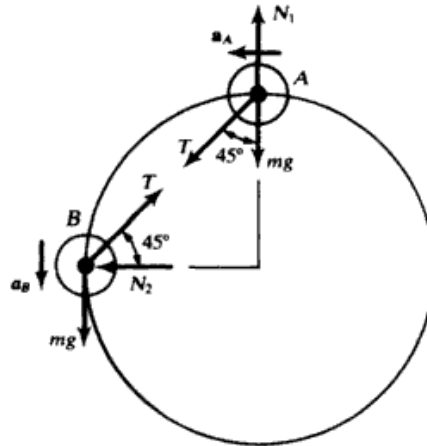

Fig. 4-15

accelerations are tangential as shown. Furthermore, the two accelerations have the same magnitude, a , since otherwise the cord would have to stretch. Thus, the horizontal force equation for A and the vertical force equation for B , at the indicated positions, are

$$T \sin 45^\circ = ma \quad mg - T \sin 45^\circ = ma$$

Eliminating a ,

$$T = \frac{mg}{2 \sin 45^\circ} = \frac{mg}{\sqrt{2}}$$

4.65 If the system in Fig. 4-16(a) is given an acceleration, find the forces on the sphere, assuming no friction.

▮ From Fig. 4-16(b), $\sum F_{\text{ver}} = R_1 \cos 30^\circ - w = ma_{\text{ver}} = 0$ and $\sum F_{\text{hor}} = R_2 - R_1 \sin 30^\circ = ma$. Thus, the acting forces are

$$R_1 = \frac{w}{\cos 30^\circ} = 1.15w \quad R_2 = R_1 \sin 30^\circ + \frac{w}{g}a = (1.15w)(0.5) + \frac{w}{g}a = w\left(0.58 + \frac{a}{g}\right)$$

and the weight, w .

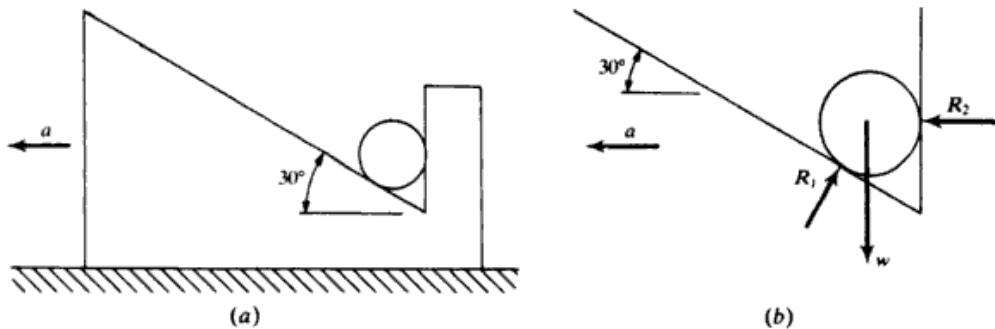

Fig. 4-16

4.66 In Fig. 4-17, mass A is 15 kg and mass B is 11 kg. If they are given an upward acceleration of 3 m/s^2 by pulling up on A , find the tensions T_1 and T_2 .

▮ First apply Newton's second law to the system as a whole to find the force F_1 accelerating both masses upward.

$$F_1 = (m_A + m_B)a = (15 + 11)3 \quad F_1 = 78 \text{ N}$$

Since F_1 is the resultant force, $F_1 = T_1 - m_Ag - m_Bg$, and the tension T_1 is the sum of the weights of A and B plus F_1 .

$$T_1 = m_Ag + m_Bg + F_1 = 15(9.8) + 11(9.8) + 78 = 147 + 107.8 + 78 \quad T_1 = \underline{332.8 \text{ N}}$$

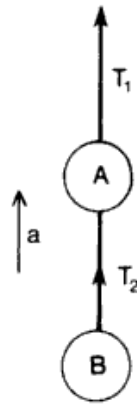

Fig. 4-17

Similarly for mass *B* only,

$$F_2 = m_B a = 11(3) = 33 \text{ N} \quad T_2 = m_B g + F_2 = 11(9.8) + 33 = 107.8 + 33 = \underline{140.8 \text{ N}}$$

To check, for block *A* only,

$$T_1 = m_A g + m_A a + T_2 = 147 + 45 + 140.8 = \underline{332.8 \text{ N}}$$

- 4.67 Referring to Fig. 4-18, find the acceleration of the blocks and the tension in the connecting string if the applied force is *F* and the frictional forces on the blocks are negligible.

▮ Apply $F = ma$ to each block in turn to obtain $F - T = m_2 a$ and $T = m_1 a$. Solve for *T* and *a* to obtain $a = F / (m_1 + m_2)$ and $T = m_1 F / (m_1 + m_2)$.

- 4.68 In Fig. 4-18, if $F = 20 \text{ N}$, $m_1 = m_2 = 3 \text{ kg}$, and the acceleration is 0.50 m/s^2 , what will be the tension in the connecting cord if the frictional forces on the two blocks are equal? How large is the frictional force on either block?



Fig. 4-18

▮ Write $F = ma$ for each block using *f* as the friction force on each block. Then we obtain $F - f - T = m_2 a$ and $T - f = m_1 a$. Use the given values and solve to find $T = 10 \text{ N}$ and $f = 8.5 \text{ N}$.

- 4.69 The device diagramed in Fig. 4-19 is called an *Atwood's machine*. In terms of m_1 and m_2 with $m_2 > m_1$, (a) how far will m_2 fall in time *t* after the system is released? (b) What is the tension in the light cord that connects the two masses? Assume the pulley to be frictionless and massless.

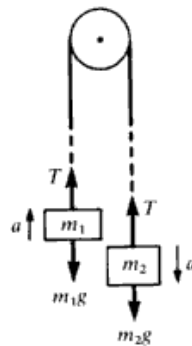

Fig. 4-19

▮ (a) Isolate the forces on each mass and write Newton's second law, choosing *up* as positive: $T - m_1 g = m_1 a$ and $T - m_2 g = -m_2 a$. Eliminating *T* gives $a = (m_2 - m_1)g / (m_1 + m_2)$. Now use $y = at^2/2$ to find the distance fallen in time *t*. (b) From the above equations, $T = 2m_1 m_2 g / (m_1 + m_2)$.

- 4.70** A cord passing over a frictionless, massless pulley (Atwood's machine) has a 4-kg block tied to one end and a 12-kg block tied to the other. Compute the acceleration and the tension in the cord.

▮ Using the formulas derived in Prob. 4.69,

$$a = \frac{12 - 4}{12 + 4}(9.8) = 4.9 \text{ m/s}^2 \quad T = \frac{2(4)(12)}{4 + 12}(9.8) = 58.8 \text{ N}$$

- 4.71** For an Atwood's machine (Prob. 4.69) with masses 10 and 12 kg, find (a) the velocities at the end of 3 s and (b) the distances moved in 3 s. (c) If at the end of 3 s the string is cut, find the distances moved by the masses in the next 6 s.

▮ (a)
$$a = \frac{(m_2 - m_1)g}{m_1 + m_2} = \frac{12 - 10}{12 + 10}(9.8) = 0.89 \text{ m/s}^2$$

Since the acceleration is constant, the common speed at the end of 3 s is $v = v_0 + at = 0 + (0.89)(3) = 2.67 \text{ m/s}$. Mass 2 moves down and mass 1 moves up. (b) The distance moved by each mass in 3 s is

$$s = v_0 t + \frac{1}{2}at^2 = (0)(3) + \frac{1}{2}(0.89)(3)^2 = 4 \text{ m.}$$

(c) If the string is cut, the masses fall freely with initial velocities $v_{20} = -2.67 \text{ m/s}$ and $v_{10} = +2.67 \text{ m/s}$, with up taken as positive. For mass 2, the displacement in 6 s is then

$$y_2 = v_{20}t - \frac{1}{2}gt^2 = (-2.67)(6) - \frac{1}{2}(9.8)(6)^2 = -192.4 \text{ m}$$

i.e., a downward distance of 192.4 m. Mass 1 travels upward a distance

$$d' = \frac{v_{10}^2}{2g} = \frac{(2.67)^2}{2(9.8)} = 0.4 \text{ m}$$

before coming to a stop and then falling downward. The time of travel upward before coming to a stop for mass 1 is

$$t_{\text{up}} = \frac{v_{10}}{g} = \frac{2.67}{9.8} = 0.27 \text{ s}$$

It then travels downward 5.73 s for a distance

$$d'' = \frac{1}{2}(-g)t^2 = \frac{1}{2}(9.8)(5.73)^2 = 160.9 \text{ m.}$$

The total distance traveled by mass 1 is then $d = d' + d'' = 0.4 + 160.9 = 161.3 \text{ m}$.

- 4.72** In Fig. 4-20, the weights of the objects are 200 and 300 N. The pulleys are essentially frictionless and massless. Pulley P_1 has a stationary axle but pulley P_2 is free to move up and down. Find the tensions T_1 and T_2 , and the acceleration of each body.

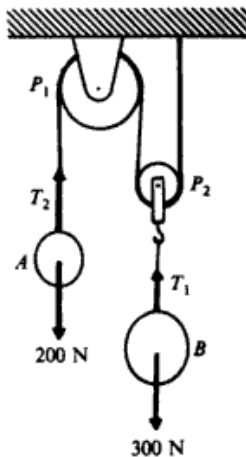

Fig. 4-20

Mass B will rise and mass A will fall. You can see this by noting that the forces acting on pulley P_2 are $2T_2$ up and T_1 down. Therefore $T_1 = 2T_2$ (the inertialess object transmits the tension). Twice as large a force is pulling upward on B as on A .

Let $a =$ downward acceleration of A . Then $\frac{1}{2}a =$ upward acceleration of B . [As the cord between P_1 and A lengthens by 1 unit, the segments on either side of P_2 each shorten by $\frac{1}{2}$ unit. Hence, $\frac{1}{2} = s_B/s_A = (\frac{1}{2}a_B t^2)/(\frac{1}{2}a_A t^2) = a_B/a_A$.] Write $\sum F_y = ma_y$ for each mass in turn, taking the direction of motion as positive in each case. We have

$$T_1 - 300 \text{ N} = m_B(\frac{1}{2}a) \quad \text{and} \quad 200 \text{ N} - T_2 = m_A a$$

But $m = w/g$ and so $m_A = (200/9.8) \text{ kg}$ and $m_B = (300/9.8) \text{ kg}$. Further, $T_1 = 2T_2$. Substitution of these values in the two equations allows us to compute T_2 and then T_1 and a . The results are

$$T_1 = \underline{327 \text{ N}} \quad T_2 = \underline{164 \text{ N}} \quad a = \underline{1.78 \text{ m/s}^2}$$

- 4.73 An inclined plane making an angle of 25° with the horizontal has a pulley at its top. A 30-kg block on the plane is connected to a freely hanging 20-kg block by means of a cord passing over the pulley. Compute the distance the 20-kg block will fall in 2 s starting from rest. Neglect friction.

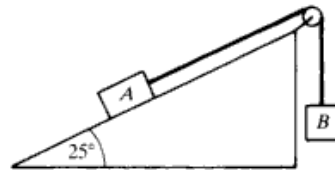

Fig. 4-21

The situation is as shown in Fig. 4-21. We apply Newton's second law to each block separately. For block B we choose downward as positive, while for block A we choose our x axis along the incline with the positive sense upward. This choice allows us to use the same symbol, a , for the acceleration of each block. Then for block B , $w_b - T = m_b a$, where $m_b = 20 \text{ kg}$ and $w_b = 196 \text{ N}$ and T is the tension in the cord. Since the pulley is frictionless, the same tension T will exist on both sides of the pulley. Then for block A , $T - w_a \sin 25^\circ = m_a a$, where $m_a = 30 \text{ kg}$ and $w_a = 294 \text{ N}$. We can eliminate the tension T by adding the two equations, which yields $w_b - w_a \sin 25^\circ = (m_a + m_b)a$. Substituting in the known values we solve, getting $a = \underline{1.44 \text{ m/s}^2}$. The equation for fall from rest is $y = v_{0y}t + \frac{1}{2}a_y t^2$, with $v_{0y} = 0$. Substituting in $a_y = 1.44 \text{ m/s}^2$ and $t = 2 \text{ s}$, we get $y = \underline{2.88 \text{ m}}$.

- 4.74 Repeat Prob. 4.73 if the coefficient of friction between block and plane is 0.20.

The equation for block A is now $T - w_a \sin 25^\circ - f = m_a a$. The block B equation is the same as before: $w_b - T = m_b a$. Adding the two equations we get this time $w_b - w_a \sin 25^\circ - f = (m_a + m_b)a$. As soon as we obtain f we can solve for a . To obtain f we note that $f = \mu_k N$, where $\mu_k = 0.20$ is the coefficient of kinetic friction and N is the normal force exerted on the block by the incline. Noting $\sum F_y = 0$ for the direction perpendicular to the incline, we have $w_a \cos 25^\circ - N = 0$, or $N = 266 \text{ N}$. Then $f = 53 \text{ N}$ and solving for the acceleration $a = \underline{0.38 \text{ m/s}^2}$. Again using $y = v_{0y}t + \frac{1}{2}a_y t^2$ with $v_{0y} = 0$, $a_y = 0.38 \text{ m/s}^2$, and $t = 2 \text{ s}$, we get $y = \underline{0.76 \text{ m}}$.

- 4.75 In Fig. 4-22, the two boxes have identical masses, 40 kg. Both experience a sliding friction force with $\mu = 0.15$. Find the acceleration of the boxes and the tension in the tie cord.

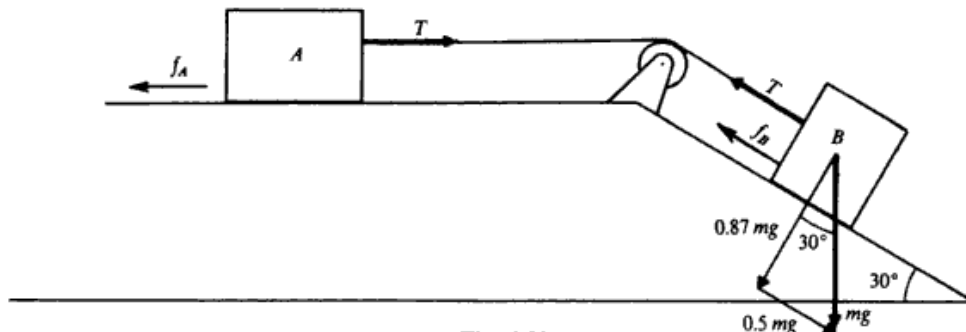

Fig. 4-22

Using $f = \mu Y$, where $Y =$ normal force, we find that the friction forces on the two boxes are

$$f_A = (0.15)(mg) \quad f_B = (0.15)(0.87 mg)$$

But $m = 40$ kg and so $f_A = 59$ N and $f_B = 51$ N.

Let us apply $\sum F_x = ma_x$ to each block in turn, taking the direction of motion as positive.

$$T - 59 \text{ N} = (40 \text{ kg})a \quad \text{and} \quad 0.5 mg - T - 51 \text{ N} = (40 \text{ kg})a$$

Solving these two equations for a and T gives $a = 1.08 \text{ m/s}^2$ and $T = 102 \text{ N}$.

- 4.76 Two bodies, of masses m_1 and m_2 , are released from the position shown in Fig. 4.23(a). If the mass of the smooth-topped table is m_3 , find the reaction of the floor on the table while the two bodies are in motion. Assume that the table does not move.

From Fig. 4-23(b), the force equations for the bodies are

Body 1: $\sum F_{\text{ver}} = w_1 - T = m_1 a$

Body 2: $\sum F_{\text{hor}} = T = m_2 a$

Table: $\sum F_{\text{ver}} = N - T - w_2 - w_3 = 0, \sum F_{\text{hor}} = T - f = 0$

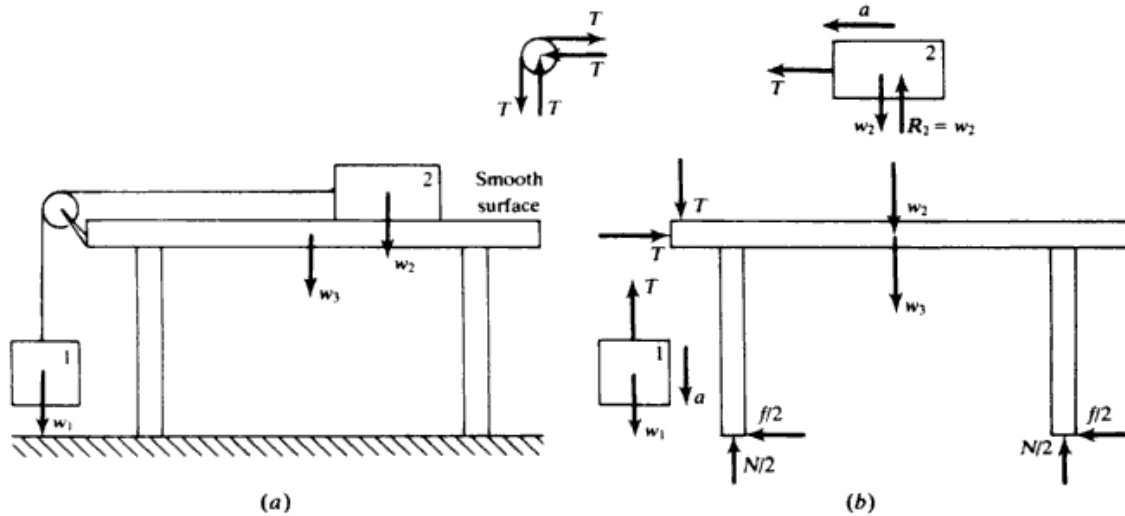

Fig. 4-23

where N and f are the vertical and horizontal (frictional) components of the force exerted by the floor on the table. [We assume in Fig. 4.23(b) that left and right legs share load equally. This does not affect our analysis.]

From the first two equations,

$$a = \frac{w_1}{m_1 + m_2} = \frac{m_1 g}{m_1 + m_2}$$

Then,

$$f = T = m_2 a = \frac{m_1 m_2 g}{m_1 + m_2}$$

and, finally,

$$N = T + m_2 g + m_3 g = \left(\frac{m_1 m_2}{m_1 + m_2} + m_2 + m_3 \right) g$$

- 4.77 Three identical blocks, each of mass 0.6 kg, are connected by light strings as shown in Fig. 4-24. Assume that they lie on a smooth, horizontal surface and are observed to have an acceleration of 4.0 m/s^2 under the action of a force F . Calculate F and the two tensions.

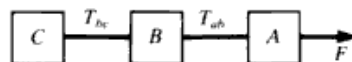

Fig. 4-24

Let the tensions in the cord be T_{ab} and T_{bc} , respectively, and let us write Newton's second law for each block separately, choosing positive to the right for each. Since the cords are inextensible, we know that they

have the same acceleration, which we denote by a . Then for blocks A , B , C , respectively (letting $m = m_a = m_b = m_c$),

$$F - T_{ab} = ma \quad T_{ab} - T_{bc} = ma \quad T_{bc} = ma$$

(Note how the tensions appear with opposite signs in adjacent equations.) To solve these equations for a we add the equations, and the tensions cancel in pairs, leaving $F = 3ma = 3(0.6 \text{ kg})(4.0 \text{ m/s}^2) = 7.2 \text{ N}$. The tensions can now be obtained by substituting back into the individual equations:

$$T_{ab} = 7.2 \text{ N} - (0.6 \text{ kg})(4.0 \text{ m/s}^2) = 4.8 \text{ N} \quad T_{bc} = (0.6 \text{ kg})(4.0 \text{ m/s}^2) = 2.4 \text{ N}$$

- 4.78 Three blocks with masses 6 kg, 9 kg, and 10 kg are connected as shown in Fig. 4-25. The coefficient of friction between the table and the 10-kg block is 0.2. Find (a) the acceleration of the system and (b) the tensions in the cord on the left and in the cord on the right.

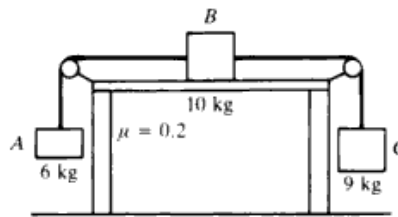

Fig. 4-25

| (a) Let the tension in the cord on the left be T_1 and on the right be T_2 . The pulleys are assumed to be frictionless. We apply Newton's second law to each of the three blocks, choosing the positive sense of the axis for each block consistently. Thus we choose downward as positive for block C , to the right positive for block B , and upward as positive for block A . The frictional force on block B is to the left and can be obtained from $f = \mu_k N$, where $\mu_k = 0.20$ and the normal force N equals the weight $w_b = 98 \text{ N}$ from vertical equilibrium. Thus $f = 19.6 \text{ N}$. For our three equations we have

$$w_c - T_2 = m_c a$$

where a is the acceleration, $m_c = 9 \text{ kg}$, and $w_c = 88.2 \text{ N}$.

$$T_2 - T_1 - f = m_b a$$

$$T_1 - w_a = m_a a$$

where $m_a = 6 \text{ kg}$ and $w_a = 58.8 \text{ N}$.

As with earlier problems involving cords connecting blocks, the tensions in adjacent equations appear with opposite signs. Adding the three equations eliminates the tensions completely: $w_c - f - w_a = (m_a + m_b + m_c)a$. Note that this is equivalent to a one-dimensional problem involving a single block of mass $m_a + m_b + m_c$ acted on by a force w_c to the right and forces f and w_a to the left. Substituting the known masses, weights, and f gives $a = 0.39 \text{ m/s}^2$. (b) Substitute a back into the equations of motion for each block, most conveniently the first and third, to obtain $T_1 = 61 \text{ N}$, $T_2 = 85 \text{ N}$. The remaining equation can be used to check the results.

- 4.79 In Fig. 4-26, the coefficient of sliding friction between block A and the table is 0.20. Also, $m_A = 25 \text{ kg}$, $m_B = 15 \text{ kg}$. How far will block B drop in the first 3 s after the system is released?

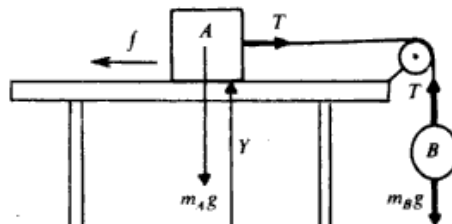

Fig. 4-26

▮ Since, for block A , there is no motion vertically, the normal force is $Y = m_A g = (25 \text{ kg})(9.8 \text{ m/s}^2) = 245 \text{ N}$. Then $f = \mu Y = (0.20)(245 \text{ N}) = 49 \text{ N}$.

We must first find the acceleration of the system and then we can describe its motion. Let us apply $F = ma$ to each block in turn. Taking the motion direction as positive, we have

$$T - f = m_A a \quad \text{or} \quad T - 49 \text{ N} = (25 \text{ kg})a$$

and

$$m_B g - T = m_B a \quad \text{or} \quad -T + (15)(9.8) \text{ N} = (15 \text{ kg})a$$

We can eliminate T by adding the two equations. Then, solving for a , we find $a = 2.45 \text{ m/s}^2$.

Now we can work a motion problem with $a = 2.45 \text{ m/s}^2$, $v_0 = 0$, $t = 3 \text{ s}$.

$$y = v_0 t + \frac{1}{2} a t^2 \quad \text{gives} \quad y = 0 + \frac{1}{2} (2.45 \text{ m/s}^2) (3 \text{ s})^2 = \underline{11.0 \text{ m}}$$

as the distance B falls in the first 3 s.

- 4.80** How large a horizontal force in addition to T must pull on block A in Fig. 4-26 to give it an acceleration of 0.75 m/s^2 toward the left? Assume, as in Prob. 4.79, that $\mu = 0.20$, $m_A = 25 \text{ kg}$, and $m_B = 15 \text{ kg}$.

▮ If we were to redraw Fig. 4-26 in this case, we should show a force P pulling toward the left on A . In addition, the retarding friction force f should be reversed in direction in the figure. As in Prob. 4.79, $f = 49 \text{ N}$.

We write $F = ma$ for each block in turn, taking the motion direction to be positive. We have

$$P - T - 49 \text{ N} = (25 \text{ kg})(0.75 \text{ m/s}^2) \quad \text{and} \quad T - (15)(9.8) \text{ N} = (15 \text{ kg})(0.75 \text{ m/s}^2)$$

Solve the last equation for T and substitute in the previous equation. We can then solve for the single unknown, P , and find it to be 226 N.

- 4.81** The two blocks shown in Fig. 4-27 have equal masses. The coefficients of static and dynamic friction are equal, 0.30 for both blocks. If the system is given an initial speed of 0.90 m/s to the left, how far will it move before coming to rest if the inclines are quite long?

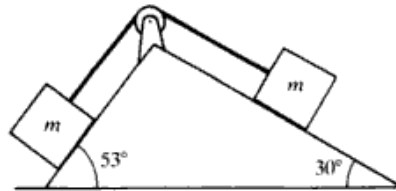

Fig. 4-27

▮ Again we assume that the pulley is frictionless and the tension in the cord is the same everywhere. We apply Newton's second law to each block to get the acceleration of the blocks. We choose our x axis for each block \parallel to the inclines and choose the positive sense to the left. Then we have $w \sin 53^\circ - f_a - T = ma$ and $T - w \sin 30^\circ - f_b = ma$, where m is the common mass and $w = mg$, the common weights of blocks A and B . The frictional forces on the two blocks are determined from the equilibrium conditions perpendicular to the inclines. Thus for block A , $f_a = \mu_k N_a$, with normal force $N_a = w \cos 53^\circ$; and for block B , $f_b = \mu_k N_b$, with $N_b = w \cos 30^\circ$. We eliminate the tension by adding our two equations to yield $w \sin 53^\circ - f_a - f_b - w \sin 30^\circ = 2ma$; or substituting for w , f_a , and f_b , $mg \sin 53^\circ - \mu_k mg \cos 53^\circ - \mu_k mg \cos 30^\circ - mg \sin 30^\circ = 2ma$. Dividing out by m and solving, we get $a = g(\sin 53^\circ - \mu_k \cos 53^\circ - \mu_k \cos 30^\circ - \sin 30^\circ)/2 = \underline{-0.694 \text{ m/s}^2}$. We now apply the kinematical equation $v_x^2 = v_{0x}^2 + 2a_x x$ to either block with $v_{0x} = 0.90 \text{ m/s}$, $a_x = -0.694 \text{ m/s}^2$, and $v_x = 0$ to get $x = \underline{0.583 \text{ m}}$.

- 4.82** If the blocks in Fig. 4-27 are momentarily at rest, what is the smallest coefficient of friction for which the blocks will remain at rest?

▮ The tendency to motion will be to the left since that slope is steeper. For minimum coefficient of friction the frictional forces will be their maximum value (the verge of slipping). Thus, $f_a = \mu_s mg \cos 53^\circ$ and $f_b = \mu_s mg \cos 30^\circ$, both acting to the right. Then the equations of equilibrium are
 Block A: $mg \sin 53^\circ - \mu_s mg \cos 53^\circ - T = 0$. Block B: $T - mg \sin 30^\circ - \mu_s mg \cos 30^\circ = 0$
 Adding the two equations yields $mg(\sin 53^\circ - \mu_s \cos 53^\circ - \sin 30^\circ - \mu_s \cos 30^\circ) = 0$. Dividing out mg and rearranging terms, we get $\mu_s(\cos 53^\circ + \cos 30^\circ) = \sin 53^\circ - \sin 30^\circ$, and $\mu_s = \underline{0.203}$.

- 4.83 A blimp is descending with an acceleration a . How much ballast must be jettisoned for the blimp to rise with the same acceleration a ? There is a buoyant force acting upward on the blimp which is equal to the weight of the air displaced by the blimp; assume that the buoyant force is the same in both cases.

▮ From Fig. 4-28, the equations of motion are

Descending: $m_1g - F_b = m_1a$. Ascending: $F_b - m_2g = m_2a$

Adding gives $(m_1 - m_2)g = (m_1 + m_2)a$. But $m_1 - m_2 = m$, the mass of the discarded ballast. Therefore,

$$mg = [m_1 + (m_1 - m)]a \quad \text{or} \quad m = \left(\frac{2a}{g + a}\right)m_1$$

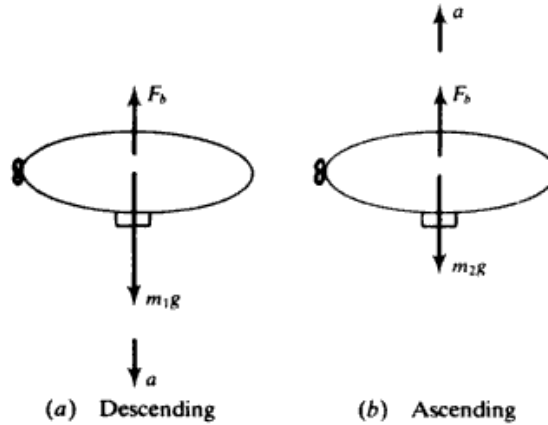

Fig. 4-28

- 4.84^c Show that the acceleration of the center of mass in Prob. 4.83 does not change when the ballast is ejected. Use this fact to confirm the value of m found in Prob. 4.83.

▮ Choose *up* as positive. Since $\Sigma \mathbf{F}$ on the system of blimp and ballast is the same before and after the ballast was thrown out, $\Sigma \mathbf{F} = m_1 a_{cm}$, we must have $a_{cm} = -a$, before and after. Now, measured from some reference level, $y_{cm} = [m_2 y_{blimp} + (m_1 - m_2) y_{ballast}] / m_1$. Then $\ddot{y}_{cm} = [m_2 \ddot{y}_{blimp} + (m_1 - m_2) \ddot{y}_{ballast}] / m_1$. But $\ddot{y}_{blimp} = a$, $\ddot{y}_{ballast} = -g$, and $\ddot{y}_{cm} = a_{cm} = -a$; so $-a = [m_2 a - (m_1 - m_2)g] / m_1$, or $(m_1 + m_2)a = (m_1 - m_2)g$ as before, yielding the same value for $m \equiv (m_1 - m_2)$.

- 4.85 Three blocks, of masses 2.0, 4.0, and 6.0 kg, arranged in the order lower, middle, and upper, respectively, are connected by strings on a frictionless inclined plane of 60° . A force of 120 N is applied upward along the incline to the uppermost block, causing an upward movement of the blocks. The connecting cords are light. What is the acceleration of the blocks?

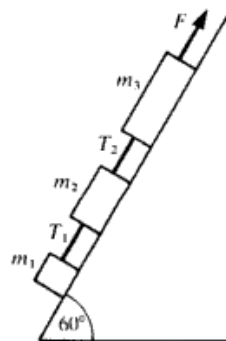

Fig. 4-29

▮ The situation is depicted in Fig. 4-29 with $F = 120$ N.

$$m_1 = 2.0 \text{ kg} \quad m_2 = 4.0 \text{ kg} \quad \text{and} \quad m_3 = 6.0 \text{ kg}$$

Applying Newton's second law to each block, we have

$$F - T_2 - m_3 g \sin 60^\circ = m_3 a \quad T_2 - T_1 - m_2 g \sin 60^\circ = m_2 a \quad T_1 - m_1 g \sin 60^\circ = m_1 a$$

Adding these equations, $F - (m_1 + m_2 + m_3)g \sin 60^\circ = (m_1 + m_2 + m_3)a$; $120 \text{ N} - (12.0 \text{ kg})(9.8 \text{ m/s}^2)(0.866) = (12.0 \text{ kg})a$; $a = \underline{1.51 \text{ m/s}^2}$.

- 4.86** Refer to Prob. 4.85. What are the tensions between the upper and middle blocks, and the lower and middle blocks?

| Continuing from Prob. 4.85, substitute the value of a into the individual block equations, and solve for T_1 and T_2 .

For block 1: $T_1 = (2.0 \text{ kg})(9.8 \text{ m/s}^2)(0.866) + (2.0 \text{ kg})(1.51 \text{ m/s}^2) = \underline{20.0 \text{ N}}$

For block 3: $T_2 = 120 \text{ N} - (6.0 \text{ kg})(9.8 \text{ m/s}^2)(0.866) - (6.0 \text{ kg})(1.51 \text{ m/s}^2) = \underline{60.0 \text{ N}}$

This can be checked by substituting into the equation for block 2.

- 4.87** A skier goes down a hillside, which makes an angle θ with respect to the horizontal. If μ_k is the coefficient of sliding friction between skis and slope, show that the acceleration of the skier is $a = g(\sin \theta - \mu_k \cos \theta)$.

| Reverse the direction of motion in Prob. 4.23, and apply to kinetic rather than static friction.

- 4.88** Refer to Fig. 4-30. Find T_1 and T_2 if the blocks are to accelerate (**a**) upward at 6.0 m/s^2 and (**b**) downward at 0.60 m/s^2 .

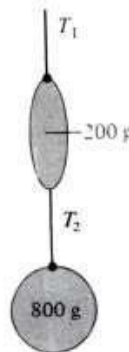

Fig. 4-30

| Treating the two masses and the connecting cord as an isolated object, $T_1 - 1.0g = 1.0a$; then isolating the 800-g mass, obtain $T_2 - 0.8g = 0.8a$; a is the same in both expressions. (**a**) $a = 6.0 \text{ m/s}^2$, so $T_1 = 6.0 + 9.8 = \underline{15.8 \text{ N}}$ and $T_2 = \underline{12.6 \text{ N}}$. (**b**) $a = -0.60 \text{ m/s}^2$, so $T_1 = 9.8 - 0.6 = \underline{9.2 \text{ N}}$ and $T_2 = \underline{7.4 \text{ N}}$. As a check on the answers, isolate the 200-g mass and observe that $T_1 - 0.2g - T_2 = 0.2a$.

- 4.89** The cords holding the two masses shown in Fig. 4-30 will break if the tension exceeds 15.0 N . What is the maximum upward acceleration one can give the masses without the cord breaking? Repeat if the strength is only 7.0 N .

| Note, $T_1 > T_2$ from Prob. 4.88. Consider the free body made up of both masses and the massless cord between them: $T_1 - 1.0g = 1.0a$; for $T_1 = 15.0 \text{ N}$, $a = \underline{5.2 \text{ m/s}^2}$; for $T_1 = 7.0 \text{ N}$, $a = \underline{-2.8 \text{ m/s}^2}$. (The system must be accelerating downward, since T_1 could not support the 9.8-N weight.)

- 4.90** A 6.0-kg block rests on a smooth frictionless table. A string attached to the block passes over a frictionless pulley, and a 3.0-kg mass hangs from the string as shown in Fig. 4-31. (**a**) What is the acceleration a ? (**b**) What is the tension T in the string?

| (**a**) This type of problem, as seen in Prob. 4.78, can be treated as if it were in one dimension. Thus, Newton's second law takes the form

$$F = ma \quad m_2g = (m_1 + m_2)a \quad 3(9.8) = (6 + 3)a \quad 29.4 = 9a \quad a = \underline{3.27 \text{ m/s}^2}$$

(**b**) Applying Newton's second law to mass m_1 alone,

$$T = m_1a = 6(3.27) = \underline{19.6 \text{ N}}$$

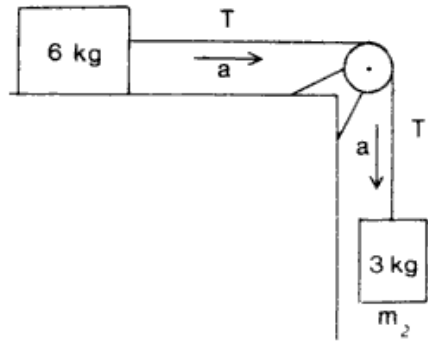

Fig. 4-31

To check this, apply Newton's second law to m_2 alone.

$$m_2g - T = m_2a \quad 3(9.8) - T = 3(3.27) \quad 29.4 - T = 9.8 \quad T = \underline{19.6 \text{ N}}$$

As expected, the tension is the same.

- 4.91** A 6.0-kg block rests on a horizontal surface. Its coefficient of kinetic friction is 0.22. The block is connected by a string passing over a pulley to a 3.0-kg mass, as in Fig. 4-32. (a) What is the acceleration a ? (b) What is the tension T in the string?

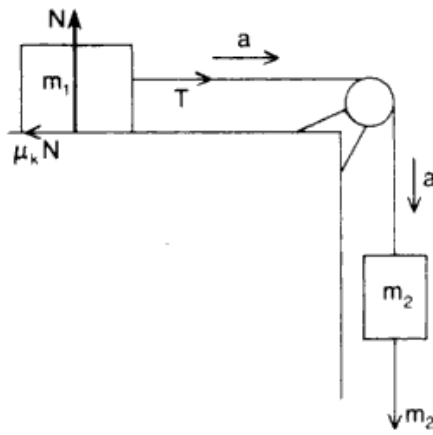

Fig. 4-32

▮ We treat the problem as if it were in one dimension.

(a) For the system as a whole,

$$\begin{aligned} \text{net } F = ma & \quad m = m_1 + m_2 = 6.0 + 3.0 = 9.0 \text{ kg} & \quad \text{net } F = m_2g - \mu_k N = ma & \quad N = m_1g \\ ma = m_2g - \mu_k m_1g & \quad 9.0a = 3.0(9.8) - 0.22(6.0)(9.8) = 1.68(9.8) & \quad a = \underline{1.83 \text{ m/s}^2} \end{aligned}$$

(b) The force the string exerts on m_1 is

$$T = \mu_k N + m_1a = 0.22(6.0)(9.8) + 6.0(1.83) = 12.94 + 10.98 \quad T = \underline{23.9 \text{ N}}$$

- 4.92** Suppose that blocks A and B have masses of 2 and 6 kg, respectively, and are in contact on a smooth horizontal surface. If a horizontal force of 6 N pushes them, calculate (a) the acceleration of the system and (b) the force that the 2-kg block exerts on the other block.

▮ (a) See Fig. 4-33(a). Considering the blocks to move as a unit, $M = m_a + m_b = 8 \text{ kg}$, $F = Ma = 6 \text{ N}$
 $a = \underline{0.75 \text{ m/s}^2}$.

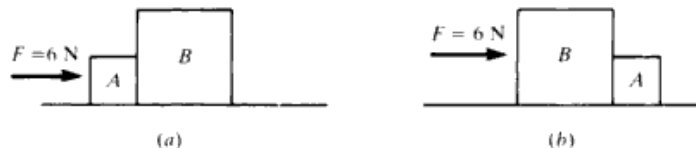

Fig. 4-33

(b) If we now consider block B to be our system, the only force acting on it is the force due to block A , F_{ab} . Then since the acceleration is the same as in part (a), we have $F_{ab} = M_b a = 4.5 \text{ N}$. However, we must consider also the case in which we reverse blocks A and B as in Fig. 4-33(b). As before, considering the blocks as a unit we have $a = 0.75 \text{ m/s}^2$. Now, however, if we consider block B as our system we have two forces acting, the force F to the right and the force F_{ab} to the left. Then $F - F_{ab} = M_b a$ and solving we get $F_{ab} = 1.5 \text{ N}$ in magnitude and points to the left.

We could verify these results by considering block A to be the system for the two cases.

- 4.93 In Fig. 4-34, the pulley is assumed massless and frictionless. Find the acceleration of the mass m in terms of F if there is no friction between the surface and m . Repeat if the frictional force on m is f .

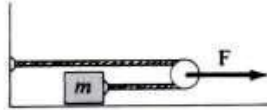

Fig. 4-34

▮ Note $T = F/2$. Newton's law for the block gives $T = ma$, hence $a = F/2m$. When friction is involved we have $F/2 - f = ma$, so $a = (F/2m) - (f/m)$.

- 4.94 In Fig. 4-35, assume that there is negligible friction between the blocks and table. Compute the tension in the cord and the acceleration of m_2 if $m_1 = 300 \text{ g}$, $m_2 = 200 \text{ g}$, and $F = 0.40 \text{ N}$.

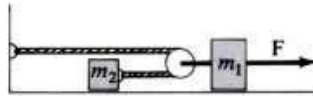

Fig. 4-35

▮ Write $F = ma$ for each block. Let a be the acceleration of m_2 . The acceleration of m_1 is then $a/2$ (compare Prob. 4.72). Then $T = m_2 a$ and $F - 2T = m_1(a/2)$. One finds $a = 0.73 \text{ m/s}^2$ and $T = 0.145 \text{ N}$.

- 4.95 How large must F be in Fig. 4-36 to give the 700-g block an acceleration of 30 cm/s^2 ? The coefficient of friction between the two blocks and also between block and table is 0.150.

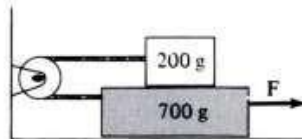

Fig. 4-36

▮ Converting to SI units, isolate each mass and note the forces that act on each. Vertically only the weights and normal forces are involved, $F_N = 0.2g$ on the upper block and $0.9g$ on the lower one. Friction forces are: $\mu(0.2g)$ between blocks and $\mu(0.9g)$ at the table. $F = ma$ for the blocks: $T - \mu(0.2g) = 0.2a$ and $F - T - \mu(0.2g) - \mu(0.9g) = 0.7a$; after eliminating tension T between these, $F = 0.9a + \mu(1.3g) = 0.9(0.30) + 0.150(1.3)(9.8) = 2.18 \text{ N}$.

- 4.96 Assume in Fig. 4-36 that the coefficient of friction is the same at the top and bottom of the 700-g block. If $a = 70 \text{ cm/s}^2$ when $F = 1.30 \text{ N}$, how large is the coefficient of friction?

▮ Following Prob. 4.95, $F = 0.9a + \mu(1.3g)$; then we use $F = 1.30 \text{ N}$ and $a = 0.700 \text{ m/s}^2$ to find $\mu = 0.053$.

- 4.97 In Fig. 4-37, when m is 3.0 kg, the acceleration of the block m is 0.6 m/s^2 , while $a = 1.6 \text{ m/s}^2$ if $m = 4.0 \text{ kg}$. Find the frictional force on block M as well as its mass. Neglect the mass and friction of the pulleys.

▮ Apply Newton's second law to m for each case: $3(9.8) - 2T_1 = 3(0.6)$, so $T_1 = 13.8 \text{ N}$; and $4(9.8) - 2T_2 = 4(1.6)$, so $T_2 = 16.4 \text{ N}$. Applying Newton's second law to M for each case, $13.8 - f = M(1.2)$ and $16.4 - f = M(3.2)$. Solve to find $M = 1.3 \text{ kg}$ and $f = 12.2 \text{ N}$.

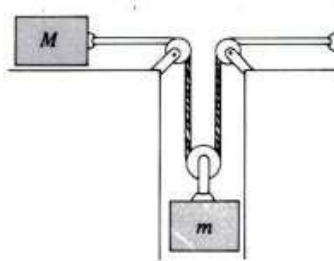

Fig. 4-37

- 4.98 In Fig. 4-38(a), block 1 is one-fourth the length of block 2 and weighs one-fourth as much. Assume that there is no friction between block 2 and the surface on which it moves and that the coefficient of sliding friction between blocks 1 and 2 is $\mu_k = 0.2$. After the system is released, find the distance block 2 has moved when only one-fourth of block 1 is still on block 2. Block 1 and block 3 have the same mass.

From Fig. 4-38(b), the equations of motion are

$$\sum F_1 = T - \mu_k w_1 = ma_1 \quad \sum F_2 = \mu_k w_1 = 4ma_2 \quad \sum F_3 = w_3 - T = ma_3$$

Solve the first and third equations simultaneously to get $a_1 = (g/2)(1 - \mu_k)$; from the second equation, $a_2 = (g/4)\mu_k$. Then the displacements of blocks 1 and 2 are given by $x = \frac{1}{2}at^2$, i.e.,

$$x_1 = \frac{g}{4}(1 - \mu_k)t^2 \quad x_2 = \frac{g}{8}\mu_k t^2$$

At the instant that one-fourth of block 1 remains on block 2, $x_2 + l = x_1 + (l/16)$, where l is the length of block 2. Therefore,

$$\frac{g}{8}\mu_k t^2 + l = \frac{g}{4}(1 - \mu_k)t^2 + \frac{l}{16} \quad \text{or} \quad t^2 = \frac{15l}{2g(2 - 3\mu_k)}$$

and

$$x_2 = \left(\frac{g}{8}\mu_k\right) \frac{15l}{2g(2 - 3\mu_k)} = \frac{15\mu_k}{16(2 - 3\mu_k)} l = \underline{7.47} l$$

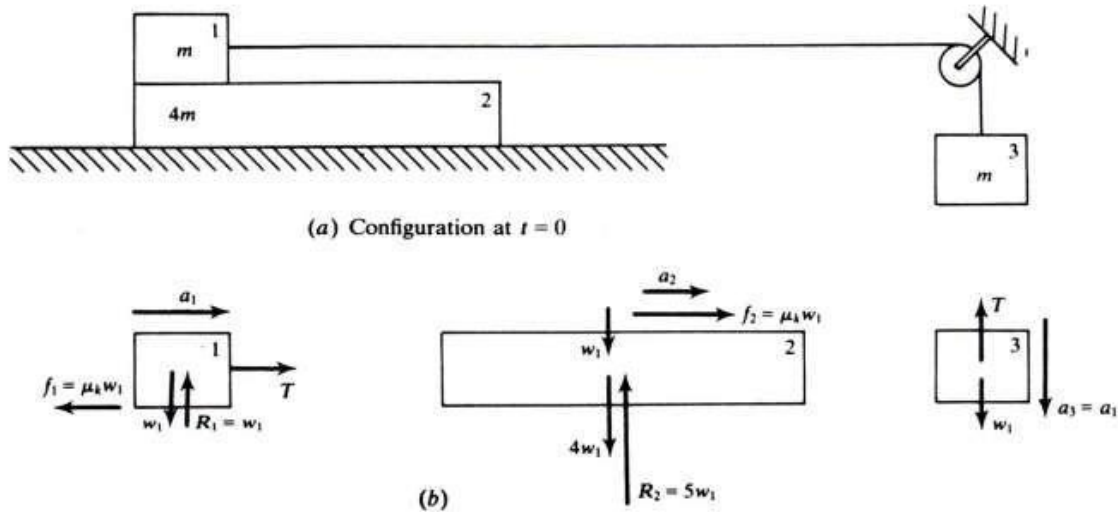

Fig. 4-38

- 4.99 A dinner plate rests on a tablecloth, with its center 0.3 m from the edge of the table. The tablecloth is suddenly yanked horizontally with a constant acceleration of 9.2 m/s^2 [Fig. 4-39(a)]. The coefficient of sliding friction between the tablecloth and the plate is $\mu_k = 0.75$. Find (a) the acceleration, (b) the velocity, and (c) the distance of the plate from the edge of the table, when the edge of the tablecloth passes under the center of the plate. Assume that the tablecloth just fits the tabletop.

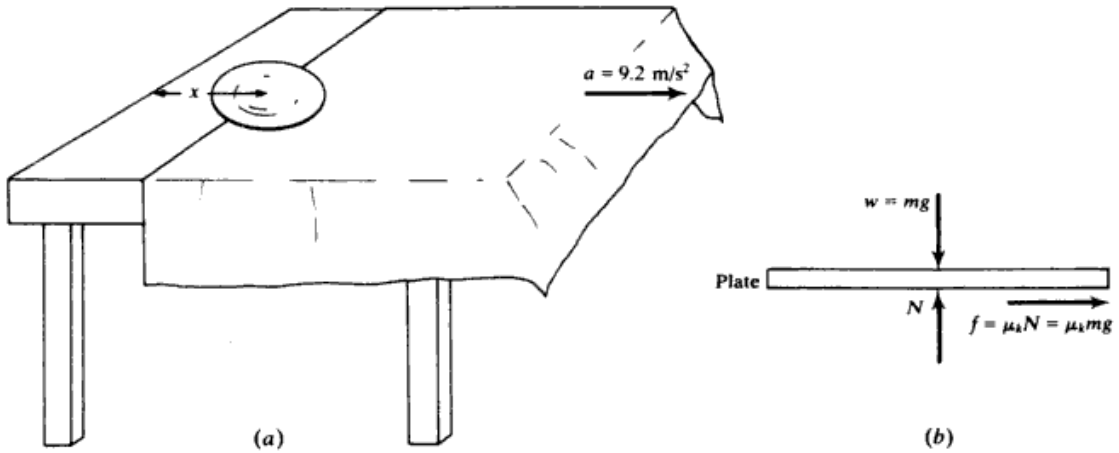

Fig. 4-39

▮ (a) from Fig. 4-39(b), the force equation for the plate is $\mu mg = ma_p$, or $a_p = \mu g = (0.75)(9.8) = 7.35 \text{ m/s}^2$. The plate slips, since a_p is less than 9.2 m/s^2 . (b) At the time the edge of the tablecloth is at the center of the plate, the cloth and the plate are at the same distance from the edge of the table:

$$x_p = x_c \quad 0.3 + \frac{1}{2}(7.4)t^2 = 0 + \frac{1}{2}(9.2)t^2$$

Solving, $t = 0.58 \text{ s}$ and $v_p = 0 + (7.35)(0.58) = 4.26 \text{ m/s}$.

(c)
$$x_p = 0.3 + 0(0.58) + \frac{1}{2}(7.35)(0.58)^2 = 1.54 \text{ m}$$

4.100 In the pulley system shown in Fig. 4-40, the movable pulleys A, B, C are of mass 1 kg each. D and E are fixed pulleys. The strings are vertical and inextensible. Find the tension in the string and the accelerations of the frictionless pulleys.

▮ Write y_A, y_B, y_C for the positions of the centers of the pulleys A, B, C at time t ; a_A, a_B, a_C are the accelerations at time t .

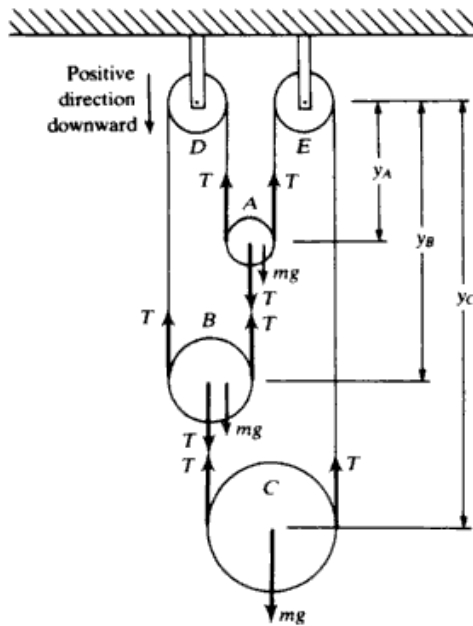

Fig. 4-40

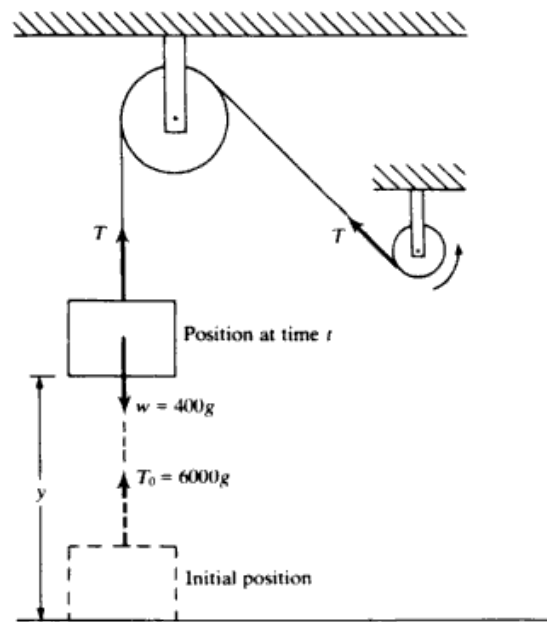

Fig. 4-41

Following the string from the end at the center of A to the end at the center of B , we get

$$(y_B - y_A) + y_B + 2y_A + y_C + (y_C - y_B) = \text{constant} \quad \text{or} \quad y_A + y_B + 2y_C = \text{constant}$$

Take the second time-derivative of this equation to get $a_A + a_B + 2a_C = 0$.

There is just one string and, thus, one tension T . The force equations are

$$T + mg - 2T = ma_A \quad T + mg - 2T = ma_B \quad mg - 2T = ma_C$$

Substituting $m = 1$ kg and solving the four equations for the four unknowns a_A , a_B , a_C , T , we obtain

$$a_A = a_B = -a_C = \frac{g}{3} = 3.3 \text{ m/s}^2 \quad T = 6.5 \text{ N}$$

- 4.101^c** A body of mass 400 kg is suspended at the lower end of a light vertical chain and is being pulled up vertically (see Fig. 4-41). Initially the body is at rest and the pull on the chain is 6000g N. The pull gets smaller uniformly at the rate of 360g N per each meter through which the body is raised. What is the velocity of the body when it has been raised 10 m?

| At time t , let y be the height (in meters) of the body above its initial position. The pull in the chain is then $T = (6000 - 360y)g$ and Newton's second law gives

$$T - 400g = 400\ddot{y} \quad \text{or} \quad (5600 - 360y)g = 400\ddot{y}$$

This equation may be changed into one for $\dot{y} = v$ (the velocity of the body) by use of the identity

$$2\ddot{y} = 2 \frac{dv}{dt} = 2 \frac{dv}{dy} \frac{dy}{dt} = 2v \frac{dv}{dy} = d(v^2)/dy$$

Thus
$$200 \frac{d(v^2)}{dy} = (5600 - 360y)g \quad \text{or} \quad d(v^2) = g(28 - 1.8y) dy$$

Let V be the velocity at height 10 m. Then, on integrating

$$\int_0^{V^2} d(v^2) = g \int_0^{10} (28 - 1.8y) dy \quad V^2 = g[28y - 0.9y^2]_0^{10} = g[28(10) - 0.9(100)] = 190g$$

$$V = +\sqrt{190g} = +43.2 \text{ m/s.}$$

The choice of the + sign for V (upward motion) should be checked. For $0 \leq y \leq 10$, the net force, $(5600 - 360y)g$, is positive, and so the acceleration is positive. Then, since the body started from rest, V must be positive.

CHAPTER 5

Motion in a Plane I

5.1 PROJECTILE MOTION

5.1 A marble with speed 20 cm/s rolls off the edge of a table 80 cm high. How long does it take to drop to the floor? How far, horizontally, from the table edge does the marble strike the floor?

| Choose downward as positive with origin at edge of table top.

$$v_{0x} = v_0 = 20 \text{ cm/s} \quad v_{0y} = 0 \quad a_y = +g = +980 \text{ cm/s}^2 \quad a_x = 0$$

To find time of fall, $y = v_{0y}t + \frac{1}{2}gt^2$, or $80 \text{ cm} = 0 + (490 \text{ cm/s}^2)t^2$; $t = 0.40 \text{ s}$. The horizontal distance is gotten from $x = v_{0x}t = (20 \text{ cm/s})(0.40 \text{ s}) = 8.0 \text{ cm}$.

5.2 How fast must a ball be rolled along a 70-cm-high table so that when it rolls off the edge it will strike the floor at this same distance (70 cm) from the point directly below the table edge?

| In the horizontal problem, $x = v_x t$ gives $v_x = 0.70/t$. In the vertical problem, choosing *down* as positive, $v_0 = 0$, $y = 0.7 \text{ m}$, and $a = 9.8 \text{ m/s}^2$. Use these values in $y = v_0 t + at^2/2$ to give $t = 0.378 \text{ s}$. Then $v_x = 1.85 \text{ m/s}$.

5.3 A marble traveling at 100 cm/s rolls off the edge of a level table. If it hits the floor 30 cm away from the spot directly below the edge of the table, how high is the table?

| This is a projectile problem with $v_{0x} = 100 \text{ cm/s}$. For the horizontal motion:

$$s_x = v_{0x}t \quad 30 = 100t \quad t = 0.30 \text{ s}$$

For the vertical motion:

$$s_y = v_{0y}t + \frac{1}{2}at^2 = 0 + \frac{1}{2}(980)(0.30)^2 = 44.1 \text{ cm} \quad (\text{height of the table})$$

5.4 In an ordinary television set, the electron beam consists of electrons shot horizontally at the television screen with a speed of about $5 \times 10^7 \text{ m/s}$. How far does a typical electron fall as it moves the approximately 40 cm from the electron gun to the screen? For comparison, how far would a droplet of water shot horizontally at 2 m/s from a hose drop as it moves a horizontal distance of 40 cm?

| For the electron, the horizontal problem yields the time to hit the screen as $t = x/v_x = 0.40/(5 \times 10^7) = 8 \times 10^{-9} \text{ s}$. Then in the vertical problem, $y = v_{0y}t + at^2/2$, so $y = 0 + 4.9(64 \times 10^{-18}) = 3.1 \times 10^{-16} \text{ m}$. For a droplet, $t = 0.40/2 = 0.20 \text{ s}$, and so $y = 0.196 \text{ m}$.

5.5 A body projected upward from the level ground at an angle of 50° with the horizontal has an initial speed of 40 m/s. How long will it be before it hits the ground?

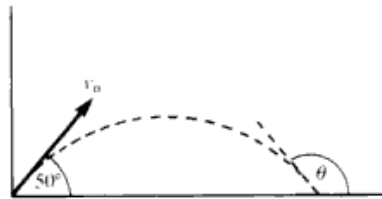

Fig. 5-1

| Choose *upward* as positive, and place the origin at the launch point (Fig. 5-1).

$$v_{0x} = v_0 \cos 50^\circ = (40 \text{ m/s})(0.642) = 25.7 \text{ m/s} \quad v_{0y} = v_0 \sin 50^\circ = (40 \text{ m/s})(0.766) = 30.6 \text{ m/s}$$

$$a_y = -g = -9.8 \text{ m/s}^2 \quad a_x = 0$$

To find the time in air, we have $y = v_{0y}t - \frac{1}{2}gt^2$ and since $y = 0$ at the end of flight, $0 = (30.6 \text{ m/s})t - (4.9 \text{ m/s}^2)t^2$, or $4.9t^2 = 30.6t$. The first solution $t = 0$ corresponds to the starting point, $y = 0$. The second solution is not zero and is obtained by dividing out by t . $4.9t = 30.6$ and $t = 6.24 \text{ s}$.

5.6 In Prob. 5.5, how far from the starting point will the body hit the ground, and at what angle with the horizontal?

▮ The horizontal distance traveled, or range R , is obtained from $R = v_{0x}t = (25.7 \text{ m/s})(6.24 \text{ s}) = \underline{160 \text{ m}}$. By symmetry it strikes at 50° (with negative x axis). This can also be seen by noting that $v_y = -v_{0y}$, $v_x = v_{0x}$, so $\tan \theta = -\tan \theta_0$ and therefore $180^\circ - \theta = \theta_0$.

- 5.7 A body is projected downward at an angle of 30° with the horizontal from the top of a building 170 m high. Its initial speed is 40 m/s. How long will it take before striking the ground?

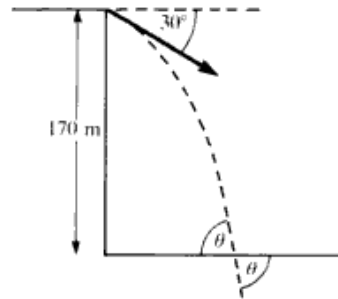

Fig. 5-2

▮ Choose *downward* as positive and origin at the top edge of building (Fig. 5-2).

$$v_{0x} = v_0 \cos 30^\circ = (40 \text{ m/s})(0.866) = 34.6 \text{ m/s} \quad v_{0y} = v_0 \sin 30^\circ = (40 \text{ m/s})(0.500) = 20.0 \text{ m/s}$$

$$a_y = g = 9.8 \text{ m/s}^2 \quad a_x = 0$$

We can solve for the time in different ways. Method 1:

$$y = v_{0y}t + \frac{1}{2}gt^2 \quad \text{or} \quad 170 \text{ m} = (20.0 \text{ m/s})t + (4.9 \text{ m/s}^2)t^2$$

We can solve the quadratic to yield

$$t = \frac{-20 \pm (400 + 3332)^{1/2}}{9.8} = \underline{4.2 \text{ s}}$$

(We keep only the positive solution; the negative time corresponds to a time before $t = 0$ when it would have been at ground level if it were a projectile launched so as to reach the starting position and velocity at $t = 0$.)

Method 2: We avoid the quadratic. First find v_y just before impact:

$$v_y^2 = v_{0y}^2 + 2gy \quad \text{or} \quad v_y^2 = (20.0 \text{ m/s})^2 + 2(9.8 \text{ m/s}^2)(170 \text{ m}) \quad v_y = \pm 61 \text{ m/s}$$

For our case $v_y = 61 \text{ m/s}$. Next we find t :

$$v_y = v_{0y} + gt \quad \text{or} \quad 61 \text{ m/s} = 20.0 \text{ m/s} + (9.8 \text{ m/s}^2)t \quad \text{or} \quad t = \underline{4.2 \text{ s}}$$

- 5.8 In Prob. 5.7, find out how far from the foot of the building the body will strike and at what angle with the horizontal.

▮ $x = v_{0x}t = (34.6 \text{ m/s})(4.2 \text{ s}) = \underline{145 \text{ m}}$. We need the angle that the vector velocity makes with the x axis just before hitting the ground. We avoid having to directly deduce the quadrant this angle is in by solving for the acute angle θ made with the x axis (positive or negative; above or below).

$$\tan \theta = \left| \frac{v_y}{v_x} \right| = 1.76 \quad \text{and} \quad \theta = \underline{60.4^\circ}$$

Since v_y is negative and v_x is positive, this is clearly the angle below the positive x axis (see Fig. 5-2) and equals the angle we are looking for.

- 5.9 A body is projected from the ground at an angle of 30° with the horizontal at an initial speed of 128 ft/s. Ignoring air friction, determine (a) in how many seconds it will strike the ground, (b) how high it will go, and (c) what its range will be.

▮ (a) Find v_{0y} and then determine the time for a freely falling body projected upward at this velocity to return to the ground; that is, $s_y = 0$. From Fig. 5-3,

$$v_{0y} = v \sin \theta = 128 \sin 30^\circ = 64 \text{ ft/s} \quad s_y = v_{0y}t + \frac{1}{2}gt^2 \quad 0 = 64t + \frac{1}{2}(-32)t^2 = (64 - 16t)t \quad t = \underline{4 \text{ s}}$$

(b) Since time of ascent is equal to time of descent, the projectile reaches maximum height H at $t = 2 \text{ s}$. Thus,

$$H = v_{0y}t + \frac{1}{2}gt^2 = 64(2) + \frac{1}{2}(-32)(2)^2 = \underline{64 \text{ ft}}$$

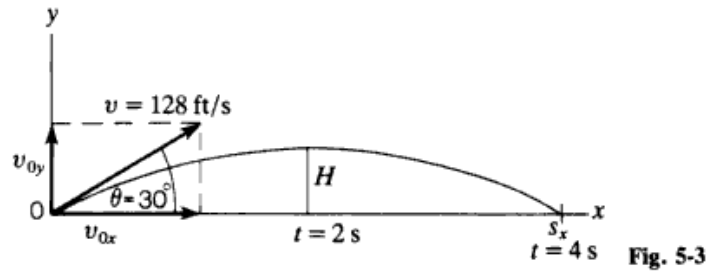

(c) The projectile travels with a constant velocity $v_x = v \cos \theta$ in the x direction. It reaches the ground in 4 s. The range is

$$s_x = v_x t = (v \cos \theta)t = 128(\cos 30^\circ)4 = 512(0.866) = 443 \text{ ft}$$

- 5.10 A hose lying on the ground shoots a stream of water upward at an angle of 40° to the horizontal. The speed of the water is 20 m/s as it leaves the hose. How high up will it strike a wall which is 8 m away?

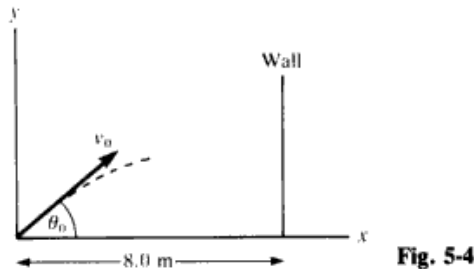

Setting coordinates as shown in Fig. 5-4, with $v_0 = 20 \text{ m/s}$ and $\theta_0 = 40^\circ$, we get

$$v_{0x} = v_0 \cos \theta_0 = (20 \text{ m/s}) \cos 40^\circ = 15.3 \text{ m/s} \quad v_{0y} = v_0 \sin \theta_0 = (20 \text{ m/s}) \sin 40^\circ = 12.8 \text{ m/s}$$

$x = v_{0x}t$, and setting $x = 8 \text{ m}$ we find the time to hit the wall: $8 \text{ m} = (15.3 \text{ m/s})t$, yielding $t = 0.52 \text{ s}$. To find the height at which it hits the wall, we use $y = v_{0y}t - \frac{1}{2}gt^2$, with $t = 0.52 \text{ s}$. This yields $y = (12.8 \text{ m/s})(0.52 \text{ s}) - (4.9 \text{ m/s}^2)(0.52 \text{ s})^2 = 5.33 \text{ m}$.

- 5.11 A baseball batter hits a home run ball with a velocity of 132 ft/s at an angle of 26° above the horizontal. A fielder who has a reach of 7 ft above the ground is backed up against the bleacher wall, which is 386 ft from home plate. The ball was 3 ft above the ground when hit. How high above the fielder's glove does the ball pass?

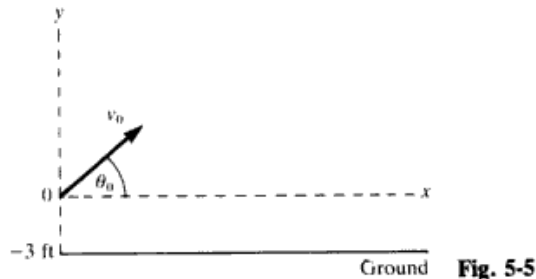

The situation is depicted in Fig. 5-5, with the origin and x axis 3 ft above the ground. We must find the value of y on the ball's trajectory corresponding to $x = 386 \text{ ft}$. Then we can subtract the height of the fielder's glove above the x axis, i.e., $7 \text{ ft} - 3 \text{ ft} = 4 \text{ ft}$. To find y we note that

$$v_{0x} = v_0 \cos \theta_0 = (132 \text{ ft/s}) \cos 26^\circ = 119 \text{ ft/s} \quad v_{0y} = v_0 \sin \theta_0 = (132 \text{ ft/s}) \sin 26^\circ = 57.9 \text{ ft/s}$$

The time to reach $x = 386 \text{ ft}$ is given by $x = v_{0x}t$, or $386 \text{ ft} = (119 \text{ ft/s})t$, and $t = 3.24 \text{ s}$.

Then $y = v_{0y}t - \frac{1}{2}gt^2 = (57.9 \text{ ft/s})(3.24 \text{ s}) - \frac{1}{2}(32 \text{ ft/s}^2)(3.24 \text{ s})^2 = 19.6 \text{ ft}$. Height above glove = $19.6 \text{ ft} - 4 \text{ ft} = 15.6 \text{ ft}$. [Note: The trajectory equation $y = (\tan \theta_0)x - gx^2/(2v_0^2 \cos^2 \theta_0)$ can also be used to find y .]

- 5.12 A ball is thrown upward at an angle of 30° to the horizontal and lands on the top edge of a building that is 20 m away. The top edge is 5 m above the throwing point. How fast was the ball thrown?

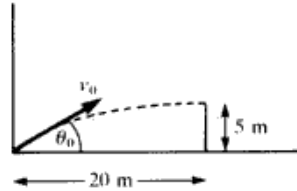

Fig. 5-6

▮ The situation is depicted in Fig. 5-6 with $\theta_0 = 30^\circ$. We can use the trajectory equation $y = \tan \theta_0 x - gx^2/(2v_0^2 \cos^2 \theta_0)$, setting $x = 20 \text{ m}$ and $y = 5 \text{ m}$. Then $5 \text{ m} = (0.58)(20 \text{ m}) - (9.8 \text{ m/s}^2)(20 \text{ m})^2/(2v_0^2 \times 0.75)$, or $v_0 = 20 \text{ m/s}$. (Note: If you didn't remember the trajectory equation, you could still solve the problem by using the x -vs.- t and y -vs.- t equations.)

- 5.13 A projectile is fired with initial velocity $v_0 = 95 \text{ m/s}$ at an angle $\theta = 50^\circ$. After 5 s it strikes the top of a hill. What is the elevation of the hill above the point of firing? At what horizontal distance from the gun does the projectile land?

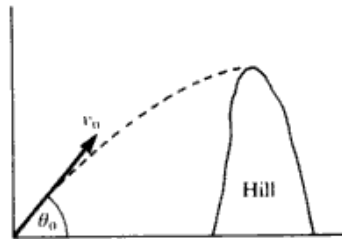

Fig. 5-7

▮ The situation is as shown in Fig. 5-7. $v_0 = 95 \text{ m/s}$; $\theta_0 = 50^\circ$. At any time t , $y = v_{0y}t - \frac{1}{2}gt^2$, where $v_{0y} = v_0 \sin \theta_0 = 72.8 \text{ m/s}$. For $t = 5 \text{ s}$, we get $y = (72.8 \text{ m/s})(5.0 \text{ s}) - \frac{1}{2}(9.8 \text{ m/s}^2)(5.0 \text{ s})^2 = 241 \text{ m}$. The horizontal distance, x , is given by $x = v_{0x}t = v_0 \cos \theta_0 t = (61.1 \text{ m/s})t$. At $t = 5 \text{ s}$, we have $x = 305 \text{ m}$.

- 5.14 A ball is thrown with a speed of 20 m/s at an angle of 37° above the horizontal. It lands on the roof of a building at a point displaced 24 m horizontally from the throwing point. How high above the throwing point is the roof?

▮ The velocity components are $v_{0x} = 16 \text{ m/s}$ and $v_{0y} = 12 \text{ m/s}$. In the horizontal problem, $t = x/v_x = 24/16 = 1.5 \text{ s}$. Then in the vertical problem we have $y = v_{0y}t + at^2/2$, so $y = 12(1.5) - 4.9(2.25) = 7.0 \text{ m}$.

- 5.15 A hit baseball leaves the bat with a velocity of 110 ft/s at 45° above the horizontal. The ball hits the top of a screen at the 320-ft mark and bounces into the crowd for a home run. How high above the ground is the top of the screen? (Neglect air resistance.)

▮ $s_x = v_x t$ $v_x = 110 \cos 45^\circ = \text{a constant}$ $320 = 110(0.707)t$ $t = 4.11 \text{ s}$
 $s_y = v_{0y}t + \frac{1}{2}at^2 = (110 \sin 45^\circ)(4.11) + \frac{1}{2}(-32)(4.11)^2 = (110)(0.707)(4.11) + \frac{1}{2}(-32)(4.11)^2$
 $= 319.6 - 270.3$ $s_y = 49 \text{ ft}$ (height of screen)

- 5.16 A ball is thrown upward from a point on the side of a hill which slopes upward uniformly at an angle of 28° . Initial velocity of ball: $v_0 = 33 \text{ m/s}$, at an angle $\theta_0 = 65^\circ$ (with respect to the horizontal). At what distance up the slope does the ball strike and in what time?

▮ The situation is depicted in Fig. 5-8. $v_0 = 33 \text{ m/s}$ and $\theta_0 = 65^\circ$. The trajectory equation of the ball is

$$y_b = (\tan \theta_0)x - gx^2/2v_0^2 \cos^2 \theta_0 = 2.14x - 0.025x^2$$

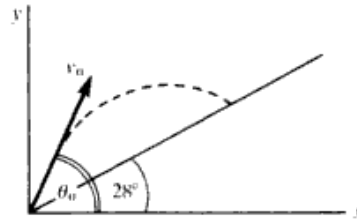

Fig. 5-8

The equation for the incline is $y = (\tan 28^\circ)x = 0.53x$. At the value of x for which the ball hits the incline $y_h = y_i$, or $0.53x = 2.14x - 0.025x^2$, and $0.025x^2 = 1.61x$, which yields $x = 64.4$ m. The distance along the incline, S , obeys $x = S \cos 28^\circ$ or $S = 72.9$ m. The time to reach any x value is given by $x = v_{0x}t = (v_0 \cos \theta_0)t = 13.9t$. So for $x = 64.4$ m, $t = 4.63$ s.

- 5.17 A projectile is to be shot at 50 m/s over level ground in such a way that it will land 200 m from the shooting point. At what angle should the projectile be shot?

| In the horizontal problem, $x = v_{0x}t$ gives $200 = (50 \cos \theta)t$, where θ is the angle we seek. In the vertical problem, $y = v_{0y}t + at^2/2$ gives $0 = 50 \sin \theta - 4.9t$. But $t = 200/(50 \cos \theta)$, and so $50 \sin \theta = 4.9(200/\cos \theta)$. This simplifies to $2 \sin \theta \cos \theta = 0.784$, and so $\sin 2\theta = 0.784$, from which $\theta = 25.8^\circ$.

- 5.18 As shown in Fig. 5-9, a ball is thrown from the top of one building toward a tall building 50 ft away. The initial velocity of the ball is 20 ft/s at 40° above the horizontal. How far above or below its original level will the ball strike the opposite wall?

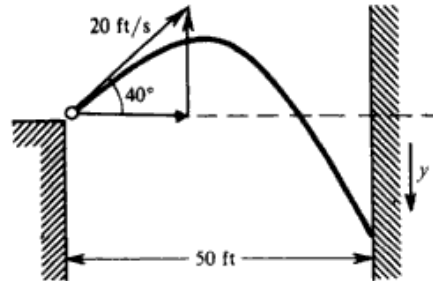

Fig. 5-9

| $v_{0x} = (20 \text{ ft/s}) \cos 40^\circ = 15.3 \text{ ft/s}$ $v_{0y} = (20 \text{ ft/s}) \sin 40^\circ = 12.9 \text{ ft/s}$

In the horizontal motion, $v_{0x} = v_x = \bar{v}_x = 15.3 \text{ ft/s}$. Then $x = \bar{v}_x t$ gives $50 \text{ ft} = (15.3 \text{ ft/s})t$, or $t = 3.27$ s. In the vertical motion, taking *down* as positive,

$$y = v_{0y}t + \frac{1}{2}at^2 = (-12.9 \text{ ft/s})(3.27 \text{ s}) + \frac{1}{2}(32.2 \text{ ft/s}^2)(3.27 \text{ s})^2 = 130 \text{ ft below}$$

- 5.19 (a) Find the range x of a gun which fires a shell with muzzle velocity v at an angle of elevation θ . (b) Find the angle of elevation θ of a gun which fires a shell with a muzzle velocity of 1.2 km/s at a target on the same level but 15 km distant. See Fig. 5-10.

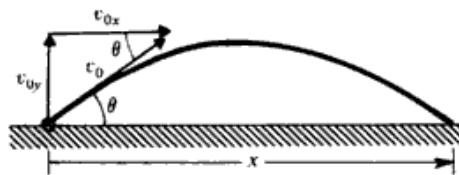

Fig. 5-10

| (a) Let t be the time it takes the shell to hit the target. Then, $x = v_{0x}t$ or $t = x/v_{0x}$. Consider the vertical motion alone, and take *up* as positive. When the shell strikes the target, vertical displacement = 0 = $v_{0y}t + \frac{1}{2}(-g)t^2$. Solving this equation gives $t = 2v_{0y}/g$. But $t = x/v_{0x}$, so

$$\frac{x}{v_{0x}} = \frac{2v_{0y}}{g} \quad \text{or} \quad x = \frac{2v_{0x}v_{0y}}{g} = \frac{2(v_0 \cos \theta)(v_0 \sin \theta)}{g} = \frac{v_0^2 \sin 2\theta}{g}$$

(b) From the range equation found in (a),

$$\sin 2\theta = \frac{gx}{v_0^2} = \frac{(9.8 \times 10^{-3} \text{ km/s}^2)(15 \text{ km})}{(1.2 \text{ km/s})^2} = 0.102$$

whence $2\theta = 5.9^\circ$ and $\theta = 3.0^\circ$.

5.20 A rifle bullet has a muzzle velocity of 680 ft/s. (a) At what angle (ignoring air resistance) should the rifle be pointed to give the maximum range? (b) Evaluate the maximum range.

▮ (a) By Prob. 5.19(a), the range is a maximum when $\sin 2\theta = 1$, or $\theta = 45^\circ$.

(b) $x_{\max} = \frac{v_0^2}{g} = \frac{(680 \text{ ft/s})^2}{32 \text{ ft/s}^2} = 14\,450 \text{ ft}.$

5.21 A golf ball leaves the golf club at an angle of 60° above the horizontal with a velocity of 30 m/s. (a) How high does it go? (b) Assuming a level fairway, determine how far away it hits the ground.

▮ (a) With *up* positive, $v_{0y} = 30 \sin 60^\circ = 15\sqrt{3} \text{ m/s}$ and, at maximum height, v_y equals zero. Thus,

$$v_y^2 = v_{0y}^2 + 2ah \quad 0 = 675 - 19.6h \quad h = \frac{675}{19.6} = \underline{34.4 \text{ m}}$$

(b) By Prob. 5.19(a),

$$x = \frac{v_0^2 \sin 2\theta}{g} = \frac{900(\sqrt{3}/2)}{9.8} = \underline{79.5 \text{ m}}$$

5.22 Prove that a gun will shoot three times as high when its angle of elevation is 60° as when it is 30° , but will carry the same horizontal distance.

▮ We assume that v_0 is the same at both angles. Maximum height is given by the condition $v_y = 0$. Then, $v_y^2 = v_{0y}^2 - 2gy$ yields $y_{\max} = v_{0y}^2/(2g)$. Noting that $v_{0y} = v_0 \sin \theta_0$, we have finally $y_{\max} = (v_0^2 \sin^2 \theta)/2g$. Then $y_{\max}(60^\circ)/y_{\max}(30^\circ) = \sin^2 60^\circ/\sin^2 30^\circ = 3$. To show that the horizontal range is the same, we note that in the range formula [Prob. 5.19(a)] $\cos 60^\circ \sin 60^\circ = \cos 30^\circ \sin 30^\circ$ since 30° and 60° are complementary angles.

5.23 As shown in Fig. 5-11, a projectile is fired with a horizontal velocity of 330 m/s from the top of a cliff 80 m high. (a) How long will it take for the projectile to strike the level ground at the base of the cliff? (b) How far from the foot of the cliff will it strike? (c) With what velocity will it strike?

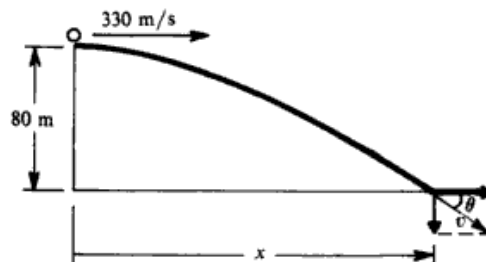

Fig. 5-11

▮ (a) The horizontal and vertical motions are independent of each other. Consider first the vertical motion. Taking *down* as positive we have $y = v_{0y}t + \frac{1}{2}a_y t^2$, or $80 \text{ m} = 0 + \frac{1}{2}(9.8 \text{ m/s}^2)t^2$, from which $t = \underline{4.04 \text{ s}}$. Note that the initial velocity had zero vertical component, and so $v_{0y} = 0$ in the vertical motion.

(b) Now consider the horizontal motion. For it, $a = 0$ and so $\bar{v}_x = v_{0x} = v_x = 330 \text{ m/s}$. Then, using the value of t found in (a), $x = \bar{v}_x t = (330 \text{ m/s})(4.04 \text{ s}) = \underline{1330 \text{ m}}$.

(c) The final velocity has a horizontal component of 330 m/s. But its vertical velocity at $t = 4.04 \text{ s}$ is given by $v_{fy} = v_{0y} + a_y t$ as $v_{fy} = 0 + (9.8 \text{ m/s}^2)(4.04 \text{ s}) = 40 \text{ m/s}$. The resultant of these two components is labeled v in Fig. 5-11; we have

$$v = \sqrt{(40 \text{ m/s})^2 + (330 \text{ m/s})^2} = \underline{332 \text{ m/s}}$$

Angle θ shown is given by $\tan \theta = 40/330$ to be $\underline{6.9^\circ}$.

- 5.24 A stunt flier is moving at 15 m/s parallel to the flat ground 100 m below. How large must the horizontal distance x from plane to target be if a sack of flour released from the plane is to strike the target?

▮ Following the same procedure as in Prob. 5.23, use $y = v_{0y}t + \frac{1}{2}a_y t^2$ to get $100 \text{ m} = 0 + \frac{1}{2}(9.8 \text{ m/s}^2)t^2$, or $t = 4.5 \text{ s}$. Now use $x = v_x t = (15 \text{ m/s})(4.5 \text{ s}) = \underline{68 \text{ m}}$, since the sack's initial velocity is that of the plane.

- 5.25 A baseball is thrown with an initial velocity of 100 m/s at an angle of 30° above the horizontal. How far from the throwing point will the baseball attain its original level?

▮ By the range formula,

$$x = \frac{v_0^2 \sin 2\theta}{g} = \frac{10^4(\sqrt{3}/2)}{9.8} = \underline{890 \text{ m}}$$

- 5.26 A cart is moving horizontally along a straight line with constant speed 30 m/s. A projectile is to be fired from the moving cart in such a way that it will return to the cart after the cart has moved 80 m. At what speed (relative to the cart) and at what angle (to the horizontal) must the projectile be fired?

▮ To move horizontally with the cart, the projectile must be fired vertically with a flight time $= x/v_x = (80 \text{ m})/(30 \text{ m/s}) = 2.67 \text{ s}$. The initial velocity v_0 must satisfy $y = v_0 t + at^2/2$, with $y = 0$ and $t = 2.67 \text{ s}$; thus $4.9t = v_0$, and so $v_0 = \underline{13.1 \text{ m/s}}$ at $\theta = 90^\circ$.

- 5.27 In Fig. 5-12, α particles from a bit of radioactive material enter through slit S into the space between two large parallel metal plates, A and B , connected to a source of voltage. As a result of the uniform electric field between the plates, each particle has a constant acceleration $a = 4 \times 10^{13} \text{ m/s}^2$ normal to and toward B . If $v_0 = 6 \times 10^6 \text{ m/s}$ and $\theta = 45^\circ$, determine h and R .

▮ Here the electric force takes the place of gravity, but otherwise the analysis is the same. Choosing *upward* as positive, i.e., the direction from B to A , we have a regular trajectory problem with $v_0 = 6 \times 10^6 \text{ m/s}$; $\theta_0 = 45^\circ$; $a_y = -4 \times 10^{13} \text{ m/s}^2$; $a_x = 0$. Then $x = v_{0x}t = v_0 \cos \theta_0 t = (4.24 \times 10^6 \text{ m/s})t$; and similarly

$$y = v_{0y}t + \frac{1}{2}a_y t^2 = (4.24 \times 10^6 \text{ m/s})t - (2.0 \times 10^{13} \text{ m/s}^2)t^2$$

$$v_y = v_{0y} + a_y t = (4.24 \times 10^6 \text{ m/s}) - (4.0 \times 10^{13} \text{ m/s}^2)t$$

At the highest point, $y = h$, $v_y = 0$, and $t = 1.06 \times 10^{-7} \text{ s}$. Thus $h = (4.24 \times 10^6)(1.06 \times 10^{-7}) - (2.0 \times 10^{13})(1.06 \times 10^{-7})^2 = 0.225 \text{ m}$. The horizontal range R corresponds to x at the time the α particle returns to plate B . By symmetry, this is $2t = 2.12 \times 10^{-7} \text{ s}$. Then $R = (4.24 \times 10^6 \text{ m/s})(2.12 \times 10^{-7} \text{ s}) = \underline{0.90 \text{ m}}$.

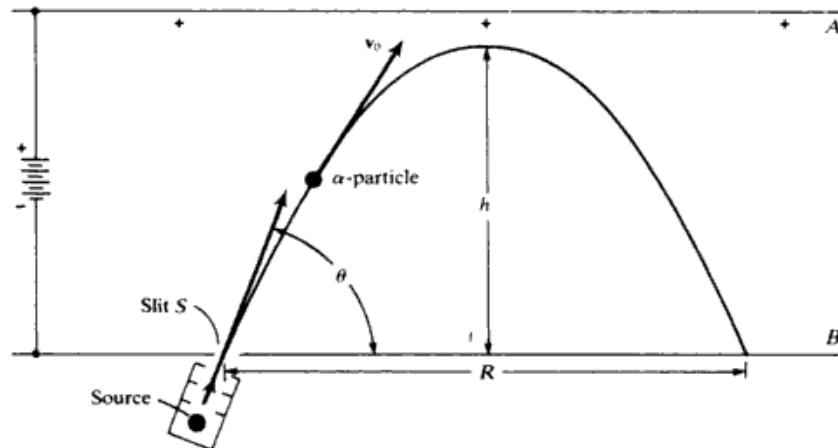

Fig. 5-12

- 5.28 A ball is thrown upward from the top of a 35-m tower, Fig. 5-13, with initial velocity $v_0 = 80 \text{ m/s}$ at an angle $\theta = 25^\circ$. (a) Find the time to reach the ground and the distance R from P to the point of impact. (b) Find the magnitude and direction of the velocity at the moment of impact.

▮ (a) At the point of impact, $y = -35 \text{ m}$ and $x = R$. From $y = -35 = (80 \sin 25^\circ)t - \frac{1}{2}(9.8)t^2$, $t = \underline{7.814 \text{ s}}$. Then $x = R = (80 \cos 25^\circ)(7.814) = \underline{566.55 \text{ m}}$.

(b) At impact, $v_y = 80 \sin 25^\circ - (9.8)(7.814) = -42.77 \text{ m/s}$ and $v_x = v_{0x} = 80 \cos 25^\circ = 72.5 \text{ m/s}$. Thus $v = (42.77^2 + 72.5^2)^{1/2} = 84.18 \text{ m/s}$ and $\tan \beta = -42.77/72.5$, or $\beta = -30.54^\circ$.

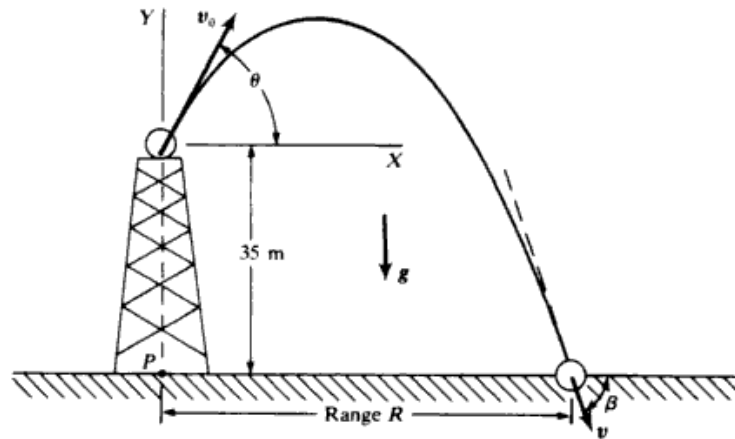

Fig. 5-13

5.29 The arrangement in Fig. 5-14 is the same as that in Fig. 5-12 except that α particles enter slit S from two sources, A_1 and A_2 , at angles θ_1 and θ_2 , respectively. v_0 and a are the same for both groups. Given that $v_0 = 6 \times 10^6$ m/s, $a = 4 \times 10^{13}$ m/s², $\theta_1 = 45^\circ + 1^\circ$, $\theta_2 = 45^\circ - 1^\circ$, show that all particles are “focused” at a single point P and find the value of R .

| Here we can use the horizontal range formula $R = 2v_0^2 \cos \theta_0 \sin \theta_0 / a$. Noting that for the first α particle $\theta_0 = \theta_1 = 46^\circ$ and for the second α particle $\theta_0 = \theta_2 = 44^\circ$, we see that the two are complementary angles. Then $\cos \theta_1 \sin \theta_1 = \sin \theta_2 \cos \theta_2$ and the ranges are the same. Indeed $R = 2(6 \times 10^6 \text{ m/s})^2(0.719)(0.695) / (4 \times 10^{13} \text{ m/s}^2) = 0.90 \text{ m}$.

5.30 Again referring to Fig. 5-14, find $h_1 - h_2$.

| For the vertical heights we have $v_y^2 = v_{0y}^2 + 2a_y y$ with $v_y = 0$; $a_y = -|a| = 4 \times 10^{13}$ m/s². Then

$$h_1 = \frac{(v_0 \sin \theta_1)^2}{2|a|} = 0.233 \text{ m} \quad h_2 = \frac{(v_0 \sin \theta_2)^2}{2|a|} = 0.217 \text{ m} \quad h_1 - h_2 = 0.016 \text{ m} = 16 \text{ mm}$$

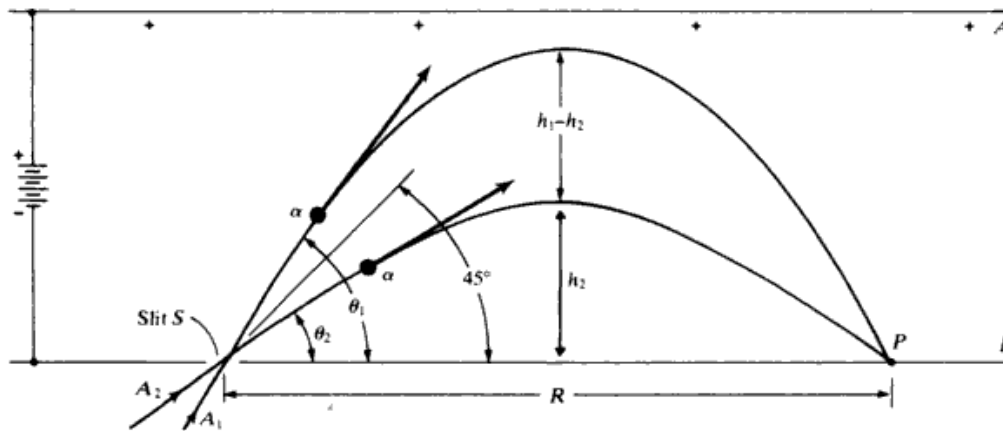

Fig. 5-14

5.31 A ball is thrown upward with initial velocity $v_0 = 15.0$ m/s at an angle of 30° with the horizontal. The thrower stands near the top of a long hill which slopes downward at an angle of 20° . When does the ball strike the slope?

| We choose the launch point at the origin (see Fig. 5-15). The equations of motion of the ball are

$$x = v_0 \cos 30^\circ t = (13.0 \text{ m/s})t \quad y = v_0 \sin 30^\circ t - \frac{1}{2}gt^2 = (7.5 \text{ m/s})t - (4.9 \text{ m/s}^2)t^2$$

The equation of the straight line incline is $y = -x \tan 20^\circ = -0.364x$. We want the time at which the (x, y) values for the ball satisfy this equation. We thus substitute the time expressions for y and x :

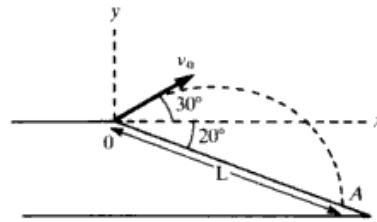

Fig. 5-15

$(7.5 \text{ m/s})t - (4.9 \text{ m/s}^2)t^2 = -0.364[(13.0 \text{ m/s})t]$, or $12.2t = 4.9t^2$. The solutions are $t = 0$ (corresponding to $x = y = 0$) and $t = 2.49 \text{ s}$.

5.32 Referring to Prob. 5.31 determine how far down the slope the ball strikes.

▮ Referring to Fig. 5-15 we need the x and y components of the displacement to position A : $x = (13.0 \text{ m/s})(2.49 \text{ s}) = 32.4 \text{ m}$; $y = -0.364x = -11.8 \text{ m}$. Then $L = \sqrt{x^2 + y^2} = 34.5 \text{ m}$ (or directly from x , $L = x/\cos 20^\circ = 34.5 \text{ m}$).

5.33 Referring to Prob. 5.31 indicate with what velocity the ball hits.

▮ For the velocity of the ball just before impact, \mathbf{v}_A :

$$v_{Ax} = v_0 \cos 30^\circ = 13.0 \text{ m/s} \quad v_{Ay} = v_0 \sin 30^\circ - gt = 7.5 \text{ m/s} - (9.8 \text{ m/s}^2)(2.49 \text{ s}) = -16.9 \text{ m/s}$$

Thus

$$v_A = \sqrt{v_{Ax}^2 + v_{Ay}^2} = 21.3 \text{ m/s} \quad \theta_A = \tan^{-1} \left| \frac{v_{Ay}}{v_{Ax}} \right| = 52.4^\circ \quad \text{below positive } x \text{ axis}$$

5.34 A bomber, Fig. 5-16, is flying level at a speed $v_1 = 72 \text{ m/s}$ (about 161 mi/h), at an elevation of $h = 103 \text{ m}$. When directly over the origin bomb B is released and strikes the truck T , which is moving along a level road (the X axis) with constant speed. At the instant the bomb is released the truck is at a distance $x_0 = 125 \text{ m}$ from O . Find the value of v_2 and the time of flight of B . (Assume that the truck is 3 m high.)

▮ The equations for x and y motion of the bomb are

$$x = v_{0x}t = v_1t = (72 \text{ m/s})t \quad y = y_0 + v_{0y}t - \frac{1}{2}gt^2 = h - \frac{1}{2}gt^2 = 103 \text{ m} - (4.9 \text{ m/s}^2)t^2$$

The time for hitting the truck corresponds to $y = 3 \text{ m}$, so

$$3 \text{ m} = 103 \text{ m} - (4.9 \text{ m/s}^2)t^2 \quad \frac{100}{4.9} = t^2 \quad t = 4.52 \text{ s}$$

Then $x = (72 \text{ m/s})(4.52 \text{ s}) = 325 \text{ m}$.

$$v_2 = \frac{x - x_0}{t} = \frac{325 \text{ m} - 125 \text{ m}}{4.52 \text{ s}} = 44.2 \text{ m/s}$$

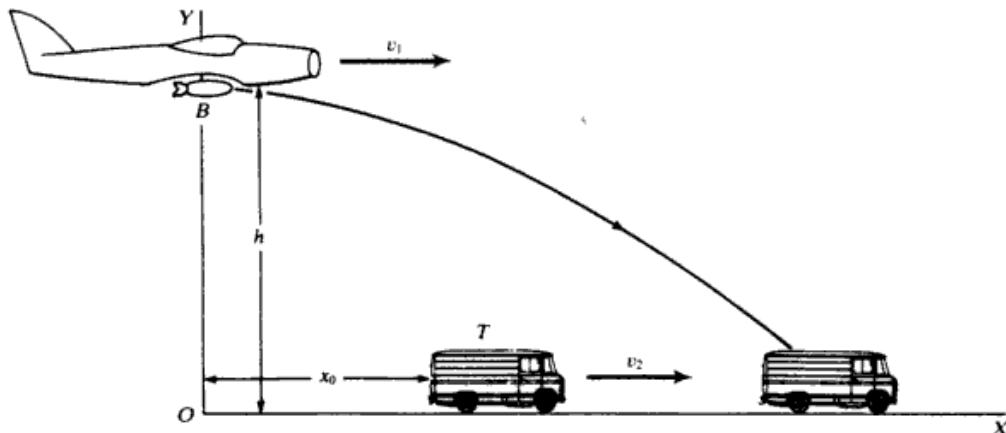

Fig. 5-16

5.35 A projectile, Fig. 5-17, is fired upward with velocity v_0 at an angle θ . (a) At what point $P(x, y)$ does it strike the roof of the building, and in what time? (b) Find the magnitude and direction of \mathbf{v} at P . Let $\theta = 35^\circ$, $v_0 = 40$ m/s, $\alpha = 30^\circ$, and $h = 15$ m.

▮ First note that (using notation $\dot{x} = v_x$, $\dot{y} = v_y$)

$$\dot{x}_0 = v_0 \cos 35^\circ = 32.7661 \text{ m/s} \quad \dot{y}_0 = v_0 \sin 35^\circ = 22.943 \text{ m/s}$$

and, from the equation of the roof,

$$y = h - x \tan \alpha = 15 - (0.57735)x \tag{1}$$

(a) Eliminating t from $y = \dot{y}_0 t - 4.9t^2$ by $x = \dot{x}_0 t$, we have

$$y = \left(\frac{\dot{y}_0}{\dot{x}_0}\right)x - \frac{4.9x^2}{\dot{x}_0^2} \tag{2}$$

for the path of the projectile. Equating y in (1) to y in (2) and inserting numerical values, $0.004564x^2 - 1.277558x + 15 = 0$, from which $x = 12.28$ m. Then $y = h - (12.28) \tan \alpha = 7.90$ m. The time to strike is given by $12.28 = 32.7661t$, or $t = 0.375$ s.

(b) At P , $\dot{x} = \dot{x}_0 = 32.766 \text{ m/s}$ $\dot{y} = \dot{y}_0 - 9.8t = 22.943 - (9.8)(0.375) = 19.268 \text{ m/s}$

Thus $v = (\dot{x}^2 + \dot{y}^2)^{1/2} = 38.0 \text{ m/s}$ and $\tan \beta = \dot{y}/\dot{x} = 0.588$, or $\beta = 30.46^\circ$, where β is the angle that \mathbf{v} makes with X at P .

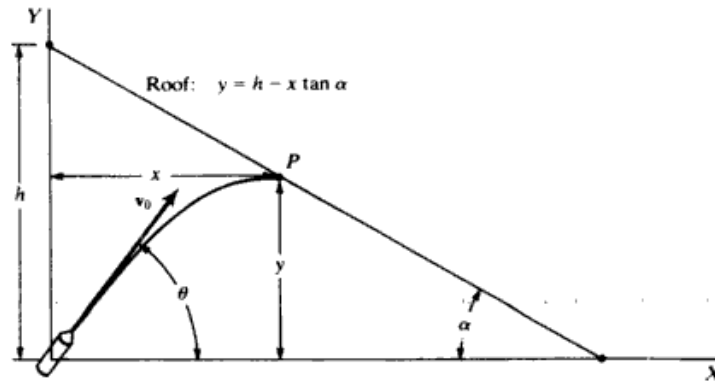

Fig. 5-17

5.36 In Prob. 5.35, angle θ can be adjusted. Find the value of θ for which the projectile strikes the roof in a minimum time.

▮ Again $y = \dot{y}_0 t - \frac{1}{2}gt^2 = (v_0 \sin \theta)t - \frac{1}{2}gt^2$ and $y = h - x \tan \alpha$

Equating these two expressions for y and eliminating x by $x = \dot{x}_0 t = (v_0 \cos \theta)t$, we obtain the following equation for the time of striking: $\frac{1}{2}gt^2 - v_0(\cos \theta \tan \alpha + \sin \theta)t + h = 0$. Or, using the addition formula $\sin(\theta + \alpha) = \sin \theta \cos \alpha + \cos \theta \sin \alpha$,

$$\frac{1}{2}gt^2 - \left[\frac{v_0}{\cos \alpha} \sin(\theta + \alpha) \right]t + h = 0 \tag{1}$$

For a minimum t , we must have $dt/d\theta = 0$. Differentiating (1) with respect to θ and setting $dt/d\theta = 0$, we obtain

$$-\left[\frac{v_0}{\cos \alpha} \cos(\theta + \alpha) \right]t_{\min} = 0$$

which implies that (since $t_{\min} \neq 0$) $\cos(\theta + \alpha) = 0$, or $\theta = 90^\circ - \alpha$.

This result means that the projectile should be aimed in the direction of minimum distance, just as though the acceleration of gravity did not exist. However, gravity cannot be ignored in this problem. If we seek to determine the value of t_{\min} by substituting $\theta + \alpha = 90^\circ$ into (1) and solving, we obtain

$$t_{\min} = \frac{v_0 - \sqrt{v_0^2 - 2gh \cos^2 \alpha}}{g \cos \alpha}$$

which is complex if $v_0 < \sqrt{2gh} \cos \alpha$. In other words, if $v_0 < \sqrt{2gh} \cos \alpha$, the projectile never reaches the roof, whatever the value of θ , and the concept of a minimum time becomes meaningless.

- 5.37** With reference to Fig. 5-18, the projectile is fired with an initial velocity $v_0 = 35$ m/s at an angle $\theta = 23^\circ$. The truck is moving along X with a constant speed of 15 m/s. At the instant the projectile is fired, the back of the truck is at $x = 45$ m. Find the time for the projectile to strike the back of the truck, if the truck is very tall.

| In this case, the projectile hits the back of the truck at the moment of overtaking it, which is the moment at which the distance of the back of the truck, $x_1 = 45 + 15t$, equals the horizontal distance of the projectile, $x = (v_0 \cos \theta)t = 32.22t$.

Thus
$$t = \frac{45}{32.22 - 15} = \underline{2.614 \text{ s}}$$

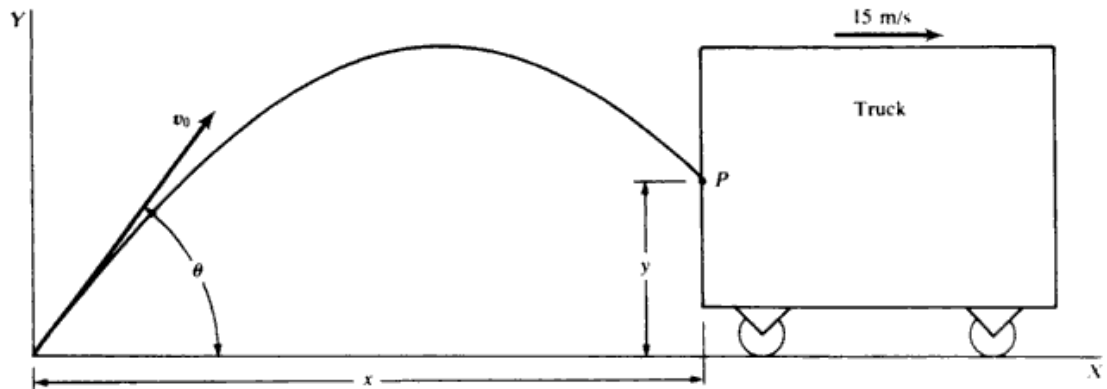

Fig. 5-18

- 5.38** What will happen if the truck of Prob. 5.37 is only 2.0 m tall?

| At $t = 2.614$ s, when the projectile overtakes the back of the truck, its height is, noting $v_0 \sin \theta = 13.67$ m/s: $y = (13.67)(2.614) - \frac{1}{2}(9.8)(2.614)^2 = 2.25$ m, i.e., 25 cm above the top of the truck. Since the projectile travels faster horizontally than does the truck, it is clear that thereafter the projectile remains ahead of the back of the truck, and so never hits the back.

The projectile will reach (for the second time) a height of 2 m in a total time t_2 given by $2 = (13.67)t_2 - \frac{1}{2}(9.8)t_2^2$, or $t_2 = 2.635$ s, that is, $2.635 - 2.614 = 0.021$ s after overtaking the back of the truck. Thus the projectile hits the top of the truck of a distance of $(32.22 - 15)(0.021) = 0.36$ m = 36 cm in front of the rear edge.

- 5.39** Referring to Prob. 5.37, find a value of v_0 , all other conditions remaining the same, for which the projectile hits the truck at $y = 3$ m.

| The time taken to overtake the back of the truck is given by

$$45 + 15t = (v_0 \cos \theta)t \quad \text{or} \quad t = \frac{45}{v_0 \cos \theta - 15}$$

at which time $y = 3 = (v_0 \sin \theta)t - \frac{1}{2}(9.8)t^2 = (v_0 \sin \theta)\left(\frac{45}{v_0 \cos \theta - 15}\right) - \frac{1}{2}(9.8)\left(\frac{45}{v_0 \cos \theta - 15}\right)^2$

Inserting the numerical values of $\sin \theta$ and $\cos \theta$, we obtain the following quadratic equation for v_0 : $v_0^2(4.55) - v_0(60.3) - 3532 = 0$. Solving, $v_0 = \underline{35.3 \text{ m/s}}$.

- 5.40*** The motion of a particle in the XY plane is given by $x = 25 + 6t^2$; $y = -50 - 20t + 8t^2$. Find the following initial values: $x_0, y_0, \dot{x}_0, \dot{y}_0, v_0$.

| At $t = 0$, $x = x_0 = 25$ m; $y = y_0 = -50$ m.

$$v_x = \dot{x} = 12t \quad \text{and} \quad v_{0x} = \dot{x}_0 = 0 \text{ m/s} \quad v_y = \dot{y} = -20 + 16t \quad \text{and} \quad v_{0y} = \dot{y}_0 = -20 \text{ m/s}$$

$$v_0 = (v_{0x}^2 + v_{0y}^2)^{1/2} = \underline{20 \text{ m/s}}$$

- 5.41^c Find magnitude and direction of \mathbf{a} , the acceleration of the particle in Prob. 5.40.

$$\blacksquare \quad a_x = \dot{v}_x = 12 \text{ m/s}^2; \quad a_y = \dot{v}_y = 16 \text{ m/s}^2.$$

$$\tan \theta_a = \frac{a_y}{a_x} = \frac{16}{12} = \frac{4}{3}$$

implies that $\theta_a = 53^\circ$ above the positive x axis. $a = (12^2 + 16^2)^{1/2} = 20 \text{ m/s}^2$.

- 5.42 Write an equation for the particle's path (find y as a function of x) in Prob. 5.40.

\blacksquare We eliminate time between the two equations as follows: $t^2 = (x - 25)/6$, or $t = [(x - 25)/6]^{1/2}$. Then substituting into the y equation: $y = -50 - 20[(x - 25)/6]^{1/2} + 8(x - 25)/6$, or $6y = -500 + 8x - 120[(x - 25)/6]^{1/2}$.

- 5.43^c A particle moving in the XY plane has X and Y components of velocity given by

$$\dot{x} = b_1 + c_1 t \quad \dot{y} = b_2 + c_2 t \quad (1)$$

where x and y are measured in meters and t in seconds. (a) What are the units and dimensions of the constants b_1 and b_2 ? of c_1 and c_2 ? (b) Integrate the above relations to obtain x and y as functions of time. (c) Denoting total acceleration as \mathbf{a} and total velocity as \mathbf{v} , find expressions for the magnitude and direction of \mathbf{a} and of \mathbf{v} . (d) Write \mathbf{v} in terms of the unit vectors.

\blacksquare (a) Inspection of (1) shows that b_1 and b_2 must represent velocities in meters per second; unit-dimensionally c_1 and c_2 must be $|\text{m/s}^2|$, thus accelerations.

$$(b) \quad x = x_0 + b_1 t + \frac{1}{2} c_1 t^2 \quad y = y_0 + b_2 t + \frac{1}{2} c_2 t^2$$

where x_0, y_0 are the values of x and y at $t = 0$.

(c) Differentiating (1) with respect to t , $\ddot{x} = c_1$, $\ddot{y} = c_2$. Then

$$a = (\ddot{x}^2 + \ddot{y}^2)^{1/2} = (c_1^2 + c_2^2)^{1/2} \quad \tan \alpha = \frac{\ddot{y}}{\ddot{x}} = \frac{c_2}{c_1}$$

where α is the angle \mathbf{a} makes with X . Note that \mathbf{a} is constant in magnitude and direction. For the velocity,

$$v = (\dot{x}^2 + \dot{y}^2)^{1/2} = [(b_1 + c_1 t)^2 + (b_2 + c_2 t)^2]^{1/2} \quad \tan \beta = \frac{b_2 + c_2 t}{b_1 + c_1 t}$$

where β is the angle \mathbf{v} makes with X . (d) $\mathbf{v} = (b_1 + c_1 t)\mathbf{i} + (b_2 + c_2 t)\mathbf{j}$.

- 5.44^c A particle moves in the XY plane along the path given by $y = 10 + 3x + 5x^2$. The X component of velocity, $\dot{x} = 4 \text{ m/s}$, is constant, and at $t = 0$, $x = x_0 = 6 \text{ m}$. (a) Write y and x as functions of t . (b) Find \ddot{y} and \ddot{x} , the components of acceleration of the particle.

\blacksquare (a) $\dot{y} = 3\dot{x} + 10x\dot{x}$; $\dot{x} = 4 \text{ m/s}$ at all times and $x_0 = 6 \text{ m}$. Then

$$x = x_0 + \dot{x}t = 6 \text{ m} + (4 \text{ m/s})t.$$

$$y = 10 + (18 + 12t) + 5(6 + 4t)^2 = 208 \text{ m} + (252 \text{ m/s})t + (80 \text{ m/s}^2)t^2$$

$$(b) \quad \ddot{x} = 0 \quad \ddot{y} = 160 \text{ m/s}^2$$

- 5.45 A ball, B_1 , is fired upward from the origin of X, Y with initial velocity $v_1 = 100 \text{ m/s}$ at an angle $\theta_1 = 40^\circ$. After $t_1 = 10 \text{ s}$, as can easily be shown, the ball is at point $P(x_1, y_1)$, where $x_1 = 766.0 \text{ m}$, $y_1 = 152.8 \text{ m}$. Some time later, another ball, B_2 , is fired upward, also from the origin, with velocity v_2 at angle $\theta_2 = 35^\circ$. (a) Find a value of v_2 such that B_2 will pass through the point $P(x_1, y_1)$. (b) Find the time when B_2 must be fired in order that the two balls will collide at $P(x_1, y_1)$.

\blacksquare (a) Let (x_1, y_1, t_1) refer to the coordinates and time of B_1 and (x_2, y_2, t_2) to those of B_2 . Since B_2 is to pass through $P(x_1, y_1)$,

$$x_2 = (v_2 \cos 35^\circ)t_2 = 766.0 \quad y_2 = (v_2 \sin 35^\circ)t_2 - 4.9t_2^2 = 152.8$$

Eliminating t_2 ,

$$152.8 = (766.0) \tan 35^\circ - (4.9) \left(\frac{766.0}{v_2 \cos 35^\circ} \right)^2$$

from which $v_2 = 105.69 \text{ m/s}$.

(b) Inserting the value of v_2 in $x_2 = (v_2 \cos 35^\circ)t_2 = 766.0$ m, we find $t_2 = 8.848$ s. Hence, with $v_2 = 105.69$ m/s and $\theta_2 = 35^\circ$, B_2 passes through $P(x_1, y_1)$ 8.848 s after it is fired. But B_1 arrives at this point 10 s after starting. Hence, if the two are to collide, the firing of B_2 must be delayed $10 - 8.848 = 1.152$ s.

5.46^c The motion of a particle in the XY plane is given by

$$x = 10 + 12t - 20t^2 \quad y = 25 + 15t + 30t^2$$

Find values of $x_0, \dot{x}_0, y_0, \dot{y}_0$ and the magnitude and direction of \mathbf{v}_0 .

▮ At $t = 0, x = x_0 = 10; y = y_0 = 25$. Differentiating we get $\dot{x} = 12 - 40t; \dot{y} = 15 + 60t; \dot{x}_0 = 12; \dot{y}_0 = 15$.

$$v_0 = (\dot{x}_0^2 + \dot{y}_0^2)^{1/2} = 19.2 \quad \theta_0 = \tan^{-1} \frac{\dot{y}_0}{\dot{x}_0} = 51.3^\circ \quad \text{above positive } x \text{ axis}$$

5.47^c Referring to Prob. 5.46, find \ddot{x}, \ddot{y} , and \mathbf{a} , the vector acceleration.

▮ We differentiate the expressions for \dot{x} and \dot{y} to get $\ddot{x} = -40, \ddot{y} = 60$. Acceleration is thus constant and $a = \sqrt{40^2 + 60^2} = 72$. The direction of \mathbf{a} is given by

$$\beta = \tan^{-1} \left| \frac{60}{40} \right| = 56.3^\circ \quad \text{above the negative } x \text{ axis}$$

5.48 Referring to Probs. 5.46 and 5.47, state whether or not the motion is along a straight line.

▮ No: Since the lines of \mathbf{v}_0 and \mathbf{a} do not coincide the path must be parabolic, as in projectile motion. See Prob. 5.57.

5.49^c Can the motion of a particle be given by

$$x = 5 + 10t + 17t^2 + 4t^3 \quad y = 8 + 9t + 20t^2 - 6t^3$$

if the particle is acted on by a constant force?

▮ $\dot{x} = 10 + 34t + 12t^2; \dot{y} = 9 + 40t - 18t^2; \ddot{x} = 34 + 24t; \ddot{y} = 40 - 36t$. But the acceleration is not constant, as it must be for a constant force. Hence, the motion is impossible.

5.2 RELATIVE MOTION

5.50 An elevator is moving upward at a constant speed of 4 m/s. A light bulb falls out of a socket in the ceiling of the elevator. A man in the building watching the cage sees the bulb rise for $(4/9.8)$ s and then fall for $(4/9.8)$ s; at $t = (4/9.8)$ s the bulb appears to be at rest to the man. Compute the velocity of the bulb at $t = (4/9.8)$ s from the view of an observer in the elevator.

▮ Taking up as positive $v_{\text{bulb/elev}} = v_{\text{bulb/bldg}} - v_{\text{elev/bldg}} = 0 - 4 = -4$ m/s. Alternatively, in the inertial frame of the elevator,

$$v = v_0 + at = 0 + (-9.8) \left(\frac{4}{9.8} \right) = -4 \text{ m/s}$$

5.51 A ship is traveling due east at 10 km/h. What must be the speed of a second ship heading 30° east of north if it is always due north from the first ship?

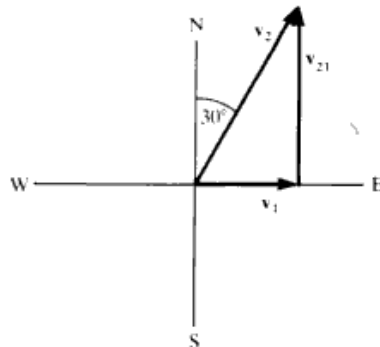

Fig. 5-19

▮ \mathbf{v}_1 = velocity of first ship relative to the earth; \mathbf{v}_2 = velocity of second ship relative to the earth. Let \mathbf{v}_{21} = relative velocity of second ship to first ship. Then $\mathbf{v}_2 = \mathbf{v}_{21} + \mathbf{v}_1$, (Fig. 5-19), where \mathbf{v}_{21} is due north. Thus $v_2 \sin 30^\circ = v_1 = 10 \text{ km/h}$, and $v_2 = 20 \text{ km/h}$.

5.52 During a rainstorm, raindrops are observed to be striking the ground at an angle of 35° with the vertical. The wind speed is 4.5 m/s . Assuming that the horizontal velocity component of the raindrops is the same as the speed of the air, what is the vertical velocity component of the raindrops? What is their speed?

▮ Let \mathbf{v} = velocity of raindrops relative to earth, \mathbf{v}_w = wind velocity, $v_w = 4.5 \text{ m/s}$, $v_x = v_w$. From Fig. 5-20,

$$v_y = \frac{v_w}{\tan 35^\circ} = 6.43 \text{ m/s} \quad v = \sqrt{v_x^2 + v_y^2} = 7.84 \text{ m/s}$$

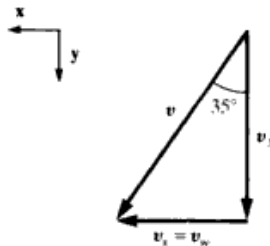

Fig. 5-20

5.53 A rowboat is pointing perpendicular to the bank of a river. The rower can propel the boat with a speed of 3.0 m/s with respect to the water. The river has a current of 4.0 m/s . (a) Construct a diagram in which the two velocities are represented as vectors. (b) Find the vector which represents the boat's velocity with respect to the shore. (c) At what angle is this vector inclined to the direction in which the boat is pointing? What is the boat's speed with respect to the launch point? (d) If the river is 100 m wide, determine how far downstream of the launch point the rowboat is when it reaches the opposite bank.

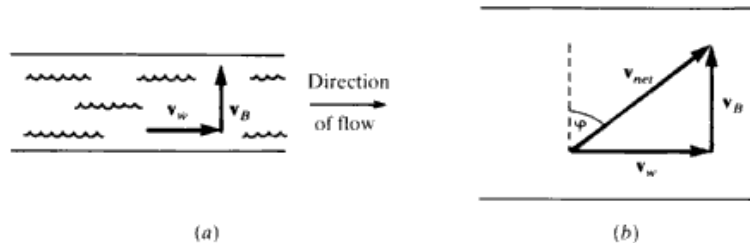

Fig. 5-21

▮ (a) See Fig. 5-21(a).

(b, c) The velocity with respect to the shore is given by $\mathbf{v}_{net} = \mathbf{v}_B + \mathbf{v}_w$. Since \mathbf{v}_B and \mathbf{v}_w are perpendicular, we have $v_{net} = \sqrt{v_B^2 + v_w^2} = \sqrt{3^2 + 4^2} = 5 \text{ m/s}$. The angle φ shown in Fig. 5-21(b) is determined by $\tan \varphi = v_w/v_B$. For the speeds given, we find $\varphi = 53.1^\circ$. The boat moves along a line directed 53.1° downstream from "straight across."

(d) Letting D = distance downstream, we have $D/100 \text{ m} = v_w/v_B = 4/3$, so that $D = 133 \text{ m}$.

5.54 A swimmer can swim at a speed of 0.70 m/s with respect to the water. She wants to cross a river which is 50 m wide and has a current of 0.50 m/s . (a) If she wishes to land on the other bank at a point directly across the river from her starting point, in what direction must she swim? How rapidly will she increase her distance from the near bank? How long will it take her to cross? (b) If, she instead decides to cross in the shortest possible time, in what direction must she swim? How rapidly will she increase her distance from the near bank? How long will it take her to cross? How far downstream will she be when she lands?

▮ (a) Let \mathbf{v}_c be the velocity of the current, \mathbf{v}_w be the velocity of the swimmer with respect to the water, and \mathbf{v}_s be the velocity of the swimmer with respect to the shore. Then $\mathbf{v}_s = \mathbf{v}_w + \mathbf{v}_c$. For a direct crossing, \mathbf{v}_s must be perpendicular to \mathbf{v}_c . Therefore $\sin \theta = v_c/v_w$, as shown in Fig. 5-22. We are given the values $v_c = 0.50 \text{ m/s}$, $v_w = 0.70 \text{ m/s}$, and $d = 50 \text{ m}$; we find $\theta = 45.6^\circ$ upstream from the direction "straight across." The swimmer will increase her distance from the near shore at the rate $v_s = v_w \cos \theta = 0.49 \text{ m/s}$. She will cross the river in a time $t = d/v_s = 102 \text{ s}$.

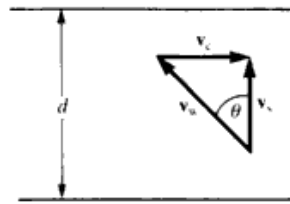

Fig. 5-22

(b) To maximize the component of her velocity perpendicular to the river bank, the swimmer should head straight across the stream. She will cross in a time $t = d/v_w = 71.4$ s, and she will land a distance $v_c t = (v_c/v_w)d = 35.7$ m downstream from her starting point.

5.55 An armored car 2 m long and 3 m wide is moving at 13 m/s when a bullet hits it in a direction making an angle $\arctan(3/4)$ with the car as seen from the street (Fig. 5-23a). The bullet enters one edge of the car at the corner and passes out at the diagonally opposite corner. Neglecting any interaction between bullet and car, find the time for the bullet to cross the car.

▮ Call the speed of the bullet V . Because of the motion of the car, the velocity of the bullet relative to the car in the direction of the length of the car is $V \cos \theta - 13$, and the velocity in the direction of the width of the car is $V \sin \theta$ (Fig. 5-23b). Then, from $s = vt$,

$$2 = (V \cos \theta - 13)t \quad 3 = (V \sin \theta)t$$

Eliminate V to find

$$t = \frac{1}{13} \left(\frac{3}{\tan \theta} - 2 \right) = \frac{2}{13} = 0.15 \text{ s}$$

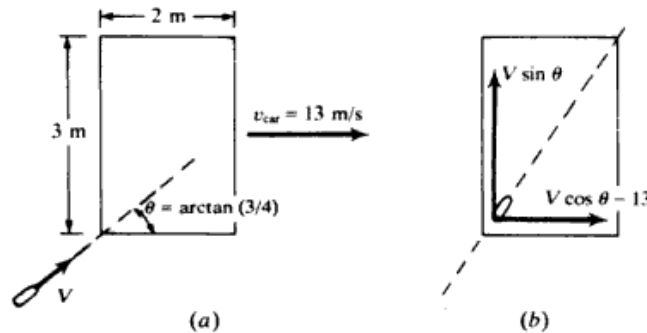

Fig. 5-23

5.56 Rain, pouring down at an angle α with the vertical, has a constant speed of 10 m/s. A woman runs against the rain with a speed of 8 m/s and sees that the rain makes an angle β with the vertical. Find the relation between α and β .

▮ From the vector diagram, Fig. 5-24,

$$\tan \beta = \frac{v_{\text{woman}} + v_{\text{rain}} \sin \alpha}{v_{\text{rain}} \cos \alpha} = \frac{8 + 10 \sin \alpha}{10 \cos \alpha}$$

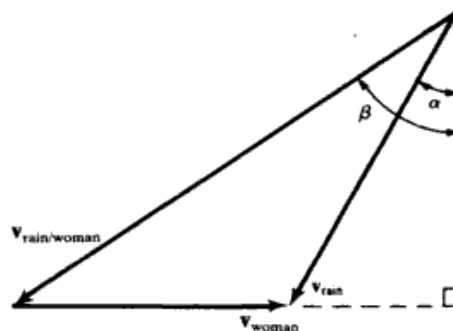

Fig. 5-24

5.57 Verify that the trajectory of Prob. 5.46 is a parabola by choosing coordinate axes parallel and perpendicular to the constant acceleration vector.

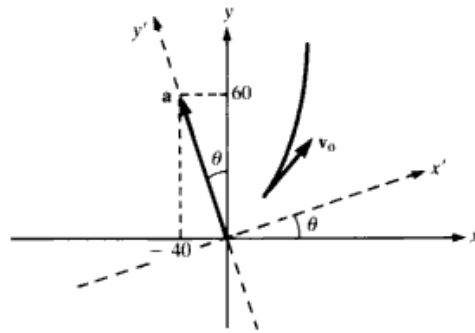

Fig. 5-25

Figure 5-25 shows the new coordinate system; from analytic geometry we have the relations

$$x' = x \cos \theta + y \sin \theta = \frac{3}{\sqrt{13}}x + \frac{2}{\sqrt{13}}y \quad y' = -x \sin \theta + y \cos \theta = -\frac{2}{\sqrt{13}}x + \frac{3}{\sqrt{13}}y$$

Hence the equations of motion in the primed coordinates are

$$\sqrt{13} x' = 3(10 + 12t - 20t^2) + 2(25 + 15t + 30t^2) = 80 + 66t \tag{1}$$

$$\sqrt{13} y' = -2(10 + 12t - 20t^2) + 3(25 + 15t + 30t^2) = 55 + 21t + 130t^2 \tag{2}$$

We can now solve (1) for t in terms of x' and substitute the result in (2), obtaining an equation

$$y' = ax'^2 + bx' + c \tag{3}$$

for definite constants a, b, c . Finally, completing the square on the right of (3), we transform it to

$$y' - \beta = K(x' - \alpha)^2 \tag{4}$$

which is recognized as the equation of a parabola, with vertex at $x' = \alpha, y' = \beta$ and with axis parallel to the y' axis.

5.58 Observer O drops a stone from the thirtieth floor of a skyscraper. Observer O' , descending in an elevator at constant speed $V = 5.0 \text{ m/s}$, passes the thirtieth floor just as the stone is released. At the time $t = 3.0 \text{ s}$ after the stone is dropped, find the position, the velocity, and the acceleration of the stone relative to O . Then find the position, the velocity, and the acceleration of the stone relative to O' .

For O , the position of the stone is given by

$$x = x_0 + v_0 t + \frac{at^2}{2}$$

where $x = 0$ at the thirtieth floor with the downward direction as the positive x direction. Thus, at $t = 3.0 \text{ s}$,

$$x = 0 + 0 + \frac{9.8 \text{ m/s}^2 \times (3.0 \text{ s})^2}{2} = +44 \text{ m}$$

Also, $v = v_0 + at$ gives $v = 0 + 9.8 \text{ m/s}^2 \times 3.0 \text{ s} = +29 \text{ m/s}$.

The acceleration of a freely falling body, as seen by the observer O who is stationary with respect to the earth, is known to be the constant gravitational acceleration. (Indeed, this underlies the validity of the two calculations immediately above.) You thus have $a = +g = +9.8 \text{ m/s}^2$.

O' measures position x' , related to x via $x' = x - Vt$. Hence, after 3.0 s , $x' = 44 \text{ m} - 5.0 \text{ m/s} \times 3.0 \text{ s} = +29 \text{ m}$. That is, the stone is located 29 m below observer O' at the end of 3.0 s . The stone's velocity relative to O' is $v' = v - V$; hence, at $t = 3.0 \text{ s}$,

$$v' = 29 \text{ m/s} - 5.0 \text{ m/s} = +24 \text{ m/s}$$

Since V is constant, $\mathbf{a}' = \mathbf{a}$, and $a' = +g = +9.8 \text{ m/s}^2$. Observer O' sees the stone to have the same downward acceleration as that seen by O . (In general, accelerations are the same in all inertial frames.)

- 5.59** A truck is traveling due north and descending a 10 percent grade (angle of slope = $\tan^{-1} 0.10 = 5.7^\circ$) at a constant speed of 90 km/h. At the base of the hill there is a gentle curve, and beyond that the road is level and heads 30° east of the north. A southbound police car with a radar unit is traveling at 80 km/h along the level road at the base of the hill, approaching the truck. What is the velocity vector of the truck with respect to the police car?

| We use coordinate axes with \hat{x} east, \hat{y} north, and \hat{z} vertically upward. We let \mathbf{v}_T be the velocity of the truck with respect to the ground and \mathbf{v}_P be the velocity of the police car with respect to the ground. According to the information given, we have

$$\begin{aligned}\mathbf{v}_T &= 0\hat{x} + (90 \text{ km/h})(\cos 5.7^\circ)\hat{y} - (90 \text{ km/h})(\sin 5.7^\circ)\hat{z} \quad \text{and} \\ \mathbf{v}_P &= (-80 \text{ km/h})(\sin 30^\circ)\hat{x} - (80 \text{ km/h})(\cos 30^\circ)\hat{y} + 0\hat{z}\end{aligned}$$

Reducing these, we find $\mathbf{v}_T = (89.6\hat{y} - 8.94\hat{z})$ km/h and $\mathbf{v}_P = (-40.0\hat{x} - 69.3\hat{y})$ km/h. The velocity \mathbf{u}_T of the truck with respect to the police car is given by

$$\mathbf{u}_T = \mathbf{v}_T - \mathbf{v}_P = (40.0\hat{x} + 158.8\hat{y} - 8.9\hat{z}) \text{ km/h}$$

- 5.60^c** A bird, in level flight at constant acceleration \mathbf{a}_0 relative to the ground frame X, Y (Fig. 5-26), lets fall a worm from its beak. What is the path of the worm, as seen by the bird?

| In the bird's noninertial coordinate system X', Y' (Fig. 5-26), the equation of motion of the worm is

$$m \frac{d\mathbf{v}'}{dt} = m\mathbf{g} - m\mathbf{a}_0 \quad \text{or} \quad \frac{d\mathbf{v}'}{dt} = \mathbf{g} - \mathbf{a}_0 = \text{constant}$$

Thus the acceleration of the worm is constant, and its path is a straight line (supposing that it was dropped from rest). The slope of the line with respect to the horizontal is $\tan \theta = g/a_0$.

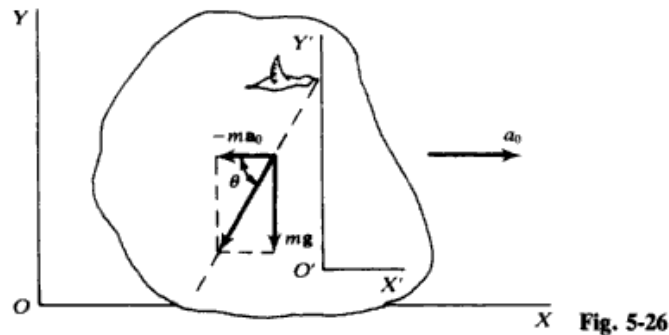

- 5.61^c** Refer to Prob. 5.60 and Fig. 5-26. **(a)** Determine the path of the worm as seen from the ground. **(b)** Verify that the two descriptions of the path are equivalent.

| **(a)** In the ground frame X, Y , the worm has constant acceleration $\ddot{y} = -g$ and an initial velocity $\dot{x}_0 = v_0$, where v_0 is the speed of the bird at the instant the worm is released (call this time $t = 0$). Hence

$$x = x_0 + v_0 t \quad y = y_0 - \frac{1}{2}gt^2 \quad (1)$$

and the path is a parabola.

(b) Let us suppose that at $t = 0$ the two coordinate frames coincide. At time t , O' will have advanced a distance $v_0 t + \frac{1}{2}a_0 t^2$ along the X axis, so that the coordinates (x, y) and (x', y') of the worm in the two systems are related by

$$x = x' + (v_0 t + \frac{1}{2}a_0 t^2) \quad y = y' \quad (2)$$

The path in the X', Y' system is obtained by substituting the expressions (2) into (1):

$$x' + v_0 t + \frac{1}{2}a_0 t^2 = x_0 + v_0 t \quad y' = y_0 - \frac{1}{2}gt^2$$

or

$$\frac{y' - y_0}{x' - x_0} = \frac{g}{a_0}$$

which is a straight line of slope g/a_0 , as found in Prob. 5.60.

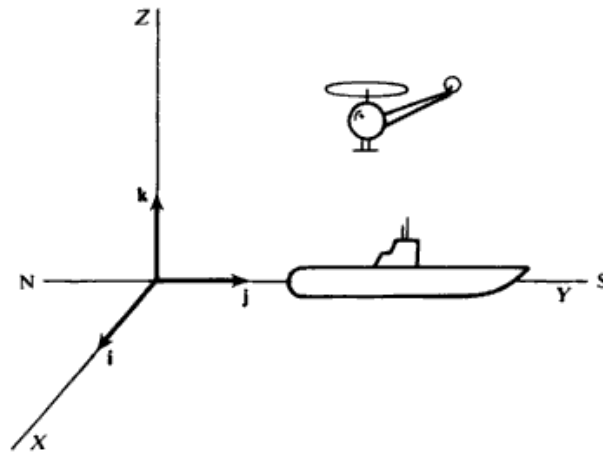

Fig. 5-27

- 5.62** A helicopter is trying to land on a submarine deck which is moving south at 17 m/s. A 12 m/s wind is blowing into the west. If to the submarine crew the helicopter is descending vertically at 5 m/s, what is its speed (a) relative to the water and (b) relative to the air. See Fig. 5-27.

| (a) $\mathbf{v}_{\text{hel/water}} = \mathbf{v}_{\text{sub/water}} + \mathbf{v}_{\text{hel/sub}} = 17\mathbf{j} + (-5)\mathbf{k} = (17\mathbf{j} - 5\mathbf{k}) \quad \text{m/s}$

(b) $\mathbf{v}_{\text{hel/air}} = \mathbf{v}_{\text{hel/water}} + \mathbf{v}_{\text{water/air}} = \mathbf{v}_{\text{hel/water}} - \mathbf{v}_{\text{air/water}} = (17\mathbf{j} - 5\mathbf{k}) - 12\mathbf{i} = (-12\mathbf{i} + 17\mathbf{j} - 5\mathbf{k}) \quad \text{m/s}$

CHAPTER 6

Motion in a Plane II

6.1 CIRCULAR MOTION; CENTRIPETAL FORCE

6.1 A 0.3-kg mass attached to a 1.5 m-long string is whirled around in a horizontal circle at a speed of 6 m/s. (a) What is the centripetal acceleration of the mass? (b) What is the tension in the string? (Neglect gravity.)

| (a)
$$a = \frac{v^2}{R} = \frac{(6 \text{ m/s})^2}{1.5 \text{ m}} = 24 \text{ m/s}^2$$

(b) The tension in the string exerts the centripetal force required to keep the mass in circular motion. This force is $T = ma = (0.3 \text{ kg})(24 \text{ m/s}^2) = 7.2 \text{ N}$.

6.2 A small ball is fastened to a string 24 cm long and suspended from a fixed point P to make a conical pendulum, as shown in Fig. 6-1. The ball describes a horizontal circle about a center vertically under point P , and the string makes an angle of 15° with the vertical. Find the speed of the ball.

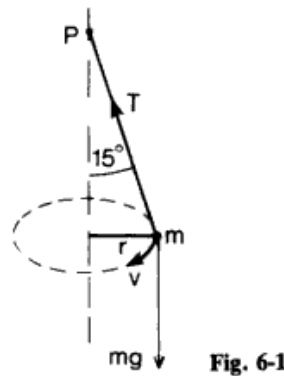

|
$$T \cos 15^\circ = mg \quad T \sin 15^\circ = \frac{mv^2}{r} \quad \text{and hence} \quad \tan 15^\circ = \frac{v^2}{rg}$$

Since $r = 24 \sin 15^\circ = 24(0.259) = 6.22 \text{ cm}$,

$$\tan 15^\circ = \frac{v^2}{6.22(980)} \quad v = 40.4 \text{ cm/s}$$

6.3 In the Bohr model of the hydrogen atom an electron is pictured rotating in a circle (with a radius of $0.5 \times 10^{-10} \text{ m}$) about the positive nucleus of the atom. The centripetal force is furnished by the electric attraction of the positive nucleus for the negative electron. How large is this force if the electron is moving with a speed of $2.3 \times 10^6 \text{ m/s}$? (The mass of an electron is $9 \times 10^{-31} \text{ kg}$.)

| Force = $(9 \times 10^{-31} \text{ kg})(2.3 \times 10^6 \text{ m/s})^2 / (5.0 \times 10^{-11} \text{ m}) = 9.5 \times 10^{-8} \text{ N}$

6.4 Find the maximum speed with which an automobile can round a curve of 80-m radius without slipping if the road is unbanked and the coefficient of friction between the road and the tires is 0.81.

| First draw a diagram showing the forces (Fig. 6-2). If mg is the weight of the automobile, then the normal force is $N = mg$. The frictional force supplies the centripetal force F_c .

$$F_c = \mu_s N = 0.81 mg$$

Also,
$$F_c = \frac{mv^2}{r} \quad 0.81 mg = \frac{mv^2}{80} \quad v^2 = 0.81 \times 80 \times 9.8 = 25.2 \text{ m/s}$$

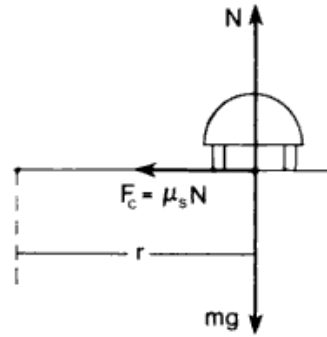

Fig. 6-2

6.5 What is the maximum velocity, in miles per hour, for an automobile rounding a level curve of 200-ft radius if μ_s between tires and roadbed is 1.0.

▮ $\mu_s mg = \frac{mv^2}{r} \quad \mu_s = \frac{v^2}{rg} \quad v = \sqrt{\mu_s rg} = \sqrt{1.0 \times 32.2 \text{ ft/s}^2 \times 200 \text{ ft}} = 80 \text{ ft/s} = 80 \text{ ft/s} \times \frac{30 \text{ mi/h}}{44 \text{ ft/s}} = \underline{54.5 \text{ mi/h}}$

6.6 A car is traveling 25 m/s (56 mi/h) around a level curve of radius 120 m. What is the minimum value of the coefficient of static friction between the tires and the road required to prevent the car from skidding?

▮ $F = m \frac{v^2}{r} = F_f \leq \mu_s mg \quad \mu_s \geq \frac{v^2}{rg} = \frac{(25 \text{ m/s})^2}{(9.8 \text{ m/s}^2)(120 \text{ m})} = \underline{0.53}$

6.7 Traffic is expected to move around a curve of radius 200 m at 90 km/h. What should be the value of the banking angle if no dependence is to be placed on friction?

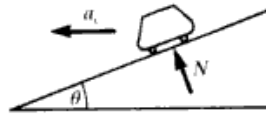

Fig. 6-3

▮ See Fig. 6-3. $w = mg = N \cos \theta \quad \text{and} \quad F_c = \frac{mv^2}{r} = N \sin \theta$

Dividing the second by the first equation, $\tan \theta = v^2/rg$. Substitute the data, changing kilometers per hour into meters per second:

$$\tan \theta = \frac{\left(\frac{90 \text{ km/h} \times 1000 \text{ m/km}}{3600 \text{ s/h}}\right)^2}{200 \text{ m} \times 9.8 \text{ m/s}^2} = 0.319 \quad \text{so} \quad \theta = \underline{17.7^\circ}$$

6.8 As indicated in Fig. 6-4, a plane flying at constant speed is banked at angle θ in order to fly in a horizontal circle of radius r . The aerodynamic lift force acts generally upward at right angles to the plane's wings and fuselage. This lift force corresponds to the tension provided by the string in a conical pendulum, or the normal force of a banked road. (a) Obtain the equation for the required banking angle θ in terms of v , r , and g . (b) What is the required angle for $v = 60 \text{ m/s}$ (216 km/h) and $r = 1.0 \text{ km}$?

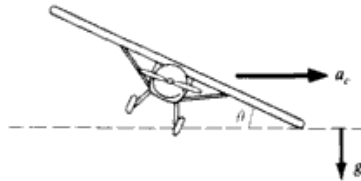

Fig. 6-4

▮ (a) As in Probs. 6.2 and 6.7, $\tan \theta = v^2/rg$.

(b) $\theta = \tan^{-1} \frac{60^2}{(1.0 \times 10^3)(9.8)} = \underline{20.2^\circ}$

- 6.9** A car goes around a curve of radius 48 m. If the road is banked at an angle of 15° with the horizontal, at what maximum speed in kilometers per hour may the car travel if there is to be no tendency to skid even on very slippery pavement?

▮ Use the equation for banking of highways:

$$\tan \theta = \frac{v^2}{rg} \quad \tan 15^\circ = \frac{v^2}{48(9.8)}$$

$$v = 0.268(48)(9.8) = 11.2 \text{ m/s} = (11.2 \text{ m/s})(0.001 \text{ km/m})(3600 \text{ s/h}) = \underline{40.3 \text{ km/h}}$$

- 6.10** A certain car of mass m has a maximum frictional force of $0.7 mg$ between it and pavement as it rounds a curve on a flat road ($\mu = 0.7$). How fast can the car be moving if it is to successfully negotiate a curve of 15-m radius?

▮ The centripetal force (mv^2/r) must be supplied by the frictional force. In the limiting case, $mv^2/r = f$ with $f = 0.7 mg$. Thus, $v^2 = 0.7rg$ and $v = \underline{10 \text{ m/s}}$.

- 6.11** A crate sits on the floor of a boxcar. The coefficient of friction between the crate and the floor is 0.6. What is the maximum speed that the boxcar can go around a curve of radius 200 m without causing the crate to slide?

▮ As in other “unbanked-curve” problems (e.g., Prob. 6.5),

$$v_{\max}^2 = \mu_s gr = (0.6)(9.8 \text{ m/s}^2)(200 \text{ m}) = 1176 \text{ m}^2/\text{s}^2 \quad v_{\max} = \sqrt{1176 \text{ m}^2/\text{s}^2} = \underline{34.3 \text{ m/s}}$$

- 6.12** A boy on a bicycle pedals around a circle of 22-m radius at a speed of 10 m/s. The combined mass of the boy and the bicycle is 80 kg. **(a)** What is the centripetal force exerted by the pavement on the bicycle? **(b)** What is the upward force exerted by the pavement on the bicycle? See Fig. 6-5.

▮ **(a)** $F_c = \frac{mv^2}{r} = \frac{80(10)^2}{22} = 364 \text{ N}$ **(b)** $N = mg = 80(9.8) = \underline{784 \text{ N}}$

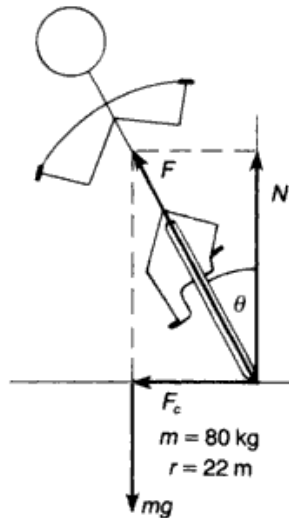

Fig. 6-5

- 6.13** Refer to Prob. 6.12. What is the angle that the bicycle makes with the vertical?

▮ For the bicycle not to fall, the torque about the center of gravity must be zero—see Chaps. 9 and 10—which means that the vector force exerted by the ground must have a line of action passing through the center of gravity. Thus

$$\tan \theta = \frac{F_c}{N} = \frac{364}{784} = 0.4643 \quad \theta = \underline{25^\circ}$$

- 6.14** A fly of mass 0.2 g sits 12 cm from the center of a phonograph record revolving at $33\frac{1}{3}$ rpm. **(a)** What is the

magnitude of the centripetal force on the fly? **(b)** What is the minimum value of the coefficient of static friction between the fly and the record required to prevent the fly from sliding off?

| (a)
$$v = \frac{2\pi r}{T} = 2\pi fr = 2\pi \left(\frac{33.33 \text{ min}^{-1}}{60 \text{ s/min}} \right) (12 \times 10^{-2} \text{ m}) = 0.419 \text{ m/s}$$

$$F = ma = m \frac{v^2}{r} = \frac{(0.2 \times 10^{-3} \text{ kg})(0.419 \text{ m/s})^2}{0.12 \text{ m}} = 2.92 \times 10^{-4} \text{ N}$$

(b)
$$F_f = 2.92 \times 10^{-4} \text{ N} \leq \mu_s mg \quad \mu_s \geq \frac{2.92 \times 10^{-4} \text{ N}}{(0.2 \times 10^{-3} \text{ kg})(9.8 \text{ m/s}^2)} = 0.149$$

6.15 Find **(a)** the speed and **(b)** the period of a spaceship orbiting around the moon. The moon's radius is $1.74 \times 10^6 \text{ m}$, and the acceleration due to gravity on the moon is 1.63 m/s^2 . (Assume that the spaceship is orbiting just above the moon's surface.)

| (a)
$$\frac{v^2}{R_m} = \frac{GM_m}{R_m^2} = g_m \quad v = \sqrt{g_m R_m} = \sqrt{(1.63 \text{ m/s}^2)(1.74 \times 10^6 \text{ m})} = 1.68 \times 10^3 \text{ m/s} = \underline{1.68 \text{ km/s}}$$

(b) The circumference of the orbit is

$$d = 2\pi R_m = (6.28)(1.74 \times 10^6 \text{ m}) = 1.09 \times 10^4 \text{ km}$$

so the period is

$$t = \frac{d}{v} = \frac{1.09 \times 10^4 \text{ km}}{1.68 \text{ km/s}} = 6.5 \times 10^3 \text{ s} = \underline{108 \text{ min}}$$

6.16 At the equator, the effective value of g is smaller than at the poles. One reason for this is the centripetal acceleration due to the earth's rotation. The magnitude of the centripetal acceleration must be subtracted from the magnitude of the acceleration due purely to gravity in order to obtain the effective value of g .

(a) Calculate the fractional diminution of g at the equator as a result of the earth's rotation. Express your result as a percentage. **(b)** How short would the earth's period of rotation have to be in order for objects at the equator to be "weightless" (that is, in order for the effective value of g to be zero)? **(c)** How would the period found in part **(b)** compare with that of a satellite skimming the surface of an airless earth?

| (a) Using $R_e = 6.37 \times 10^6 \text{ m}$ and $T = 24 \text{ h} = 86400 \text{ s}$, we find $a = v^2/R_e = 4\pi^2 R_e/T^2 = 3.37 \times 10^{-2} \text{ m/s}^2$. Therefore $a/g = 3.44 \times 10^{-3}$. Since $g_{\text{eff}} = g - a$, the fractional diminution is $(g - g_{\text{eff}})/g = a/g = \underline{0.344 \text{ percent}}$.

(b) In order that $g_{\text{eff}} = 0$, we need $a = g = 4\pi^2 R_e/T_1^2$. Solving for T_1 , we find $T_1 = 2\pi\sqrt{R_e/g} = 5.06 \times 10^3 \text{ s} = \underline{84.4 \text{ min}}$. **(c)** Since an orbiting satellite has $ma = mg$ and $g_{\text{eff}} = 0$, its period equals T_1 .

6.17 A particle is to slide along the horizontal circular path on the inside of the funnel shown in Fig. 6-6. The surface of the funnel is frictionless. How fast must the particle be moving (in terms of r and θ) if it is to execute this motion?

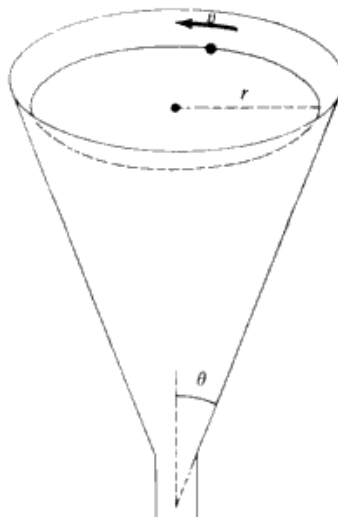

Fig. 6-6

▮ The funnel is equivalent to a road banked at an angle $90^\circ - \theta$. Hence $v^2/rg = \tan(90^\circ - \theta) = \cot \theta$, or $v = \sqrt{rg \cot \theta}$.

- 6.18 An automobile moves around a curve of radius 300 m at a constant speed of 60 m/s [Fig. 6-7(a)]. (a) Calculate the resultant change in velocity (magnitude and direction) when the car goes around the arc of 60° . (b) Compare the magnitude of the instantaneous acceleration of the car to the magnitude of the average acceleration over the 60° arc.

▮ (a) From Fig. 6-7(b), $\Delta v = 60 \text{ m/s}$ and Δv makes a 120° angle with v_A . (b) The instantaneous acceleration has magnitude

$$a = \frac{v^2}{r} = \frac{60^2}{300} = 12 \text{ m/s}^2$$

The time average acceleration is $\bar{a} = \Delta v / \Delta t$. Since

$$\Delta t = \frac{\Delta s}{v} = \frac{r \Delta \theta}{v} = \frac{300(\pi/3)}{60} = \frac{5\pi}{3} \text{ s}$$

we have

$$\bar{a} = \frac{\Delta v}{\Delta t} = \frac{60}{5\pi/3} = 11.5 \text{ m/s}^2$$

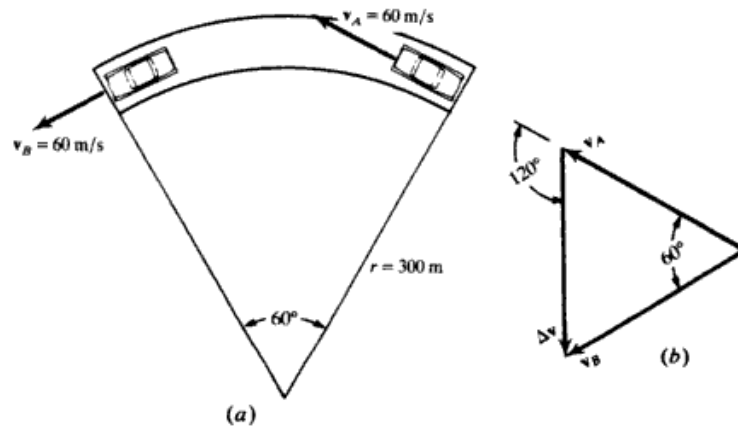

Fig. 6-7

- 6.19 While driving around a curve of 200 m radius, an engineer notes that a pendulum in the car hangs at an angle of 15° to the vertical. What should the speedometer read (in kilometers per hour)?

▮ $T \sin \theta = \frac{mv^2}{r}$; $T \cos \theta = mg$ where $T =$ tension. Thus $\tan \theta = \frac{v^2}{rg}$ or $v = \sqrt{rg \tan \theta} = 23 \text{ m/s} = 82.5 \text{ km/h}$

- 6.20 The bug shown in Fig. 6-8(a) has just lost its footing near the top of the stationary bowling ball. It slides down the ball without appreciable friction. Show that it will leave the surface of the ball at the angle $\theta = \arccos \frac{2}{3} \approx 48^\circ$.

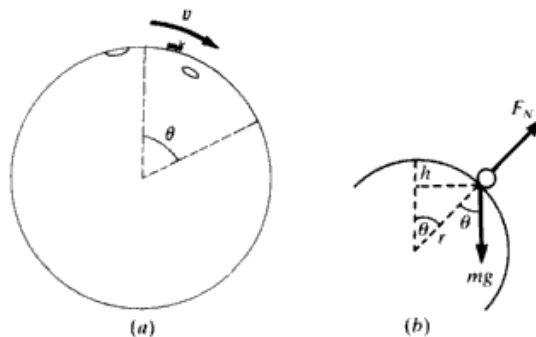

Fig. 6-8

▮ The centripetal force is given by

$$mv^2/r = mg \cos \theta - F_N \quad (1)$$

At angle θ , the decrease in potential energy, $mgh = mgr(1 - \cos \theta)$, must equal the increase in kinetic energy, $mv^2/2$; hence,

$$\frac{mv^2}{r} = 2mg(1 - \cos \theta) \quad (2)$$

Together, (1) and (2) give

$$3mg \cos \theta - F_N = 2mg \quad (3)$$

At the instant the bug loses contact with the ball, $F_N = 0$ and (3) yields $\cos \theta = \frac{2}{3}$.

- 6.21** A 180-lb pilot is executing a vertical loop of radius 2000 ft at 350 mi/h. With what force does the seat press upward against him at the bottom of the loop?

▮
$$F - mg = \frac{mv^2}{r} \quad \text{or} \quad F = \frac{mv^2}{r} + mg$$

First we change miles per hour to feet per second:

$$350 \text{ mi/h} = 513 \text{ ft/s}$$

Substitute values:

$$F = \frac{180 \text{ lb} \times (513 \text{ ft/s})^2}{32.2 \text{ ft/s}^2 \times 2000 \text{ ft}} + 180 \text{ lb} = \underline{915 \text{ lb}}$$

- 6.22** How many g 's must the pilot of the preceding problem withstand at the bottom of the loop?

▮ From the centripetal acceleration formula $a_c = v^2/r$. Substituting,

$$a_c = \frac{(513 \text{ ft/s})^2}{2000 \text{ ft}} = 132 \text{ ft/s}^2$$

Dividing this result by g (32.2 ft/s^2), we obtain

$$a_c = \frac{132 \text{ ft/s}^2}{32.2 \text{ ft/s}^2} = \underline{4.1 g}$$

- 6.23** The designer of a roller coaster wishes the riders to experience "weightlessness" as they round the top of one hill. How fast must the car be going if the radius of curvature at the hilltop is 20 m?

▮ To experience weightlessness, the gravitational force mg must exactly equal the required centripetal force mv^2/r . Equating the two and solving for v gives $\underline{14 \text{ m/s}}$.

- 6.24** A huge pendulum consists of a 200-kg ball at the end of a cable 15 m long. If the pendulum is drawn back to an angle of 37° and released, what maximum force must the cable withstand as the pendulum swings back and forth?

▮ The maximum tension will occur at the bottom when the cable must furnish a force $mg + mv^2/r$. To reach the bottom, the mass falls a distance $h = (15 - 15 \cos 37^\circ) = 3.0 \text{ m}$. Its speed there will be $v = (2gh)^{1/2} = (6g)^{1/2}$. Therefore the tension will be $T = 200g + 200(6g)/15 = \underline{2740 \text{ N}}$.

6.2 LAW OF UNIVERSAL GRAVITATION; SATELLITE MOTION

- 6.25** Two 16-lb shot spheres (as used in track meets) are held 2 ft apart. What is the force of attraction between them?

▮ In American engineering units, $16 \text{ lb} \Rightarrow 0.497 \text{ slug}$ and Newton's law of gravitation has the form $F = G[(m_1 m_2)/d^2]$, with $G = 3.44 \times 10^{-8} \text{ lb} \cdot \text{ft}^2/\text{slug}^2$. Thus,

$$F = \left(3.44 \times 10^{-8} \frac{\text{lb} \cdot \text{ft}^2}{\text{slug}^2} \right) \left(\frac{0.497 \text{ slug} \times 0.497 \text{ slug}}{(2 \text{ ft})^2} \right) = \underline{2.12 \times 10^{-9} \text{ lb}}$$

- 6.26 Calculate the force of attraction between two 90-kg spheres of metal spaced so that their centers are 40 cm apart.

▮ In SI units the gravitational constant has the value $G = 6.67 \times 10^{-11} \text{ N} \cdot \text{m}^2/\text{kg}^2$.

$$F = G \frac{m_1 m_2}{r^2} = (6.67 \times 10^{-11}) \frac{90(90)}{(0.40)^2} = \underline{3.38 \times 10^{-6} \text{ N}}$$

- 6.27 Compute the mass of the earth, assuming it to be a sphere of radius 6370 km.

▮ Let M be the mass of the earth, and m the mass of a certain object on the earth's surface. The weight of the object is equal to mg . It is also equal to the gravitational force $G(Mm)/r^2$, where r is the earth's radius. Hence, $mg = G[Mm/r^2]$, from which

$$M = \frac{gr^2}{G} = \frac{(9.8 \text{ m/s}^2)(6.37 \times 10^6 \text{ m})^2}{6.67 \times 10^{-11} \text{ N} \cdot \text{m}^2/\text{kg}^2} = \underline{6.0 \times 10^{24} \text{ kg}}$$

- 6.28 The average density of solids near the surface of the earth is $\rho = 4 \times 10^3 \text{ kg/m}^3$. On the (crude) assumption of a spherical planet of uniform density ρ , calculate the gravitational constant G .

▮ The mass of the spherical earth is given by $m_e = \rho V = \frac{4}{3}\pi\rho R_e^3$. Insert this value into $g = Gm_e/R_e^2$ and solve for G , obtaining:

$$G = \frac{3g}{4\pi\rho R_e} = \frac{3 \times 9.8 \text{ m/s}^2}{4\pi \times 4 \times 10^3 \text{ kg/m}^3 \times 6.4 \times 10^6 \text{ m}} = \underline{9 \times 10^{-11} \text{ N} \cdot \text{m}^2/\text{kg}^2}$$

This calculation most certainly overestimates G , since ρ (and hence m_e) are underestimates.

- 6.29 A mass $m_1 = 1 \text{ kg}$ weighs one-sixth as much on the surface of the moon as on the earth. Calculate the mass m_2 of the moon. The radius of the moon is $1.738 \times 10^6 \text{ m}$.

▮ On the moon, m_1 weighs $\frac{1}{6}(9.8 \text{ N})$.

$$w_1 = G \frac{m_1 m_2}{r^2} \quad \frac{1}{6}(9.8) = 6.67 \times 10^{-11} \frac{1 \times m_2}{(1.738 \times 10^6)^2}$$

$$m_2 = \frac{(9.8)(1.738 \times 10^6)^2}{(6)(6.67 \times 10^{-11})} = \underline{7.4 \times 10^{22} \text{ kg}}$$

- 6.30 The earth's radius is about 6370 km. An object that has a mass of 20 kg is taken to a height of 160 km above the earth's surface. (a) What is the object's mass at this height? (b) How much does the object weigh (i.e., how large a gravitational force does it experience) at this height?

▮ (a) The mass is the same as that on the earth's surface. (b) As long as we are outside the earth's surface, the weight (force of gravity) varies inversely as the square of the distance from the center of the earth. Indeed $w = GmM/r^2$, where m , M are the masses of object and earth, respectively, and r is the distance to the center of the earth. Thus $w_2/w_1 = r_1^2/r_2^2$, since G , m , M are constant in this problem. For our case we set $r_1 = 6370 \text{ km}$ and $r_2 = 6530 \text{ km}$ and $w_1 = (20 \text{ kg})(9.8 \text{ m/s}^2) = 196 \text{ N}$. This gives $w_2 = \underline{186.5 \text{ N}}$. Note that we could use the fact that $w = mg$ and that m is constant to find the acceleration of gravity at the two heights. That is, $g_2/g_1 = r_1^2/r_2^2$.

- 6.31 The radius of the earth is about 6370 km, while that of Mars is about 3440 km. If an object weighs 200 N on earth, what would it weigh, and what would be the acceleration due to gravity on Mars? Mars has a mass 0.11 that of earth.

▮ Newton's law of gravitation, $w = GmM/r^2$, gives $w_2/w_1 = (M_2/M_1)(r_1^2/r_2^2)$. Letting 1 refer to earth and 2 refer to Mars, we have $w_2 = 0.11(6370/3440)^2(200 \text{ N}) = \underline{75 \text{ N}}$. The acceleration is gotten from $w_2/w_1 = g_2/g_1$, or $g_2 = (75/200)(9.8 \text{ N}) = \underline{3.7 \text{ m/s}^2}$.

- 6.32 The moon orbits the earth in an approximately circular path of radius $3.8 \times 10^8 \text{ m}$. It takes about 27 days to complete one orbit. What is the mass of the earth as obtained from these data?

▮ The gravitational attraction between the earth and moon provides the centripetal force; therefore, $mv^2/r = GmM/r^2$, where M is the earth's mass. Then $M = v^2 r/G = \omega^2 r^3/G$. Now $\omega = 1 \text{ rev}/27 \text{ days} = 2.7 \times 10^{-6} \text{ rad/s}$, $r = 3.8 \times 10^8 \text{ m}$, and $G = 6.7 \times 10^{-11}$ in SI. Solving for M , it is $\underline{6.0 \times 10^{24} \text{ kg}}$. (Compare Prob. 6.27.)

- 6.33** The sun's mass is about 3.2×10^5 times the earth's mass. The sun is about 400 times as far from the earth as the moon is. What is the ratio of the magnitude of the pull of the sun on the moon to that of the pull of the earth on the moon? It may be assumed that the sun–moon distance is constant and equal to the sun–earth distance.)

| Let m denote the moon's mass, M_s the sun's mass, M_e the earth's mass, r_{ms} the center-to-center distance from the sun to the moon, and r_{me} the center-to-center distance from the earth to the moon. We let F_{ms} denote the magnitude of the gravitational force exerted on the moon by the sun, and F_{me} denote the magnitude of the gravitational force exerted on the moon by the earth. Then $F_{ms} = GM_s m/r_{ms}^2$ and $F_{me} = GM_e m/r_{me}^2$, so that

$$\frac{F_{ms}}{F_{me}} = \frac{M_s r_{me}^2}{M_e r_{ms}^2}$$

Using the given numerical values, we find $F_{ms}/F_{me} = 2$.

- 6.34** Estimate the size of a rocky sphere with a density of 3.0 g/cm^3 from the surface of which you could just barely throw away a golf ball and have it never return. (Assume your best throw is 40 m/s .)

| The escape speed v_0 from a sphere of radius R and mass M is given by the energy-conservation equation

$$\frac{1}{2} m v_0^2 = \frac{GmM}{R}$$

Substitution of $M = \rho \frac{4}{3} \pi R^3$ and solution for R gives

$$R = v_0 \sqrt{\frac{3}{8\pi G\rho}}$$

If $\rho = 3 \times 10^3 \text{ kg/m}^3$, then $R = 0.77 \times 10^3 v_0$, where R is in meters and v_0 is in meters per second. Estimating the highest speed at which a human can throw a golf ball as about 40 m/s , we find $R \approx 3 \times 10^4 \text{ m} = \underline{30 \text{ km}}$.

- 6.35** Newton, without knowledge of the numerical value of the gravitational constant G , was nevertheless able to calculate the ratio of the mass of the sun to the mass of any planet, provided the planet has a moon.
(a) Show that for a circular orbits

$$\frac{M_s}{M_p} = \left(\frac{R_p}{R_m}\right)^3 \left(\frac{T_m}{T_p}\right)^2$$

where M_s is the mass of the sun, M_p the mass of the planet, R_p the distance of the planet from the sun, R_m the distance of the moon from the planet, T_m the period of the moon around the planet, and T_p the period of the planet around the sun. (b) If the planet is the earth, $R_p = 1.50 \times 10^8 \text{ km}$, $R_m = 3.85 \times 10^5 \text{ km}$, $T_m = 27.3 \text{ days}$, and $T_p = 365.2 \text{ days}$. Calculate M_s/M_p .

| (a) Applying Newton's second law and the law of gravitation to each orbit, we find (expressing centripetal force in terms of period, T , using $v = 2\pi R/T$),

$$\frac{4\pi^2 M_p R_p}{T_p^2} = \frac{G M_s M_p}{R_p^2} \quad \text{and} \quad \frac{4\pi^2 m R_m}{T_m^2} = \frac{G M_p m}{R_m^2}$$

where m is the mass of the satellite. Solving the above equations for M_s/M_p , we obtain

$$\frac{M_s}{M_p} = \frac{(4\pi^2 R_p^3)/GT_p^2}{(4\pi^2 R_m^3)/GT_m^2} = \left(\frac{R_p}{R_m}\right)^3 \left(\frac{T_m}{T_p}\right)^2$$

as desired. (b) Inserting the given numerical values, we find

$$\frac{M_s}{M_p} = \left(\frac{1.50 \times 10^8}{3.85 \times 10^5}\right)^3 \left(\frac{27.3}{365.2}\right)^2 = \underline{3.30 \times 10^5}$$

- 6.36** (a) Find the orbital period of a satellite in a circular orbit of radius r about a spherical planet of mass M . (b) For a low-altitude orbit ($r \approx r_p$), show that for a given average planetary density (ρ) the orbital period is independent of the size of the planet.

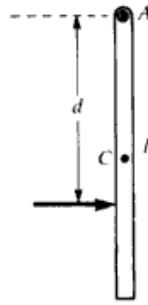

Fig. 12-11

$Pd = I_A\omega$, where $I_A = (ml^2)/3$ is the moment of inertia of the bar about the pivot. Since the distance from A to C is $l/2$, we also have $v_c = (\omega l)/2$. By combining the equations, we find $m[(\omega l)/2]d = [(ml^2)/3]\omega$, which implies that $d = 2l/3$. [Note the reciprocity with Prob. 12.36: a blow to the end (c.p.) causes rotation about the c.p. (end).]

- 12.40** Refer to Prob. 12.39. (a) What is the period of oscillation of the rod when it is suspended from A ? (b) What is the length of the simple pendulum having the same period? The length you obtain here should be the same as the distance you obtained in Prob. 12.39. The center of percussion relative to A is also called the *center of oscillation* relative to A .

▮ (a) The oscillation frequency is given by (see Prob. 12.38)

$$\nu_A = \frac{1}{2\pi} \sqrt{\frac{(l/2)g}{G_A^2}}$$

where $G_A^2 = I_A/m = l^2/3$. Therefore we obtain

$$T_A = 2\pi \sqrt{\frac{2l}{3g}}$$

(b) The period of a simple pendulum of length L is given by $2\pi\sqrt{L/g}$. Therefore the length of a simple pendulum with the oscillation period T_A is $L = 2l/3$, which is equal to the distance found in Prob. 12.39.

- 12.41** A ring of mass M and radius R is hung from a knife edge, so that the ring can swing in its own plane as a physical pendulum. Find the period T_1 of small oscillations.

▮ The ring is shown in Fig. 12-12, with the knife edge at point A . We must find the period T_1 of small oscillations in the plane of the paper. Taking the origin of a coordinate system at O , the equilibrium position of the ring's center, with the positive z axis emerging toward the viewer, the moment of inertia $I_{zO} = MR^2$. By the parallel-axis theorem, the moment of inertia about the knife edge is given by $I_{zA} = I_{zO} + MR^2 = 2MR^2$; hence, $G_A^2 = 2R^2$.

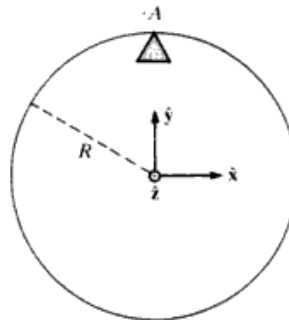

Fig. 12-12

Substituting this and $D = R$ in Eq. (1) of Prob. 12.38, we find

$$\nu_1 = \frac{1}{2\pi} \sqrt{\frac{g}{2R}} \quad \text{and} \quad T_1 = \frac{1}{\nu_1} = 2\pi \sqrt{\frac{2R}{g}}$$

- 12.42** Refer to Prob. 12.41. (a) Suppose that an identical ring is pivoted from an axis PP' lying in the ring plane

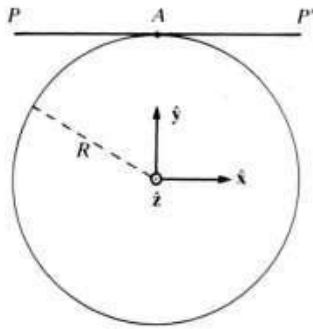

Fig. 12-13

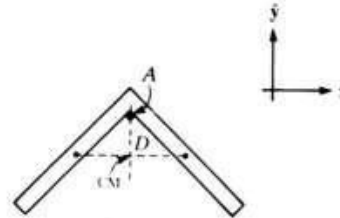

Fig. 12-14

and tangent to the circumference (Fig. 12-13). This ring can execute oscillations in and out of the plane. Find the period T_2 of those small oscillations. (b) Which oscillation has the longer period? How much longer?

▮ (a) Now the ring is pivoted about the axis PP' as shown at right. By the parallel-axis theorem, $I_{PP'} = I_{CO} + MR^2$. As shown in Prob. 11.41, $I_{CO} = (MR^2)/2$, so $I_{PP'} = (3MR^2)/2$. With $G_A^2 = 3R^2/2$ and $D = R$, (1) of Prob. 12.38 gives $T_2 = 1/\nu_2 = 2\pi\sqrt{3R/2g}$. (b) $T_1/T_2 = \sqrt{3} = 1.1547$. The period for oscillations in the plane is 15.5 percent longer than the period for oscillations about the axis PP' .

12.43 A uniform right-angle iron is hung over a thin nail so that the iron pivots freely at the bend (Fig. 12-14). Each arm of the iron has mass m and length l . Find the period T of small oscillations (in the plane of the iron).

▮ The center of mass of the system is located on the angle bisector, at a distance $D = (l\sqrt{2}/4)$ from the pivot A . The moment of inertia I about an axis through A and perpendicular to the xy plane is given by $(ml^2)/3 + (ml^2)/3 = (2ml^2)/3$. Therefore the square of the gyration radius is given by $G^2 = I/M = [(2ml^2)/3](2m) = l^2/3$. We can now apply (1) of Prob. 12.38:

$$T = \frac{1}{\nu} = 2\pi \sqrt{\frac{G_A^2}{Dg}} = 2\pi \sqrt{\frac{l^2/3}{[(l\sqrt{2})/4]g}} = 2\pi \sqrt{\frac{2\sqrt{2}l}{3g}}$$

12.44 Figure 12-15 represents a three-dimensional object (not necessarily of uniform density) whose center of mass is at point C . The axis ZCZ' passing through point C has been chosen at random orientation. The body had gyration radius $G_C(ZZ')$ about the axis ZCZ' ; the notation $G_C(ZZ')$ makes explicit the fact that the gyration radius for an axis through C depends on the particular choice (ZZ') of axis.

Suppose that a physical pendulum is constructed by pivoting the body about the axis PP' , which is parallel to ZCZ' at a distance D . Prove that the frequency ν of small oscillations about equilibrium is given by

$$\nu = \frac{1}{2\pi} \sqrt{\frac{Dg}{G_C^2(ZZ') + D^2}}$$

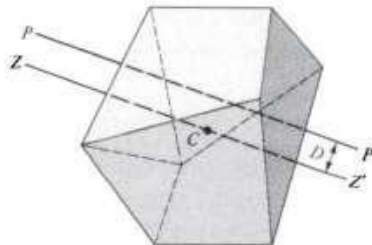

Fig. 12-15

▮ The desired result follows at once from (1) of Prob. 12.38. It is seen that the frequency of pendulum oscillations is the same for any choice of axis PP' on a cylinder of radius D centered on ZZ' .

12.45 Figure 12-16 depicts the *Kater pendulum*, used to measure the acceleration of gravity with high accuracy. It consists of a rigid rod on which a bob is mounted. The mass of the bob is sufficiently large so that the center of mass of the pendulum is fairly far from the middle of the rod. The bob is mounted on a slide; by moving the bob and then clamping it in position, the location of the center of mass of the pendulum can be adjusted. There are two very precisely honed knife-edges mounted on the rod. The pendulum can be swung from

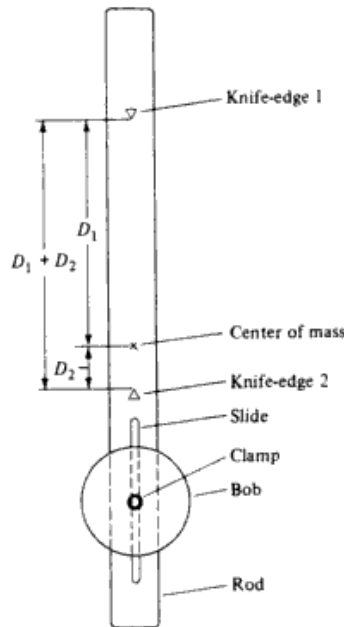

Fig. 12-16

knife-edge 1, and then reversed and swung from knife-edge 2. If G_0 is the gyration radius of the pendulum about an axis through its center of mass, what are the expressions for the periods of small oscillations about knife-edge 1 and knife-edge 2?

▮ From (1) of Prob. 12.38,

$$T_1 = \frac{1}{\nu_1} = 2\pi \sqrt{\frac{G_0^2 + D_1^2}{D_1 g}} \quad T_2 = \frac{1}{\nu_2} = 2\pi \sqrt{\frac{G_0^2 + D_2^2}{D_2 g}}$$

12.46 Refer to Prob. 12.45; can $T_1 = T_2$ for $D_1 \neq D_2$?

▮ Yes. Consider T for an arbitrary D and fixed G_0 , $T = 2\pi \sqrt{(G_0^2 + D^2)/(Dg)}$. If we plot T against D for D between 0 and ∞ , we note that $T \rightarrow \infty$ as $D \rightarrow 0$ and $T \rightarrow \infty$ as $D \rightarrow \infty$. Thus T has a minimum value, T_{\min} , for some $D = D_M$. Thus for any $T > T_{\min}$, there are two D values, one greater and one less than D_M .

12.3 ANGULAR MOMENTUM

12.47 Find the rotational energy and angular momentum due to the daily rotation of the earth about its axis. Data: $M_e = 6 \times 10^{24}$ kg, $R_e = 6.4 \times 10^6$ m, $\omega = 1/86\,400$ rev/s. Assume the earth to be a uniform sphere.

▮ $K_r = I\omega^2/2 = [(2Mr^2)/5][(2\pi/86\,400)^2]/2 = 2.6 \times 10^{29}$ J. Angular momentum = $I\omega = [(2Mr^2)/5](2\pi/86\,400) = 7.1 \times 10^{33}$ kg · m²/s. (The equivalent unit J · s is also used for angular momentum, especially in the atomic domain.)

12.48 Each of the wheels on a certain four-wheel vehicle has a mass of 30 kg and a radius of gyration of 30 cm. When the car is going forward and the wheels are turning at 5.0 rev/s, what is the rotational kinetic energy stored in the four wheels? What is the angular momentum of the vehicle about an axis parallel to the wheel axis and through the center of mass? Is the angular momentum vector directed toward the driver's right or left?

▮ $K_r = 4(I\omega^2/2) = 2(30)(0.30)^2(10\pi)^2 = 5300$ J. The angular momentum vector for each wheel is along the line described, so total $L = 4(I\omega) = 4(30)(0.09)(10\pi) = 340$ kg · m²/s. Note that ω must be in radians per second. The total L will be in the same direction as the angular velocity, that is, to the driver's left.

12.49 In a common physics lecture demonstrations, a lecturer sits on a stool that can rotate freely about a vertical axis on low-friction bearings. The lecturer holds with extended arms two dumbbells, each of mass m , and kicks the floor so as to achieve an initial angular speed ω_1 . The lecturer then pulls in the dumbbells, so that their distances from the rotation axis decrease from the initial value R_1 to the final value R_2 . Determine the

12.67 A student volunteer is sitting stationary on a piano stool with her feet off the floor. The stool can turn freely on its axle.

(a) The volunteer is handed a nonrotating bicycle wheel which has handles on the axle. Holding the axle vertically with one hand, she grasps the rim of the wheel with the other and spins the wheel clockwise (as seen from above). What happens to the volunteer as she does this? (b) She now grasps the ends of the vertical axle and turns the wheel until the axle is horizontal. What happens? (c) Next she gives the rotating wheel to the instructor, who turns the axle until it is vertical with the wheel rotating clockwise, as seen from above. The instructor now hands the wheel back to the volunteer. What happens? (d) The volunteer grasps the ends of the axle and turns the axle until it is horizontal. What happens now? (e) She continues turning the axle until it is vertical but with the wheel rotating counterclockwise as viewed from above. What is the result?

▮ Since the axle of the piano stool is frictionless, there are no vertical torques exerted on the stool-volunteer system, so the vertical component of angular momentum is conserved. (There are horizontal torques; these result from forces that the floor exerts on the base of the stool.)

(a) The initial angular momentum is zero, so the final angular momentum must also be zero. Therefore, the volunteer spins counterclockwise. (b) The angular momentum of the wheel is now horizontal. The volunteer's vertical component of angular momentum must now be zero, so she stops spinning. (c) When the wheel is handed back to the volunteer, the system of wheel and volunteer has a downward vertical angular momentum, all contributed by the wheel. The volunteer remains stationary. (d) Since the vertical component of the total angular momentum must not change, the volunteer must rotate clockwise. (e) The wheel's angular momentum is now upward. The volunteer must therefore have a downward vertical angular momentum to keep the total angular momentum pointing down. She must therefore spin clockwise. (Her spin rate is twice as fast as in part (d).)

12.68 A top consists of a uniform disk of mass m_0 and radius r_0 rigidly attached to an axial rod of negligible mass. The top is placed on a smooth table and set spinning about its axis of symmetry with angular speed ω_s . How much work must be done in setting the top spinning? Evaluate your result for $m_0 = 0.050$ kg, $r_0 = 2.0$ cm, and $\omega_s = 200\pi$ rad/s (or 6000 rotations per minute).

▮ The moment of inertia I_0 of the top is given by $I_0 = \frac{1}{2}m_0r_0^2$. The work required to set the top spinning with angular speed ω_s is equal to the spin kinetic energy $\frac{1}{2}I_0\omega_s^2$. For the given numerical values, we find $I_0 = (0.50)(0.050)(2.0 \times 10^{-2})^2 = 10^{-5}$ kg · m². The work required is $(0.5)(10^{-5})(200\pi)^2 = \underline{1.97$ J.

12.69 Refer to Prob. 12.68. The center of the disk is a distance d from the top's point of contact with the table. The top is observed to precess steadily about the vertical axis with angular speed ω_p . Assuming that $\omega_p \ll \omega_s$, write ω_p in terms of r_0 , d , ω_s , and g . Evaluate ω_p for $d = 3.0$ cm and $g = 9.80$ m/s², with the other quantities as given in Prob. 12.68. Is your result consistent with the assumption $\omega_p \ll \omega_s$?

▮ For $\omega_p \ll \omega_s$ the angular speed of steady precession is approximated by

$$\omega_p = \frac{gd}{G_0^2} \omega_s$$

where $G_0^2 = I_0/m_0 = \frac{1}{2}r_0^2$. With the numerical values given, we find

$$\omega_p = \frac{(9.80)(3.00 \times 10^{-2})}{(0.5)(2.00 \times 10^{-2})^2} \frac{1}{200\pi} = \underline{2.34 \text{ rad/s}}$$

The ratio of this angular speed to ω_s is $(\omega_p/\omega_s) = \underline{3.72 \times 10^{-3}}$. The assumption that $(\omega_p/\omega_s) \ll 1$ is fulfilled.

12.70 As shown in Fig. 12-24, a solid conical top of mass M , height h , and radius R is spinning about its symmetry axis OO' with spin angular speed ω_s . The axis OO' makes an angle α with the vertical.

We note that for such a system the center of mass of the top is located along OO' at a distance $3h/4$ from the vertex O , and the moment of inertia I about the axis OO' is given by $I = \frac{3}{10}MR^2$.

(a) Find the angular speed ω_p at which the top precesses about the vertical. (b) Consider a top for which $h = 10.0$ cm and $R = 3.0$ cm. The top is spinning at 5800 rotations per minute. Using $g = 9.80$ m/s², evaluate the precession angular speed ω_p .

▮ (a) Under the assumption that $\omega_p \ll \omega_s$, we can assume that

$$\omega_p \approx \frac{z_c g}{(I/M)\omega_s} = \frac{(3h/4)g}{(3R^2/10)\omega_s} = \frac{5hg}{2R^2\omega_s}$$

▮ For a force F and displacement s ,

$$k = \frac{F}{s} = \frac{mg}{s} = \frac{(1.8 \text{ kg})(9.8 \text{ m/s}^2)}{0.02} \quad k = 882 \text{ N/m}$$

$$F = ks = (882 \text{ N/m})(0.05 \text{ m}) \quad F = 44.1 \text{ N} \quad m = 4.50 \text{ kg}$$

13.24 A 10-kg mass is supported by a spring whose constant is 12 N/cm. Compute the elongation of the spring.

▮
$$F = mg \quad s = \frac{F}{k} = \frac{mg}{k} = \frac{(10 \text{ kg})(9.8 \text{ m/s}^2)}{12 \text{ N/cm}} \quad s = 8.17 \text{ cm}$$

Note that the mixed units for k need not be converted since mg in newtons cancels the newtons in k .

13.25 A load of 100 lb is applied to the lower end of a steel rod 3 ft long and 0.20 in in diameter. How much will the rod stretch? $Y = 3.3 \times 10^7 \text{ lb/in}^2$ for steel.

▮
$$Y = \frac{F/A}{\Delta L/L} \quad \text{or} \quad \Delta L = \frac{LF}{AY} = \frac{(3 \text{ ft})(100 \text{ lb})}{\pi(0.1 \text{ in}^2)(3.3 \times 10^7 \text{ lb/in}^2)} = 2.9 \times 10^{-4} \text{ ft} \quad \text{or} \quad \Delta L = 3.5 \times 10^{-3} \text{ in}$$

Note that the units of L and A need not agree as long as the units of A and Y agree, since (distance²) cancels between these two last quantities.

13.26 A wire whose cross section is 4 mm^2 is stretched by 0.1 mm by a certain weight. How far will a wire of the same material and length stretch if its cross-sectional area is 8 mm^2 and the same weight is attached?

▮ If the material and length are fixed as well as the stretching weight, then F , l , Y are fixed in the relation $\Delta l = (Fl)/(AY)$. Then

$$\Delta l \propto \frac{1}{A} \quad A \Delta l = \text{const} \quad \therefore A_1 \Delta l_1 = A_2 \Delta l_2 \quad \Delta l_2 = \frac{A_1}{A_2} \Delta l_1 = \frac{4 \text{ mm}^2}{8 \text{ mm}^2} 0.1 \text{ mm} \quad \Delta l_2 = 0.05 \text{ mm}$$

13.27 A steel wire is 4.0 m long and 2 mm in diameter. How much is it elongated by a suspended body of mass 20 kg? Young's modulus for steel is 196 000 MPa.

▮ Let ΔL be the elongation. Then, by Hooke's law,

$$\frac{F}{A} = Y \frac{\Delta L}{L}$$

where Y is Young's modulus. The elongation is

$$\Delta L = \frac{1}{Y} \frac{F}{A} L = \frac{mgL}{YA} = \frac{(20)(9.8)(4.0)}{(196 \times 10^9)\pi(0.001)^2} = 1.273 \times 10^{-3} \text{ m} = 1.273 \text{ mm}$$

13.28 A copper wire 2.0 m long and 2 mm in diameter is stretched 1 mm. What tension is needed? Young's modulus for copper is 117 600 MPa.

▮
$$\frac{F}{A} = Y \frac{\Delta L}{L} \quad F = Y \frac{\Delta L}{L} A = (117.6 \times 10^9) \frac{0.001}{2} \pi(0.001)^2 = 184.7 \text{ N}$$

13.29 A wire is stretched 1 mm by a force of 1 kN. (a) How far would a wire of the same material and length but of four times that diameter be stretched? (b) How much work is done in stretching each wire?

▮ (a) The elongation is inversely proportional to the cross-sectional area, and so $\Delta L = (1)(\frac{1}{4})^2 = \frac{1}{16} \text{ mm}$.
(b) The work done in stretching the wire in the two cases is $W = \bar{F}x$. Since the force varies linearly with distance,

$$\bar{F} = \frac{F_i + F_f}{2} \quad \text{so} \quad W_1 = \frac{1000 + 0}{2} (0.001) = 0.5 \text{ J} \quad W_2 = \frac{1}{16} W_1 = 0.0313 \text{ J}$$

13.30 Given a 2.0-m length of steel wire with 1.0-mm diameter, about how much will the wire stretch under a 5.0-kg load? $Y = 195 \text{ 000 MPa}$.

▮ Since tensile modulus is stress/strain, we have $\Delta L/L = (F/A)/Y = [5(9.8)]/[\pi(5 \times 10^{-4})^2(195 \times 10^9)] = 3.2 \times 10^{-4}$ and $\Delta L = 6.4 \times 10^{-4} \text{ m}$.

- 13.31** Approximately how large a force is required to stretch a 2.0-cm-diameter steel rod by 0.01 percent?
 $Y = 195\,000\text{ MPa}$.

| Solving Hooke's law for F , it is $F = AY(\Delta L/L) = \pi(0.01)^2(195 \times 10^9)(10^{-4}) = \underline{6100\text{ N}}$.

- 13.32** A platform is suspended by four wires at its corners. The wires are 3 m long and have a diameter of 2.0 mm. Young's modulus for the material of the wires is 180 000 MPa. How far will the platform drop (due to elongation of the wires) if a 50-kg load is placed at the center of the platform?

| $\Delta L = (LF)/(AY)$, where $L = 3\text{ m}$, $A = \pi(1.0 \times 10^{-3}\text{ m})^2 = 3.14 \times 10^{-6}\text{ m}^2$, and since each wire supports one-quarter of the load, $F = [(50\text{ kg})(9.8\text{ m/s}^2)]/4 = 123\text{ N}$.

$$\Delta L = \frac{(3\text{ m})(123\text{ N})}{(3.14 \times 10^{-6}\text{ m}^2)(1.8 \times 10^{11}\text{ N/m}^2)} = 65 \times 10^{-5}\text{ m} \quad \text{or} \quad \underline{0.65\text{ mm}}$$

- 13.33** What is the minimum diameter of a brass rod if it is to support a 400-N load without exceeding the elastic limit? Assume that the stress for the elastic limit is 379 MPa.

| To find the minimum diameter, and hence minimum cross-sectional area, we assume that the force $F = 400\text{ N}$ brings us to the elastic limit. Then from the stress, $F/A = 379 \times 10^6\text{ Pa}$, we get $A = (400\text{ N})/(379 \times 10^6\text{ Pa}) = 1.0554 \times 10^{-6}\text{ m}^2$. Then

$$A = \frac{\pi D^2}{4} \quad D^2 = \frac{4A}{\pi} = \frac{4(1.0554 \times 10^{-6}\text{ m}^2)}{\pi} = 1.344 \times 10^{-6}$$

and

$$D = \sqrt{1.344 \times 10^{-6}\text{ m}^2} = 1.16 \times 10^{-3}\text{ m} = \underline{1.16\text{ mm}}$$

- 13.34** A No. 18 copper wire has a diameter of 0.04 in and is originally 10 ft long. **(a)** What is the greatest load that can be supported by this wire without exceeding its elastic limit? **(b)** Compute the change in length of the wire under this load. **(c)** What is the maximum load that can be supported without breaking the wire? **(d)** What is the maximum elongation? (Assume that the elastic limit stress is 23 000 lb/in² and that the ultimate strength stress is 49 000 lb/in².)

| **(a)** $F/A = 23\,000\text{ lb/in}^2$, so $F_{\max} = (23\,000\text{ lb/in}^2)A$.

$$A = \frac{\pi D^2}{4} = \frac{\pi(0.04\text{ in})^2}{4} = 4\pi \times 10^{-4}\text{ in}^2 \quad F_{\max} = (23\,000)(4\pi \times 10^{-4}) = \underline{28.9\text{ lb}}$$

(b) $\Delta l = (F/A)(l/Y) = (23\,000\text{ lb/in})(10\text{ ft})/(17 \times 10^6\text{ lb/in}) = \underline{0.0135\text{ ft}}$

(c) $F'/A = (49\,000\text{ lb/in}^2)$; $F' = (49\,000\text{ lb/in}^2)(4\pi \times 10^{-4}\text{ in}^2) = \underline{61.6\text{ lb}}$

(d) $\Delta l' = (49\,000\text{ lb/in}^2)(10\text{ ft})/(17 \times 10^6\text{ lb/in}^2) = 0.0288\text{ ft} = \underline{0.346\text{ in}}$

- 13.35** A steel piano wire has an ultimate strength of about 35 000 lb/in². How large a load can a 0.5-in-diameter steel wire hold before breaking?

| $F = (35\,000\text{ lb/in}^2)A$ $A = \frac{\pi(0.05\text{ in})^2}{4} = 1.964 \times 10^{-3}\text{ in}^2$ $F = (35\,000\text{ lb/in}^2)(1.964 \times 10^{-3}\text{ in}^2) = \underline{68.7\text{ lb}}$

- 13.36^c** A wire of original length L and cross-sectional area A is stretched, within the elastic limit, by a stress τ . Show that the density of stored elastic energy in the stretched wire is $\tau^2/2Y$.

| Let the total deformation be ΔL , so that $\tau = Y(\Delta L/L)$, by Hooke's law. Again by Hooke's law, the stretching force at deformation x is given by $F(x) = [(AY)/L]x$. Hence the stored elastic energy is

$$W = \int_0^{\Delta L} F(x) dx = \frac{AY}{L} \int_0^{(L\tau)/Y} x dx = \frac{\tau^2}{2Y} AL$$

But, neglecting a tiny change, the constant volume of the wire is $V = AL$; hence

$$\frac{W}{V} = \frac{\tau^2}{2Y}$$

Note that the energy density is independent of the wire dimensions.

- 13.37** Determine the fractional change in volume as the pressure of the atmosphere (0.1 MPa) around a metal block is reduced to zero by placing the block in vacuum. The bulk modulus for the metal is 125 000 MPa.

$$\mathbf{I} \quad B = \frac{-\Delta p}{\Delta V/V} \quad \text{or} \quad \frac{\Delta V}{V} = -\frac{\Delta p}{B} = \frac{-(-0.1)}{125\,000} = 8 \times 10^{-7}$$

- 13.38** Compute the volume change of a solid copper cube, 40 mm on each edge, when subjected to a pressure of 20 MPa. The bulk modulus for copper is 125 000 MPa.

$$\mathbf{I} \quad \Delta V = \frac{-V\Delta p}{B} = \frac{-(40\text{ mm})^3(20\text{ MPa})}{125\,000\text{ MPa}} = -10\text{ mm}^3$$

Note that the units of V and Δp need not agree because $\Delta p/B$ is dimensionless.

- 13.39** The pressure in an explosion chamber is 345 MPa. What would be the percent change in volume of a piece of copper subjected to this pressure? The bulk modulus for copper is 138 GPa ($=138 \times 10^9$ Pa).

I The bulk modulus is defined as $B = -\Delta p/(\Delta V/V)$, where the minus sign is inserted because ΔV is negative when Δp is positive.

$$100 \left| \frac{\Delta V}{V} \right| = 100 \frac{\Delta p}{B} = 100 \frac{345 \times 10^6}{138 \times 10^9} = 0.25\%$$

- 13.40** The compressibility of water is 5×10^{-10} m²/N. Find the decrease in volume of 100 mL of water when subjected to a pressure of 15 MPa.

I We note that the compressibility, k , is simply the reciprocal of the bulk modulus. Then $\Delta V = -Vk \Delta p = -(100\text{ mL})(5 \times 10^{-10}\text{ m}^2/\text{N})(15 \times 10^6\text{ N/m}^2) = -0.75\text{ mL}$. The decrease is thus 0.75 mL.

- 13.41** How large a pressure must be applied to water if it is to be compressed by 0.1 percent? What is the ratio of this pressure to atmospheric pressure, 101 kPa? The bulk modulus of water is 2100 MPa.

I The volume strain $\Delta V/V_0 = 1.0 \times 10^{-3}$; set $B = p/(\Delta V/V_0)$ to find $p = (2.1 \times 10^9)(1.0 \times 10^{-3}) = 2100\text{ kPa}$. Dividing by the atmospheric pressure, the ratio is 21.

- 13.42** By what fraction will the volume of a steel bar increase as the air is evacuated from a chamber in which it rests? Standard atmospheric pressure = 0.101 MPa and B for steel is 160 000 MPa.

$$\mathbf{I} \quad \Delta V/V_0 = -\Delta P/B = 0.101/160\,000 = 6.3 \times 10^{-7}$$

- 13.43** What increase in pressure is required to decrease the volume of 200 L of water by 0.004 percent? Find ΔV . ($B = 2100$ MPa)

$$\mathbf{I} \quad \Delta V = 0.00004(200\text{ L}) = 0.008\text{ L} \quad \Delta p = B\left(-\frac{\Delta V}{V}\right) = (2100\text{ MPa})\left(\frac{0.008\text{ L}}{200\text{ L}}\right) = 0.084\text{ MPa} = \underline{84\text{ kPa}}$$

- 13.44** Compute the compressibility of glycerin if a pressure of 290 lb/in² causes a volume of 64 in³ to decrease by 3×10^{-3} in³.

I The compressibility is the reciprocal of the bulk modulus. Thus

$$k = -\frac{1}{\Delta p} \frac{\Delta V}{V_0} = \frac{3 \times 10^{-3}\text{ in}^3}{(290\text{ lb/in}^2)(64\text{ in}^3)} = \underline{1.62 \times 10^{-7}\text{ in}^2/\text{lb}}$$

- 13.45** Two parallel and opposite forces, each 4000 N, are applied tangentially to the upper and lower faces of a cubical metal block 25 cm on a side. Find the angle of shear and the displacement of the upper surface relative to the lower surface. The shear modulus for the metal is 80 GPa.

I We use the approximate form $S = F/(A\phi)$ (Prob. 13.20), with $S = 8 \times 10^{10}\text{ N/m}^2$, $F = 4000\text{ N}$, and $A = (0.25\text{ m})^2 = 6.25 \times 10^{-2}\text{ m}^2$. Solving for ϕ , we get

$$\phi = \frac{(4000\text{ N})}{(6.25 \times 10^{-2}\text{ m}^2)(8 \times 10^{10}\text{ N/m}^2)} = \underline{8.0 \times 10^{-7}\text{ rad}}$$

The displacement of the upper surface is given by $d = L\phi$, where L is an edge of the cube; $d = (8.0 \times 10^{-7})(25\text{ cm}) = \underline{2.0 \times 10^{-5}\text{ cm}}$.

- 13.46** The shear modulus for a metal is 50 000 MPa. Suppose that a shear force of 200 N is applied to the upper surface of a cube of this metal that is 3.0 cm on each edge. How far will the top surface be displaced?

▮ Shearing strain $= \Delta L/L = (F/A)/S = 200/[L^2(5 \times 10^{10})] = (4 \times 10^{-9})/L^2$; solve for ΔL with $L = 0.030$ m, $\Delta L = 1.33 \times 10^{-7}$ m = 0.133 μ m.

- 13.47** A block of gelatin is 60 mm by 60 mm by 20 mm when unstressed. A force of 0.245 N is applied tangentially to the upper surface, causing a 5-mm displacement relative to the lower surface (Fig. 13-2). Find (a) the shearing stress, (b) the shearing strain, and (c) the shear modulus.

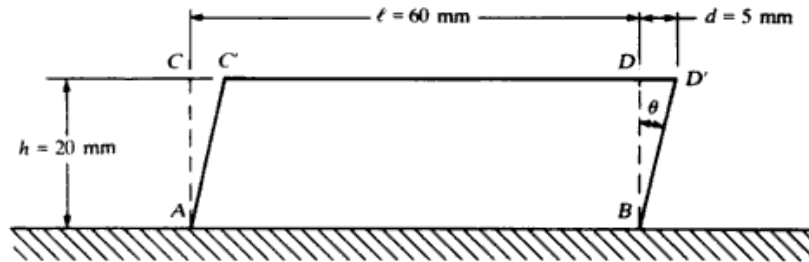

Fig. 13-2

- ▮ (a)
$$\text{stress} = \frac{F}{A} = \frac{0.245}{36 \times 10^{-4}} = \underline{68.1 \text{ Pa}}$$
- (b)
$$\text{strain} = \tan \theta = \frac{d}{h} = \frac{5}{20} = \underline{0.25}$$
- (c)
$$\text{shear modulus} = S = \frac{F/A}{\tan \theta} = \frac{68.4}{0.25} = \underline{272.4 \text{ N/m}^2}$$

- 13.48** Two sheets of aluminum on an aircraft wing are to be held together by aluminum rivets of cross-sectional area 0.25 in². The shearing stress on each rivet must not exceed one-tenth of the elastic limit for aluminum. How many rivets are needed if each rivet supports the same fraction of a total shearing force of 25 000 lb? Assume that the elastic limit stress is 19 000 lb/in².

▮ $F/A = \frac{1}{10}(19\,000 \text{ lb/in}^2) = 1900 \text{ lb/in}^2$ maximum stress allowed for each rivet. This means a shearing force of $F = (1900 \text{ lb/in}^2)(0.25 \text{ in}^2) = 475 \text{ lb/rivet}$. Number of rivets = $25\,000 \text{ lb}/(475 \text{ lb/rivet}) = 52.7$, or 53 rivets.

- 13.49** A 60-kg motor sits on four cylindrical rubber blocks. Each cylinder has a height of 3 cm and a cross-sectional area of 15 cm². The shear modulus for this rubber is 2 MPa. (a) If a sideways force of 300 N is applied to the motor, how far will it move sideways? (b) With what frequency will the motor vibrate back and forth sideways if disturbed?

▮ (a) We assume that the shear force is distributed evenly among the four cylinders. Then for a given cylinder $F = 75$ N.

$$\phi = \frac{F}{AS} = \frac{75 \text{ N}}{(15 \times 10^{-4} \text{ m}^2)(2 \times 10^6 \text{ N/m}^2)} = 2.5 \times 10^{-2} \text{ rad}$$

The displacement is then $d = L\phi = (3.0 \text{ cm})(2.5 \times 10^{-2} \text{ rad}) = \underline{0.075 \text{ cm}}$. (b) Since the shear force on each cylinder is proportional to ϕ , it is also proportional to the horizontal displacement d . $F = AS\phi = [(AS)/L]d$. Since there are four cylinders, the total external horizontal force, F_r , is given by $F_r = [(4AS)/L]d$. This force just balances the elastic restoring force, or effective “spring” force, of the system $F_s = -[(4AS)/L]d$. If the shear force is removed, the system oscillates with an effective force constant $k = (4AS)/L = 4.0 \times 10^5 \text{ N/m}$. Assuming that the masses of the cylinders are negligible, we have

$$f = \frac{1}{2\pi} \sqrt{\frac{k}{m}} = \frac{1}{2\pi} \sqrt{\frac{4.0 \times 10^5 \text{ N/m}}{60 \text{ kg}}} = \underline{13 \text{ Hz}}$$

- 13.50** The twisting of a cylindrical shaft (Fig. 13-3) through an angle θ is an example of a shearing strain. An

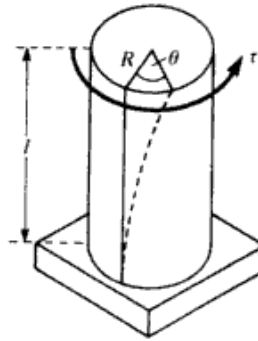

Fig. 13-3

analysis of the situation shows that the angle of twist (in radians) is given by

$$\theta = \frac{2\tau l}{\pi S R^4}$$

where τ = applied torque

l = length of cylinder

R = radius of cylinder

S = shear modulus for material

If a torque of 100 lb · ft is applied to the end of a cylindrical steel shaft 10 ft long and 2 in in diameter, through how many degrees will the shaft twist? Assume that $S = 12 \times 10^6$ lb/in².

▮ We are given $S = 12 \times 10^6$ lb/in², $R = 1$ in, $\tau = 100$ lb · ft = 1200 lb · in, $l = 10$ ft = 120 in. Using the given formula we find that

$$\theta = \frac{2\tau l}{\pi S R^4} = \frac{2(1200 \text{ lb} \cdot \text{in})(120 \text{ in})}{\pi(12 \times 10^6 \text{ lb}/\text{in}^2)(1 \text{ in})^4} = 7.64 \times 10^{-3} \text{ rad} = \underline{0.437^\circ}$$

- 13.51** An engine delivers 140 hp at 800 rpm to an 8-ft solid-iron drive shaft 2 in in diameter. Find the angle of twist in the drive shaft. Assume that $S = 10 \times 10^6$ lb/in².

▮ First calculate the torque, then apply Prob. 13.50.

$$P = 140 \text{ hp} \left(550 \frac{\text{ft} \cdot \text{lb}/\text{s}}{\text{hp}} \right) = 7.7 \times 10^4 \text{ ft} \cdot \text{lb}/\text{s}; \quad \omega = 2\pi f = 2\pi(800 \text{ rad}/\text{s})(1 \text{ min}/60 \text{ s}) = 83.78 \text{ rad}/\text{s},$$

$$P = \tau\omega, \quad \text{so} \quad \tau = \frac{P}{\omega} = \frac{7.7 \times 10^4 \text{ ft} \cdot \text{lb}/\text{s}}{83.78 \text{ rad}/\text{s}} = 919 \text{ lb} \cdot \text{ft} = 11\,000 \text{ lb} \cdot \text{in}.$$

Finally

$$\theta = \frac{2\tau l}{\pi S R^4} = \frac{2(11\,000 \text{ lb} \cdot \text{in})(8 \text{ ft})(12 \text{ in}/\text{ft})}{\pi(10 \times 10^6 \text{ lb}/\text{in}^2)(1 \text{ in})^4} = 0.0674 \text{ rad} = \underline{3.86^\circ}$$

CHAPTER 14

Simple Harmonic Motion

14.1 OSCILLATIONS OF A MASS ON A SPRING

14.1 A spring makes 12 vibrations in 40 s. Find the period and frequency of the vibration.

$$T = \frac{\text{elapsed time}}{\text{vibrations made}} = \frac{40 \text{ s}}{12} = \underline{3.3 \text{ s}} \quad f = \frac{\text{vibrations made}}{\text{elapsed time}} = \frac{12}{40 \text{ s}} = \underline{0.30 \text{ Hz}}$$

14.2 A 50-g mass hangs at the end of a Hookean spring. When 20 g more are added to the end of the spring, it stretches 7.0 cm more. (a) Find the spring constant. (b) If the 20 g are now removed, what will be the period of the motion?

▮ (a) Since the spring is linear,

$$k = \frac{\Delta F}{\Delta x} = \frac{(0.020 \text{ kg})(9.8 \text{ m/s}^2)}{0.07 \text{ m}} = \underline{2.8 \text{ N/m}}$$

$$(b) \quad T = 2\pi \sqrt{\frac{m}{k}} = 2\pi \sqrt{\frac{0.050 \text{ kg}}{2.8 \text{ N/m}}} = \underline{0.84 \text{ s}}$$

14.3 A spring is stretched 4 cm when a mass of 50 g is hung on it. If a total of 150 g is hung on the spring and the mass is started in a vertical oscillation, what will the period of the oscillation be?

▮ First find the spring constant k :

$$k = \frac{(50 \text{ g})(980 \text{ cm/s}^2)}{4 \text{ cm}} = 12\,250 \text{ dyn/cm}$$

To find the period use

$$T = 2\pi \sqrt{\frac{m}{k}} = 2\pi \sqrt{\frac{150}{12\,250}} = 2\pi(0.1107) = \underline{0.695 \text{ s}}$$

14.4 A body of weight 27 N hangs on a long spring of such stiffness that an extra force of 9 N stretches the spring 0.05 m. If the body is pulled downward and released, what is its period?

▮ The spring constant is $k = 9/0.05 = 180 \text{ N/m}$, and so

$$T = 2\pi \sqrt{\frac{m}{k}} = 2\pi \sqrt{\frac{27/9.8}{180}} = \underline{0.78 \text{ s}}$$

14.5 A 3-lb weight hangs at the end of a spring which has $k = 25 \text{ lb/ft}$. If the weight is displaced slightly and released, with what frequency will it vibrate?

▮ Using $m = 3 \text{ lb}/(32.2 \text{ ft/s}^2) = 0.093 \text{ slug}$ gives

$$f = \frac{1}{2\pi} \sqrt{\frac{k}{m}} = \frac{1}{2\pi} \sqrt{\frac{25 \text{ lb/ft}}{0.093 \text{ slug}}} = \underline{2.61 \text{ Hz}}$$

14.6 A mass m suspended from a spring of constant k has a period T . If a mass M is added, the period becomes $3T$. Find M in terms of m .

▮ The period varies as the square root of the mass. Thus the mass must increase ninefold, making $M = \underline{8m}$.

14.7 A 0.5-kg body performs simple harmonic motion with a frequency of 2 Hz and an amplitude of 8 mm. Find the maximum velocity of the body, its maximum acceleration, and the maximum restoring force to which the body is subjected.

▮ We are given frequency ν and amplitude R : $\nu = 2 \text{ Hz}$; $\omega = 2\pi\nu = 4\pi \text{ rad/s}$; $R = 0.008 \text{ m}$. Then we have

15.15 Find the ratio of a systolic blood pressure of 120 (in mmHg) to atmospheric pressure. Standard atmospheric pressure is 1.01×10^5 Pa.

▮ Pressure due to 0.120 m of mercury = $\rho gh = (13\,600)(9.8)(0.120) = 0.16 \times 10^5$ Pa. Ratio = $0.16/1.01 = 0.16$.

15.16 If the blood vessels in a human being acted as simple pipes (which they do not), what would be the difference in blood pressure between the blood in a 1.80-m-tall man's feet and in his head when he is standing? Assume the specific gravity of blood to be 1.06.

▮ $\Delta p = \rho gh = 1060(9.8)(1.8) = 18.7$ kPa.

15.17 What is the pressure due to the water 1 mi beneath the ocean's surface if we assume the mean density of seawater to be 1025 kg/m^3 ? If its compressibility is the same as that of pure water (bulk modulus = 2000 MPa), by what percent has the density changed in going from the surface to this depth (1 mi = 1609 m)?

▮ $\Delta p = \rho gh = 1025(9.8)(1609) = 16.2$ MPa. By definition of the bulk modulus, $B = -\Delta p/(\Delta V/V)$. But, for a fixed mass m ,

$$0 = \Delta m = \rho \Delta V + V \Delta \rho \quad \text{whence} \quad \frac{\Delta V}{V} = -\frac{\Delta \rho}{\rho}$$

Therefore $B = \Delta p/(\Delta \rho/\rho)$, or

$$\frac{\Delta \rho}{\rho} = \frac{\Delta p}{B} = \frac{16.2}{2000} = 0.0081 = 0.81\%$$

15.18 A cylindrical tank 3 ft in diameter and 4 ft high is filled with water whose weight density is 62.5 lb/ft^3 . Find the gauge pressure at the bottom of the tank.

▮ Use the equation for pressure at a depth y in a liquid. Ignore atmospheric pressure. $p_L = d_w y = 62.5 \text{ lb/ft}^3 \times 4 \text{ ft} = 250 \text{ lb/ft}^2$.

15.19 A tank contains a pool of mercury 0.30 m deep, covered with a layer of water that is 1.2 m deep. The density of water is $1.0 \times 10^3 \text{ kg/m}^3$ and that of mercury is $13.6 \times 10^3 \text{ kg/m}^3$. Find the pressure exerted by the double layer of liquids at the bottom of the tank. Ignore the pressure of the atmosphere.

▮ First find the pressure at the top of the mercury pool. For a point below the surface of the mercury this may be regarded as a source of external pressure p_{ext} . Thus

$$p_{ext} = \rho_{water} g h_{water} = (1.0 \times 10^3 \text{ kg/m}^3)(9.8 \text{ m/s}^2)(1.2 \text{ m}) = 12 \text{ kPa}$$

The pressure p_{int} exerted by the mercury column itself is found in the same manner:

$$p_{int} = \rho_{merc} g h_{merc} = (13.6 \times 10^3 \text{ kg/m}^3)(9.8 \text{ m/s}^2)(0.30 \text{ m}) = 40 \text{ kPa}$$

The total pressure at the bottom is thus 52 kPa.

15.20 How high does a mercury barometer stand on a day when atmospheric pressure is 98.6 kPa?

▮ $h = \frac{p_{atm}}{\rho_{Hg} g} = \frac{98.6 \times 10^3 \text{ N/m}^2}{(13.6 \times 10^3 \text{ kg/m}^3)(9.8 \text{ m/s}^2)} = 740 \text{ mm}$

15.21 Two liquids which do not react chemically are placed in a bent tube, as shown in Fig. 15-3. Show that the heights of the liquids above their surface of separation are inversely proportional to their densities.

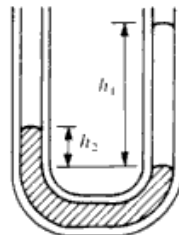

Fig. 15-3

▮ The pressure at the interface must be the same, calculated via either tube. Since both tubes are open to the atmosphere, we must have $\rho_1 g h_1 = \rho_2 g h_2$, or $h_1/h_2 = \rho_2/\rho_1$.

15.22 Assume that the two liquids in the U-shaped tube of Fig. 15-3 are water and oil. Compute the density of the oil if the water stands 19 cm above the interface and the oil stands 24 cm above the interface.

▮ We apply the result of Prob. 15.21:

$$\rho_{oil} = \left(\frac{h_w}{h_{oil}}\right)\rho_w = \frac{19 \text{ cm}}{24 \text{ cm}}(1000 \text{ kg/m}^3) = \underline{792 \text{ kg/m}^3}$$

15.23 A uniform glass tube is bent into a U shape such as that shown in Fig. 15-4. Water is poured into the tube until it stands 10 cm high in each tube. Benzene (sp gr = 0.879) is then added slowly to the tube on the left until the water rises 4 cm higher on the right. What length is the column of benzene when the situation is reached? (Water and benzene do not mix.)

▮ An 8-cm column of water balances the benzene column; so by Prob. 15.21,

$$h_b = \frac{h_w}{\rho_b/\rho_w} = \frac{8 \text{ cm}}{0.879} = \underline{9.1 \text{ cm}}$$

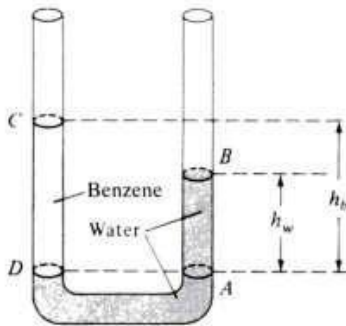

Fig. 15-4

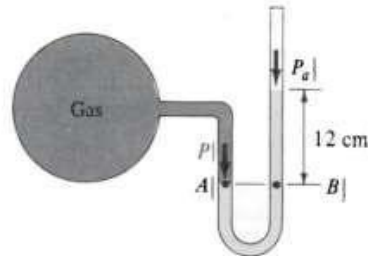

Fig. 15-5

15.24 The manometer shown in Fig. 15-5 uses mercury as its fluid. If atmospheric pressure is 100 kPa, what is the pressure of the gas in the container shown on the left?

▮ At points A and B pressures must be equal since the fluid is not moving. Therefore $P = P_a + \rho gh = 100 \text{ kPa} + [(13.6)(9.8)(0.12)] \text{ kPa} = \underline{116 \text{ kPa}}$.

15.25 A mercury barometer stands at 762 mm. A gas bubble, whose volume is 33 cm³ when it is at the bottom of a lake 45.7 m deep, rises to the surface. What is its volume at the surface of the lake?

▮ In terms of the weight density, ρg , of water,

$$p_{\text{bottom}} = \rho g y + p_{\text{atm}} = \rho g y + \rho \left(\frac{\rho_{Hg}}{\rho}\right) g h_{Hg} = \rho g [45.7 + (13.6)(0.762)] = 45.7 \rho g + 10.4 \rho g = 56.1 \rho g$$

For the bubble, *Boyle's law* states that $pV = \text{constant}$, assuming that the temperature stays fixed. Then,

$$V_{\text{surface}} = \frac{p_{\text{bottom}}}{p_{\text{surface}}} V_{\text{bottom}} = \frac{56.1 \rho g}{10.4 \rho g} \times 33 = \underline{178 \text{ cm}^3}$$

15.26 A small uniform tube is bent into a circle of radius r whose plane is vertical. Equal volumes of two fluids whose densities are ρ and σ ($\rho > \sigma$) fill half the circle (see Fig. 15-6). Find the angle that the radius passing through the interface makes with the vertical.

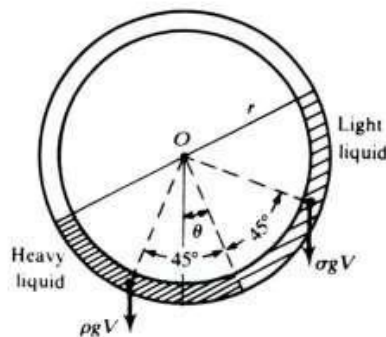

Fig. 15-6

▮ Of the external forces acting on the two fluid segments only the two weights, ρgV and σgV , have torques about the center O ; the forces exerted by the container are purely radial. Thus, for equilibrium,

$$0 = \rho gVr \sin(45^\circ - \theta) - \sigma gVr \sin(45^\circ + \theta)$$

$$0 = \rho(\sin 45^\circ \cos \theta - \cos 45^\circ \sin \theta) - \sigma(\sin 45^\circ \cos \theta + \cos 45^\circ \sin \theta)$$

$$0 = \rho(1 - \tan \theta) - \sigma(1 + \tan \theta) \quad \tan \theta = \frac{\rho - \sigma}{\rho + \sigma}$$

15.27 Rework Prob. 15.26 by requiring that the fluid pressures be equal at the interface.

▮ The pressure at the interface must be the same for the heavy and light liquids to have equilibrium. Referring to Fig. 15-6, we calculate the pressure at the interface due to the heavy liquid and set it equal to the pressure due to the light liquid. (The added contribution of the gas in the rest of the tube is the same for both liquids and can be ignored.) Then $\rho gh_1 = \sigma gh_2$, where h_1 and h_2 are the heights of the respective liquids above the interface. We have, from Fig. 15-6,

$$h_1 = r \cos \theta - r \cos(90^\circ - \theta) = r(\cos \theta - \sin \theta) \quad h_2 = r \cos \theta + r \sin \theta = r(\cos \theta + \sin \theta)$$

Substituting into the pressure equation and canceling g and r for both sides, we have $\rho(\cos \theta - \sin \theta) = \sigma(\cos \theta + \sin \theta)$, or dividing by $\cos \theta$, $\rho(1 - \tan \theta) = \sigma(1 + \tan \theta)$. Solving for $\tan \theta$, we get $\tan \theta = (\rho - \sigma)/(\rho + \sigma)$.

15.28^c Water stands at a depth h behind the vertical face of a dam, Fig. 15-7(a). It exerts a resultant horizontal force on the dam, tending to slide it along its foundation, and a torque, tending to overturn the dam about the point O . Find (a) the horizontal force, (b) the torque about O , and (c) the height at which the resultant force would have to act to produce the same torque

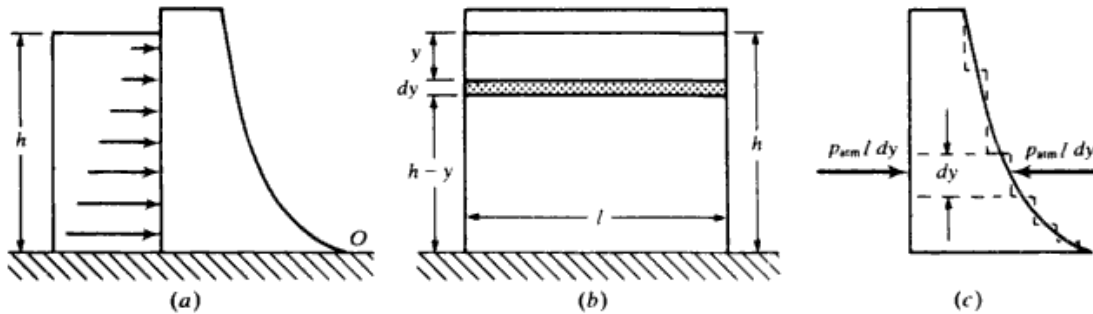

Fig. 15-7

▮ (a) Figure 15-7(b) is a view of the face of the dam from upstream. The pressure at depth y is $p = \rho gy$. We may neglect the atmospheric pressure, since it acts on the other side of the dam also. [The construction shown in Fig. 15-7(c) may be used to justify the neglect of atmospheric pressure.] The force against the shaded strip is $dF = p dA = \rho gyl dy$. The total force is

$$F = \rho gl \int_0^h y dy = \frac{\rho glh^2}{2}$$

(b) The torque of the force dF about an axis through O is, in magnitude, $d\tau = (h - y) dF = \rho gyl(h - y) dy$. The total torque about O is

$$\tau = \rho gl \int_0^h y(h - y) dy = \frac{\rho glh^3}{6}$$

(c) If H is the height above O at which the total force F would have to act to produce this torque,

$$HF = \tau \quad \text{or} \quad H = \frac{\tau}{F} = \frac{\rho glh^3/6}{\rho glh^2/2} = \frac{h}{3}$$

15.29^c A conical cup, $r = (b - z) \tan \alpha$, rests open-end-down on a smooth flat surface, as shown in Fig. 15-8. The cup is to be filled to a height h with liquid of density ρ . What will be the lifting force on the cup?

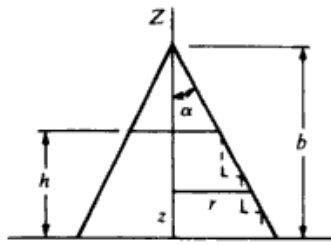

Fig. 15-8

Imagine that the inside surface of the cup consists of an infinite number of infinitesimal ring-shaped steps (Fig. 15-8). The pressure $p(z)$ acting on the vertical face of a step does not contribute to the lifting force, since it acts horizontally. Thus, the infinitesimal lifting force is only the pressure force on the horizontal face of the step:

$$dF_z = p(z) dA = \rho g(h - z)(2\pi r dr) = \rho g(h - z)[2\pi(b - z) \tan \alpha](-dz \tan \alpha)$$

Integrating to obtain the total lifting force, we get

$$F_z = -2\pi\rho g \tan^2 \alpha \int_h^0 (h - z)(b - z) dz = \pi\rho g \left(bh^2 - \frac{h^3}{3} \right) \tan^2 \alpha$$

15.30^c Redo Prob. 15.29 using the weight of the fluid and the force it exerts on the flat surface.

The total force exerted by the pressure of a static fluid on its container is equal to the fluid's weight. Hence, for this problem, $F_b - F_z = w$, where F_b is the downward force on the plane surface; F_z is the lifting force on the cup (by symmetry, the horizontal pressure forces on the cup cancel); and w is the weight of the liquid. Now,

$$F_b = p(0)A = \rho gh(\pi b^2 \tan^2 \alpha)$$

and

$$w = \rho gV = \rho g \int_0^h \pi r^2 dz = \rho g\pi \tan^2 \alpha \int_0^h (b - z)^2 dz = (\rho g\pi \tan^2 \alpha) \left(b^2h - bh^2 + \frac{h^3}{3} \right)$$

Consequently,

$$F_z = F_b - w = (\rho g\pi \tan^2 \alpha) \left(bh^2 - \frac{h^3}{3} \right)$$

as before.

15.31 As shown in Fig. 15-9, a weighted piston holds compressed gas in a tank. The piston and its weights have a mass of 20 kg. The cross-sectional area of the piston is 8 cm². What is the total pressure of the gas in the tank? What would an ordinary pressure gauge on the tank read?

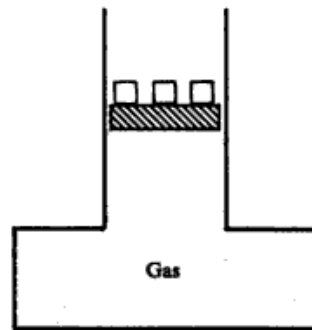

Fig. 15-9

The total pressure in the tank will be the pressure of the atmosphere (about 1.0×10^5 Pa) plus the pressure due to the piston and weights.

$$p = 1.0 \times 10^5 \text{ N/m}^2 + \frac{(20)(9.8) \text{ N}}{8 \times 10^{-4} \text{ m}^2} = 1.0 \times 10^5 \text{ N/m}^2 + 2.45 \times 10^5 \text{ N/m}^2 = 3.45 \times 10^5 \text{ N/m}^2 = \underline{345 \text{ kPa}}$$

A pressure gauge on the tank would read the difference between the pressure inside and outside the tank: gauge reading = $2.45 \times 10^5 \text{ N/m}^2 = \underline{245 \text{ kPa}}$. It reads the pressure due to the piston and weights.

15.32 Refer to Prob. 15.31; assume that the area of the tank bottom is 20 cm². (a) Find the total force on the bottom of the tank and compare it with the weight of the piston plus the force of atmosphere on the piston. (The weight of the compressed air is negligible.) (b) How do you explain the result?

15.2 PASCAL'S AND ARCHIMEDES' PRINCIPLES; SURFACE TENSION

15.39 A hydraulic lift in a service station has a large piston 30 cm in diameter and a small piston 2 cm in diameter. **(a)** What force is required on the small piston to lift a load of 1500 kg? **(b)** What is the pressure increase due to the force in the confined liquid?

| **(a)** Pascal's principle says that the pressure change is uniformly transmitted throughout the oil, so $\Delta p = F_1/A_1 = F_2/A_2$, where F_1 and F_2 are the forces on the small and on the large pistons, respectively, and A_1 and A_2 are the respective areas. Thus,

$$\frac{F_1}{\pi(2^2/4)} = \frac{1500 \times 9.8}{\pi(30^2/4)}$$

Multiplying both sides by $\pi/4$ and solving for F_1 , we obtain

$$F_1 = \frac{(1500)(9.8)(2^2)}{30^2} = \underline{65 \text{ N}}$$

(b)
$$\Delta p = \frac{F_1}{A_1} = \frac{65}{\pi(2^2/4)} = 21 \text{ N/cm}^2 = 210 \text{ kPa}$$

15.40 A hydraulic lift is to be used to lift a truck weighing 5000 lb. If the diameter of the large piston of the lift is 1 ft, what gauge pressure in lb/in² must be applied to the oil?

| The gauge pressure in the oil acts, by Pascal's principle, on the bottom of the large piston to produce the force that lifts the load.

$$\Delta p = \frac{F}{A} = \frac{5000}{\pi r^2} = \frac{5000}{\pi(0.5^2)} = 6370 \text{ lb/ft}^2 = \frac{6370}{144} = \underline{44.2 \text{ lb/in}^2}$$

15.41 In a hydraulic press the large piston has cross-sectional area $A_1 = 200 \text{ cm}^2$ and the small piston has cross-sectional area $A_2 = 5 \text{ cm}^2$. If a force of 250 N is applied to the small piston, what is the force F_1 on the large piston?

| By Pascal's principle,

$$\text{pressure under large piston} = \text{pressure under small piston} \quad \frac{F_1}{A_1} = \frac{F_2}{A_2}$$

$$F_1 = \frac{A_1}{A_2} F_2 = \frac{200}{5} (250 \text{ N}) = \underline{10 \text{ kN}}$$

15.42 For the system shown in Fig. 15-14, the cylinder on the left, at L , has a mass of 600 kg and a cross-sectional area of 800 cm². The piston on the right, at S , has cross-sectional area 25 cm² and negligible weight. If the apparatus is filled with oil ($\rho = 0.78 \text{ g/cm}^3$), what is the force F required to hold the system in equilibrium as shown?

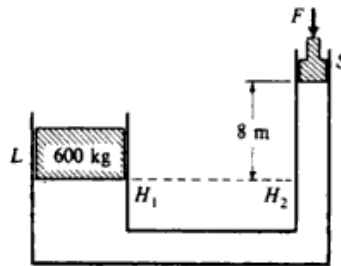

Fig. 15-14

| The pressures at points H_1 and H_2 are equal since they are at the same level in a single connected fluid. Therefore,

$$\begin{aligned} \text{pressure at } H_1 &= \text{pressure at } H_2 \\ \left(\begin{array}{l} \text{pressure due to} \\ \text{left piston} \end{array} \right) &= \left(\begin{array}{l} \text{pressure due to } F \\ \text{and right piston} \end{array} \right) + \left(\begin{array}{l} \text{pressure due to 8 m of oil} \end{array} \right) \\ \frac{(600)(9.8) \text{ N}}{0.08 \text{ m}^2} &= \frac{F}{25 \times 10^{-4} \text{ m}^2} + (8 \text{ m})(780 \text{ kg/m}^3)(9.8 \text{ m/s}^2) \end{aligned}$$

Solving for F gives it to be 31 N.

- 15.43** A block of wood weighing 71.2 N and of specific gravity 0.75 is tied by a string to the bottom of a tank of water in order to have the block totally immersed. What is the tension in the string?

| The block is in equilibrium under the action of three forces—the weight $w = 71.2$ N, the tension T , and the buoyant force B , with $B = w + T$. We can determine B since $B = \rho_L g V_B$, where ρ_L is the density of water and V_B is the volume of the totally immersed block. $w = \rho_B g V_B$, where ρ_B is the density of the block. Then $w/B = \rho_B/\rho_L = (\text{sp gr})_B = 0.75$, so $B = w/0.75 = 94.9$ N. Finally, from our equilibrium equation, 94.9 N = 71.2 N + T , or $T = \underline{23.7}$ N.

- 15.44** A metal ball weighs 0.096 N. When suspended in water it has an apparent weight of 0.071 N. Find the density of the metal.

| The desired density is given by $\rho = m/V$. But since the volume V of the ball is also the volume of displaced water, the buoyant force is given by $B = \rho_{\text{water}} g V$. Thus,

$$\rho = \frac{(mg)\rho_{\text{water}}}{B} = \frac{(0.096 \text{ N})(1 \times 10^3 \text{ kg/m}^3)}{(0.096 - 0.071) \text{ N}} = 3840 \text{ kg/m}^3$$

- 15.45** A block of material has a density ρ_1 and floats three-fourths submerged in a liquid of unknown density. Show that the density ρ_2 of the unknown liquid is given by $\rho_2 = \frac{4}{3}\rho_1$.

| By Archimedes' principle, $\rho_1 V g = \rho_2 (3V/4)g$, which gives $\rho_2 = \frac{4}{3}\rho_1$.

- 15.46** The density of ice is 917 kg/m^3 , and the approximate density of the seawater in which an iceberg floats is 1025 kg/m^3 . What fraction of the iceberg is beneath the water surface?

| By Prob. 15.45, fraction submerged = $\rho_1/\rho_2 = \frac{917}{1025} = \underline{0.89}$.

- 15.47** A block of wood has a mass of 25 g. When a 5-g metal piece with a volume of 2 cm^3 is attached to the bottom of the block, the wood barely floats in water. What is the volume V of the wood?

| The effective density of the system is $30/(V + 2) \text{ g/cm}^3$; hence, by Probs. 15.45 and 15.46,

$$1 = \text{fraction submerged} = \frac{30/(V + 2)}{1}$$

Solving, $V = \underline{28 \text{ cm}^3}$.

- 15.48** A piece of wood weighs in mass units 10.0 g in air. When a heavy piece of metal is suspended below it, the metal being submerged in water, the “weight” of wood in air plus metal in water is 14.00 g. The “weight” when both wood and metal are submerged in water is 2.00 g. Find the volume and the density of the wood.

| Since in both cases the metal is submerged, the difference in weight is only the buoyant force on the wood, or $(12.00 \times 10^{-3})(9.8)$ N. Therefore, the volume of the wood can be found by equating the weight of displaced water, $1000(9.8)V$, to this. Then $V = \underline{12 \times 10^{-6} \text{ m}^3}$. Its mass is $10 \times 10^{-3} \text{ kg}$ and so its density is $(10 \times 10^{-3})/(12 \times 10^{-6}) = \underline{830 \text{ kg/m}^3}$.

- 15.49** What is the minimum volume of a block of wood (density = 850 kg/m^3) if it is to hold a 50-kg woman entirely above the water when she stands on it?

| The woman's weight plus the block's weight must be equal to the buoyant force on the just barely submerged block, $50g + 850Vg = 1000Vg$, which leads to $V = \underline{0.33 \text{ m}^3}$.

- 15.50** A man whose weight is 667 N and whose density is 980 kg/m^3 can just float in water with his head above the surface with the help of a life jacket which is wholly immersed. Assuming that the volume of his head is $\frac{1}{13}$ of his whole volume and that the specific gravity of the life jacket is 0.25, find the volume of the life jacket.

| The man's volume is

$$V = \frac{w}{\rho g} = \frac{667}{(980)(9.8)} = 0.07 \text{ m}^3$$

Equating the buoyant force to the weight of the man plus the weight of the life jacket,

$$\rho_{\text{water}} g \left[\frac{13}{13} V + V_{\text{lj}} \right] = 667 + (0.25 \rho_{\text{water}}) g V_{\text{lj}}$$

Solving,

$$V_{ij} = \frac{(667/\rho_{\text{water}}) - (14/15)gV}{0.75g} = \frac{0.667 - (14/15)(9.8)(0.07)}{(0.75)(9.8)} = 0.004 \text{ m}^3 \quad \text{or} \quad \underline{4 \text{ L}}$$

- 15.51** An irregular piece of metal “weighs” 10.00 g in air and 8.00 g when submerged in water. **(a)** Find the volume of the metal and its density. **(b)** If the same piece of metal weighs 8.50 g when immersed in a particular oil, what is the density of the oil?

| Buoyant force = $(2 \times 10^{-3})g$ N, with $g = 9.8 \text{ m/s}^2$. This equals the weight of the displaced water, $\rho_w Vg$. Equating and using $\rho_w = 1000 \text{ kg/m}^3$ gives $V = 2 \times 10^{-6} \text{ m}^3$. The density = mass/ $V = (10 \times 10^{-3})/(2 \times 10^{-6}) = 5000 \text{ kg/m}^3$. The buoyant force in oil is $(1.50 \times 10^{-3})g$ N. The weight of the displaced oil is $\rho_o(2 \times 10^{-6})g$, from which $\rho_o = 750 \text{ kg/m}^3$.

- 15.52** A beaker partly filled with water has a total mass of 20.00 g. If a piece of wood having a density of 0.800 g/cm^3 and volume 2.0 cm^3 is floated on the water in the beaker, how much will the beaker “weigh” (in grams)?

| The scale must support both the original 20 g and the $(0.80 \text{ g/cm}^3)(2 \text{ cm}^3) = 1.60\text{-g}$ block, so the “weight” = 21.6 g.

- 15.53** A beaker when partly filled with water has total mass 20.00 g. If a piece of metal with density 3.00 g/cm^3 and volume 1.00 cm^3 is suspended by a thin string so that it is submerged in the water but does not rest on the bottom of the beaker, how much does the beaker then appear to weigh if it is resting on a scale?

| The tension in the thread is equal to the weight of the metal less the buoyant force. The buoyant force will be $(1 \times 10^{-6} \text{ m}^3)(1000 \text{ kg/m}^3)g = 10^{-3}g$ N, where $g = 9.8 \text{ m/s}^2$. The weight of the metal is $3 \times 10^{-3}g$ N. Therefore, the thread exerts an upward force of $2 \times 10^{-3}g$ N. Hence the scale supports the total weight less the tension in the thread. Therefore, the apparent weight read by a scale will be $(23 - 2) \text{ g}$, or 0.206 N .

Equivalently we can get the result by noting that if the water exerts an upward buoyant force of $10^{-3}g = 9.8 \times 10^{-3} \text{ N}$ on the metal, by Newton’s third law the metal exerts a like force downward on the water. Thus the scale balances the weight, 0.196 N , plus the downward force of the metal, 0.0098 N , for a total of 0.206 N .

- 15.54** A solid cube of material is 0.75 cm on each edge. It floats in oil of density 800 kg/m^3 with one-third of the block out of the oil. **(a)** What is the buoyant force on the cube? **(b)** What is the density of the material of the cube?

| (a) The block is in equilibrium so $\rho_B V_{Bg} = BF = \rho_o(2V_B/3)g$. Since $V_B = 4.22 \times 10^{-7} \text{ m}^3$ and $\rho_o = 800 \text{ kg/m}^3$, $BF = 2.21 \times 10^{-3} \text{ N}$. **(b)** Since $BF = \rho_B V_B g$, we find $\rho_B = 2\rho_o/3 = 533 \text{ kg/m}^3$.

- 15.55** A cubical copper block is 1.50 cm on each edge. **(a)** What is the buoyant force on it when it is submerged in oil for which $\rho = 820 \text{ kg/m}^3$? **(b)** What is the tension in the string that is supporting the block when submerged? $\rho_{\text{Cu}} = 8920 \text{ kg/m}^3$.

| (a) The buoyant force equals the weight of the displaced liquid, $BF = \rho_{\text{oil}} V_{\text{Cu}} g$, with the volume $V = 3.38 \times 10^{-6} \text{ m}^3$ and $\rho = 820 \text{ kg/m}^3$. Thus $BF = 0.027 \text{ N}$. **(b)** The forces acting on the block are the tension T up, BF up, and the block weight $\rho_{\text{Cu}} V_{\text{Cu}} g = 8920(3.38 \times 10^{-6})(9.8) = 0.295 \text{ N}$ acting downward. Then $T = 0.295 - 0.027 = 0.268 \text{ N}$.

- 15.56** A balloon having a mass of 500 kg remains suspended motionless in the air. If the air density is 1.29 kg/m^3 , what is the volume of the balloon in cubic meters?

| By equilibrium and Archimedes’ principle, $500g = 1.29gV$, or $V = 388 \text{ m}^3$.

- 15.57** A cylindrical wooden buoy, of height 3 m and mass 80 kg, floats vertically in water. If its specific gravity is 0.80, how much will it be depressed when a body of mass 10 kg is placed on its upper surface?

| By Archimedes’ principle, the submerged height, h , of the unloaded buoy is given by

$$\rho_{\text{water}} g A h = \rho_{\text{wood}} g A (3) \quad \text{or} \quad h = \frac{\rho_{\text{wood}}}{\rho_{\text{water}}} 3 = (0.80)(3) = 2.40 \text{ m}$$

Under loading, the submerged height is directly proportional to the total weight or mass.

$$\frac{h + \Delta h}{h} = \frac{80 + 10}{80} \quad \text{or} \quad \Delta h = \frac{10}{80} h = \frac{10}{80} 2.40 = \underline{0.30 \text{ m}}$$

- 15.58** A tank contains water on top of mercury. A cube of iron, 60 mm along each edge, is sitting upright in equilibrium in the liquids. Find how much of it is in each liquid. The densities of iron and mercury are $7.7 \times 10^3 \text{ kg/m}^3$ and $13.6 \times 10^3 \text{ kg/m}^3$, respectively.

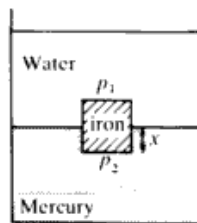

Fig. 15-15

Let x equal the distance submerged in mercury. Then $(0.06 - x)$ equals the distance protruding into the water. The net vertical force due to the liquids is $p_2 A - p_1 A$, where p_2, p_1 are the pressures at the lower and upper face of the block (see Fig. 15-15) and A is the face area of the block. For equilibrium we have the weight of the iron $w_i = p_2 A - p_1 A = (p_2 - p_1)A$. The pressure difference is just $p_2 - p_1 = \rho_w g(0.06 - x) + \rho_{Hg} g x$. Then $(p_2 - p_1)A = \rho_w g(0.06 - x)A + \rho_{Hg} g x A$. [Note that the two terms on the right represent the weight of displaced water and mercury, respectively; and the expression on the left is the buoyant force. Thus Archimedes' principle holds even when two (or more) liquids are displaced. This is true for any shape object.] We can now solve for x from the equilibrium equation, noting that $w_i = \rho_i g V_i = \rho_w g(0.06 - x)A + \rho_{Hg} g x A$; or canceling the g , we have

$$(7.7 \times 10^3 \text{ kg/m}^3)(0.06 \text{ m})^3 = (1.0 \times 10^3 \text{ kg/m}^3)(0.06 \text{ m} - x)(0.06 \text{ m})^2 + (13.6 \times 10^3 \text{ kg/m}^3)x(0.06 \text{ m})^2$$

$$\text{and} \quad 7.7(0.06) = (0.06 - x) + 13.6x \quad 0.40 = 12.6x$$

$x = 0.032 \text{ m} = \underline{32 \text{ mm}}$ = depth submerged in mercury, and $\underline{28 \text{ mm}}$ protrudes into water.

- 15.59** A slender homogeneous rod of length $2l$ floats partly immersed in water, being supported by a string fastened to one of its ends, as pictured in Fig. 15-16. If the specific gravity of the rod is 0.75, what is the fraction of the length of the rod that extends out of the water?

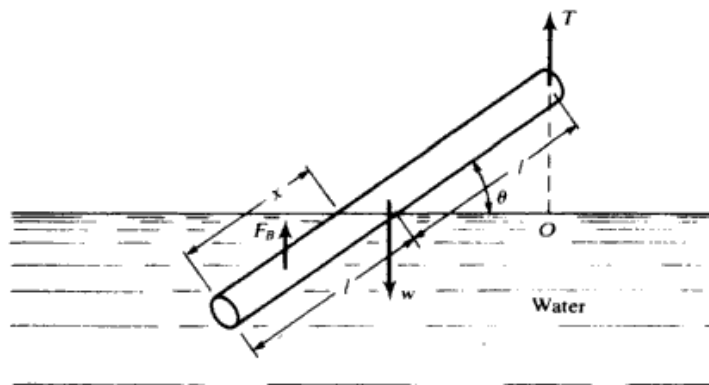

Fig. 15-16

Since the buoyant force acts through the center of gravity of the displaced water, the condition for rotational equilibrium is, taking moments about a point O along the line of action of T ,

$$0 = \sum \tau_O = w l \cos \theta - F_B \left(2l - \frac{x}{2}\right) \cos \theta = \rho_{\text{rod}} g A (2l) (l \cos \theta) - \rho_{\text{water}} g A x \left(2l - \frac{x}{2}\right) \cos \theta$$

$$= \left(\frac{1}{2} \rho_{\text{water}} g A \cos \theta\right) \left(x^2 - 4lx + 4 \frac{\rho_{\text{rod}}}{\rho_{\text{water}}} l^2\right) \quad \text{where } A = \text{cross sectional area}$$

From this, $x^2 - 4lx + 3.00l^2 = 0$, or $x = l, 3l$. Discarding the nonphysical root, we see that one-half the rod extends out of the water.

Strictly speaking, the above solution is only approximate since the water surface does not cut the rod perpendicularly. However, the error will be negligible if A is small.

- 15.60** The weight of a balloon and the gas it contains is 11.12 kN. If the balloon displaces 1132 m³ of air and the weight of 1 m³ of air is 12.3 N, what is the acceleration with which the balloon begins to rise?

▮ The equation of motion of the balloon is

$$\sum F = F_B - w = ma \quad \text{or} \quad a = \frac{F_B - w}{m} = \frac{(1132)(12.3) - (1.112 \times 10^4)}{(1.112 \times 10^4)/9.8} = 2.47 \text{ m/s}^2$$

Note that we have ignored viscous forces. This is justified if the velocity is negligible.

- 15.61** A small block of wood, of density $0.4 \times 10^3 \text{ kg/m}^3$, is submerged in water at a depth of 2.9 m. Find (a) the acceleration of the block toward the surface when the block is released, and (b) the time for the block to reach the surface. Ignore viscosity.

▮ (a) By Archimedes' principle, the net upward force on the block is $F = \rho_{\text{water}}gV - \rho_{\text{wood}}gV$, where V is the volume of the block. Then

$$a = \frac{F}{m} = \frac{\rho_{\text{water}}gV - \rho_{\text{wood}}gV}{\rho_{\text{wood}}V} = \left(\frac{\rho_{\text{water}}}{\rho_{\text{wood}}} - 1\right)g = \left(\frac{1}{0.4} - 1\right)(9.8) = 14.7 \text{ m/s}^2$$

$$(b) \quad s = \frac{1}{2}at^2 \quad \text{or} \quad t = \sqrt{\frac{2s}{a}} = \sqrt{\frac{2(2.9)}{14.7}} = 0.63 \text{ s}$$

- 15.62** A body of density ρ' is dropped from rest at a height h into a lake of density ρ , where $\rho > \rho'$. Neglect all dissipative effects and calculate (a) the speed of the body just before entering the lake, (b) the acceleration of the body while it is in the lake, and (c) the maximum depth to which the body sinks before returning to float on the surface.

▮ (a) The speed just before entering can be determined from conservation of mechanical energy in free fall, or directly from the kinematic equations of free fall, yielding $v = \sqrt{2gh}$. (b) The buoyant force of the lake, B , is greater than the weight of the body, w , since $\rho > \rho'$. Choosing upward as positive, we have

$$B - w = ma \quad \text{where} \quad B = \rho gV \quad w = \rho' gV \quad m = \rho' V \quad \text{and} \quad V = \text{volume of body}$$

Then, canceling V on both sides,

$$(\rho - \rho')g = \rho'a \quad \text{or} \quad a = g \frac{\rho - \rho'}{\rho'} = g \left(\frac{\rho}{\rho'} - 1\right), \quad \text{upward}$$

(c) To find the maximum depth we have $v^2 = v_0^2 + 2ay$, with v_0 the velocity at $y = 0$ (from part a), $v = 0$ is the velocity at maximum depth, and y is the negative displacement from the surface to the maximum depth. Then

$$v_0^2 = -2ay \quad \text{and} \quad (-y) = \text{depth} = \frac{v_0^2}{2a} = \frac{2gh}{2g\left(\frac{\rho}{\rho'} - 1\right)} = \frac{h\rho'}{\rho - \rho'}$$

- 15.63** A soap bubble has a radius of 5 cm. If the soap solution has a surface tension $T = 30 \times 10^{-3} \text{ N/m}$, what is the gauge pressure within the bubble?

▮ Consider a hemisphere of the bubble (Fig. 15-17). The downward force of surface tension on each of the two bubble surfaces, inside and outside, is $2\pi rT$. For both surfaces the total force F is $F = 2(2\pi rT) = \Delta p A$, where A is the area of the flat circular face of the hemisphere. (See, e.g., Prob. 15.36.) Since $A = \pi r^2$,

$$4\pi rT = \Delta p(\pi r^2) \quad \frac{4T}{r} = \Delta p \quad \Delta p = \frac{4T}{r} = \frac{4(30 \times 10^{-3})}{0.05} = 2.4 \text{ Pa}$$

- 15.64** Find an expression for the height h that a liquid of density ρ will rise in a capillary tube of radius r if the surface tension of the liquid is γ and the meniscus makes an angle θ with the tube, as shown in Fig. 15-18.

▮ γ is a force per unit length and points in different directions around the tube, as shown. At equilibrium,

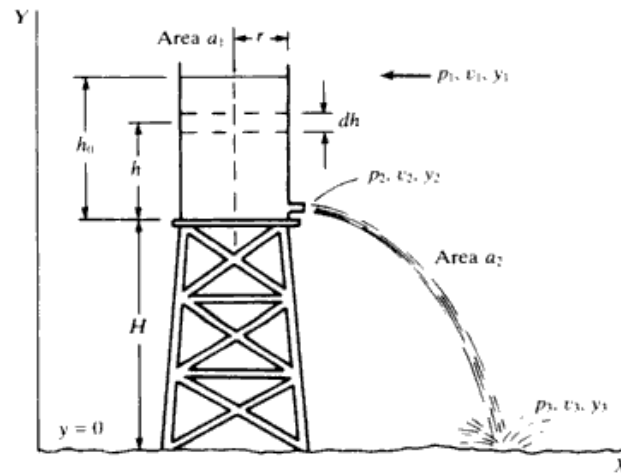

Fig. 16-8

16.27 The opening near the bottom of the vessel in Fig. 16-9 has an area a . A disk is held against the opening to keep the liquid, of density ρ , from running out.

(a) With what net force does the liquid press on the disk? (b) The disk is moved away from the opening a short distance. The liquid squirts out, striking the disk inelastically. After striking the disk, the water drops vertically downward. Show that the force exerted by the water on the disk is twice the force in part a.

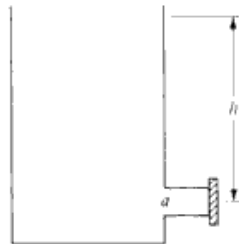

Fig. 16-9

| (a) The hydrostatic pressure on the inside surface of the disk is given by $p_i = p_{atm} + \rho gh$. The air pressure of the outside of the disk is $p_o = p_{atm}$. Since the disk has area a , the net outward force is $(p_i - p_o)a = \rho gha$. (b) Once the disk is removed, the fluid quickly attains a (relatively) steady flow. Torricelli's theorem implies that the exit speed is $v = \sqrt{2gh}$. Since friction is being ignored, this is the exit speed across the entire opening. Therefore the mass flux $\Phi = \rho av = \rho a\sqrt{2gh}$ and the flux of rightward momentum is $(\rho av)v = 2\rho gha$. If the water loses its entire rightward momentum as it strikes the disk, the disk must absorb momentum at the rate $2\rho gha$. That is, it will experience a rightward force $2\rho gha$, which is twice the hydrostatic force found in part a. Note that the force due to the atmosphere cancels on the left and right of the disk.

16.28 A flat plate moves normally toward a discharging jet of water at the rate of 3 m/s. The jet discharges water at the rate of $0.1 \text{ m}^3/\text{s}$ and at a speed of 18 m/s. (a) Find the force on the plate due to the jet and (b) compare it with that if the plate were stationary.

| We do part b first. With no other information we assume the plate stops the forward motion, but there is no bounce back, i.e., the water splashes along the plate at right angles to the original motion. Then the force normal to the plate equals the time rate of change of momentum along the direction of the water jet, or $F = (\rho av)v$, where the term in parentheses is the mass/time hitting the plate and a is the cross-sectional area of the jet. We are given $v = 18 \text{ m/s}$ and $av = 0.1 \text{ m}^3/\text{s}$. $\rho = 1000 \text{ kg/m}^3$. $F = (1000 \text{ kg/m}^3)(0.1 \text{ m}^3/\text{s})(18 \text{ m/s}) = 1800 \text{ N}$.

In part a the plate is moving toward the stream at 3 m/s. Two things effect a change in the momentum change/time. First if the liquid again splashes at right angles to the plate it has picked up a velocity of 3 m/s opposite to the jet's direction. The total change in forward velocity is therefore not $v = 18 \text{ m/s}$ but $= 18 + 3 = 21 \text{ m/s}$. Second, the mass of water hitting the plate per second increases from av to $a(v + 3)$. Noting

that $a = (0.1 \text{ m}^3/\text{s})/v$ we have for the force

$$F = \rho \left(\frac{0.1}{v} \right) (v+3)(v+3) = \frac{(1000 \text{ kg/m}^3)(0.1 \text{ m}^3/\text{s})(21 \text{ m/s})^2}{18 \text{ m/s}} = \underline{2450 \text{ N}}$$

- 16.29** A pump draws water from a reservoir and sends it through a horizontal hose. Since the water starts at rest and is set into motion by the pump, the pump must deliver power P to the water when the flow rate is Φ , even if fluid friction is negligible. A new pump is to be ordered which will pump water through the same system at a rate $\Phi' = 2\Phi$. What must be the power P' of the new pump? Assume that friction is still negligible.

| By the work-energy theorem,

$$P = \frac{\text{KE imparted to the water}}{\text{time}} = \frac{\text{KE}}{\text{vol. water}} \times \frac{\text{vol. water}}{\text{time}} \propto v^2 \times v = v^3$$

The mass flux Φ is proportional to v so that $P \propto \Phi^3$. Thus if $\Phi' = 2\Phi$, the new power $P' = 8P$.

- 16.30** The U tube of Fig. 16-10 contains a length L of a zero-viscosity fluid. Show that the fluid column oscillates like a simple pendulum of length $L/2$.

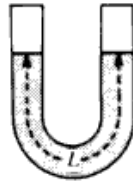

Fig. 16-10

| Let ρ denote the density of the fluid, M the mass of the fluid, and A the cross-sectional area of the tube. If one end of the fluid column is depressed a distance x below the equilibrium level, the other end must (assuming incompressibility) rise an equal distance x . The weight due to the height difference, $2x$, is a restoring force, $F = -\rho g A(2x) = -kx$. Thus we have SHM, of frequency

$$f = \frac{1}{2\pi} \sqrt{\frac{k}{M}} = \frac{1}{2\pi} \sqrt{\frac{2\rho g A}{M}} = \frac{1}{2\pi} \sqrt{\frac{2\rho g A}{\rho A L}} = \frac{1}{2\pi} \sqrt{\frac{g}{L/2}}$$

16.2 VISCOSITY, STOKES' LAW, POISEUILLE'S LAW, TURBULENCE, REYNOLDS NUMBER

- 16.31** A number of tiny spheres made of steel with density ρ_s , and having various radii r_s , are released from rest just under the surface of a tank of water, whose density is ρ .

(a) Show that the "net gravitational force" acting on a sphere (the combined effect of weight and buoyancy) has magnitude $(4\pi/3)r_s^3(\rho_s - \rho)g$. (b) Assuming that the fluid flow around each descending sphere is laminar, find the terminal speed v of a sphere in terms of r_s , ρ_s , ρ , and the viscosity η of the water.

| (a) (weight) - (buoyant force) = $\rho_s g \left(\frac{4}{3} \pi r_s^3 \right) - \rho g \left(\frac{4}{3} \pi r_s^3 \right) = \frac{4\pi}{3} r_s^3 (\rho_s - \rho) g$.

(b) When the sphere is descending at terminal speed, the net force must vanish, so we can equate the downward, "net gravitational force" to the upward viscous drag, which by Stokes' law = $6\pi\eta r_s v$. Thus

$$\frac{4\pi r_s^3}{3} (\rho_s - \rho) g = 6\pi\eta r_s v$$

Solving for the terminal speed, we obtain

$$v = \frac{2r_s^2}{9\eta} (\rho_s - \rho) g \tag{1}$$

- 16.32** Describe an idealized experiment for defining the coefficient of viscosity, η .

| Figure 16-11 shows two very large parallel plates A and B , separated by a distance d . The space between them is filled with fluid. A constant force F must be applied to plate B to keep it moving at a constant speed v_0 with respect to plate A . If a thin lamina of fluid at a uniform distance y from plate A moves with a speed

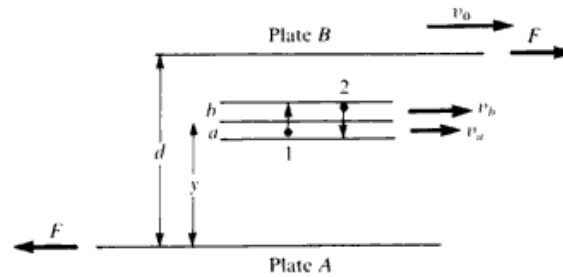

Fig. 16-11

$v(y) = v_0 y/d$, the flow is laminar. Then it is found that σ_s , the shear stress on the liquid, is proportional to v_0/d and the proportionality constant is the viscosity, η . Thus

$$\sigma_s = \eta v_0/d \tag{1}$$

From (1) it is seen that the SI unit of viscosity is the *pascal · second* or *poiseuille*: $1 \text{ Pl} = 1 \text{ Pa} \cdot \text{s} = 1 \text{ N} \cdot \text{s}/\text{m}^2$.

- 16.33** A rotating-cylinder viscometer is employed to measure the coefficient of viscosity of castor oil at a temperature of 20°C . The radius of the inner cylinder is $r_1 = 4.00 \text{ cm}$, and the radius of the outer cylinder is $r_2 = 4.28 \text{ cm}$. The inner cylinder is submerged in the oil to a depth $h = 10.2 \text{ cm}$. When the outer cylinder is rotating at $20.0 \text{ rev}/\text{min}$, the torsion balance reads a torque $T = 3.24 \times 10^{-2} \text{ N} \cdot \text{m}$. Find the viscosity of the castor oil.

▮ The cylindrical space between the outer and inner cylinders of the viscometer is not a bad approximation to the ideal flat-plate system of Fig. 16-11. Hence, by (1) of Prob. 16.32, $\eta = \sigma_s(d/v_0)$.

The wetted area of the inner cylinder is $a = 2\pi r_1 h$. Thus you have $\sigma_s = F/2\pi r_1 h$, where F is the drag force applied to the inner cylinder by the fluid, which is driven by the outer cylinder. This force results in a torque $T = r_1 F$, which can be read on the scale of the torsion balance. In terms of this torque, the shear stress is $\sigma_s = T/(2\pi r_1^2 h)$.

Since the inner cylinder is at rest, the relative speed v_0 of the two cylinders is given by $v_0 = \omega r_2$, where ω is the angular speed of the outer cylinder. And the distance between the cylinders is $d = r_2 - r_1$.

Using the above values of σ_s , v_0 , and d , you obtain

$$\eta = \frac{T(r_2 - r_1)}{2\pi \omega r_1^2 r_2 h}$$

Inserting the numerical values gives

$$\eta = \frac{(3.24 \times 10^{-2} \text{ N} \cdot \text{m})(0.28 \times 10^{-2} \text{ m})}{2\pi \left(\frac{20.0 \text{ rev}/\text{min} \times 2\pi \text{ rad}/\text{rev}}{60 \text{ s}/\text{min}} \right) (4.00 \times 10^{-2} \text{ m})^2 (4.28 \times 10^{-2} \text{ m})(10.2 \times 10^{-2} \text{ m})} = \underline{0.99 \text{ Pl}}$$

- 16.34** How fast will an aluminum sphere of radius 1 mm fall through water at 20°C once its terminal speed has been reached? Assume laminar flow. [sp gr (Al) = 2.7; $\eta_{\text{water}} = 8 \times 10^{-4} \text{ Pl}$.]

▮ Substituting the data in (1) of Prob. 16.31, we find $v = 4.6 \text{ m/s}$. (Actually, the assumption of laminar flow for this problem is not realistic; see Prob. 16.51.)

- 16.35** A typical riverborne silt particle has a radius of $20 \mu\text{m}$ and a density of $2 \times 10^3 \text{ kg}/\text{m}^3$. The viscosity of water is approximated by 1.0 mPl . Find the terminal speed with which such a particle will settle to the bottom of a motionless volume of water. (Unless the speed of internal fluid motions is smaller than this settling speed, the silt particles will not settle to the bottom.)

▮ Using (1) of Prob. 16.31,

$$v_t = \frac{2(20 \times 10^{-6})^2 [(2.0 - 1.0) \times 10^3](9.80)}{9(1.0 \times 10^{-3})} = 8.7 \times 10^{-4} \text{ m/s} = \underline{0.87 \text{ mm/s}}$$

- 16.36** Refer to Prob. 16.35. Suppose that you filled a 1-L bottle of 50-cm^2 cross section with water from a muddy river, such as the lower Mississippi. After all internal motions of the water itself had stopped, about how long would it take for all the silt to settle to the bottom?

▮ Since the height of the bottle will be about 200 mm , and since all silt particles (in particular, those at the

top of the bottle, which govern the overall settling time) take negligible time to achieve the terminal speed,

$$\text{overall settling time} = \frac{200 \text{ mm}}{0.87 \text{ mm/s}} \approx \underline{4 \text{ min}}$$

- 16.37** A tiny glass sphere (density 2600 kg/m^3) is let fall through a vat of oil ($\rho = 950 \text{ kg/m}^3$, $\eta = 0.21 \text{ Pl}$). In 100 s it is observed to drop 43 cm. How large is the sphere?

▮ Substitute the data and $v = 4.3 \times 10^{-3} \text{ m/s}$ in (1) of Prob. 16.31 to find $r_s = \underline{0.50 \text{ mm}}$.

- 16.38** In a certain centrifuge the liquid is rotated at 20 rev/s at a radius of 10 cm from the axis of rotation. Tiny spherical particles of radius b and density 1020 kg/m^3 in a dilute water solution (density 1000 kg/m^3) are placed in the centrifuge. Find the terminal speed with which they settle out of the solution. Ignore the effect of gravity. $\eta_{\text{water}} = 8.0 \times 10^{-4} \text{ Pl}$.

▮ The particle needs a centripetal force $m\omega^2 r = [(4\pi b^3 \rho)/3](20 \times 2\pi)^2 (0.10) = 6.75 \times 10^6 b^3 \text{ N}$ to keep it moving in a circle. A liquid (water-composed) particle also needs a centripetal force to keep it moving in a circle. Since only the surrounding liquid can supply the centripetal force, particles more dense than water will pass through to the outer edge of the centrifuge. This is then very similar to particles falling through water in a gravitational field. The actual static force supplied by the water in the centrifuge is just the effective “buoyant force” and must equal the centripetal force on an equivalent volume of water (using the same reasoning as that for Archimedes’ principle in a gravitational field). Hence, $\text{BF} = (1000/1020)6.75 \times 10^6 b^3 = 6.61 \times 10^6 b^3$. The remaining force is supplied by the viscous friction force ($6\pi\eta b v$). Hence, $6\pi\eta b v = 0.14 \times 10^6 b^3$, with $\eta = 8.0 \times 10^{-4} \text{ Pl}$, yields $v = \underline{9.3 \times 10^6 b^2 \text{ m/s}}$.

- 16.39** The viscous force on a liquid passing through a length L of pipe in laminar flow is given by $F_v = 4\pi\eta L v_m$, where η is the liquid viscosity and v_m is the maximum velocity of the liquid (i.e., along the central axis of the pipe). Find an expression for v_m in a horizontal segment of pipe in terms of p_1 and p_2 , the pressure at the back and forward ends of the pipe, and in terms of η , L , and r , the radius of the pipe.

▮ In steady flow the viscous force is balanced by the force due to the pressure difference at the back and front ends. Thus $p_1 \pi r^2 - p_2 \pi r^2 = 4\pi\eta L v_m$. Solving for v_m we have $v_m = [(p_1 - p_2)r^2]/(4\eta L)$.

- 16.40** What is the pressure drop (in mmHg) in the blood as it passes through a capillary 1 mm long and $2 \mu\text{m}$ in radius if the speed of the blood through the center of the capillary is 0.66 mm/s ? (The viscosity of whole blood is $4 \times 10^{-3} \text{ Pl}$).

▮ By the result of Prob. 16.39,

$$p_1 - p_2 = \frac{(4)(4 \times 10^{-3} \text{ Pa} \cdot \text{s})(10^{-3} \text{ m})(6.6 \times 10^{-4} \text{ m/s})}{(2 \times 10^{-6} \text{ m})^2} = 2600 \text{ Pa} = (2600 \text{ Pa})\left(\frac{1 \text{ mmHg}}{133 \text{ Pa}}\right) = \underline{19.5 \text{ mmHg}}$$

- 16.41** Using the result of Prob. 16.39, find an expression for the volume flow rate of fluid through a segment of pipe. In laminar flow the average flow velocity over a cross section is $v_m/2$.

▮ The volume flow rate, H , is the product of the cross-sectional area of the pipe and the average flow velocity. Thus $H = (\pi r^2 v_m)/2$. Using the expression for v_m from Prob. 16.39, we have $H = [\pi r^4 (p_1 - p_2)]/(8\eta L)$. This is known as *Poiseuille’s law*.

- 16.42** How much power is delivered at the back end of the capillary of Prob. 16.40 in pushing the blood through? Assume $p_1 = 10.0 \text{ kPa}$.

▮ $P \equiv \text{power} = \text{force} \times \text{velocity} = (p_1 \pi r^2)(v_m/2) = p_1 H$, by Prob. 16.41. Thus

$$P = \frac{(1.0 \times 10^4 \text{ N/m}^2)(3.14)(2 \times 10^{-6} \text{ m})^4 (0.26 \times 10^4 \text{ N/m}^2)}{8(4 \times 10^{-3} \text{ Pl})(10^{-3} \text{ m})} = \underline{4.1 \times 10^{-11} \text{ W}}$$

- 16.43** Assuming all else remains the same, how would the flow rate, H , change if the radius of a pipe is doubled? How would the power necessary to push the fluid through change? How would the fluid velocity change?

▮ Referring to Poiseuille’s law (Prob. 16.41), and assuming that p_1 , p_2 , η , and L remain constant, we see that doubling r will increase H sixteen-fold. For the power P we have from Prob. 16.42 $P = p_1 H$ and the power increases sixteen-fold as well. The velocity varies as r^2 (see Prob. 16.39) and therefore only quadruples.

$$\blacksquare \text{ (a)} \quad n = \frac{pV}{RT} = \frac{(1.52 \times 10^6)(10^{-2})}{(8.31)(298.15)} = \underline{6.135 \text{ mol}}$$

(b) The atomic mass of hydrogen is 1.008, so that 1 mol of hydrogen (H_2) contains 2.016 g, or 2.016×10^{-3} kg. The density of the hydrogen is then

$$\rho = \frac{nM}{V} = \frac{(6.13)(2.016 \times 10^{-3})}{10^{-2}} = \underline{1.24 \text{ kg/m}^3}$$

(c) The atomic mass of oxygen is 16, so that 1 mol of O_2 contains 32 g, or 32×10^{-3} kg. The density of the oxygen is then

$$\rho = \frac{nM}{V} = \frac{(6.13)(32 \times 10^{-3})}{10^{-2}} = \underline{19.6 \text{ kg/m}^3}$$

20.8 A compressor pumps 70 L of air into a 6-L tank with the temperature remaining unchanged. If all the air is originally at 1 atm, what is the final absolute pressure of the air in the tank?

| Use Boyle's law, since the temperature is constant.

$$p_0 V_0 = pV \quad p_0 = 1 \text{ atm} \quad V_0 = 70 + 6 = 76 \text{ L} \quad V = 6 \text{ L}$$

$$1(76) = p(6) \quad p = \underline{12.7 \text{ atm}} \text{ absolute pressure}$$

20.9 A 0.025-m^3 tank contains 0.084 kg of nitrogen gas (N_2) at a gauge pressure of 3.17 atm. Find the temperature of the gas in degrees Celsius. ($p_{\text{atm}} = 1.013 \times 10^5$ Pa).

| We note that the mass of 1 kmol of N_2 is 28 kg. From the ideal gas law, $pV = nRT$, with $n = 0.084/28$ kmol, $p = 3.17 + 1 = 4.17$ atm $= 4.17 \times 1.013 \times 10^5$ N/m², $R = 8314$ J/kmol \cdot K. Substituting,

$$4.17(1.013 \times 10^5)(0.025) = (0.084/28)(8314)T \quad \text{and}$$

$$T = \frac{28(4.17)(1.013 \times 10^5)(0.025)}{0.084(8314)} = 423 \text{ K} = \underline{150^\circ\text{C}}$$

20.10 A partially inflated balloon contains 500 m^3 of helium at 27°C and 1-atm pressure. What is the volume of the helium at an altitude of 18 000 ft, where the pressure is 0.5 atm and the temperature is -3°C ?

| For a confined gas,

$$\frac{p_1 V_1}{T_1} = \frac{p_2 V_2}{T_2} \quad \frac{1(500)}{300} = \frac{0.5V_2}{270} \quad V_2 = \frac{500(270)}{300(0.5)} = \underline{900 \text{ m}^3}$$

20.11 An air bubble released at the bottom of a pond expands to four times its original volume by the time it reaches the surface. If atmospheric pressure is 100 kPa, what is the absolute pressure at the bottom of the pond? Assume constant T .

$$\blacksquare \quad p_0 = p \frac{V}{V_0} = (100 \text{ kPa})(4) = \underline{400 \text{ kPa}}$$

20.12 A pressure gauge indicates the differences between atmospheric pressure and pressure inside the tank. The gauge on a 1.00-m^3 oxygen tank reads 30 atm. After some use of the oxygen, the gauge reads 25 atm. How many cubic meters of oxygen at normal atmospheric pressure were used? There is no temperature change during the time of consumption.

| Since the temperature is fixed we use Boyle's law to solve the problem. The total pressure in the tank has been reduced from 31 to 26 atm. At the latter pressure, the gas originally in the tank would occupy $\frac{31}{26} \text{ m}^3$. Since 1.00 m^3 remains in the tank, the amount of gas used was $\frac{5}{26} \text{ m}^3$ at 26 atm. At the same temperature and at atmospheric pressure, this would occupy a volume 26 times as large: $\underline{5.00 \text{ m}^3}$.

20.13 An air bubble of volume V_0 is released by a fish at a depth h in a lake. The bubble rises to the surface. Assume constant temperature and standard atmospheric pressure above the lake; what is the volume of the bubble just before touching the surface? The density of the water is ρ .

| Equating $p_0 V_0$ at depth h to pV at the surface leads to the equation $(p + \rho gh)V_0 = pV$, from which $V = (1 + \rho gh/p)V_0$.

- 20.14** If 2.1212 g of a monatomic gas occupies 1.49 L when the temperature is 0 °C and the pressure is 810.6 kPa, what is the gas?

▮ $pV = (m/M)RT$, where m = mass of gas and M = molecular weight.

$$(810.6 \times 10^3 \text{ Pa})(1.49 \times 10^{-3} \text{ m}^3) = \frac{(2.1212 \times 10^{-3} \text{ kg})(8.314 \text{ J/mol} \cdot \text{K})(273.15 \text{ K})}{M}$$

$$M = 3.99 \times 10^{-3} \text{ kg/mol} = 3.99 \text{ g/mol} \Rightarrow \text{gas is helium}$$

- 20.15** Use the general gas law to compute the density of methane, CH₄, at 20 °C and 5-atm pressure. A kilomole of methane is 16.0 kg.

▮ $pV = nRT$, with $T = 20 + 273 = 293 \text{ K}$, $R = 8314 \text{ J/kmol} \cdot \text{K}$, $n = 1 \text{ kmol}$, and $p = 5 \text{ atm} = 5(1.013 \times 10^5) \text{ N/m}^2$. Then

$$5(1.013 \times 10^5)V = 8314(293) \quad \text{and} \quad V = 4.8 \text{ m}^3 \quad d = \left(\frac{m}{V}\right) = \frac{16.0}{4.8} = 3.33 \text{ kg/m}^3$$

- 20.16** Solve Prob. 20.15 without finding the volume.

▮ Use $pV = (m/M)RT$ and $\rho = m/V$ to give

$$\rho = \frac{pM}{RT} = \frac{(5 \times 1.013 \times 10^5 \text{ N/m}^2)(16 \text{ kg/kmol})}{(8314 \text{ J/kmol} \cdot \text{K})(293 \text{ K})} = 3.33 \text{ kg/m}^3$$

- 20.17** A 100-ft³ volume of nitrogen at 27 °C and 15 lb/in² is compressed to fill a tank that is initially empty and has a volume of 5 ft³. If the final temperature of the nitrogen is 17 °C, what is the absolute pressure in the tank?

▮ Use the Kelvin scale and the general gas law in the form

$$\frac{p_1 V_1}{T_1} = \frac{p_2 V_2}{T_2} \quad \frac{15(100)}{273 + 27} = \frac{p_2(5)}{273 + 17} \quad p_2 = \frac{1500(290)}{5(300)} = 290 \text{ lb/in}^2$$

- 20.18** In the preparation of a sealed-off 20-mL tube at low temperatures, one drop (50 mg) of liquid nitrogen is accidentally sealed off in the tube. Find the nitrogen (N₂) pressure within the tube when the tube warms to 27 °C. Assume ideality. Express your answer in atmospheres (1 atm = 101.3 kPa).

▮ Use $pV = (mRT)/M$. M is 28 for N₂. Use $T = 300 \text{ K}$, $m = 5 \times 10^{-5} \text{ kg}$, $V = 2 \times 10^{-5} \text{ m}^3$, and $R = 8.314 \text{ kJ/kmol} \cdot \text{K}$, giving $p = 223 \text{ kPa} = 2.20 \text{ atm}$.

- 20.19** A car tire is filled to a gauge pressure of 24 psi (lb/in²) when the temperature is 20 °C. After the car has been running at high speed, the tire temperature rises to 60 °C. Find the new gauge pressure within the tire if the tire's volume does not change.

$$\text{▮} \quad p_1 = p_0 \frac{T_1}{T_0} = [(14.7 + 24) \text{ psi}] \frac{333 \text{ K}}{293 \text{ K}} = 44.0 \text{ psi} \quad \text{or} \quad 29.3 \text{ psi gauge pressure}$$

- 20.20** In a diesel engine, the cylinder compresses air from approximately standard pressure and temperature to about one-sixteenth the original volume and a pressure of about 50 atm. What is the temperature of the compressed air?

▮ Use $(P_1 V_1)/T_1 = (P_0 V_0)/T_0$ to find $T_1 = (P_1/P_0)(V_1/V_0)T_0 = (50)(\frac{1}{16})(273) = 853 \text{ K}$.

- 20.21** One way to cool a gas is to let it expand. Typically, a gas at 27 °C and a pressure of 40 atm might be expanded to atmospheric pressure and a volume 13 times larger. Find the new temperature of the gas.

▮ As in Prob. 20.20, $T_1 = (P_1/P_0)(V_1/V_0)T_0 = (\frac{1}{40})(13)(300) = 97.5 \text{ K} (-176 \text{ }^\circ\text{C})$.

- 20.22** A vertical right cylinder of height $h = 30.00 \text{ cm}$ and base area $A = 12.0 \text{ cm}^2$ is sitting open under standard temperature and pressure. A 5.0-kg piston that fits tightly into the cylinder is now placed into the cylinder and allowed to fall to an equilibrium height within it. What then is the height of the piston and what is the pressure within the cylinder? Assume the final temperature to be 0 °C.

▮ Pressure in the cylinder is increased by $\Delta p = (mg)/A = (5.0 \text{ kg})(9.8 \text{ m/s}^2)/(12.0 \times 10^{-4} \text{ m}^2) = 41 \text{ kPa}$, giving

- 20.74** A volume of 30 m^3 of air with 85% humidity at 20°C is passed through drying equipment that removes all the moisture. How many kilograms of water are removed?

▮ Use the ideal gas law and Table 20-1 to calculate the density of the water vapor at 20°C :

$$\rho = \frac{Mp}{RT} = \frac{(18 \text{ kg/kmol})(0.85 \times 2.31 \text{ kN/m}^2)}{(8.314 \text{ kN} \cdot \text{m/kmol} \cdot \text{K})(293 \text{ K})} = 0.0145 \text{ kg/m}^3$$

Hence, $(30 \text{ m}^3)(0.0145 \text{ kg/m}^3) = \underline{0.435 \text{ kg water removed}}$.

- 20.75** If the air in a room has a dew point of 11°C , what is its relative humidity at 21°C ?

▮ By the arguments of Probs. 20.71 and 20.73,

$$\text{R.H.} = \frac{\text{svp at } 11^\circ\text{C}}{\text{svp at } 21^\circ\text{C}} = \frac{1.34}{2.50} = 54\%$$

- 20.76** If a sample of air at 68°F and 55% relative humidity is slowly cooled, condensation will occur at what temperature?

▮ We again use the reasoning of Prob. 20.73. From Table 20-1, the saturated vapor pressure at $68^\circ\text{F} = 20^\circ\text{C}$ is 2.31 kPa. $(0.55)(2.31) = 1.27 \text{ kPa}$, which is the saturated vapor pressure at (approx.) $10^\circ\text{C} = \underline{50^\circ\text{F}}$.

- 20.77** The relative humidity of a room is 75% at 23°C . If the temperature falls to 19°C , what will the relative humidity be?

▮ We again use the reasoning of Prob. 20.73. From Table 20-1 the saturated vapor pressure of water vapor at 23°C is 2.88 kPa, giving an actual pressure of $(0.75)(2.88) = 2.16 \text{ kPa}$. From the table, the saturated vapor pressure at 19°C is 2.20 kPa. The new value is therefore relative humidity = $2.16/2.20 = \underline{98\%}$.

- 20.78** What is the dew point if the air has a relative humidity of 60% at 25°C ?

▮ From Table 20-1 the saturated vapor pressure of water vapor at 25°C is 3.26 kPa; hence $p = (0.60)(3.26) = 1.96 \text{ kPa}$. The dew point is the temperature at which the corresponding vapor pressure is the saturated vapor pressure. From the table, then, dew point $\approx \underline{17^\circ\text{C}}$.

- 20.79** If the normal lapse rate (decrease of temperature with altitude) prevails, and the temperature at ground level is 21°C , what will the air temperature be at height of 1100 m?

▮ The normal decrease of temperature with altitude is about 1°C per 110 m. $(1100/110)(1^\circ\text{C}) = 10^\circ\text{C}$ decrease. $21^\circ\text{C} - 10^\circ\text{C} = \underline{11^\circ\text{C}}$. (Note that $294 \text{ K} \rightarrow 284 \text{ K}$ is a small *percentage* decrease on the Kelvin scale.)

- 20.80** (a) Pilots of light planes must be careful to calculate the loads on warm days. Why must pilots leaving from or landing at high elevation (for example, Denver, Colorado, or Mexico City) be particularly careful?

(b) Compare the density of the air at 0°C to the density at 30°C . Assume identical pressures.

▮ (a) In relatively sparse air, there will be less lift on the wings of the airplane. Other factors being equal, take-off runs will be longer, climbing rates will be smaller, and the descent during landing approaches will be more rapid in the less dense air at high elevations and/or on warm days. (b) At constant pressure, density and temperature are inversely proportional $\rho_2/\rho_1 = T_1/T_2$. With $T_2 = 273.15 \text{ K}$ ($t_2 = 0^\circ\text{C}$) and $T_1 = 303.15 \text{ K}$ ($t_1 = 30^\circ\text{C}$), we find $\rho_2/\rho_1 = 303.15/273.15 = 1.11$. That is, at 0°C the density is 11 percent higher than it is at 30°C .

- 20.81** Compare the density of the air at Logan Airport in Boston (elevation 0 m) at 0°C to the density of air at Stapleton Field in Denver (elevation 1600 m) at 30°C . At constant temperature, the atmospheric pressure p obeys approximately the equation $p = p_0 e^{-z/8150}$ if the elevation z is expressed in meters, and p_0 is the atmospheric pressure at 0 m.

▮ We begin by determining the pressure at Stapleton Field with the help of the hydrostatic isothermal profile. Using the subscripts l and s to refer to Logan and Stapleton, we have

$$p_s = p_l e^{-(z_s - z_l)/8150}$$

We now determine the density which corresponds to p_s and the given temperature T_s . If the temperatures were equal ($T_s = T_i$), the density ratio ρ_s/ρ_i would equal the pressure ratio p_s/p_i (by Boyle's law). Since $T_s \neq T_i$, we must use the more general relationship $(p/\rho T) = \text{constant}$ (since the gas composition is assumed to be the same at the two locations). That is,

$$\frac{\rho_s}{\rho_i} = \frac{T_i p_s}{T_s p_i} = \frac{T_i}{T_s} e^{-(z_s - z_i)/8150}$$

With $T_i = 0^\circ\text{C} = 273.15\text{ K}$, $T_s = 30^\circ\text{C} = 303.15\text{ K}$, and $z_s - z_i = 1600\text{ m}$, we obtain

$$\frac{\rho_s}{\rho_i} = \left(\frac{273.15}{303.15}\right) e^{-(1600/8150)} = (0.9010) e^{-0.1963} = \underline{0.74}$$

Under the given conditions and assumptions, the density is 26 percent lower at Stapleton Field than at Logan Airport. Equivalently, the density at Logan Airport is 35 percent higher than that at Stapleton Field.

20.82 Derive the law of atmospheres from the Maxwell-Boltzmann statistical law which states that the number of particles (in an equilibrium ensemble) with energy E is proportional to $e^{-E/kT}$. Assume constant temperature over the heights being considered. (See Prob. 20.79.)

| Since the only term in the energy of air molecules that depends on the vertical height, z , is the gravitational potential energy, mgz (measured from ground zero), where m is the average mass of a molecule of air, the particle density $n_u(z)$ obeys (Maxwell-Boltzmann): $n_u(z) \propto e^{-[E(z)/kT]} = e^{-mgz/kT}$, and $[n_u(z)]/[n_u(o)] = e^{-mgz/kT}$. Since the density of air, ρ , is proportional to n_u , we have $\rho(z)/\rho(o) = e^{-mgz/kT}$. Finally, at constant temperature, $p(z) \propto \rho(z)$; so $p(z) = p(o)e^{-mgz/kT}$, which is the law of atmospheres.

20.83 Find the uniform temperature at which the ratio of the densities of mercury vapor at the top and bottom of a 2.0-m-high tank would be $1/e$. (Assume an ideal gas could be obtained.) (Molecular weight of mercury = 201.)

| From the law of atmospheres, $\rho_1/\rho_2 = \exp\{(-mgh)/(kT)\}$. Hence $1/2.718 = \exp\{[-m(9.8)(2)]/(kT)\}$ where $m = 201/N_A = 3.34 \times 10^{-25}\text{ kg}$. Invert and take natural logarithms of each side to find $1 = 19.6m/kT$. Solving for T yields $T = \underline{0.47\text{ K}}$.

20.84 A gas of dust particles fills a 2.0-m-high tank. At equilibrium (27°C), the density of particles at the top of the tank is $1/e$ the density at the bottom. Find the mass of a typical particle and find how many times more massive it is than a nitrogen molecule.

| Proceeding as in Prob. 20.83, $(mgh)/(kT) = 1$. This gives $m = (kT)/(gh) = 2.1 \times 10^{-22}\text{ kg}$. The mass of a nitrogen molecule is $28/N_A = 4.65 \times 10^{-26}\text{ kg}$ and so the mass of the dust particle is 4500 times greater.

20.85* Infer the law of atmospheres from the ideal gas law.

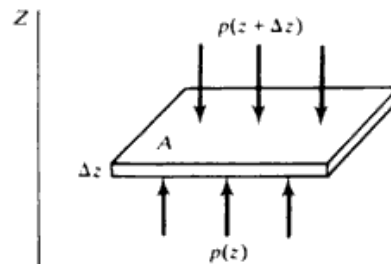

Fig. 20-7

| Figure 20-7 shows a thin slab of air at altitude z . For equilibrium of the slab,

$$[p(z) - p(z + \Delta z)]A = \rho g A \Delta z \quad \text{or} \quad \frac{dp}{dz} = -\rho g$$

From the ideal gas law,

$$p = \frac{\rho}{m} kT \quad \text{or} \quad \rho = \frac{m}{kT} p$$

where m is the average molecular mass for air. Thus

$$\frac{dp}{dz} = -\frac{mg}{kT}p$$

Ignoring the variation of T and g with altitude,

$$\int_{p_0}^p \frac{dp}{p} = -\frac{mg}{kT} \int_0^z dz \quad \text{and} \quad p = p_0 e^{-(mg/kT)z}.$$

20.86 Using the Dulong–Petit law, estimate the high-temperature specific heat capacity (in J/kg · K) for uranium metal ($M = 238$.)

▮ From the Dulong–Petit law the molar heat capacity at constant volume $C_V = 3R$. Thus, $c_v = C_V/M = [3(8314)]/238 = \underline{105 \text{ J/kg} \cdot \text{K}}$.

20.87 The Dulong–Petit law was used early in this century to determine the molecular weights of crystalline solids. A certain pure metal has a specific heat of 230 J/kg · K at high temperatures. What is the molecular weight of the metal?

▮ Again use $C_V = 3R$ and $M = C_V/c_v = 3(8314 \text{ J/kmol} \cdot \text{K})/(230 \text{ J/kg} \cdot \text{K}) = \underline{108 \text{ kg/kmol}}$.

20.88^c Show how the equipartition theorem (Prob. 20.38) leads to the law of Dulong and Petit.

▮ At high temperatures, it may be supposed that essentially all the internal energy of a metal is due to the vibrations of the atoms about their equilibrium positions in the crystalline lattice. If we picture each atom as connected to its neighbors by springs, then the atom will have kinetic and potential energies along three mutually perpendicular directions—six modes in all. By the equipartition theorem, its total energy will be $6(\frac{1}{2}kT) = 3kT$, giving a molar energy of $E = N_A(3kT) = 3RT$ and a molar heat capacity of $C_V = dE/dT = 3R$.

20.89^c The Dulong–Petit law holds true surprisingly well for solids if the temperature is high enough. To predict the behavior of the heat capacity at lower temperatures, a quantum-mechanical model must be used. One such model, originally used by Einstein, assumes that all atoms in a solid vibrate at the same frequency ν . The total energy of a solid of N atoms is then the same as the energy of $3N$ one-dimensional oscillators. The correct quantum-mechanical expression for the average energy of this collection of oscillators is $\langle E \rangle = 3N h \nu [\frac{1}{2} + 1/(e^{\beta h \nu} - 1)]$, where $\beta = 1/kT$, and $h = 6.63 \times 10^{-34} \text{ J} \cdot \text{s}$. Show that this model gives the molar heat capacity as

$$C = 3R \left(\frac{\Theta}{T} \right)^2 \frac{e^{\Theta/T}}{(e^{\Theta/T} - 1)^2}$$

where $\Theta = h\nu/k$.

▮ Writing A for Avogadro's number, we have, for one mole of material,

$$\langle E \rangle = 3A h \nu \left[\frac{1}{2} + \frac{1}{e^{h\nu/kT} - 1} \right] \quad (1)$$

so the molar heat capacity is given by

$$C = \frac{d\langle E \rangle}{dT} = 3A h \nu \frac{(-1)}{(e^{h\nu/kT} - 1)^2} \left(\frac{-h\nu}{kT^2} \right) e^{h\nu/kT} = 3(Ak) \left(\frac{h\nu}{kT} \right)^2 \frac{e^{h\nu/kT}}{(e^{h\nu/kT} - 1)^2} \quad (2)$$

Since $Ak = R$, the gas constant, Eq. (2) becomes

$$C = 3R \left(\frac{\Theta}{T} \right)^2 \frac{e^{\Theta/T}}{(e^{\Theta/T} - 1)^2} \quad (3)$$

where we have put $\Theta = h\nu/k$.

20.90 Refer to Prob. 20.89. Determine the behavior of C in the limit $T \gg \Theta$, and in the limit $T \ll \Theta$.

▮ For $T \gg \Theta$, we have $\Theta/T \ll 1$, so Eq. (3) yields

$$C = 3R \left(\frac{\Theta}{T} \right)^2 \frac{[1 + (\Theta/T) + \dots]}{[1 + (\Theta/T) + \dots - 1]^2} \rightarrow 3R \frac{(\Theta/T)^2 [1 + \Theta/T]}{(\Theta/T)^2} \rightarrow 3R$$

which is the Dulong–Petit result.

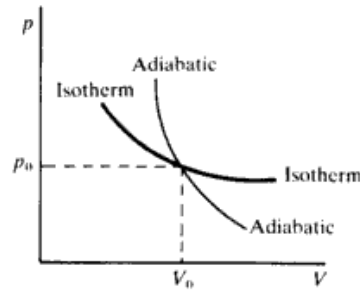

Fig. 21-2

- 21.26^c** In a p - V diagram (Fig. 21-2) an adiabatic and an isothermal curve for an ideal gas intersect. Show that the absolute value of the slope of the adiabatic is γ times that of the isotherm. Hence the adiabatic curve is steeper because the specific heat ratio γ is greater than 1.

▮ Denote the intersection point by (p_0, V_0) . Then the isothermal curve is given by $pV = p_0V_0$, or

$$p_{\text{iso}} = p_0 V_0 V^{-1} \quad (1)$$

while the adiabatic curve is described by $pV^\gamma = p_0V_0^\gamma$, or

$$p_{\text{ad}} = p_0 V_0^\gamma V^{-\gamma} \quad (2)$$

The slope of the isothermal curve at (p_0, V_0) is found by differentiating Eq. (1) and evaluating the derivative at $V = V_0$:

$$\left(\frac{dp}{dV}\right)_{\text{iso}} = -p_0 V_0 V^{-2} \Big|_{V_0} = \frac{-p_0}{V_0} \quad (3)$$

Using Eq. (2), the slope of the adiabatic curve at (p_0, V_0) is

$$\left(\frac{dp}{dV}\right)_{\text{ad}} = -\gamma p_0 V_0^\gamma V^{-\gamma-1} \Big|_{V_0} = \frac{-\gamma p_0}{V_0} \quad (4)$$

Equations (3) and (4) show that

$$\left|\left(\frac{dp}{dV}\right)_{\text{ad}}\right| = \gamma \left|\left(\frac{dp}{dV}\right)_{\text{iso}}\right|$$

for the curves intersecting at (p_0, V_0) .

21.2 THE FIRST LAW OF THERMODYNAMICS, INTERNAL ENERGY, p - V DIAGRAMS, CYCLICAL SYSTEMS

- 21.27** What is the change in internal energy of 0.100 mol of nitrogen gas as it is heated from 10 to 30 °C at (a) constant volume and (b) constant pressure?

▮ Internal energy for an ideal gas is linearly related to the temperature of the gas with $\Delta U = nC_V \Delta T$ so the answer to parts (a) and (b) is the same; $\Delta U = (0.100 \text{ mol})(4.96 \text{ cal/mol} \cdot \text{K})(20 \text{ K}) = 9.92 \text{ cal} = \underline{41.5 \text{ J}}$.

- 21.28** When 50 L of air at STP is isothermally compressed to 10 L, how much heat must flow from the gas? ($p_{\text{atm}} = 100 \text{ kPa}$.)

▮ Since the process is isothermal, and we assume an ideal gas, $\Delta U = 0$. Then $\Delta Q = \Delta W$. But $\Delta W = nRT \ln(V_2/V_1) = P_1 V_1 \ln(V_2/V_1)$. The substitution makes use of the ideal gas law, $P_1 V_1 = nRT_1$, and recognizes that T is constant. In this case, $\Delta Q = (1 \times 10^5)(5 \times 10^{-2}) \ln 10/50 = -8050 \text{ J}$; i.e., 8.05 kJ flows out.

- 21.29** An ideal gas in a cylinder is compressed adiabatically to one-third its original volume. During the process, 45 J of work is done on the gas by the compressing agent. (a) By how much did the internal energy of the gas change in the process? (b) How much heat flowed into the gas?

▮ In this case, $\Delta Q = 0$, so $\Delta U = -\Delta W = -(-45 \text{ J}) = \underline{45 \text{ J}}$; (b) the heat flow in the adiabatic process is zero.

- 21.30** In each of the following situations, find the change in internal energy of the system. (a) A system absorbs 500 cal of heat and at the same time does 400 J of work. (b) A system absorbs 300 cal and at the same time 420 J of work is done on it. (c) Twelve hundred calories is removed from a gas held at constant volume.

$$\begin{aligned} \text{(a)} \quad \Delta U &= \Delta Q - \Delta W = (500 \text{ cal})(4.184 \text{ J/cal}) - 400 \text{ J} = \underline{1700 \text{ J}} \\ \text{(b)} \quad \Delta U &= \Delta Q - \Delta W = (300 \text{ cal})(4.184 \text{ J/cal}) - (-420 \text{ J}) = \underline{1680 \text{ J}} \\ \text{(c)} \quad \Delta U &= \Delta Q - \Delta W = (-1200 \text{ cal})(4.184 \text{ J/cal}) - 0 = \underline{-5000 \text{ J}} \end{aligned}$$

Note that ΔQ is positive when heat is added to the system and ΔW is positive when the system does work. In the reverse cases, ΔQ and ΔW must be taken negative.

- 21.31** Rederive the result of Prob. 21.25 using the first law of thermodynamics and the facts that $C_p - C_v = R$ and $C_p/C_v = \gamma$ for an ideal gas, where C denotes molar heat capacity.

| Let the heat flow be denoted by ΔH , and the internal energy change by ΔE . Since the process is adiabatic, $\Delta H = 0$ and therefore $\Delta W = -\Delta E$. But $\Delta E = nC_v(T_B - T_A)$, and furthermore $R = C_p - C_v = (\gamma - 1)C_v$. Hence we can express the energy change as

$$\Delta E = \frac{nR}{(\gamma - 1)}(T_B - T_A)$$

But the ideal gas law yields $nRT = pV$, so we obtain

$$\Delta W = -\Delta E = \frac{-p_B V_B + p_A V_A}{\gamma - 1} = \frac{p_A V_A - p_B V_B}{\gamma - 1}$$

in agreement with the result of Prob. 21.25.

- 21.32** Find ΔW and ΔU for a 6-cm cube of iron as it is heated from 20 to 300 °C. For iron, $c = 0.11 \text{ cal/g} \cdot ^\circ\text{C}$ and the volume coefficient of thermal expansion is $\beta = 3.6 \times 10^{-5} \text{ } ^\circ\text{C}^{-1}$. The mass of the cube is 1700 g.

$$\text{|} \quad \Delta Q = cm \Delta T = (0.11 \text{ cal/g} \cdot ^\circ\text{C})(1700 \text{ g})(280 \text{ } ^\circ\text{C}) = 52 \text{ 000 cal}$$

The volume of the cube is $V = (6 \text{ cm})^3 = 216 \text{ cm}^3$. Using $(\Delta V)/V = \beta \Delta T$, we have

$$\Delta V = V\beta \Delta T = (216 \times 10^{-6} \text{ m}^3)(3.6 \times 10^{-5} \text{ } ^\circ\text{C}^{-1})(280 \text{ } ^\circ\text{C}) = 2.18 \times 10^{-6} \text{ m}^3$$

Then, assuming atmospheric pressure to be $1 \times 10^5 \text{ Pa}$,

$$\Delta W = p \Delta V = (1 \times 10^5 \text{ N/m}^2)(2.18 \times 10^{-6} \text{ m}^3) = 0.22 \text{ J}$$

But the first law tells us that

$$\Delta U = \Delta Q - \Delta W = (52 \text{ 000 cal})(4.184 \text{ J/cal}) - 0.22 \text{ J} = 218 \text{ 000 J} - 0.22 \text{ J} \approx 218 \text{ 000 J}$$

Note how very small the work of expansion against the atmosphere is in comparison to ΔU and ΔQ . Often ΔW can be neglected when dealing with liquids and solids.

- 21.33** A cubic meter of helium originally at 0 °C and 1-atm pressure is cooled at constant pressure until the volume is 0.75 m³. How much heat was removed?

| Use the general gas law to find the final temperature. Then use the first law of thermodynamics.

$$\frac{p_1 V_1}{T_1} = \frac{p_2 V_2}{T_2} \quad p_1 = p_2$$

Then

$$\frac{1}{273} = \frac{0.75}{T_2} \quad T_2 = 205 \text{ K}$$

$\Delta Q = \Delta U + \Delta W$; and for an ideal gas, $\Delta U = mc_v \Delta T$. Thus, $\Delta Q = mc_v \Delta T + p \Delta V = nC_v \Delta T + p \Delta V$. Noting that at STP, 1 kmol occupies 22.4 m³,

$$\Delta Q = \frac{1}{22.4} (3)(205 - 273) + \frac{(1.013 \times 10^5)(0.75 - 1)}{4184} = -9.11 - 6.05 = \underline{-15.2 \text{ kcal}}$$

The minus sign means that heat is removed.

- 21.34** The volume of 1 kg of water at 100 °C is about $1 \times 10^{-3} \text{ m}^3$. The volume of the vapor formed when it boils at this temperature and at standard atmospheric pressure is 1.671 m³. **(a)** How much work is done in pushing back the atmosphere? **(b)** How much is the increase in the internal energy when the liquid changes to vapor?

▮ (a) The work done by the water is given by

$$\Delta W = p_{\text{atm}} \Delta V = (1.013 \times 10^5 \text{ N/m}^2)[(1.671 - 0.001) \text{ m}^3] = \underline{169 \text{ kJ}}$$

(b) According to Table 17-2, the latent heat of vaporization of water is $L = 540 \text{ kcal/kg}$. This is the heat per kilogram that must be added to vaporize 100°C water at a constant pressure of 1 atm. The change in the internal energy of 1 kg of water when it is boiled at 1 atm is therefore given by

$$\Delta E = \Delta H - \Delta W = Lm - \Delta W = (540 \text{ kcal/kg})(1.00 \text{ kg})(4.184 \text{ kJ/kcal}) - (169 \text{ kJ}) = \underline{2090 \text{ kJ}}$$

21.35 A tank contains a fluid that is stirred by a paddle wheel. The power input to the paddle wheel is 2.24 kW. Heat is transferred from the tank at the rate of 0.586 kW. Considering the tank and the fluid as the system, determine the change in the internal energy of the system per hour.

▮
$$\Delta E = Q - W = -0.586 - (-2.24) = 1.654 \text{ kW} = 1.654 \text{ kJ/s} = 5954 \text{ kJ/h}$$

or about 6 MJ/h.

21.36 A spring having a spring constant 5 N/m is compressed 0.04 m, clamped in this configuration, and dropped into a container of acid in which the spring dissolves. How much potential energy is stored in the spring, and what happens to it when the spring dissolves?

▮ The spring in being compressed acquired elastic potential energy of amount $U_{\text{elastic}} = \frac{1}{2}kx^2 = \frac{1}{2}(5)(0.04)^2 = \underline{0.004 \text{ J}}$. When the spring is dissolved, this ordered potential energy is converted into disordered potential and kinetic energy of the system. Overall, energy is conserved.

21.37 One pound of fuel, having a heat of combustion of 10 000 Btu/lb, was burned in an engine that raised 6000 lb of water 110 ft. What percentage of the heat was transformed into useful work?

▮
$$\text{efficiency} = \frac{\text{work done by engine}}{\text{work equivalent of heat supplied}} = \frac{(6000 \text{ lb})(110 \text{ ft})}{(10\,000 \text{ Btu})(778 \text{ ft} \cdot \text{lb/Btu})} = 0.085 = \underline{8.5\%}$$

21.38 A sample containing 1.00 kmol of the nearly ideal gas helium is put through the cycle of operations shown in Fig. 21-3. BC is an isothermal, and $p_A = 1.00 \text{ atm}$, $V_A = 22.4 \text{ m}^3$, $p_B = 2.00 \text{ atm}$. What are T_A , T_B , and V_C ?

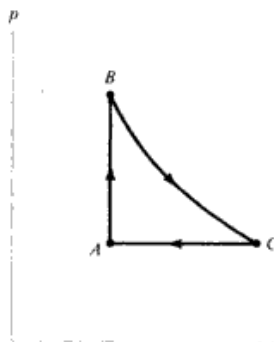

Fig. 21-3

▮ Applying the perfect gas law, we have

$$T_A = \frac{p_A V_A}{nR} = \frac{(1.013 \times 10^5 \text{ Pa})(22.4 \text{ m}^3)}{(1.00 \text{ kmol})(8.314 \times 10^3 \text{ J/kmol} \cdot \text{K})} = \underline{273 \text{ K}}$$

Because the process AB shown in Fig. 21-3 is isometric, $T_B = (p_B/p_A)T_A$. With $p_B = 2.00 \text{ atm} = 2p_A$, we find that $T_B = \underline{546 \text{ K}}$. The process CA is isobaric, so Charles' law applies. Thus $V_C/T_C = V_A/T_A$, so that $V_C = (T_C/T_A)V_A$. But BC is an isothermal process, so that $T_C = T_B = 2T_A$. Therefore $V_C = 2V_A = \underline{44.8 \text{ m}^3}$.

21.39 Refer to Prob. 21.38 and calculate the work output during the cycle.

▮ The work done by the gas along AB is zero, since $dV = 0$. The work done on the gas along the isotherm BC is

$$\Delta W_{BC} = \int_{V_B}^{V_C} p \, dV = \int_{V_B}^{V_C} \frac{RT_B}{V} \, dV = RT_B \ln \left(\frac{V_C}{V_B} \right) = RT_B \ln 2 = (8.314 \text{ kJ/kmol} \cdot \text{K})(546 \text{ K})(0.6931) = 3150 \text{ kJ}$$

$$\text{efficiency} = \frac{Q_h - Q_c}{Q_h} = \frac{T_h - T_c}{T_h} \quad \frac{500 - Q_c}{500} = \frac{590 - 390}{590}$$

$$500 - Q_c = 169 \text{ kcal} \quad \text{and} \quad Q_c = 331 \text{ kcal delivered to the sink}$$

$$W = Q_h - Q_c = 169 \text{ kcal} = 169(4.184) = \underline{710 \text{ kJ}}$$

22.14 A steam engine operating between a boiler temperature of 220 °C and a condenser temperature of 35 °C delivers 8 hp. If its efficiency is 30 percent of that for a Carnot engine operating between these temperature limits, how many calories are absorbed each second by the boiler? How many calories are exhausted to the condenser each second?

$$\text{actual efficiency} = (0.30)(\text{Carnot efficiency}) = (0.30)\left(1 - \frac{308}{493}\right) = 0.113$$

But from the relation

$$\text{efficiency} = \frac{\text{output work}}{\text{input heat}} \quad \text{input heat/s} = \frac{\text{output work/s}}{\text{efficiency}} = \frac{(8 \text{ hp})(746 \text{ W/hp})\left(\frac{1 \text{ cal/s}}{4.184 \text{ W}}\right)}{0.113} = \underline{12.7 \text{ kcal/s}}$$

To find the energy rejected to the condenser, we use the law of conservation of energy:

$$\text{input energy} = \text{output work} + \text{rejected energy}$$

Thus,

$$\begin{aligned} \text{rejected energy/s} &= (\text{input energy/s}) - (\text{output work/s}) = (\text{input energy/s})[1 - (\text{efficiency})] \\ &= (12.7 \text{ kcal/s})(1 - 0.113) = \underline{11.3 \text{ kcal/s}} \end{aligned}$$

22.15 How many kilograms of water at 0 °C can a freezer with a coefficient of performance 5 make into ice cubes at 0 °C with a work input of 3.6 MJ (one kilowatt-hour)? Use Table 17-1 for data.

By Prob. 22.3, the coefficient of performance is Q_c/W .

$$5 = \frac{mL}{3.6 \times 10^6 \text{ J}} = \frac{m(80 \text{ kcal/kg})(4184 \text{ J/kcal})}{3.6 \times 10^6 \text{ J}}$$

Solving, $m = \underline{54 \text{ kg}}$.

22.16 A refrigerator removes heat from a freezing chamber at -5 °F and discharges it at 95 °F. What is its maximum coefficient of performance?

For a Carnot refrigerator, $Q_c/W = T_c/(T_h - T_c)$. Use absolute temperatures (Rankine). Then

$$\frac{Q_c}{W} = \frac{-5 + 460}{(95 + 460) - (-5 + 460)} = \frac{455}{100} = \underline{4.55 \text{ coefficient of performance}}$$

22.17 A freezer has a coefficient of performance of 5. If the temperature inside the freezer is -20 °C, what is the temperature at which it rejects heat? Assume an ideal system.

$$\frac{Q_c}{W} = \frac{T_c}{T_h - T_c} \quad 5 = \frac{253}{T_h - 253}$$

Solving, we get $T_h = 304 \text{ K} = \underline{31 \text{ °C}}$.

22.2 ENTROPY

22.18* Give a mathematical definition of entropy and discuss its relation to the second law of thermodynamics.

Any thermodynamic system has a state function S , called the *entropy*. By this is meant that S —like p , V , and U —is always the same for the system when it is in a given equilibrium state. Entropy may be defined as follows. Let a system at absolute temperature T undergo an infinitesimal *reversible* process in which it absorbs heat ΔQ . Then the change in entropy of the system is given by

$$\Delta S = \frac{\Delta Q}{T} \quad \text{or} \quad dS = \frac{dQ}{T} \quad \text{for infinitesimals}$$

Note that dQ is not the differential of a true function. Entropy will have the units J/K.

The *Clausius equation*, $dS = dQ/T$, holds only for reversible processes. However, since S is a state function, the entropy change accompanying an irreversible process can be calculated by integrating dQ/T along the path of an arbitrary *reversible* process connecting the initial and final states.

The importance of the entropy function is exhibited in the following form of the *second law of thermodynamics*: *In any process, the total entropy of the system and its surroundings increases or (in a reversible process) does not change.* The second law applies to the system alone if the system is isolated; that is, if it in no way interacts with its surroundings.

22.19 Define entropy in terms of order/disorder, and discuss briefly.

▮ The second law of thermodynamics indicates that entropy is a measure of irreversibility. Irreversibility is associated, on the molecular level, with the increase of disorder. Molecular systems tend, as time passes, to become chaotic, and it is extremely unlikely that a more organized state, once left, will ever be regained. Another, fully equivalent, definition of entropy can be given from a detailed molecular analysis of the system. If a system can achieve the same state (i.e., the same values of p , V , T , and U) in Ω different ways (different arrangements of the molecules, for example), then the entropy of the state is $S = k \ln \Omega$, where \ln is the logarithm to base e and k is Boltzmann's constant, 1.38×10^{-23} J/K.

A state that can occur in only one way (one arrangement of its molecules, for example) is a state of high order. But a state that can occur in many ways is a more disordered state. To associate a number with disorder, the disorder of a state is taken proportional to Ω , the number of ways the state can occur. Because $S = k \ln \Omega$, the entropy is a measure of disorder.

Spontaneous processes in systems that contain many molecules always occur in a direction from

$$\left(\begin{array}{c} \text{state that can exist} \\ \text{in only a few ways} \end{array} \right) \rightarrow \left(\begin{array}{c} \text{state that can exist} \\ \text{in many ways} \end{array} \right)$$

Hence systems when left to themselves retain their original state of order or else increase their disorder.

22.20 For a heat engine, over one cycle, $\Delta S = \Delta E = 0$, since the engine returns to its original state. The first law of thermodynamics then gives for the work done by the engine per cycle.

$$W = Q_{\text{hot}} \left(1 - \frac{T_{\text{cold}}}{T_{\text{hot}}} \right) - T_{\text{cold}} \Delta S_{\text{total}} = W^* - T_{\text{cold}} \Delta S_{\text{total}} \quad (1)$$

where W^* is the work that would be done by a Carnot engine operating between the same two temperatures, and ΔS_{total} is the entropy change of the universe (in this case, the entropy change of the hot and cold reservoirs) during one cycle. Derive (1) and show its significance for the second law.

▮ For any engine operating between the temperature reservoirs, we have $W = Q_{\text{hot}} - Q_{\text{cold}}$, since $\Delta U = 0$ over a cycle. (Here Q_{cold} is defined as positive when heat leaves the engine, as is usual in engine and refrigerator problems.) In addition the changes in entropy of the hot and cold reservoirs are related to the heat transfers at constant temperature by $Q_{\text{hot}} = -T_{\text{hot}} \Delta S_{\text{hot}}$; $Q_{\text{cold}} = T_{\text{cold}} \Delta S_{\text{cold}}$. Then, noting $\Delta S_{\text{total}} = \Delta S_{\text{hot}} + \Delta S_{\text{cold}}$, we have $T_{\text{cold}} \Delta S_{\text{total}} = Q_{\text{cold}} - (T_{\text{cold}} Q_{\text{hot}})/T_{\text{hot}}$. Thus $W = Q_{\text{hot}} - Q_{\text{cold}} = Q_{\text{hot}} [1 - (T_{\text{cold}}/T_{\text{hot}})] - T_{\text{cold}} \Delta S_{\text{total}}$. Since the efficiency of a Carnot cycle is $W^*/Q_{\text{hot}} = 1 - (T_{\text{cold}}/T_{\text{hot}})$, we have the remainder of our result: $W = W^* - T_{\text{cold}} \Delta S_{\text{total}}$. We thus see that for a given Q_{hot} , $W \leq W^* \Leftrightarrow \Delta S \geq 0$. Or, in terms of efficiency, $\eta \leq \eta^* \Leftrightarrow \Delta S \geq 0$.

22.21 When 100 coins are tossed, there is one way that all can come up heads. There are 100 ways that only one tail is up. There are about 1×10^{29} ways that 50 heads can come up. One hundred coins are placed in a box with only one head up. They are shaken and then there are 50 heads up. What was the change in entropy of the coins caused by the shaking?

▮ From Prob. 22.19,

$$\begin{aligned} \Delta S &= k(\ln \Omega_f - \ln \Omega_i) = (1.38 \times 10^{-23} \text{ J/K})[\ln(1 \times 10^{29}) - \ln 100] \\ &= (1.38 \times 10^{-23} \text{ J/K})(27 \ln 10) = \underline{8.6 \times 10^{-22} \text{ J/K}} \end{aligned}$$

using $\ln 10 = 2.303$.

22.22* The number Ω of states accessible to N atoms of a monatomic ideal gas with a volume V , when the energy of the gas is between E and $E + dE$, can be shown to be $\Omega = A(N)V^N E^{3N/2}$, where the factor $A(N)$ depends only on N . (a) Find the entropy S as a function of V and E . (b) Using this entropy function and the definition of the Kelvin temperature, $1/T = (\partial S/\partial E)_V$, show that $E = \frac{3}{2}NkT$.

while the instantaneous transverse velocity is

$$\frac{\partial y}{\partial t} = kvA \sin [k(x - vt) + \delta] \quad (3)$$

Comparing Eqs. (2) and (3), we see that

$$\frac{\partial y}{\partial x} = -\frac{1}{v} \frac{\partial y}{\partial t} \quad (4)$$

as desired.

- 23.34^c** Give the general mathematical form of a wave traveling at constant speed, without dissipation, along the x axis, and show that it satisfies the standard wave equation.

▮ A wave $y(x, t)$ traveling along X with an unchanging form and speed v is given by $y = f(x \pm vt)$, where the minus and plus signs refer to wave propagation in the positive and negative X directions, respectively.

These functions satisfy the one-dimensional *wave equation*

$$\frac{\partial^2 y}{\partial x^2} = \frac{1}{v^2} \frac{\partial^2 y}{\partial t^2}$$

as can immediately be seen by setting $u = x \pm vt$ and using

$$\frac{\partial y}{\partial x} = \frac{dy}{du} \frac{\partial u}{\partial x} \quad \frac{\partial y}{\partial t} = \frac{dy}{du} \frac{\partial u}{\partial t} \quad \text{for either choice of } u$$

- 23.35** Sketch the profile of the wave $f(x, t) = Ae^{-B(x-vt)^2}$ at $t = 0$ s and $t = 1$ s, using $A = 1.0$ m, $B = 1.0 \text{ m}^{-2}$, and $v = +2.0$ m/s.

▮ See Fig. 23-5. Note that peak-to-peak distance divided by time interval equals v .

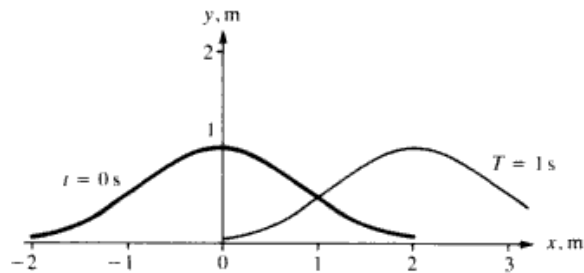

Fig. 23-5

- 23.36^c** Verify by partial differentiation that the wave function of Prob. 23.35 satisfies the one-dimensional wave equation.

▮ We begin with the proposed solution

$$f(x, t) = Ae^{-B(x-vt)^2} \quad (1)$$

Differentiating with respect to x , we find that

$$\frac{\partial f}{\partial x} = -2AB(x - vt)e^{-B(x-vt)^2} \quad (2)$$

and

$$\frac{\partial^2 f}{\partial x^2} = [-2AB + 4AB^2(x - vt)^2]e^{-B(x-vt)^2} \quad (3)$$

Differentiating with respect to t , we find that

$$\frac{\partial f}{\partial t} = 2ABv(x - vt)e^{-B(x-vt)^2} \quad (4)$$

support; at the other end, a tension of 100 N is applied. If a transverse blow is struck at one end of the tube, how long does it take to reach the other end?

$$\mathbf{I} \quad v = \sqrt{\frac{T_s}{\mu}} = \sqrt{\frac{100}{0.30}} = 18.3 \text{ m/s} \quad s = vt \quad \text{so} \quad 5.0 = 18.3t \quad \text{and} \quad t = \underline{0.27 \text{ s}}$$

- 23.44** Refer to Prob. 23.43. What frequency of vibration must be applied to the tube to produce a standing wave with four segments in the length of the tube? (This frequency is called the *fourth harmonic frequency*.)

\mathbf{I} We have $4(\lambda/2) = 5.0 \text{ m}$, or $\lambda = 2.5 \text{ m}$. Then $v = v/\lambda = 18.3/2.5 = \underline{7.3 \text{ Hz}}$.

- 23.45** Standing waves are produced in a rubber tube 12 m long. If the tube vibrates in five segments and the velocity of the wave is 20 m/s, what is (a) the wavelength of the waves, (b) the frequency of the waves?

$$\mathbf{I} \quad (\mathbf{a}) \quad 5\left(\frac{\lambda}{2}\right) = 12 \text{ m} \quad \text{or} \quad \lambda = \underline{4.8 \text{ m}}$$

$$(\mathbf{b}) \quad v = \frac{20 \text{ m/s}}{4.8 \text{ m}} = \underline{4.17 \text{ Hz}}$$

- 23.46** A string has a length of 0.4 m and a mass of 0.16 g. If the tension in the string is 70 N, what are the three lowest frequencies it produces when plucked?

$$\mathbf{I} \quad v = \sqrt{\frac{T_s}{\mu}} = \sqrt{\frac{70}{(0.00016/0.4)}} = \sqrt{175\,000} = 418 \text{ m/s.}$$

The fundamental frequency v_1 corresponds to a wavelength of $2(0.4) = 0.8 \text{ m}$; thus,

$$v_1 = \frac{418 \text{ m/s}}{0.8 \text{ m}} = \underline{523 \text{ Hz}}$$

The second and third harmonic frequencies are then $2v_1 = \underline{1046 \text{ Hz}}$ and $3v_1 = \underline{1569 \text{ Hz}}$.

- 23.47** The third overtone produced by a vibrating string 2 m long is 1200 Hz. What are the frequencies of the lower overtones and of the fundamental? What is the velocity of propagation?

\mathbf{I} The third overtone is the fourth harmonic v_4 . $v_4 = 1200 \text{ Hz}$ implies that $v_1 = 1200/4 = \underline{300 \text{ Hz}}$. Then $v_2 = 2v_1 = \underline{600 \text{ Hz}}$, and $v_3 = 3v_1 = \underline{900 \text{ Hz}}$. $v = \lambda_4 v_4 = (1 \text{ m})(1200 \text{ Hz}) = \underline{1200 \text{ m/s}}$ (or $v = \lambda_1 v_1 = (4 \text{ m})(300 \text{ Hz}) = 1200 \text{ m/s}$).

- 23.48** A 160-cm-long string has two adjacent resonances at frequencies of 85 and 102 Hz. (a) What is the fundamental frequency of the string? (b) What is the length of a segment at the 85-Hz resonance? (c) What is the speed of the waves on the string?

\mathbf{I} (a) The fundamental is $f_1 = v/(2L)$, the n th harmonic frequency is $nf_1 = 85 \text{ Hz}$ while the next harmonic frequency is $(n+1)f_1 = 102 \text{ Hz}$. From these we obtain $f_1 = \underline{17 \text{ Hz}}$ and $n = 5$. (b) For $n = 5$, there are five segments; the length of each is $160/5 = \underline{32 \text{ cm}}$. (c) From $f_1 = 17 = v/[2(1.6)]$, $v = \underline{54.4 \text{ m/s}}$.

- 23.49** A vertically suspended 200-cm length of string is given a tension equal to the weight of an 800-g mass. The string is found to resonate in three segments to a frequency of 480 Hz. What is the mass per unit length of the string?

\mathbf{I} In the third harmonic, $(3\lambda)/2 = 2.00 \text{ m}$; so that $v = f\lambda = 480(1.33) = 640 \text{ m/s}$. We then use the relation $v^2 = T/\mu$ to find $\mu = (mg)/v^2 = [0.800(9.80)]/640^2 = \underline{1.91 \times 10^{-5} \text{ kg/m}}$.

- 23.50** The equation for a particular standing wave on a string is $y = 0.15 (\sin 5x \cos 300t) \text{ m}$. Find the (a) amplitude of vibration at the antinode, (b) distance between nodes, (c) wavelength, (d) frequency (e) speed of the wave.

\mathbf{I} (a) By comparison with $y_0 = A \sin [(2\pi x)/\lambda] \cos (2\pi ft)$ we have $A = \underline{0.15 \text{ m}}$. (b) When the argument of the sine = $0, \pi, 2\pi, \dots$, we have nodes. Since $x = 0$ is a node we have for the next node $5x = \pi$ and $x = \pi/5 = \underline{0.628 \text{ m}}$. (c) The wavelength is twice this, so $\lambda = (2\pi)/5 = \underline{1.26 \text{ m}}$. (d) Since $2\pi f = 300$, $f = 150/\pi = \underline{47.7 \text{ Hz}}$ and (e) $v = \lambda f = [(2\pi)/5](150/\pi) = \underline{60 \text{ m/s}}$.

- 23.51** An organ pipe 1 ft long is open at both ends. If the velocity of sound is 1100 ft/s, what are the frequencies of the fundamental and of the first two overtones?

▮ As can be seen from Fig. 23-8, $n(\lambda/2) = L$ holds for an open organ pipe as well as a string. Thus, the fundamental frequency is $\nu_1 = v/2L = (1100 \text{ ft/s})/2 \text{ ft} = \underline{550 \text{ Hz}}$. The first overtone is the second harmonic, and $\nu_2 = 2\nu_1 = 2(550) = \underline{1100 \text{ Hz}}$. Similarly $\nu_3 = 3\nu_1 = 3(550) = \underline{1650 \text{ Hz}}$ (second overtone).

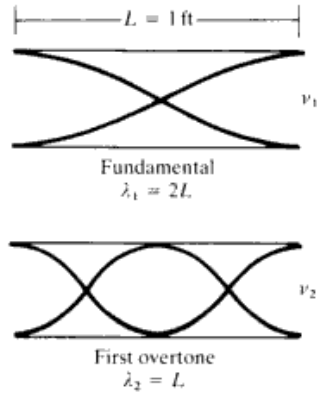

Fig. 23-8

- 23.52** A closed organ pipe 2.5 ft long is sounded. If the velocity of the sound is 1100 ft/s, what are the fundamental frequency and the first two overtones?

▮ For a “closed” pipe (that is, open at one end) $(2n - 1)(\lambda/4) = L$, as can be seen from Fig. 23-9. Hence $\nu_{2n-1} = (2n - 1)v/4L = (2n - 1)\nu_1$, so only the odd harmonics appear. For our case, $\lambda_1 = 4L = 4(2.5) = 10 \text{ ft}$. $v = \nu_1\lambda_1$ or $1100 = \nu_1(10)$ and $\nu_1 = \underline{110 \text{ Hz}}$. The first overtone is the third harmonic, so $\lambda_3 = 4L/3$ and $\nu_3 = v/\lambda_3 = 3v/4L = 3\nu_1 = 3(110) = \underline{330 \text{ Hz}}$. Similarly, $\nu_5 = 5\nu_1 = \underline{550 \text{ Hz}}$.

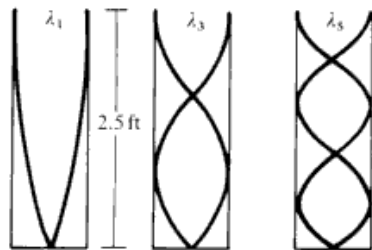

Fig. 23-9

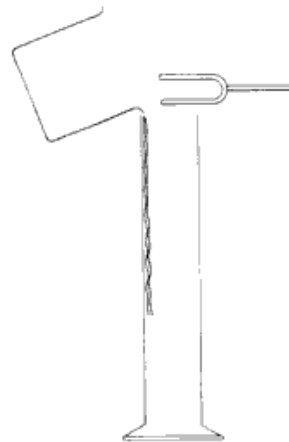

Fig. 23-10

- 23.53** A sounding tuning fork whose frequency is 256 Hz is held over an empty measuring cylinder. See Fig. 23-10. The sound is faint, but if just the right amount of water is poured into the cylinder, it becomes loud. If the optimal amount of water produces an air column of length 0.31 m, what is the speed of sound in air to a first approximation?

▮ The loudest sound will be heard at resonance, when the frequency of vibration of the air column in the cylinder is the same as that of the tuning fork. Since the air column is open at one end and closed at the other, we conclude that the wavelength of the vibration is four times the length of the column: $\lambda = 4L = (4)(0.31 \text{ m}) = 1.24 \text{ m}$. Here we have assumed that the observed resonant oscillation of the air column is its *fundamental* oscillation. Since the frequency $\nu = 256 \text{ Hz}$, the sound speed $v = \nu\lambda = \underline{317 \text{ m/s}}$. This is an underestimate since the displacement antinode (or the pressure node) which is located a distance of

23.59^c A uniform string (length L , linear density μ , and tension F) is vibrating with amplitude A_n in its n th mode. Show that its total energy of oscillation is given by $E = \pi^2 v_n^2 A_n^2 \mu L$.

▮ The displacement of the string is given by

$$y(x, t) = A_n \sin \frac{n\pi x}{L} \cos(2\pi v_n t + \delta)$$

so the transverse velocity is

$$\frac{\partial y}{\partial t} = -2\pi v_n A_n \sin \frac{n\pi x}{L} \sin(2\pi v_n t + \delta)$$

The string's total energy of oscillation is equal to the maximum kinetic energy. (Note that *all* points on the string achieve their maximum kinetic energy at the same time, when $y = 0$ for all x .) Since $dm = \mu dx$, we have

$$E = K_{\max} = \max \left[\frac{1}{2} \int \left(\frac{\partial y}{\partial t} \right)^2 dm \right] = \max \left[\frac{1}{2} \int_0^L \mu \left(\frac{\partial y}{\partial t} \right)^2 dx \right]$$

The maximum value occurs when $\sin^2(2\pi v_n t + \delta) = 1$, so we find that

$$E = \frac{\mu}{2} (2\pi v_n A_n)^2 \int_0^L \sin^2 \frac{n\pi x}{L} dx$$

The average value of $\sin^2[(n\pi x)/L]$ over any number of half cycles is given by $\frac{1}{2}$, so the integral has the value $L/2$. Therefore $E = 2\pi^2 \mu v_n^2 A_n^2 (L/2) = \pi^2 v_n^2 A_n^2 \mu L$, as desired. [Compare with the result for a traveling wave, Prob. 23.29.]

23.60 A taut square membrane 85 cm on a side is fastened to a rigid frame on its edges. When tapped lightly at its center, it gives off a tone of about 200 Hz. Assuming it to be resonating in the mode shown in Fig. 23-12, what is the wave speed in the membrane?

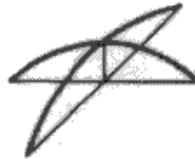

Fig. 23-12

▮ The resonant frequencies of a rectangular drumhead are given by the formula

$$f_{mn} = \frac{v}{2} \sqrt{\left(\frac{m}{L_x}\right)^2 + \left(\frac{n}{L_y}\right)^2}$$

where m and n are the respective numbers of half-wavelengths that fit into the dimensions L_x and L_y . Figure 23-12 shows the mode $m = n = 1$; hence,

$$200 = \frac{v}{2} \sqrt{\frac{2}{(0.85)^2}}$$

giving $v = 240$ m/s.

24.1 SOUND VELOCITY; BEATS; DOPPLER SHIFT

- 24.1** Helium is a monatomic gas that has a density of 0.179 kg/m^3 at a pressure of 76 cm of mercury and a temperature of 0°C . Find the speed of compressional waves (sound) in helium at this temperature and pressure.

| $v = \sqrt{B/\rho}$, where B is the adiabatic bulk modulus. For an ideal gas, $B = \gamma p$ (see Prob. 21.24), and $\gamma = 1.67$ for a monatomic gas. Then

$$v = \sqrt{\frac{1.67(1.013 \times 10^5 \text{ N/m}^2)}{0.179 \text{ kg/m}^3}} = \underline{972 \text{ m/s}}$$

- 24.2** Using the fact that hydrogen gas consists of diatomic molecules with $M = 2 \text{ kg/kmol}$, find the speed of sound in hydrogen at 27°C .

| For ideal gases $v = [(\gamma p)/\rho]^{1/2} = [(\gamma RT)/M]^{1/2}$, so

$$v = [(1.40)(8314 \text{ J/kmol} \cdot \text{K})(300 \text{ K})/(2 \text{ kg/kmol})]^{1/2} = \underline{1321 \text{ m/s}}$$

- 24.3** From the fact that the molecular weight of oxygen molecules is 32 kg/kmol , find the speed of sound in oxygen at 0°C .

| As in Prob. 24.2, $v = [(1.40)(8314)(273)/32]^{1/2} = \underline{315 \text{ m/s}}$

- 24.4** The velocity of sound in a container of hydrogen at -73°C is approximately 4000 ft/s . What would the velocity be (in ft/s) if the temperature of the hydrogen were raised to 127°C without a change in volume?

| Since $v = [(\gamma RT)/M]^{1/2}$ we have, assuming constant γ , $v = v_0 \sqrt{T/T_0} = (4000 \text{ ft/s})\sqrt{(400 \text{ K})/(200 \text{ K})} = \underline{5657 \text{ ft/s}}$.

- 24.5** What is the speed of sound in air when the temperature is 35°C ? The speed of sound in air at 0°C is 331 m/s .

| $v \propto \sqrt{T} = \sqrt{273 + t}$; so if $v_0 =$ speed at $t = 0^\circ\text{C}$, $v = v_0(1 + t/273)^{1/2} = 331(1 + 35/273)^{1/2} = \underline{351.6 \text{ m/s}}$.

- 24.6** By how much must the temperature of air near 0°C be changed to cause the speed of sound in it to change by 1 percent?

|
$$\frac{(273 + t)^{1/2} - (273)^{1/2}}{273^{1/2}} = 0.01$$

Noting $[1 + t/273]^{1/2} \approx 1 + t/546$, we get $(t/546)(100) = 1.0$, which leads to $t = \underline{5.5^\circ\text{C}}$.

- 24.7** A certain gas mixture is composed of two diatomic gases (molecular weights M_1 and M_2). The ratio of the masses of the two gases in a given volume is $m_2/m_1 = r$. Show that the speed of sound in the gas mixture is as follows if the gases are ideal:

$$v = \sqrt{\frac{1.40RT}{M_1 M_2} \frac{M_2 + rM_1}{1 + r}}$$

| $v = [(\gamma p)/\rho]^{1/2}$, but $\rho = m/V = (m_1 + m_2)/V$, and (Dalton's law) $p = p_1 + p_2 = (n_1 + n_2)[(RT)/V]$, with $n_1 = m_1/M_1$ and $n_2 = m_2/M_2$, so that $p/\rho = [(m_1/M_1 + m_2/M_2)RT]/(m_1 + m_2) = [(1/M_1 + r/M_2)RT]/(1 + r)$, with $r = m_2/m_1$. Substitute p/ρ and $\gamma = 1.40$ into the expression for v to find the required result.

- 24.8** Suppose (with Newton) that the compressional vibration in a gas were isothermal in character rather than adiabatic. Find the expression equivalent to $(\gamma p/\rho)^{1/2}$ for the speed of sound in that case.

| For pV a constant, $\Delta(pV) = p \Delta V + V \Delta p = 0$, or $\Delta V/\Delta p = -V/p$. But $\Delta V/\Delta p = -V/B$ from the definition of B . Therefore, $B = p$ and $v = (B/\rho)^{1/2} = (p/\rho)^{1/2}$. Thus $v_{ad}/v_{iso} = \gamma^{1/2}$.

- 24.9** A 1000-Hz sound wave in air strikes the surface of a lake and penetrates into the water. What are the frequency and wavelength of the wave in water? Assume that the speed of sound in water is 1500 m/s.

▮ The number of complete waves passing any point in air and in water in unit time is the same, so $f = 1000$ Hz for both media. Therefore,

$$\lambda_w = \frac{v_w}{f} = \frac{1500 \text{ m/s}}{1000 \text{ s}^{-1}} = \underline{1.5 \text{ m}}$$

- 24.10** An underwater sonar source operating at a frequency of 60 kHz directs its beam toward the surface. What is the wavelength of the beam in the air above? What frequency sound due to the sonar source does a bird flying above the water hear? Assume that v in air = 330 m/s.

▮ As indicated in Prob. 24.9, f remains constant—in this case at 60 kHz. The wavelength = $v/f = 330/(6.0 \times 10^4) = \underline{5.5 \text{ mm}}$.

- 24.11** Define *pitch*, *loudness*, *quality*, *decibel*, *reverberation time*, *interference*, *beats*, *Doppler effect*, *supersonic velocity*, *shock wave*, and *Mach number*.

▮ *Pitch* is a sound characteristic that depends on the frequency of the fundamental. Higher pitch means higher frequency.

Loudness refers to the strength of the auditory sensation produced by a sound. It depends on the intensity and frequency of the sound.

The *quality* (or *timbre*) of a sound depends on the number and intensities of the overtones.

Decibel (dB) is the unit of intensity-level, n , of sound. One dB is ten times the log of an intensity ratio of 1.26:1. The equation for n is $n = 10 \log (I/I_0)$, where $I_0 = 10^{-12} \text{ W/m}^2$.

The *reverberation time* of a room is the time required for the sound level to fall 60 dB after the sound source is shut off; that is, for the intensity to decrease by a factor of a million.

Interference is the superposition of sound waves to produce either constructive or destructive addition.

Beats are fluctuations in sound intensity that occur when there is interference between two sound waves of equal intensity and slightly different frequency.

The *Doppler effect* is the apparent change in frequency as the source of a sound and an observer of the sound move relative to each other.

A *supersonic velocity* is one that is greater than the local velocity of sound.

A *shock wave* is the wave motion accompanying objects traveling at supersonic speeds.

Mach number is the ratio of the velocity of an object, or of a shock front, to the local velocity of sound.

- 24.12** Two closed organ pipes sounded simultaneously give five beats per second between the fundamentals. If the shorter pipe is 1.1 m long, find the length L of the longer pipe. Assume that v in air = 340 m/s.

▮ Each pipe is occupied by a quarter-wave (refer to Prob. 23.52); hence,

$$5 \text{ Hz} = \nu_1 - \nu_2 = \frac{340 \text{ m/s}}{4.4 \text{ m}} - \frac{340 \text{ m/s}}{4L}$$

Solving, $L = \underline{1.18 \text{ m}}$.

- 24.13** Two open organ pipes, one 2.5 ft and one 2.4 ft in length, are sounded simultaneously. How many beats per second will be produced between the fundamental tones if the velocity of the sound is 1100 ft/s?

▮ Each pipe is occupied by a half-wave (see Prob. 23.51), so

$$\nu_1 - \nu_2 = \frac{1100 \text{ ft/s}}{4.8 \text{ ft}} - \frac{1100 \text{ ft/s}}{5.0 \text{ ft}} = \underline{9 \text{ Hz}}$$

- 24.14** Four beats per second are heard when two tuning forks are sounded simultaneously. After attaching a small piece of tape to one prong of the second tuning fork, the two tuning forks are sounded again and two beats per second are heard. If the first fork has a frequency of 180 Hz, what must the original frequency of the second fork have been?

▮ The frequency of the second fork must be higher than that of the first fork or adding the tape would have *increased* the number of beats. Therefore, $\nu_2 - 180 = 4$ or $\nu_2 = \underline{184 \text{ Hz}}$.

- 24.15*** Some of the low keys of the piano have two strings. On a particular key one of the strings is tuned correctly

$V = q/C$ gives

$$\frac{q'_3}{3 \times 10^{-6} \text{ F}} = \frac{q'_4}{4 \times 10^{-6} \text{ F}} \quad \text{or} \quad q'_3 = 0.75q'_4$$

Substitution of this in the previous equation gives

$$0.75q'_4 + q'_4 = 6 \mu\text{C} \quad \text{or} \quad q'_4 = \underline{3.43 \mu\text{C}}$$

Then $q'_3 = 0.75q'_4 = \underline{2.57 \mu\text{C}}$.

- 26.107** Two capacitors, $C_1 = 3 \mu\text{F}$ and $C_2 = 6 \mu\text{F}$, are connected in series and charged by connecting a battery of voltage $V = 10 \text{ V}$ in series with them. They are then disconnected from the battery, and the loose wires are connected together. What is the final charge on each?

| The capacitors are charged in series so they originally have equal charges. When the loose wires are reconnected, they neutralize each other giving zero final charge.

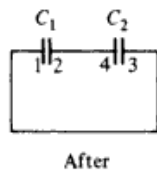
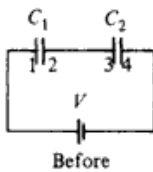

Fig. 26-33

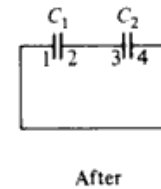
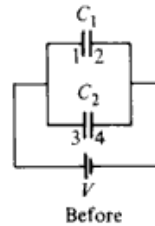

Fig. 26-34

- 26.108** Repeat Prob. 26.107 if after being disconnected from the battery, the capacitors are disconnected from each other. They are now reconnected as shown in Fig. 26-33. What is the final charge on each?

| The original charge on each is $Q = C_{\text{eq}}V = 20 \mu\text{C}$. After being connected as shown, $Q_1 + Q_2 = 2Q = 40 \mu\text{C}$. Also $V_1 = V_2$ and so $Q_1/C_1 = Q_2/C_2$. Solving these two equations simultaneously gives for the two charges $\underline{26.7 \mu\text{C}}$ on the $6 \mu\text{F}$ and $\underline{13.3 \mu\text{C}}$ on the $3 \mu\text{F}$.

- 26.109** If two capacitors $C_1 = 4 \mu\text{F}$ and $C_2 = 6 \mu\text{F}$ are originally connected to a battery $V = 12 \text{ V}$, as shown in Fig. 26-34, and then disconnected and reconnected as shown, what is the final charge on each capacitor?

| Originally, $Q_1 = 48 \mu\text{C}$, $Q_2 = 72 \mu\text{C}$; hence, $Q'_1 + Q'_2 = 72 - 48 = 24 \mu\text{C}$. Also, $V'_1 = V'_2$ gives $Q'_1/C_1 = Q'_2/C_2$. Solving simultaneously gives $\underline{9.6}$ and $\underline{14.4 \mu\text{C}}$.

CHAPTER 27

Simple Electric Circuits

27.1 OHM'S LAW, CURRENT, RESISTANCE

TABLE 27-1 Resistivities (ρ) at 20 °C and Temperature Coefficients (α).

material	$\rho, \Omega \cdot \text{m}$	$\alpha, ^\circ\text{C}^{-1}$
Silver	1.6×10^{-8}	3.8×10^{-3}
Copper	1.7×10^{-8}	3.9×10^{-3}
Aluminum	2.8×10^{-8}	3.9×10^{-3}
Tungsten	5.6×10^{-8}	4.5×10^{-3}
Iron	10×10^{-8}	5.0×10^{-3}
Graphite (carbon)	3500×10^{-8}	-0.5×10^{-3}

27.1 What is the relation between resistance and resistivity?

| The resistance R of a wire of length L and cross-sectional area A is

$$R = \rho \left(\frac{L}{A} \right),$$

where ρ is a constant called the *resistivity* and is a characteristic of the material from which the wire is made. For L in m, A in m^2 , and R in Ω , the units of ρ are $\Omega \cdot \text{m}$.

27.2 How does the resistance of a conductor vary with temperature?

| If a wire has a resistance R_0 at a temperature T_0 , then its resistance R at a temperature T is $R = R_0 + \alpha R_0(T - T_0)$, where α is the *temperature coefficient of resistance* of the material of the wire. Usually α varies with temperature and so a linear relation is applicable only over a small temperature range. The units of α are K^{-1} or $^\circ\text{C}^{-1}$.

A similar relation applies to the variation of resistivity with temperature. If ρ_0 and ρ are the resistivities at T_0 and T respectively, then $\rho = \rho_0 + \alpha \rho_0(T - T_0)$.

Table 27-1 lists the resistivities of a number of conductors for $T_0 = 20^\circ\text{C}$, as well as temperature coefficients of resistance.

27-3 How are current and current density related?

| The rate of flow of electric charge across a given area (within a conductor) is defined as the *electric current* I through that area. Thus,

$$I = \frac{dq}{dt} \quad (\text{A})$$

The *electric current density* \mathbf{J} at a point (within a conductor) is a vector whose direction is the direction of flow of charge at that point and whose magnitude is the current through a *unit area perpendicular to the flow direction* at that point. Thus, the current through an element of area dS , arbitrarily oriented with respect to the flow direction, is given by (see Fig. 27-1) $dI = \mathbf{J} \cdot d\mathbf{S} = J dA$, where $dA = dS \cos \theta$ is the projection of dS perpendicular to the flow direction. The total current through a surface S (e.g., a cross section of the conductor) is then

$$I = \int_S \mathbf{J} \cdot d\mathbf{S} = \int_S J dA$$

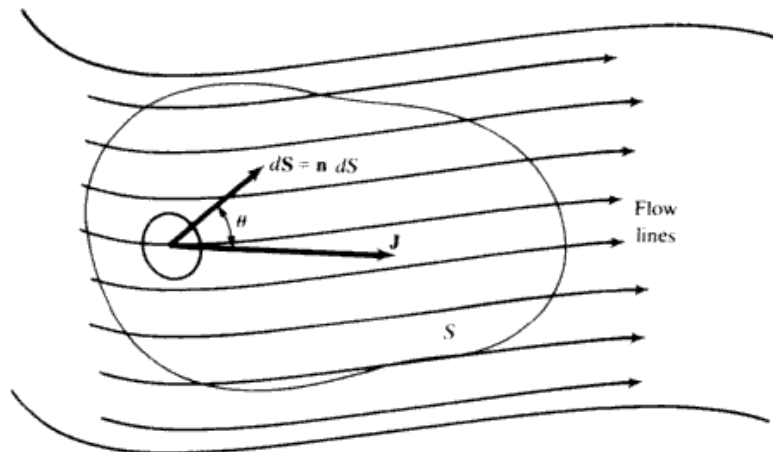

Fig. 27-1

- 27.4** Starting from the standard form of Ohm's law, $V = IR$, find the relation between \mathbf{J} , the current density, and \mathbf{E} , the electric field in a current-carrying conductor.

| We consider a conductor of uniform cross-sectional area A and length L . The resistance $R = \rho(L/A)$, where ρ is the resistivity. The current can be expressed as $I = JA$, and the potential drop across the resistor is related to the average electric field by $V = EL$. Then $V = IR$ becomes $EL = JA[\rho(L/A)]$, or $E = \rho J$. Often one specifies the conductivity, σ , instead of the resistivity, where $\sigma = 1/\rho$. Then $J = \sigma E$. This result can be generalized to an arbitrary conductor in the vector form: $\mathbf{J} = \sigma \mathbf{E}$, which holds at each point in the conductor.

- 27.5** How many electrons per second pass through a section of wire carrying a current of 0.7 A?

| $I = 0.7 \text{ A}$ means 0.7 C/s . Dividing by $e = 1.6 \times 10^{-19} \text{ C}$, the magnitude of charge on a single electron, we get number of electrons per second = $0.7/(1.6 \times 10^{-19}) = 4.4 \times 10^{18}$.

- 27.6** A current of 7.5 A is maintained in a wire for 45 s. In this time (a) how much charge and (b) how many electrons flow through the wire?

| (a) $q = It = (7.5 \text{ A})(45 \text{ s}) = 337.5 \text{ C}$ (b) The number of electrons N is given by

$$N = \frac{q}{e} = \frac{337.5 \text{ C}}{1.6 \times 10^{-19} \text{ C}} = 2.1 \times 10^{21}$$

where $e = 1.6 \times 10^{-19} \text{ C}$ is the charge of an electron.

- 27.7** If 0.6 mol of electrons flow through a wire in 45 min, what are (a) the total charge that passes through the wire, and (b) the magnitude of the current?

| (a) The number N of electrons in 0.6 mol is

$$N = (0.6 \text{ mol})(6.02 \times 10^{23} \text{ electrons/mol}) = 3.6 \times 10^{23} \text{ electrons}$$

$$q = Ne = (3.6 \times 10^{23})(1.6 \times 10^{-19} \text{ C}) = 5.78 \times 10^4 \text{ C}$$

(b) $t = (45 \text{ min})(60 \text{ s/min}) = 2.7 \times 10^3 \text{ s}$

$$I = \frac{q}{t} = \frac{5.78 \times 10^4 \text{ C}}{2.7 \times 10^3 \text{ s}} = 21.4 \text{ A}$$

- 27.8** An electron gun in a TV set shoots out a beam of electrons. The beam current is $10 \mu\text{A}$. How many electrons strike the TV screen each second? How much charge strikes the screen in a minute?

| Let n_e = number of electrons per second. $n_e = I/e = (1.0 \times 10^{-5} \text{ C/s})/(1.6 \times 10^{-19} \text{ C}) = 6.3 \times 10^{13}$ electrons per second. The charge Q striking the screen obeys $|Q| = IT = (10 \mu\text{C/s})(60 \text{ s}) = 600 \mu\text{C}$. Since the charges are electrons, the actual charge is $Q = -600 \mu\text{C}$.

- 27.9** In the Bohr model, the electron of a hydrogen atom moves in a circular orbit of radius $5.3 \times 10^{-11} \text{ m}$ with a speed of $2.2 \times 10^6 \text{ m/s}$. Determine its frequency f and the current I in the orbit.

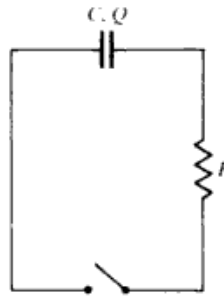

Fig. 27-50

switch is closed the capacitor will discharge through resistance R . Find an expression for $q(t)$, the charge on the capacitor at any time t .

| With the switch closed we must have for the loop equation $q/C + IR = 0$. Since $I =$ rate of discharge, $I = dq/dt$. Then, substituting in the loop equation, we get $dq/dt = -(1/RC)q$, or $dq/q = -(1/RC) dt$. Integrating,

$$\int_Q^q \frac{dq'}{q'} = -\int_0^t \frac{1}{RC} dt' \quad \text{and} \quad \ln \frac{q}{Q} = -\frac{t}{RC}$$

Then $q = Qe^{-t/RC}$. The quantity $RC = \tau$ is called the time constant of the circuit; the larger τ , the longer the discharge time.

- 27.142** In the laboratory, a student charges a $2\text{-}\mu\text{F}$ capacitor by placing it across a 1.5-V battery. While disconnecting it, the student holds its two lead wires in two hands. Assuming that the resistance of the body between the hands is $60\text{ k}\Omega$, what is the time constant of the series circuit composed of the capacitor and the student's body? How long does it take for the charge on the capacitor to drop to $1/e$ of its original value? To $1/100$? (Hint: $\ln 100 \approx 2.30 \log 100$.)

| $\tau = RC = (6 \times 10^4)(2 \times 10^{-6}) = 0.12\text{ s}$. Now $Q = Q_0 \exp(-t/RC) = Q_0 \exp(-t/0.12)$. If $\exp(-t/0.12) = \exp(-1)$, then $t = 0.12\text{ s}$. If $\exp(-t/0.12) = 0.01$, then $\exp(t/0.12) = 100$, or $t/0.12 = \ln 100 \approx 2.30 \log 100 = 4.60$; so $t = 0.55\text{ s}$.

- 27.143** In a certain electronic device, a $10\text{-}\mu\text{F}$ capacitor is charged to 2000 V . When the device is shut off, the capacitor is discharged for safety reasons by a so-called bleeder resistor of $1\text{ M}\Omega$ placed across its terminals. How long does it take for the charge on the capacitor to decrease to 0.01 of its original value?

| We recall that $\ln x \approx 2.30 \log x$; $\tau = RC = 10\text{ s}$. We wish that $Q/Q_0 = \exp(-t/\tau) = 0.01$. From this, $t/10 = 2.30 \log 100$, which gives $t = 46\text{ s}$.

- 27.144** A $400\text{-}\mu\text{F}$ capacitor is connected through a resistor to a battery. Find (a) the resistance R and (b) the emf of the battery \mathcal{E} if the time constant of the circuit is 0.5 s and the maximum charge on the capacitor is 0.024 C .

|
$$R = \frac{\tau}{C} = \frac{0.5\text{ s}}{400 \times 10^{-6}\text{ F}} = 1250\ \Omega \quad \mathcal{E} = \frac{q}{C} = \frac{0.024\text{ C}}{400 \times 10^{-6}\text{ F}} = 60\text{ V}$$

- 27.145** A $50\text{-}\mu\text{F}$ capacitor initially uncharged is connected through a $300\text{-}\Omega$ resistor to a 12-V battery. (a) What is the magnitude of the final charge q_0 on the capacitor? (b) How long after the capacitor is connected to the battery will it be charged to $\frac{1}{2}q_0$? (c) How long will it take for the capacitor to be charged to $0.90q_0$?

| In charging we have $q = q_0(1 - e^{-t/RC})$, with $q_0 = CV$. (a) $q_0 = CV = (50 \times 10^{-6}\text{ F})(12\text{ V}) = 600\ \mu\text{C}$. (b) $\tau = RC = (300\ \Omega)(50 \times 10^{-6}\text{ F}) = 15 \times 10^{-3}\text{ s} = 15\text{ ms}$. From the formula the charge reaches $\frac{1}{2}q_0$ in the time t such that $e^{-t/RC} = \frac{1}{2}$, or $t/(RC) = t/\tau = \ln 2 \approx 0.7$. Thus: $t_{0.5} \approx 0.7\tau = 10.5\text{ ms}$. (c) Similarly, $e^{-t/\tau} = 0.1$ and $t/\tau = \ln 10 \approx 2.3$. Thus $t_{0.9} \approx 2.3\tau = 34.5\text{ ms}$.

- 27.146** A $150\text{-}\mu\text{F}$ capacitor is connected through a $500\text{-}\Omega$ resistor to a 40-V battery. (a) What is the final charge q_0 on a capacitor plate? (b) What is the time constant of the circuit? (c) How long does it take the charge on a capacitor plate to reach $0.8q_0$?

| (a) $q_0 = VC = (40\text{ V})(150 \times 10^{-6}\text{ F}) = 6.0\text{ mC}$. (b) $\tau = RC = (500\ \Omega)(150 \times 10^{-6}\text{ F}) = 75\text{ ms}$. (c) Following the procedure in Prob. 27.145: $-t/\tau = \ln 0.2$ or $t/\tau = \ln 5 \approx 1.6$. Then $t \approx (1.6)(75\text{ ms}) = 120\text{ ms}$.

(c)
$$r = \frac{v^2}{a} = \frac{(3 \times 10^5 \text{ m/s})^2}{1.81 \times 10^{12} \text{ m/s}^2} = \underline{49.7 \text{ mm}}$$

28.13 If it is assumed that a circular path around the earth (radius = 6400 km) can be found upon which the earth's field is horizontal and constant at 0.50 G, how fast must a proton be shot in order to circle the earth? In what direction?

▮ The centripetal force $(mv^2)/r$ is furnished by the force evB_H . Then $v = (eB_H r)/m = [(1.6 \times 10^{-19}) \times (5 \times 10^{-5})(6.4 \times 10^6)]/(1.67 \times 10^{-27}) = \underline{3.1 \times 10^{10} \text{ m/s}}$. It must be shot westward, since the field points north.

28.14 Why is the solution to Prob. 28.13 faulty?

▮ The speed of the proton cannot exceed the speed of light. Evidently, the relativistic equation of motion should have been employed.

28.15 Alpha particles ($m = 6.68 \times 10^{-27} \text{ kg}$, $q = +2e$), accelerated through a potential difference V to 2-keV, enter a magnetic field $B = 0.2 \text{ T}$ perpendicular to their direction of motion. Calculate the radius of their path.

▮ The KE of a particle is conserved in the magnetic field:

$$\frac{1}{2}mv^2 = Vq \quad \text{or} \quad v = \sqrt{\frac{2Vq}{m}}$$

They follow a circular path in which

$$r = \frac{mv}{qB} = \frac{m}{qB} \sqrt{\frac{2Vq}{m}} = \frac{1}{B} \sqrt{\frac{2Vm}{q}} = \frac{1}{0.2 \text{ T}} \sqrt{\frac{2(1000 \text{ V})(6.68 \times 10^{-27} \text{ kg})}{3.2 \times 10^{-19} \text{ C}}} = \underline{32 \text{ mm}}$$

28.16 After being accelerated through a potential difference of 5000 V, a singly charged carbon ion moves in a circle of radius 21 cm in the magnetic field of a mass spectrometer. What is the magnitude of the field?

▮ Following the approach of Prob. 28.15,

$$m_c = (12 \text{ u})(1.66 \times 10^{-27} \text{ kg/u}) = 19.9 \times 10^{-27} \text{ kg} \quad B^2 = \frac{2Vm_c}{r^2q} = \frac{2(5000 \text{ V})(19.9 \times 10^{-27} \text{ kg})}{(0.21 \text{ m})^2(1.6 \times 10^{-19} \text{ C})} \\ \therefore B = \sqrt{2.82 \times 10^{-2} \text{ T}^2} = \underline{0.168 \text{ T}}$$

28.17 A particle with charge q and mass m is shot with kinetic energy K into the region between two plates as shown in Fig. 28-2. If the magnetic field between the plates is B and as shown, how large must B be if the particle is to miss collision with the opposite plate?

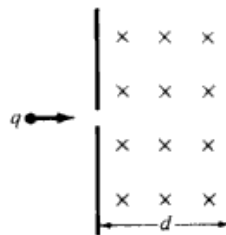

Fig. 28-2

▮ To just miss the opposite plate, the particle must move in a circular path with radius d so from $Bqd = mv$; and using $K = (mv^2)/2$, we have $B = (2mK)^{1/2}/(qd)$.

28.18 A cathode-ray beam (an electron beam; $m = 9.1 \times 10^{-31} \text{ kg}$, $q = -e$) is bent in a circle of radius 2 cm by a uniform field with $B = 4.5 \text{ mT}$. What is the speed of the electrons?

▮ To describe a circle like this, the particle must be moving perpendicular to \mathbf{B} . Then

$$v = \frac{rqB}{m} = \frac{(0.02 \text{ m})(1.6 \times 10^{-19} \text{ C})(4.5 \times 10^{-3} \text{ T})}{9.1 \times 10^{-31} \text{ kg}} = \underline{1.58 \times 10^7 \text{ m/s}}$$

28.19 In Fig. 28-3(a), a proton ($q = +e$, $m = 1.67 \times 10^{-27} \text{ kg}$) is shot with speed $8 \times 10^6 \text{ m/s}$ at an angle of 30° to an x -directed field $B = 0.15 \text{ T}$. Describe the path followed by the proton.

Here,

$$\mathbf{E} = \frac{V}{d} \mathbf{k} = (5 \times 10^4) \mathbf{k} \text{ V/m}$$

and the Lorentz equation gives

$$\begin{aligned} \mathbf{F}_{\text{tot}} &= (3 \times 10^{-6})[(5 \times 10^4) \mathbf{k} + (4 \times 10^4)(0.766 \mathbf{j} + 0.643 \mathbf{k}) \times (1.5 \mathbf{k})] = (3 \times 10^{-6})[(5 \times 10^4) \mathbf{k} + (4 \times 10^4)(0.766)(1.5) \mathbf{i}] \\ &= \underline{0.1397 \mathbf{i} + 0.15 \mathbf{k} \text{ N}} \end{aligned}$$

- 28.28** The value of e/m_e can be obtained by using a specially designed vacuum tube illustrated in Fig. 28-7. It contains a heated filament F and an anode A which is maintained at a positive potential relative to the filament by a battery of known voltage V . Electrons evaporate from the heated filament and are accelerated to the anode, which has a small hole in the center for the electrons to pass through into a region of constant magnetic field B , which points into the paper. The electrons then move in a semicircle of diameter d , hitting the detector as shown. Prove that $e/m_e = 8V/(Bd)^2$.

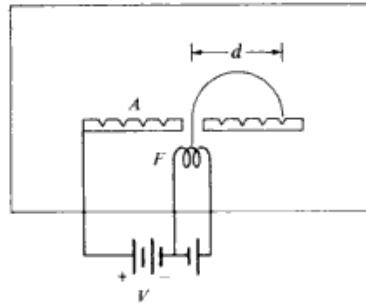

Fig. 28-7

Refer to Fig. 28-7. Newton's second law implies that $(m_e v^2)/r = evB$, where $r = \frac{1}{2}d$ is the radius of the electron's orbit. Solving for the speed, we find that

$$v = \frac{eBr}{m_e} = \frac{eB}{2m_e} d \tag{1}$$

Since the electrons have been accelerated essentially from rest through a potential difference V , each has kinetic energy $\frac{1}{2}m_e v^2 = eV$, so that

$$v^2 = \frac{2eV}{m_e} \tag{2}$$

Combining Eqs. (1) and (2), we obtain

$$\left(\frac{eBd}{2m_e}\right)^2 = \frac{2eV}{m_e}$$

Solving for the charge-to-mass ratio, we have

$$\frac{e}{m_e} = \frac{8V}{B^2 d^2} \tag{3}$$

which was to be shown.

- 28.29** If in a mass spectrograph carbon ions move in a circle of radius $r_C = 9.0$ cm and oxygen ions move in a circle of radius $r_O = 10.4$ cm, what is the mass of an oxygen ion?

We assume that V and B are the same for both ions, so that from Eq. (3) of Prob. 28.28, $m = (B^2 r^2 e)/(2V)$ and

$$\frac{m_O}{m_C} = \frac{r_O^2}{r_C^2} = \frac{(10.4 \text{ cm})^2}{(9.0 \text{ cm})^2} = 1.33$$

That is, the mass of an oxygen ion is 1.33 times the mass of a carbon ion. Since the mass of carbon is defined to be exactly 12 u, the mass of oxygen is $m_O = 1.33m_C = (1.33)(12 \text{ u}) = \underline{16 \text{ u}}$.

over the volume of the wire. The magnetic energy dU_m contained in a cylindrical shell of length l , inner radius r , and outer radius $r + dr$ is

$$dU_m = \epsilon_m dV = \frac{B_w^2(r)}{2\mu_0} 2\pi r l dr = \frac{\mu_0 i^2 l}{4\pi a^4} r^3 dr$$

Hence the magnetic energy per unit length contained in the wire is

$$\frac{U_m}{l} = \frac{1}{l} \int dU_m = \frac{\mu_0 i^2}{4\pi a^4} \int_0^a r^3 dr = \frac{\mu_0 i^2}{4\pi a^4} \left(\frac{r^4}{4} \Big|_0^a \right) = \frac{\mu_0 i^2}{16\pi}$$

29.33 The external magnetic field of a spherical object of radius R , surrounded by vacuum and carrying an (idealized) central point magnetic dipole, contains magnetic energy $U = (\pi/2)[(B_p^2 R^3)/(2\mu_0)]$. The quantity B_p is the maximum magnetic field strength at the surface of the object—that is, the value of B at the object's magnetic poles.

(a) The earth's external magnetic field is not that of a pure centered point dipole, nor is the earth surrounded by a perfect vacuum. Nevertheless, a reasonable estimate of the energy content U in the external field is $U \approx (B_p^2 R^3)/(2\mu_0)$. Evaluate this, using $B_p = 6.0 \times 10^{-5}$ T and $R = 6.4 \times 10^6$ m.

(b) Compare the energy U to the total annual usage of electric energy in the United States. It was 1.7×10^{12} kW · h in 1972.

▮ (a) With $B_p = 6.0 \times 10^{-5}$ T, $R = 6.4 \times 10^6$ m, and $\mu_0 = 4\pi \times 10^{-7}$ N/A², we have

$$U \approx \frac{B_p^2 R^3}{2\mu_0} = \frac{(6.0 \times 10^{-5})^2 (6.4 \times 10^6)^3}{2(4\pi \times 10^{-7})} = 3.8 \times 10^{17} \text{ J}$$

(b) The electric energy usage in the United States for 1972 was

$$E = 1.7 \times 10^{12} \text{ kW} \cdot \text{h} = (1.7 \times 10^{12})(10^3 \text{ J/s})(3600 \text{ s}) = 6.1 \times 10^{18} \text{ J}$$

29.2 MAGNETS; POLE STRENGTH

29.34 Describe how the torque on a bar magnet placed in a magnetic field can be expressed in terms of pole strength.

▮ When a bar magnet is placed with its axis perpendicular to a uniform magnetic field of intensity \mathbf{B} , it experiences a torque $\tau = Bm = Bpl$, where m is the magnetic moment, l is the length of the magnet, and p is the pole strength of the magnet. Fundamentally, this torque arises from the interaction between the magnetic induction and the infinitesimal current loops associated with the orbits and spin of certain of the magnet's electrons. An alternative approach, frequently convenient, is to endow the magnet with a pair of equal and oppositely signed *poles* at its two ends, and to attribute the torque to the equal and opposite forces exerted by the field B on these poles. When a pole of strength p is placed in a magnetic field of intensity B , the pole experiences a force $F = Bp$. In general, $\tau = mB \sin \theta$, where $\theta =$ angle between \mathbf{m} and \mathbf{B} .

29.35 An iron bar magnet of length 10 cm and cross section 1.0 cm² has a magnetization of 10² A/m. Calculate the magnet's magnetic pole strength.

▮ The magnetic moment of a bar magnet of length $2d$ has magnitude $m = 2|p|d$, where $|p|$ is the pole strength. In terms of the magnetization \mathbf{M} , the magnetic moment of the bar magnet is $\mathbf{m} = \mathbf{M}(2ad)$, where a is the cross-sectional area. Hence $|p| = m/2d = aM$. With $a = 1.0 \text{ cm}^2 = 1.00 \times 10^{-4} \text{ m}^2$ and $M = 1.00 \times 10^2 \text{ A/m}$, we obtain $|p| = (1.00 \times 10^{-4})(1.00 \times 10^2) = 1.00 \times 10^{-2} \text{ A} \cdot \text{m}$.

29.36 The field of a bar magnet can be considered to be caused by a surface current flowing on the surface of the magnet. If a bar magnet is to act like a solenoid whose interior field is 0.3 T, how large a surface current must flow on each centimeter length of the bar?

▮ In Fig. 29-7 take segment length $l = 1.0$ cm. Since B is axial and ~ 0 outside the solenoid, the circuital law yields Bl equal to $\mu_0 I_m$, so $I_m = 0.3(10^{-2})/(4\pi \times 10^{-7}) = 2390 \text{ A/m} = 23.9 \text{ A/cm}$.

29.37 What is the relationship between the magnetization (or Amperean) surface current I_m in a long bar magnet and the pole strength?

▮ From Prob. 29.35, $p = aM$. Applying the circuital law for \mathbf{B} to the magnet (Fig. 29.7), and noting that $\mathbf{B} = \mu_0(\mathbf{H} + \mathbf{M})$ and that \mathbf{H} cannot contribute since there are no true currents, we get $Ml = I_m$: Then $p = aI_m/l$.

36.46 Reconsider Prob. 36.40 when the source emits a continuous mixture of wavelengths. The *resolving power*, at wavelength λ , of the grating is defined as $R = \lambda/\delta$, where δ is the smallest wavelength difference for which the spectral lines $\lambda - \frac{1}{2}\delta$ and $\lambda + \frac{1}{2}\delta$ are resolvable. Find R_m , the resolving power in the m th order.

▮ According to *Rayleigh's criterion*, two peaks are just resolvable when their angular separation is half the angular width of either peak. This minimal separation is given by (1) of Prob. 36.40 as

$$(\Delta\theta)_{\min} = \frac{\lambda}{Nd \cos \theta} \quad \text{or} \quad d \cos \theta (\Delta\theta)_{\min} = \frac{\lambda}{N}$$

Differentiation of the grating equation, $d \sin \theta = m\lambda$, gives

$$d \cos \theta \Delta\theta = m \Delta\lambda \quad \text{whence} \quad d \cos \theta (\Delta\theta)_{\min} = m\delta$$

Comparing the two expressions for $d \cos \theta (\Delta\theta)_{\min}$ gives $R_m = mN$.

Note that the resolving power is the same for all wavelengths.

36.47 A transmission grating is used with light incident normal to its plane. The width of each slit is one-third the spacing between slits. By considering single-slit diffraction, show that the third-order ($j = 3$) multislit diffraction maxima are missing from the diffraction pattern of the grating.

▮ As discussed in Prob. 36.35, the intensity profile in the overall diffraction pattern due to N slits of finite width is the *product* of the “ideal” N -slit intensity profile and the single-slit profile. According to Eq. (1) of Prob. 36.35, the j th maximum of the ideal N -slit profile occurs at an angle θ_j such that

$$\sin \theta_j = \frac{j\lambda}{d} \tag{1}$$

where d is the slit spacing. However, if each slit has width $w = d/3$, then Fig. 36-14b [or (1) of Prob. 36.33] implies that the single slit profile has zeros at angles given by

$$\sin \theta_m = \frac{m\lambda}{w} = \frac{3m\lambda}{d} \tag{2}$$

for $m = 0, \pm 1, \pm 2, \pm 3$. Equations (1) and (2) show that the *overall* profile must have a zero at every third maximum of the ideal N -slit pattern. In particular, the third-order maxima ($j = \pm 3$) are removed by the first minima ($m = \pm 1$) of the single-slit pattern.

36.48 A beam of light of wavelength λ falls on a diffraction grating of line spacing D at angle of incidence ϕ measured from the normal to the plane of the grating. Show that the maxima in the diffraction pattern occur at angles θ which are determined by the equation $j\lambda = D (\sin \theta - \sin \phi)$, where $j = 0, \pm 1, \pm 2, \pm 3, \dots$

▮ The situation is indicated in Fig. 36-17. The initial beam direction is assumed to be perpendicular to the

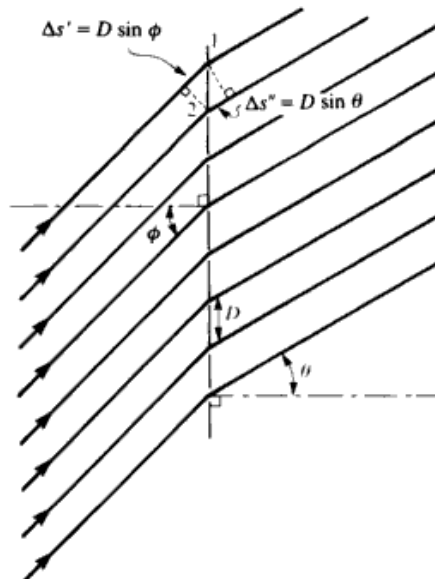

Fig. 36-17

now polarized at 30° to the axis of the analyzer, so the intensity of the light passing through the analyzer is $I' = I \cos^2 \theta = 0.75I_0 \cos^2 30^\circ = 0.563I_0$.

- 36.70** Polarized light of intensity I_0 is incident on a pair of Polaroid sheets. Let θ_1 and θ_2 be the angles between the incident amplitude and the axes of the first and second sheets, respectively. Show that the intensity of the transmitted light is $I = I_0 \cos^2 \theta_1 \cos^2 (\theta_1 - \theta_2)$.

| The intensity of the light after passing through the first polarizer is $I = I_0 \cos^2 \theta_1$. This light is polarized in the direction of the axis of the first sheet, and so its axis makes the angle $\theta_2 - \theta_1$ with the axis of the second sheet (see Fig. 36-25). Consequently, the intensity of the light after passing through the second polarizer is

$$I' = I \cos^2 (\theta_2 - \theta_1) = I_0 \cos^2 \theta_1 \cos^2 (\theta_2 - \theta_1)$$

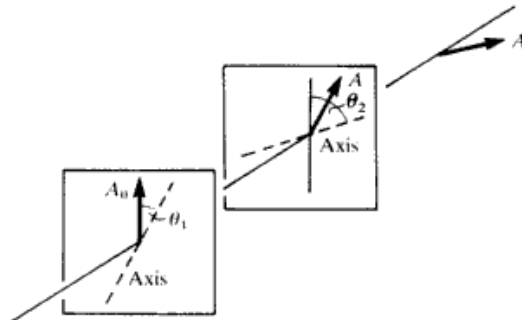

Fig. 36-25

- 36.71** Two Polaroids are aligned with their axes of transmission making an angle of 45° . They are followed by a third Polaroid whose axis of transmission makes an angle of 90° with the first Polaroid. If all three are ideal, what fraction of the maximum possible light (if all Polaroids were at the same angle) passes through all three?

| The reduction factor for either of the last two Polaroids is $\cos^2 45^\circ = 1/2$; so the overall factor is $(\frac{1}{2})^2 = \frac{1}{4}$.

- 36.72** The axes of a polarizer and an analyzer are oriented at right angles to each other. A third Polaroid sheet is placed between them with its axis at 45° to the axes of the polarizer and analyzer. (a) If unpolarized light of intensity I_0 is incident on this system, what is the intensity of the transmitted light? (b) What is the intensity of the transmitted light when the middle Polaroid sheet is removed?

| (a) The light that passes through the polarizer has an intensity of $\frac{1}{2}I_0$ and is polarized at 45° to the middle sheet. Thus the light that passes through the middle sheet has the intensity $I = \frac{1}{2}I_0 \cos^2 45^\circ = 0.25I_0$ and is polarized 45° to the axis of the analyzer. Thus the intensity of the light passing through the analyzer is $I' = I \cos^2 45^\circ = 0.125I_0$. (b) If the middle Polaroid sheet is removed, we have a crossed polarizer-analyzer and no light gets through. (Compare Prob. 36.68.)

- 36.73** Four perfect polarizing plates are stacked so that the axis of each is turned 30° clockwise with respect to the preceding plate; the last plate is crossed with the first. How much of the intensity of an incident unpolarized beam of light is transmitted by the stack?

| The first plate transmits one half of the incident intensity. Each succeeding plate makes a vector resolution at angle 30° , transmitting the fraction $\cos 30^\circ$ of the amplitude, or $\cos^2 30^\circ = \frac{3}{4}$ of the intensity, leaving the preceding plate. The fraction of the initial intensity transmitted by the stack is then $\frac{1}{2}(\frac{3}{4})^3 = 0.211$.

- 36.74** A quarter-wave plate is made from a material whose indices of refraction for light of free-space wavelength $\lambda_0 = 589 \text{ nm}$ are $n_\perp = 1.732$ and $n_\parallel = 1.456$. What is the minimum necessary thickness of the plate for this wavelength?

| The optical path length (Prob. 34.53) of the ordinary wave in a plate of thickness l is $n_\perp l$ and the optical path length of the extraordinary ray is $n_\parallel l$. Since the two rays must emerge from the plate with a 90° phase difference, the optical paths must differ by $(k + \frac{1}{4})\lambda_0$, $k = 0, 1, 2, \dots$. The minimum thickness thus satisfies

$$\frac{\lambda_0}{4} = l(n_\perp - n_\parallel) \quad \text{or} \quad l = \frac{\lambda_0}{4(n_\perp - n_\parallel)} = \frac{589 \text{ nm}}{4(1.732 - 1.456)} = 534 \text{ nm}$$

Equations (11) and (12) agree with Eqs. (5) and (8) of Prob. 37.1; the inversion of the y' and z' equations is trivial.

- 37.3** For the situation of Prob. 37.1, suppose that at the instant origin O' coincides with O (at $t = t' = 0$), a flashbulb is exploded at this common origin. According to observers in \mathcal{L} , a spherical wavefront expands outward from O at speed c . Show that, even though \mathcal{L}' is moving relative to \mathcal{L} with velocity v , observers in \mathcal{L}' note an exactly similar wavefront expanding outward from O' .

▮ The equation of the wavefront in \mathcal{L} is

$$x^2 + y^2 + z^2 = c^2 t^2 \quad (1)$$

The Lorentz transformation of (1) is (Eqs. (5) to (8), Prob. 37.1)

$$\left[\frac{x' + vt'}{\sqrt{1 - (v^2/c^2)}} \right]^2 + (y')^2 + (z')^2 = c^2 \left[\frac{t' + (vx'/c^2)}{\sqrt{1 - (v^2/c^2)}} \right]^2$$

which reduces to

$$(x')^2 + (y')^2 + (z')^2 = c^2 (t')^2 \quad (2)$$

Equation (2) represents a spherical wavefront expanding outward from O' at speed c .

Actually, the reasoning goes the other way round. The \mathcal{L} and \mathcal{L}' observers must see exactly the same kind of wave, by the postulates of special relativity. This (almost) forces the relations between the coordinates in the two frames to have a particular form—that of the Lorentz transformations. See Prob. 37.5.

- 37.4** When inertial reference frames \mathcal{L} and \mathcal{L}' coincide, let a flash of light be produced at the common origin. Each observer is justified in considering himself at the center of an expanding sphere of light. Experiment has revealed that each obtains the same value c for the speed of light. The galilean transformation, $x' = x - vt$, does not give this result. Therefore try a modification, $x' = \gamma(x - vt)$, where γ is to be determined. The principle of equivalence requires that this equation hold for the inverse transformation, $x = \gamma(x' - v't')$ = $\gamma(x' + vt')$. In this equation, we use the assertion that $v' = -v$. But for generality, the possibility has been allowed that t' may be different from t .

If x and x' are the intersections of the sphere with the axis at times t and t' , respectively: (a) To what is x'/t' equal? (b) To what is x/t equal? (c) Use the results of parts (a) and (b) to eliminate x and x' in the transformation equations and thus to determine γ .

▮ We note that the problem statement includes the tacit assumption that $\gamma' = \gamma$ when $v' = -v$.

(a) At time t' , the light sphere observed by \mathcal{L}' intersects the positive x' axis at a coordinate $x' = ct'$. Therefore $x'/t' = c$. (b) At time t , the light sphere observed by \mathcal{L} intersects the positive x axis at a coordinate $x = ct$. Therefore $x/t = c$. (c) Since the equations obtained in parts (a) and (b) refer to the same point event, we use $x' = ct'$ and $x = ct$ in our equations to get

$$ct' = \gamma(ct - vt) \quad (1)$$

and

$$ct = \gamma(ct' + vt') \quad (2)$$

Multiplying Eqs. (1) and (2) we have

$$c^2 t t' = \gamma^2 (c^2 - v^2) t t'$$

Solving this for γ , we find

$$\gamma = \frac{1}{\sqrt{1 - (v^2/c^2)}} \quad (3)$$

- 37.5** Continuing with the results of Prob. 37.4, use the relation for γ , express t' in terms of t and x .

▮ When Eq. (3) is used in the transformation equations (Prob. 37.4), we obtain

$$x' = \frac{1}{\sqrt{1 - (v^2/c^2)}} (x - vt) \quad (4)$$

and

$$x = \frac{1}{\sqrt{1 - (v^2/c^2)}} (x' + vt') \quad (5)$$

These equations relate arbitrary event-coordinate observations of observers O and O' . Using Eq. (4) to

eliminate x' from Eq. (5), we find that

$$x = \frac{(x - vt')}{1 - (v^2/c^2)} + \frac{vt'}{\sqrt{1 - (v^2/c^2)}}$$

Solving this for t' , we find (after some algebra) that

$$t' = \frac{1}{\sqrt{1 - (v^2/c^2)}} \left(t - \frac{vx}{c^2} \right)$$

which is the standard Lorentz transformation equation for t' .

- 37.6** As measured by \mathcal{L} a flashbulb goes off at $x = 100$ km, $y = 10$ km, $z = 1$ km at $t = 0.5$ ms. What are the coordinates x' , y' , z' , and t' of this event as determined by a second observer, \mathcal{L}' , moving relative to \mathcal{L} at $-0.8c$ along the common xx' axis?

▮ From the Lorentz transformations,

$$\begin{aligned} x' &= \frac{x - vt}{\sqrt{1 - (v^2/c^2)}} = \frac{100 \text{ km} - (-0.8 \times 3 \times 10^5 \text{ km/s})(5 \times 10^{-4} \text{ s})}{\sqrt{1 - 0.8^2}} = \underline{367 \text{ km}} \\ t' &= \frac{t - (v/c^2)x}{\sqrt{1 - (v^2/c^2)}} = \frac{5 \times 10^{-4} \text{ s} - [(-0.8)(100 \text{ km})]/(3 \times 10^5 \text{ km/s})}{\sqrt{1 - (0.8)^2}} = \underline{1.28 \text{ ms.}} \\ y' &= y = \underline{10 \text{ km}} \quad z' = z = \underline{1 \text{ km}} \end{aligned}$$

- 37.7** At time $t' = 0.4$ ms, as measured in \mathcal{L}' , a particle is at the point $x' = 10$ m, $y' = 4$ m, $z' = 6$ m. (Note that this constitutes an event.) Compute the corresponding values of x , y , z , t , as measured in \mathcal{L} , for (a) $v = +500$ m/s, (b) $v = -500$ m/s, and (c) $v = 2 \times 10^8$ m/s.

▮ From the inverse Lorentz transformation, Prob. 37.1,

$$\begin{aligned} \text{(a)} \quad x &= \frac{10 + (500)(4 \times 10^{-4})}{\sqrt{1 - (500^2/c^2)}} \approx 10 + (500)(4 \times 10^{-4}) = \underline{10.2 \text{ m}} \quad y = \underline{4 \text{ m}} \quad z = \underline{6 \text{ m}} \\ t &= \frac{(4 \times 10^{-4}) + [(500)(10)]/c^2}{\sqrt{1 - (500^2/c^2)}} \approx 4 \times 10^{-4} \text{ s} \\ \text{(b)} \quad x &= \frac{10 - (500)(4 \times 10^{-4})}{\sqrt{1 - (500^2/c^2)}} \approx 10 - (500)(4 \times 10^{-4}) = \underline{9.8 \text{ m}} \quad y = \underline{4 \text{ m}} \quad z = \underline{6 \text{ m}} \\ t &= \frac{(4 \times 10^{-4}) - [(500)(10)]/c^2}{\sqrt{1 - (500^2/c^2)}} \approx 4 \times 10^{-4} \text{ s} \\ \text{(c)} \quad x &= \frac{10 + (2 \times 10^8)(4 \times 10^{-4})}{\sqrt{1 - (2/2.997925)^2}} = \frac{8.001 \times 10^4}{0.744943} = \underline{107.4 \text{ km}} \quad y = \underline{4 \text{ m}} \quad z = \underline{6 \text{ m}} \\ t &= \frac{(4 \times 10^{-4}) + [(2 \times 10^8)(10)]/c^2}{\sqrt{1 - (v^2/c^2)}} = \underline{5.37 \times 10^{-4} \text{ s}} \end{aligned}$$

- 37.8** At $t = 1$ ms (in \mathcal{L}), an explosion occurs at $x = 5$ km. What is the time of the event for the \mathcal{L}' observer, if for him it occurs at $x' = 35.354$ km?

▮ From the Lorentz transformation for x' ,

$$35.354 \times 10^3 = \frac{(5 \times 10^3) - v(10^{-3})}{\sqrt{1 - (v^2/c^2)}} \quad \text{or} \quad v = -3 \times 10^7 \text{ m/s}$$

Then, from the Lorentz transformation for t' ,

$$t' = \frac{10^{-3} + [(3 \times 10^7)(5 \times 10^3)]/c^2}{\sqrt{1 - (v^2/c^2)}} = \underline{1.0067 \text{ ms.}}$$

- 37.9** A spaceship of (rest) length 100 m takes 4 μ s to pass an observer on earth. What is its velocity relative to the earth?

▮ The observer measures the length of the spaceship to be $l = 100\sqrt{1 - (v^2/c^2)}$ (m), where v is the velocity of

■ The rest mass lost in the formation of a deuteron is

$$(m_p + m_n) - m_d = (1.67261 + 1.67492 - 3.34357) \times 10^{-27} = 3.96 \times 10^{-30} \text{ kg}$$

which is equivalent to a rest-energy loss

$$\Delta E_0 = 3.96 \times 10^{-30} c^2 = 3.56 \times 10^{-13} \text{ J} = 2.22 \text{ MeV}$$

Hence, by energy conservation, the surroundings must gain exactly 2.22 MeV of energy. This same amount of energy, the *binding energy* of the deuteron, would have to be supplied to the deuteron to tear it apart into an infinitely separated proton and neutron.

37.51 Determine the mass and speed of an electron having kinetic energy of 100 keV (1.6×10^{-14} J).

■ The kinetic energy is $K = mc^2 - m_0c^2$, or $1.6 \times 10^{-14} \text{ J} = (m - m_0)(3 \times 10^8 \text{ m/s})^2$, and $m - m_0 = 1.78 \times 10^{-31} \text{ kg}$. In Prob. 37.49 we are given $m_0 = 9.11 \times 10^{-31} \text{ kg}$; so $m = (9.11 + 1.78) \times 10^{-31} \text{ kg} = \underline{1.089 \times 10^{-30} \text{ kg}}$. To get velocity we note that $m = m_0/\sqrt{1 - (v^2/c^2)}$, or $1 - (v^2/c^2) = (m_0/m)^2 = 0.700$. Then $v/c = 0.548$, and $v = \underline{1.64 \times 10^8 \text{ m/s}}$.

37.52 Find the speed that a proton must be given if its mass is to be twice its rest mass of $1.67 \times 10^{-27} \text{ kg}$. What energy must be given the proton to achieve this speed?

■ Use the mass-increase formula.

$$m = m_0 / \sqrt{1 - \frac{v^2}{c^2}} \quad 2m_0 = m_0 / \sqrt{1 - \frac{v^2}{c^2}} \quad 4\left(1 - \frac{v^2}{c^2}\right) = 1; \quad \frac{v^2}{c^2} = \frac{3}{4} \quad v = \underline{0.866c}$$

$$\Delta W = (m - m_0)c^2 = (2m_0 - m_0)c^2 = (1.67 \times 10^{-27} \text{ kg})(3 \times 10^8 \text{ m/s})^2 = 1.50 \times 10^{-10} \text{ J} = \underline{938 \text{ MeV}}$$

37.53 How much energy must be given to an electron to accelerate it to $0.95c$?

■ Use the mass-increase formula.

$$m = \frac{m_0}{\sqrt{1 - (v^2/c^2)}} = \frac{9.1 \times 10^{-31} \text{ kg}}{\sqrt{1 - 0.95^2}} = 29.1 \times 10^{-31} \text{ kg}$$

$$\Delta W = (m - m_0)c^2 = [(29.1 - 9.1)(10^{-31})](9 \times 10^{16}) = 1.8 \times 10^{-13} \text{ J} = \underline{1.125 \text{ MeV}}$$

37.54 A 2-kg object is lifted from the floor to a tabletop 30 cm above the floor. By how much did the mass of the object increase because of its increased PE?

■ We use $\Delta E = (\Delta m)c^2$, with $\Delta E = mgh$. Therefore

$$\Delta m = \frac{\Delta E}{c^2} = \frac{mgh}{c^2} = \frac{(2 \text{ kg})(9.8 \text{ m/s}^2)(0.3 \text{ m})}{(3 \times 10^8 \text{ m/s})^2} = \underline{6.5 \times 10^{-17} \text{ kg}}$$

37.55 The rest mass of a proton is $m_0 = 1.672614 \times 10^{-27} \text{ kg}$. Its laboratory speed after having fallen through a high difference in potential, ΔV , is $u = 2 \times 10^8 \text{ m/s}$. (a) Evaluate ΔV . (b) Find the total energy of the proton.

■ (a) The kinetic energy of the proton is

$$K = (m - m_0)c^2 = \left[\frac{1}{\sqrt{1 - (u^2/c^2)}} - 1 \right] m_0c^2 = e \Delta V$$

from which
$$\Delta V = \frac{[(1/0.744943) - 1](1.672614 \times 10^{-27})(2.997925 \times 10^8)^2}{1.602 \times 10^{-19}} = \underline{321 \text{ MV}}$$

(b) The rest energy of the proton is $m_0c^2 = 938.3 \text{ MeV}$, and so the total energy is

$$E = 938.3 + 321 = \underline{1259.3 \text{ MeV}}$$

37.56 Show that $\text{KE} = (m - m_0)c^2$ reduces to $\text{KE} = \frac{1}{2}m_0v^2$ when v is very much smaller than c .

■
$$\text{KE} = (m - m_0)c^2 = \left(\frac{m_0}{\sqrt{1 - (v/c)^2}} - m_0 \right) c^2 = m_0c^2 [(1 - v^2/c^2)^{-1/2} - 1]$$

Let $b = -v^2/c^2$ and expand $(1 + b)^{-1/2}$ by the binomial theorem. Then

$$(1 + b)^{-1/2} = 1 + (-\frac{1}{2})b + \frac{(-\frac{1}{2})(-\frac{3}{2})}{2!}b^2 + \dots = 1 + \frac{1}{2}\frac{v^2}{c^2} + \frac{3}{8}\frac{v^4}{c^4} + \dots$$

Thus the desired relation is

$$E^2 = E_0^2 + (pc)^2 \quad (1)$$

Because of the form of (1) momenta are often specified in MeV/c, on the atomic level, where energies are given in eV or MeV. (See Prob. 37.63.) (b) The total energy of the electron is its rest energy, 0.511 MeV, plus its kinetic energy, 1 MeV. Then (1) gives $1.511^2 = 0.511^2 + (pc)^2$, from which $pc = 1.42$ MeV, or $p = 1.42$ MeV/c.

37.63 Compute the conversion factor between the ordinary units of momentum and MeV/c.

▮ $1 \text{ MeV}/c = (1.6 \times 10^{-13} \text{ J}) / (3 \times 10^8 \text{ m/s}) = 5.33 \times 10^{-22} \text{ kg} \cdot \text{m/s}.$

37.64 Show that rest mass is not conserved in a symmetrical, perfectly inelastic collision.

▮ Let two identical bodies, each with rest mass m_0 , approach each other at equal speeds u , collide, and stick together. By momentum conservation, the conglomerate body must be at rest, with energy M_0c^2 . The initial energy of the system was $2[m_0c^2/\sqrt{1 - (u^2/c^2)}]$. Hence,

$$\frac{2m_0c^2}{\sqrt{1 - (u^2/c^2)}} = M_0c^2 \quad \text{or} \quad M_0 = \frac{2m_0}{\sqrt{1 - (u^2/c^2)}}$$

It is seen that the final rest mass, M_0 , exceeds the initial rest mass, $2m_0$.

37.65 In newtonian mechanics the relation $dE/dt = \mathbf{F} \cdot \mathbf{v}$ is valid, where E is the total energy of a particle that is moving with velocity \mathbf{v} and is acted on by a net force \mathbf{F} . Show that this relation is also valid in relativistic mechanics. (Assume that Newton's second law is valid under special relativity.)

▮ As shown in Prob. 37.62, the particle's instantaneous momentum $\mathbf{p}(t)$ and instantaneous energy $E(t)$ are related by

$$E^2 = c^2 \mathbf{p} \cdot \mathbf{p} + (m_0c^2)^2 \quad (1)$$

Differentiating Eq. (1) with respect to time, we find that

$$2E \frac{dE}{dt} = 2c^2 \mathbf{p} \cdot \frac{d\mathbf{p}}{dt}$$

or

$$\frac{dE}{dt} = \frac{c^2 \mathbf{p} \cdot d\mathbf{p}}{E dt} \quad (2)$$

But $\mathbf{p} = m\mathbf{v} = \gamma m_0 \mathbf{v}$ and $E = mc^2 = \gamma m_0 c^2$, so $(c^2 \mathbf{p})/E = \mathbf{v}$. Using this in Eq. (2), we obtain

$$\frac{dE}{dt} = \frac{d\mathbf{p}}{dt} \cdot \mathbf{v} = \mathbf{F} \cdot \mathbf{v} \quad (3)$$

since $\mathbf{F} = d\mathbf{p}/dt$.

37.66 Show that the components of the velocity of a particle of energy E and momentum \mathbf{p} are given by

$$v_x = \frac{\partial E}{\partial p_x} \quad v_y = \frac{\partial E}{\partial p_y} \quad v_z = \frac{\partial E}{\partial p_z}$$

These relations apply in both the relativistic and newtonian domains.

▮ The energy is given in terms of the momentum by

$$E = \sqrt{c^2 p^2 + (m_0c^2)^2} = \sqrt{c^2(p_x^2 + p_y^2 + p_z^2) + (m_0c^2)^2}$$

Differentiating with respect to p_x , we find that

$$\frac{\partial E}{\partial p_x} = \frac{1}{2} \frac{2c^2 p_x}{\sqrt{c^2(p_x^2 + p_y^2 + p_z^2) + (m_0c^2)^2}} = \frac{c^2 p_x}{E} = \frac{c^2 \gamma m_0 v_x}{\gamma m_0 c^2} = v_x$$

The proofs for the y and z components follow the same procedures.

Since the newtonian result is just the low-velocity limit of the relativistic result, the above relations hold in the newtonian domain. They may also be easily derived from $E = p^2/(2m_0) = p_x^2/(2m_0) + p_y^2/(2m_0) + p_z^2/(2m_0)$. Then $\partial E/\partial p_x = p_x/m_0 = v_x$, etc.

so the magnetic field magnitude at distance r'' is

$$B'' = \frac{\mu_0 i''}{2\pi r''} = \frac{\mu_0 i''}{2\pi r} = \frac{(2 \times 10^{-7})(1.06 \times 10^{-4})}{1.00 \times 10^{-2}} = \underline{2.120 \text{ nT}}$$

Finally, $F_m = ev_p'' B'' = (1.6 \times 10^{-19})(5.294 \times 10^7)(2.12 \times 10^{-9}) = 1.79 \times 10^{-20} \text{ N}$ toward the beam.

- 37.70** A large cyclotron is designed to accelerate deuterons to 450 MeV of kinetic energy. This means that their speed will become a substantial fraction of c . Hence their mass will become substantially larger than the rest mass. If the magnetic field is everywhere of the same value, this requires that the frequency of the oscillating potential difference applied between the Dees be decreased during the acceleration of a group of deuterons. What is the ratio of the final to the initial frequency? The rest mass of a deuteron is $3.3 \times 10^{-27} \text{ kg}$.

▮ For a particle circling at relativistic speed in a magnetic field, the relativistic force, $\mathbf{F} = d\mathbf{p}/dt$, is still correctly given by the Lorentz formula:

$$\mathbf{F} = \frac{d\mathbf{p}}{dt} = q\mathbf{v} \times \mathbf{B} \quad (1)$$

The momentum is given by $\mathbf{p} = \gamma m_0 \mathbf{v}$, where $\gamma = [1 - (v^2/c^2)]^{-1/2}$. If the particle is circling with angular velocity ω_c , we have, since the magnitude of \mathbf{p} is constant,

$$\frac{d\mathbf{p}}{dt} = \omega_c \times \mathbf{p} = \gamma m_0 (\omega_c \times \mathbf{v}) \quad (2)$$

Equations (1) and (2) imply that, in magnitude,

$$\omega_c = \frac{qB}{\gamma m_0} = \frac{qB}{m} \quad (3)$$

where $m = \gamma m_0$ is the relativistic mass. Since the deuterons are initially nonrelativistic, Eq. (3) implies that

$$\frac{\omega_{cf}}{\omega_{ci}} = \frac{\gamma_i}{\gamma_f} = \frac{1}{\gamma_f} \quad (4)$$

In terms of the final kinetic energy K_f , we have

$$\gamma_f = \frac{K_f + m_0 c^2}{m_0 c^2} \quad (5)$$

The rest energy of the deuteron is

$$m_0 c^2 = \frac{(3.3 \times 10^{-27} \text{ kg})(3.00 \times 10^8 \text{ m/s})^2}{1.60 \times 10^{-13} \text{ J/MeV}} = 1.86 \times 10^3 \text{ MeV}$$

Then with $K_f = 450 \text{ MeV}$, Eqs. (4) and (5) yield

$$\frac{\omega_{cf}}{\omega_{ci}} = \frac{1}{\gamma_f} = \frac{1860}{450 + 1860} = \underline{0.81}$$

- 38.9** A desk lamp illuminates a desk top with violet light of wavelength 412 nm. The amplitude of this electromagnetic wave is 63.2 V/m. Find the number N of photons striking the desk per second per unit area, assuming that the illumination is normal.

▮ From $\mathcal{E} = (hc)/\lambda$ and the energy density formula, $(\epsilon_0 E_0^2)/2$, for a wave with electric field amplitude E_0 (Prob. 33.64)

$$N = \frac{\lambda \epsilon_0 E_0^2}{2h} = \frac{(412 \times 10^{-9})(8.85 \times 10^{-12})(63.2^2)}{2(6.63 \times 10^{-34})} = 1.10 \times 10^{19} \text{ photons/s} \cdot \text{m}^2$$

- 38.10** A sensor is exposed for 0.1 s to a 200-W lamp 10 m away. The sensor has an opening that is 20 mm in diameter. How many photons enter the sensor if the wavelength of the light is 600 nm? Assume that all the energy of the lamp is given off as light.

▮ The energy of a photon of the light is

$$E = \frac{hc}{\lambda} = \frac{(6.63 \times 10^{-34})(3 \times 10^8)}{600 \times 10^{-9}} = 3.3 \times 10^{-19} \text{ J}$$

The lamp uses 200 W of power. The number of photons emitted per second is therefore

$$n = \frac{200}{3.3 \times 10^{-19}} = 6.1 \times 10^{20} \text{ photons/s}$$

Since the radiation is spherically symmetrical, the number of photons entering the sensor per second is n multiplied by the ratio of the aperture area to the area of a sphere of radius 10 m:

$$(6.1 \times 10^{20}) \frac{\pi(0.010^2)}{4\pi(10^2)} = 1.53 \times 10^{14} \text{ photons/s}$$

and the number of photons that enter the sensor in 0.1 s is $(0.1)(1.53 \times 10^{14}) = 1.53 \times 10^{13}$.

- 38.11** What is the momentum-energy relation for photons?

▮ From Prob. 37.62, $\mathcal{E}^2 = (pc)^2 + (m_0c^2)^2$. But a photon has zero rest mass, so $\mathcal{E} = pc$.

- 38.12** What is the momentum of a single photon of red light ($\nu = 400 \times 10^{12}$ Hz) moving through free space?

▮ The momentum is given by $p = h/\lambda = (h\nu)/c$. Hence

$$p = \frac{(6.6 \times 10^{-34})(400 \times 10^{12})}{3 \times 10^8} = 8.8 \times 10^{-28} \text{ kg} \cdot \text{m/s}.$$

- 38.13** What wavelength must electromagnetic radiation have if a photon in the beam is to have the same momentum as an electron moving with a speed 2×10^5 m/s?

▮ The requirement is that $(mv)_{\text{electron}} = (h/\lambda)_{\text{photon}}$. From this,

$$\lambda = \frac{h}{mv} = \frac{6.63 \times 10^{-34} \text{ J} \cdot \text{s}}{(9.1 \times 10^{-31} \text{ kg})(2 \times 10^5 \text{ m/s})} = 3.64 \text{ nm}$$

This wavelength is in the x-ray region.

- 38.14** A stream of photons impinging normally on a completely absorbing screen in vacuum exerts a pressure \mathcal{P} . Show that $\mathcal{P} = I/c$, where I is the irradiance.

▮ The time rate of change of momentum equals the force, that is, $\Delta p/\Delta t = F$. The force per unit area, F/A , is the pressure, and so

$$\mathcal{P} = \frac{1}{A} \frac{\Delta p}{\Delta t}$$

But $\mathcal{E} = cp$ for photons, which means that $\Delta \mathcal{E} = c \Delta p$ and

$$\mathcal{P} = \frac{1}{Ac} \frac{\Delta \mathcal{E}}{\Delta t}$$

Since irradiance by definition is energy per unit area per unit time, we obtain $\mathcal{P} = I/c$.

- 38.15** A collimated beam of light of flux density 30 kW/m^2 is incident normally on a 100-mm^2 completely absorbing screen. Using the results of Prob. 38.14, determine both the pressure exerted on and the momentum transferred to the screen during a 1000-s interval.

▮ The pressure is simply

$$\mathcal{P} = \frac{I}{c} = \frac{3 \times 10^4}{3 \times 10^8} = 10^{-4} \text{ Pa} = \frac{F}{A} = \frac{(\Delta p / \Delta t)}{A} \quad \text{and} \quad \Delta p = \mathcal{P} A \Delta t = (10^{-4})(10^{-4})(10^3) = 10^{-5} \text{ kg} \cdot \text{m/s}$$

(One could actually build an interplanetary sailboat using solar pressure.)

- 38.16** What is the largest momentum we can expect for a microwave photon?

▮ Microwave frequencies go up to $3 \times 10^{11} \text{ Hz}$. Therefore, since $p = h/\lambda = (h\nu)/c$,

$$p = \frac{(6.6 \times 10^{-34})(3 \times 10^{11})}{3 \times 10^8} = 6.6 \times 10^{-31} \text{ kg} \cdot \text{m} \cdot \text{s}^{-1}$$

- 38.17** How many red photons ($\lambda = 663 \text{ nm}$) must strike a totally *reflecting* screen per second, at normal incidence, if the exerted force is to be 0.225 lb ?

▮ We know that $F = \Delta p / \Delta t$ and, in this case, Δp is *twice* the incident momentum. Thus, if N is the number of incoming photons per second, $F = N[(2h)/\lambda]$. Since $0.225 \text{ lb} = 1 \text{ N}$, we have $F = 1$, and

$$N = \frac{\lambda}{2h} = \frac{663 \times 10^{-9}}{2(6.63 \times 10^{-34})} = 5 \times 10^{26} \text{ photons/s}$$

- 38.18** What potential difference must be applied to stop the fastest photoelectrons emitted by a nickel surface under the action of ultraviolet light of wavelength 2000 \AA ? The work function of nickel is 5.00 eV .

▮ energy of photon = $\frac{hc}{\lambda} = \frac{1240 \text{ eV} \cdot \text{nm}}{200 \text{ nm}} = 6.20 \text{ eV}$

Then, from the photoelectric equation, the energy of the fastest emitted electron is $6.20 \text{ eV} - 5.00 \text{ eV} = 1.20 \text{ eV}$. Hence a retarding potential of 1.20 V is required.

- 38.19** The work function of sodium metal is 2.3 eV . What is the longest-wavelength light that can cause photoelectron emission from sodium?

▮ At threshold, the photon energy just equals the energy required to tear the electron loose from the metal, namely, the work function W_{\min} .

$$W_{\min} = \frac{hc}{\lambda} \quad \text{or} \quad \lambda = \frac{1240 \text{ eV} \cdot \text{nm}}{2.3 \text{ eV}} = \underline{540 \text{ nm}}$$

- 38.20** What is the work function of sodium metal if the photoelectric threshold wavelength is 680 nm ?

▮ work function = $W_{\min} = h\nu_{\min} = \frac{hc}{\lambda_{\max}} = \frac{1240 \text{ eV} \cdot \text{nm}}{680 \text{ nm}} = \underline{1.83 \text{ eV}}$

- 38.21** Will photoelectrons be emitted by a copper surface, of work function 4.4 eV , when illuminated by visible light?

▮ As in Prob. 38.19,

$$\text{threshold } \lambda = \frac{hc}{W_{\min}} = \frac{1240 \text{ eV} \cdot \text{nm}}{4.4 \text{ eV}} = 282 \text{ nm}$$

Hence visible light (400 to 700 nm) cannot eject photoelectrons from copper.

- 38.22** Light of wavelength 600 nm falls on a metal having photoelectric work function 2 eV . Find (a) the energy of a photon, (b) the kinetic energy of the most energetic photoelectron, and (c) the stopping potential.

▮ (a) $E = \frac{hc}{\lambda} = \frac{1240 \text{ eV} \cdot \text{nm}}{600 \text{ nm}} = 2.07 \text{ eV}$

$$(b) \quad K_{\max} = E - W_{\min} = 2.07 - 2 = 0.07 \text{ eV}$$

$$(c) \quad eV_s = K_{\max} = 0.07 \text{ eV} \quad \text{or} \quad V_s = 0.07 \text{ V}$$

38.23 It takes 4.2 eV to remove one of the least tightly bound electrons from a metal surface. When ultraviolet photons of a single frequency strike a metal, electrons with kinetic energies from zero to 2.6 eV are ejected. What is the energy of the incident photons?

$$\blacksquare \quad WF = 4.2 \text{ eV} \quad KE_{\max} = 2.6 \text{ eV} \quad \text{and} \quad E_{\text{photon}} = WF + KE_{\max} = 4.2 + 2.6 = \underline{6.8 \text{ eV}}$$

38.24 A photon of energy 4.0 eV imparts all its energy to an electron that leaves a metal surface with 1.1 eV of kinetic energy. What is the work function W_{\min} of the metal?

$$\blacksquare \quad W_{\min} = h\nu - K_{\max} = 4.0 - 1.1 = \underline{2.9 \text{ eV}}$$

38.25 Determine the maximum KE of photoelectrons ejected from a potassium surface by ultraviolet light of wavelength 2000 Å. What retarding potential difference is required to stop the emission of electrons? The photoelectric threshold wavelength for potassium is 4400 Å.

$$\blacksquare \quad \text{Work function} = W_{\min} = \frac{hc}{\lambda_{\max}} = \frac{12400 \text{ eV} \cdot \text{Å}}{4400 \text{ Å}} = 2.82 \text{ eV}$$

$$\text{then} \quad \frac{hc}{\lambda} - \frac{hc}{\lambda_{\max}} = KE_{\max} = \frac{12400}{2000} - 2.82 = 6.20 - 2.82 = \underline{3.38 \text{ eV}}$$

The retarding potential must be just large enough to stop electrons with KE_{\max} , so $V = \underline{3.38 \text{ V}}$.

38.26 A surface has light of wavelength $\lambda_1 = 550 \text{ nm}$ incident on it, causing the ejection of photoelectrons for which the stopping potential is $V_{s1} = 0.19 \text{ V}$. Suppose that radiation of wavelength $\lambda_2 = 190 \text{ nm}$ were incident on the surface. Calculate (a) the stopping potential V_{s2} , (b) the work function of the surface, and (c) the threshold frequency for the surface.

(a) Since $eV = KE_{\max} = h\nu - W_{\min}$, with W_{\min} a constant of the surface, we have $e(V_{s2} - V_{s1}) = h(\nu_2 - \nu_1)$ or

$$V_{s2} = V_{s1} + \frac{h}{e}(\nu_2 - \nu_1) = V_{s1} + \frac{hc}{e} \left(\frac{1}{\lambda_2} - \frac{1}{\lambda_1} \right) = 0.19 + 1240 \left(\frac{1}{190} - \frac{1}{550} \right) = \underline{4.47 \text{ V}}$$

$$(b) \quad W_{\min} = \frac{hc}{\lambda_1} - eV_{s1} = \frac{1240}{550} - 0.19 = \underline{2.07 \text{ eV}}$$

$$(c) \quad h\nu_c = W_{\min} \quad \text{or} \quad \nu_c = \frac{W_{\min}}{h} = \frac{(2.07)(1.602 \times 10^{-19})}{6.63 \times 10^{-34}} = \underline{498 \text{ THz}}$$

38.27 In the photoionization of atomic hydrogen, what will be the maximum kinetic energy of the ejected electron when a 60-nm photon is absorbed by the atom? The ionization energy of H is 13.6 eV.

(a) The ionization energy is minimum energy to remove the electron from the atom. Then

$$K_{\max} = \frac{hc}{\lambda} - 13.6 \text{ eV} = \frac{1240 \text{ eV} \cdot \text{nm}}{60 \text{ nm}} - 13.6 \text{ eV} = \underline{7.1 \text{ eV}}$$

38.2 COMPTON SCATTERING; X-RAYS; PAIR PRODUCTION AND ANNIHILATION

38.28 Suppose that a 3.64 nm photon going in the $+x$ direction collides head-on with a $2 \times 10^5 \text{ m/s}$ electron moving in the $-x$ direction. If the collision is perfectly elastic, what are the conditions after collision.

(a) From the law of conservation of momentum,

$$\text{momentum before} = \text{momentum after} \quad \frac{h}{\lambda_0} - mv_0 = \frac{h}{\lambda} - mv$$

But, from Prob. 38.13, $h/\lambda_0 = mv_0$ in this case. Hence, $h/\lambda = mv$. Also, for a perfectly elastic collision,

$$\text{KE before} = \text{KE after} \quad \frac{hc}{\lambda_0} + \frac{1}{2}mv_0^2 = \frac{hc}{\lambda} + \frac{1}{2}mv^2$$

Using the facts that $h/\lambda_0 = mv_0$ and $h/\lambda = mv$, we find that

$$v_0(c + \frac{1}{2}v_0) = v(c + \frac{1}{2}v)$$

Therefore $v = v_0$ and the electron rebounds with its original speed. Because $h/\lambda = mv = mv_0$, the photon also rebounds and with its original wavelength.

- 38.29** The Compton equation can be written as $\lambda' - \lambda = [h/(m_0c)](1 - \cos \phi)$. The factor $h/(m_0c)$, called the Compton wavelength, is the wavelength shift that occurs when $\phi = 90^\circ$. Evaluate it for scattering from (a) electrons and (b) protons. In the case of electrons, what percentage change is this if the incident radiation has a wavelength (c) 500 nm (visible light) and (d) 0.050 nm (0.5-Å x-rays)?

| Inserting the rest masses of the electron (9.1×10^{-31} kg) and proton (1.67×10^{-27} kg) into h/mc yields Compton wavelengths of 0.024 Å and 1.32×10^{-15} m, respectively. For the electron $(0.024/500)(100) = 4.8 \times 10^{-4}$ percent, while for the 0.5-Å x-ray, $(0.024/0.500)(100) = 4.8$ percent.

- 38.30** A photon ($\lambda = 0.400$ nm) strikes an electron at rest and rebounds at an angle of 150° to its original direction. Find the speed and wavelength of the photon after the collision.

| The speed of a photon is always the speed of light in vacuum, c . To obtain the wavelength after collision, we use the equation for the Compton effect:

$$\begin{aligned} \lambda' &= \lambda + \frac{h}{mc} (1 - \cos \phi) = 4 \times 10^{-10} \text{ m} + \frac{6.63 \times 10^{-34} \text{ J} \cdot \text{s}}{(9.1 \times 10^{-31} \text{ kg})(3 \times 10^8 \text{ ms})} (1 - \cos 150^\circ) \\ &= 4 \times 10^{-10} \text{ m} + (2.43 \times 10^{-12} \text{ m})(1 + 0.866) = \underline{0.4045 \text{ nm}} \end{aligned}$$

- 38.31** Suppose that a beam of 0.2-MeV photons is scattered by the electrons in a carbon target. (a) What is the wavelength associated with these photons? (b) What is the wavelength of those photons scattered through an angle of 90° ? (c) What is the energy of the scattered photons that emerge at an angle of 60° relative to the incident direction?

| (a)
$$\lambda = \frac{hc}{E} = \frac{1240 \text{ MeV} \cdot \text{fm}}{0.2 \text{ MeV}} = \underline{6200 \text{ fm}}$$

(b)
$$\lambda' = \lambda + \frac{h}{m_e c} (1 - \cos \theta) = 6200 + (2430)(1 - 0) = \underline{8630 \text{ fm}}$$

(c)
$$\frac{hc}{\lambda'} = \frac{hc}{\lambda + [h/(m_e c)](1 - \cos \theta)} = \frac{1240}{6200 + (2430)(1 - \frac{1}{2})} = \underline{0.168 \text{ MeV}}$$

- 38.32** Verify Compton's equation (Prob. 38.29) when the photon is back-scattered ($\phi = 180^\circ$).

| Assuming the electron to be at rest initially, we have from conservation of momentum

$$\frac{h}{\lambda} = P - \frac{h}{\lambda'} \quad \text{or} \quad P = h\left(\frac{1}{\lambda} + \frac{1}{\lambda'}\right)$$

and from conservation of relativistic energy

$$\frac{hc}{\lambda} + E_0 = \frac{hc}{\lambda'} + E \quad \text{or} \quad E = E_0 + hc\left(\frac{1}{\lambda} - \frac{1}{\lambda'}\right)$$

Substituting these expressions for the electron's final momentum and final energy into the momentum-energy relation for the electron, we obtain

$$\left[E_0 + hc\left(\frac{1}{\lambda} - \frac{1}{\lambda'}\right)\right]^2 = E_0^2 + \left[hc\left(\frac{1}{\lambda} + \frac{1}{\lambda'}\right)\right]^2 \quad 2E_0hc\left(\frac{1}{\lambda} - \frac{1}{\lambda'}\right) - 2h^2c^2\frac{1}{\lambda\lambda'} = 2h^2c^2\frac{1}{\lambda\lambda'} \quad E_0(\lambda' - \lambda) = 2hc$$

whence $\lambda' - \lambda = (2hc)/E_0 = (2h)/(m_e c)$, which is Compton's equation with $\cos \phi = -1$.

- 38.33** A photon strikes a free electron at rest and is scattered straight backward. If the electron's speed after collision is αc , where $\alpha \ll 1$, show that the electron's kinetic energy is a fraction α of the photon's initial energy.

| Since $v = \alpha c$ and $\alpha \ll 1$, the electron is nonrelativistic. Conservation of momentum yields $h/\lambda + h/\lambda' = mv$; multiplying by c , $(hc)/\lambda + (hc)/\lambda' = mvc = (mv^2)/\alpha$. The energy equation is $(hc)/\lambda - (hc)/\lambda' = (mv^2)/2$.

Adding we find that $(hc)/\lambda = E_\gamma = (mv^2)/4 + (mv^2)/(2\alpha)$. Since $\alpha \ll 1$, $(mv^2)/4$ is neglected and $(mv^2)/2 = \alpha E_\gamma$.

- 38.34** A photon with $\lambda = 0.5 \text{ nm}$ strikes a free electron head-on and is scattered straight backward. If the electron is initially at rest, what is its speed after the collision?

▮ Momentum conservation gives $h/\lambda = m_0 v_x - h/\lambda'$, assuming that the scattered electron is nonrelativistic. λ is given as 0.5 nm and λ' for 180° scattering is $0.5 \text{ nm} + (2h)/(m_0 c) = 0.5048 \text{ nm}$, so $v_x = (h/m_0)/(1/\lambda + 1/\lambda') = [(6.63 \times 10^{-34})/(9.1 \times 10^{-31})](3.98 \times 10^9) = 2.9 \times 10^6 \text{ m/s}$.

- 38.35** A photon with $\lambda = 0.5 \text{ nm}$ is moving along the x axis when it strikes a free electron (initially at rest) and is scattered so as to move along the y axis. What are the x and y components of the electron's velocity after collision?

▮ In the x direction, conservation of momentum yields $h/\lambda = m_0 v_x$ and in y direction $h/\lambda' + m_0 v_y = 0$. From the Compton scattering relation for $\phi = 90^\circ$, $\lambda' = \lambda + 0.024 \text{ \AA} = 5.0 + 0.024 = 5.024 \text{ \AA}$. Solving for v_x and v_y from above, with m_0 the electron rest mass, gives $v_x = +1.46 \times 10^6 \text{ m/s}$ and $v_y = -1.46 \times 10^6 \text{ m/s}$; the electron is nonrelativistic.

- 38.36** Derive the Compton equation, using the relativistic expressions for the energy and momentum of the electron.

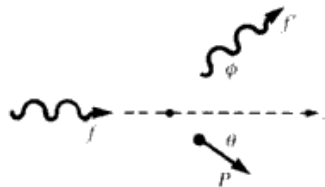

Fig. 38-1

▮ For notation, see Fig. 38-1.

$$\text{conservation of } x \text{ momentum: } \frac{hf}{c} = \frac{hf'}{c} \cos \phi + P \cos \theta \quad (1)$$

$$\text{conservation of } y \text{ momentum: } 0 = \frac{hf'}{c} \sin \phi - P \sin \theta \quad (2)$$

$$\text{energy conservation: } hf + m_0 c^2 = hf' + (P^2 c^2 + m_0^2 c^4)^{1/2} \quad (3)$$

- (i) Solve (1) for $P \cos \theta$ and (2) for $P \sin \theta$. Square and add; $h^2 f^2 - 2h^2 f f' \cos \phi + h^2 f'^2 = c^2 P^2$.
- (ii) Square (3) to obtain: $h^2 f^2 + h^2 f'^2 - 2h^2 f f' + 2hm_0 c^2 (f - f') = c^2 P^2$.
- (iii) Subtract: $(f - f')/ff' = [h/(m_0 c^2)](1 - \cos \phi)$.
- (iv) But $f = c/\lambda$ and so $(f - f')/(ff') = (\lambda' - \lambda)/c$.
- (v) Therefore, $\lambda' - \lambda = [h/(m_0 c)](1 - \cos \phi)$.

- 38.37** In what amounts to the inverse of the photoelectric effect, x-ray photons are produced when a tungsten target is bombarded by accelerated electrons. If an x-ray machine has an accelerating potential of 60 kV , what is the shortest wavelength present in its radiation?

▮ Since the work function of tungsten is very much smaller than the accelerating potential, we may suppose that the entire kinetic energy of an electron is lost to create a single photon of maximum energy:

$$eV = \frac{hc}{\lambda_{\min}} \quad \lambda_{\min} = \frac{hc}{eV} = \frac{1240 \text{ keV} \cdot \text{pm}}{60 \text{ keV}} = 20.7 \text{ pm}$$

- 38.38** An electron is shot down an x-ray tube. Its energy just before it strikes the target of the tube is 30 keV . If it loses all this energy in a single collision with a very massive atom, what is the wavelength of the single x-ray photon that is emitted?

$$\text{▮ } E = \frac{hc}{\lambda} = \frac{1.24 \text{ keV} \cdot \text{nm}}{\lambda} \quad \lambda = \frac{1.24}{30} = 0.0413 \text{ nm} = 0.413 \text{ \AA}$$

▮ For Bragg reflection the scattering angle is given by $\sin \theta = (n\lambda)/(2d) = [(2)(1.2)]/4.4$, and $\theta = 33^\circ$.

38.47 The attenuation coefficient of aluminum for soft X-rays is 1.73/cm. Compute the fraction of these X-rays transmitted by an aluminum sheet 1.156 cm thick.

▮ The exponential law of attenuation is

$$I = I_0 e^{-\mu x} \quad \frac{I}{I_0} = e^{-1.73(1.156)} = e^{-2} = \frac{1}{e^2} = \frac{1}{2.718^2} = 0.135 \quad \text{or} \quad \underline{13.5\% \text{ transmitted}}$$

38.48 One-half the intensity of a homogeneous x-ray beam is removed by an aluminum filter 5 mm thick. What is the fraction of this homogeneous beam that would be removed by 15 mm of aluminum?

▮ $\frac{I_1}{I_0} = e^{-\mu x} \quad \frac{1}{2} = e^{-5\mu} \quad \frac{I_2}{I_0} = e^{-15\mu} = (e^{-5\mu})^3 = \left(\frac{1}{2}\right)^3 = \frac{1}{8}$ (fraction remaining) $1 - \frac{1}{8} = \frac{7}{8}$ (fraction removed)

38.49 Show that when a positron and an electron (both essentially at rest) annihilate, creating two photons, either photon has the Compton wavelength (Prob. 38.29).

▮ Total energy before annihilation is $2m_e c^2$; and after, $2[(hc)/\lambda]$ (momentum conservation requires that the photon energies be equal). Then, by conservation of energy,

$$2m_e c^2 = 2 \frac{hc}{\lambda} \quad \text{or} \quad \lambda = \frac{h}{m_e c} = 2430 \text{ fm}$$

38.50 Show that the threshold wavelength for the production of a positron-electron pair is half the Compton wavelength.

▮ The incident photon must have at least enough energy to create a pair having zero kinetic energy (we ignore any kinetic energy of the recoil nucleus). Thus,

$$\frac{hc}{\lambda} \geq 2m_e c^2 \quad \text{or} \quad \lambda \leq \frac{h}{2m_e c} = \underline{1215 \text{ fm}}$$

38.51 After pair annihilation, two 1-MeV photons move off in opposite directions. Find the kinetic energy of the electron and positron.

▮ The two photons have the same energy, and hence the same momentum, which we are told are in opposite directions. Thus by momentum conservation the electron and positron must have had equal and opposite momentum. Hence their kinetic energies are equal. By energy conservation: $2 \text{ MeV} = 2(m_0 c^2) + 2 \text{ KE} = 2(0.51) \text{ MeV} + 2 \text{ KE}$ and KE of each = 0.49 MeV.

38.3 DE BROGLIE WAVES AND THE UNCERTAINTY PRINCIPLE

38.52 A proton is accelerated through a potential difference of 1000 V. What is its de Broglie wavelength?

▮ We have $\lambda = h/(mv)$. But $m \approx m_0$ (nonrelativistic), so v may be found from $(mv^2)/2 = 1000e$. Substitution gives $\lambda = \underline{9.1 \times 10^{-13} \text{ m}}$.

38.53 Find the de Broglie wavelength of a thermal neutron of mass $1.67 \times 10^{-27} \text{ kg}$ traveling at a speed of 2200 m/s.

▮ Use the de Broglie wave equation.

$$\lambda = \frac{h}{mv} = \frac{6.63 \times 10^{-34}}{1.67 \times 10^{-27}(2200)} = \underline{0.18 \text{ nm}}$$

38.54 What is the de Broglie wavelength for a particle moving with speed $2 \times 10^6 \text{ m/s}$ if the particle is (a) an electron, (b) a proton, and (c) a 0.2-kg ball?

▮ We make use of the definition of the de Broglie wavelength:

$$\lambda = \frac{h}{mv} = \frac{6.63 \times 10^{-34} \text{ J} \cdot \text{s}}{m(2 \times 10^6 \text{ m/s})} = \frac{3.3 \times 10^{-40} \text{ m} \cdot \text{kg}}{m}$$

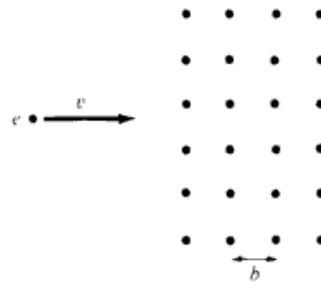

Fig. 38-4

substitution, $T = 4.25 \times 10^{-26}/m$. Using the electron mass and the helium mass ($4 \times 1.67 \times 10^{-27}$ kg), we have $T_e = 46\,600$ K and $T_{He} = 6.3$ K.

- 38.60** Consider a beam of electrons shot toward a crystal, as shown in Fig. 38-4. The crystal spacing is b , as indicated. For what de Broglie wavelengths will the electron beam be strongly reflected straight back upon itself? For what electron kinetic energies? It is found by experiment that electrons having these energies are unable to move through such a crystal in the direction shown. Evaluate the energies in eV for $b = 2 \times 10^{-10}$ m.

▮ Strong reflection will occur if $2b = n\lambda$, because the beams reflected from successive planes will then reinforce. Therefore, $\lambda = (2b)/n$. For nonrelativistic electrons $E_n = (p_n^2)/(2m) = h^2/(2m\lambda_n^2) = (n^2h^2)/(8b^2m)$, which gives $E_n = 9.4n^2$ eV.

- 38.61** The nuclei of atoms have radii of order 10^{-15} m. Consider a hypothetical situation of a proton confined to a narrow tube with length 2×10^{-15} m. What will be the de Broglie wavelengths which will resonate in the tube? To what momentum does the longest wavelength correspond? If relativistic effects are assumed negligible, to what energy (in eV) does this correspond?

▮ This is a simple standing-wave problem. For symmetric boundary conditions, the allowed λ 's are $\lambda_n = (2L)/n = [(4 \times 10^{-15})/n]$ m; since $\lambda_n = h/p_n$, $p_n = (nh)/(2L) = n(1.66 \times 10^{-19})$. Nonrelativistic kinetic energy = $E_n = p_n^2/(2m) = n^2(8.2 \times 10^{-12}$ J) or $n^2(51$ Mev). $n = 1$ corresponds to longest wavelength.

- 38.62** At what energy will the nonrelativistic calculation of the de Broglie wavelength of an electron be in error by 5 percent?

▮ For the nonrelativistic case, the de Broglie wavelength is

$$\lambda_{nr} = \frac{hc}{pc} = \frac{hc}{\sqrt{2m_0c^2K}}$$

For the relativistic case,

$$(K + m_0c^2)^2 = (pc)^2 + (m_0c^2)^2 \quad \text{or} \quad pc = \left[2m_0c^2K \left(1 + \frac{K}{2m_0c^2} \right) \right]^{1/2}$$

and the de Broglie wavelength is

$$\lambda_r = \frac{hc}{pc} = \frac{hc}{\{2m_0c^2K[1 + K/(2m_0c^2)]\}^{1/2}}$$

For our case, $\lambda_{nr} - \lambda_r = 0.05\lambda_r$; $\lambda_{nr}/\lambda_r = 1.05$.

$$\frac{\lambda_{nr}}{\lambda_r} = \sqrt{1 + \frac{K}{2m_0c^2}} \quad 1.05 = \sqrt{1 + \frac{K}{2(0.511 \text{ MeV})}}$$

Solving, $K = 0.105$ MeV.

- 38.63** Show that the de Broglie wavelength of a particle is approximately the same as that of a photon with the same energy, when the energy of the particle is much greater than its rest energy.

▮ $E^2 = p^2c^2 + E_0^2$ or $p = \frac{E}{c} \sqrt{1 - \left(\frac{E_0}{E}\right)^2} \approx \frac{E}{c}$ if $E \gg E_0$. So $\lambda = \frac{h}{p} \approx \frac{hc}{E}$

For a photon, $E = h\nu = (hc)/\lambda_\gamma$, so $\lambda_\gamma = (hc)/E \approx \lambda$.

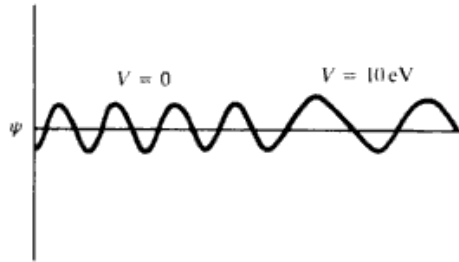

Fig. 38-5

38.64 An electron is confined to a tube of length L . The electron's potential energy in one half of the tube is zero, while the potential energy in the other half is 10 eV. If the electron has a total energy $E = 15$ eV, what will be the ratio of the de Broglie wavelength of the electron in the 10-eV region of the tube to that in the other half of the tube? Sketch the wave function ψ for the electron along the tube.

▮ The wave function is sketched in Fig. 38-5. $\lambda = h/p = h/(2mK)^{1/2}$; with K the kinetic energy of the electron, $\lambda_1/\lambda_2 = (K_2/K_1)^{1/2} = (15/5)^{1/2} = 1.73$.

38.65 A particle of mass m is confined to a one-dimensional line of length L . From arguments based on the wave interpretation of matter, show that the energy of the particle can have only discrete values and determine these values.

▮ If the particle is confined to a line segment, say from $x = 0$ to $x = L$, the probability of finding the particle outside this region must be zero. Therefore, the wave function ψ must be zero for $x \leq 0$ or $x \geq L$, since the square of ψ gives the probability for finding the particle at a certain location. Inside the limited region the wavelength of ψ must be such that ψ vanishes at the boundaries $x = 0$ and $x = L$, so that it can vary continuously to the outside region. Hence only those wavelengths will be possible for which an integral number of half wavelengths fit between $x = 0$ and $x = L$, that is, $L = (n\lambda)/2$, where n is an integer, called the *quantum number*, with values $n = 1, 2, 3, \dots$. From the de Broglie relationship $\lambda = h/p$ we then find that the particle's momentum can have only discrete values given by

$$p = \frac{h}{\lambda} = \frac{nh}{2L}$$

Since the particle is not acted upon by any forces inside the region, its potential energy will be a constant which we set equal to zero. Therefore the energy of the body is entirely kinetic and will have the discrete values obtained from

$$E = K = \frac{1}{2}mv^2 = \frac{p^2}{2m} = \frac{[(nh)/(2L)]^2}{2m} \quad \text{that is,} \quad E_n = n^2 \frac{h^2}{8mL^2} \quad n = 1, 2, 3, \dots$$

This very simple problem illustrates one of the basic features of the probability interpretation of matter; namely, that the energy of a bound system can take on only discrete values, with zero energy not being a possible value.

38.66 Assume that the uncertainty in the position of a particle is equal to its de Broglie wavelength. Show that the uncertainty in its velocity is equal to or greater than $1/(4\pi)$ times its velocity.

▮ Use the Heisenberg uncertainty principle with $\Delta x = \lambda = h/(mv_x)$.

$$\Delta x \Delta(mv_x) \geq \frac{h}{4\pi} \quad \frac{h}{mv_x} \Delta(mv_x) \geq \frac{h}{4\pi}$$

Since m is constant,

$$\frac{h}{mv_x} (m \Delta v_x) \geq \frac{h}{4\pi} \quad \frac{h}{v_x} \Delta v_x \geq \frac{h}{4\pi} \quad \Delta v_x \geq \frac{1}{4\pi} v_x$$

38.67 If the uncertainty in the time during which an electron remains in an excited state is 10^{-7} s, what is the least uncertainty (in J) in the energy of the excited state?

▮ Let W be the energy of the excited state.

$$\Delta W \Delta t \geq \frac{h}{4\pi} \quad (\Delta W)(10^{-7}) \geq \frac{6.63 \times 10^{-34}}{4\pi} \quad \Delta W \geq \frac{6.63 \times 10^{-27}}{4\pi} \geq 0.528 \times 10^{-27} \text{ J}$$



Các trang còn thiếu:

102-235, 239-243, 245-250, 257-272, 277-278, 284-290, 295-326,
329-340, 344-349, 353-360, 363-371, 374, 377, 381-430, 434-465,
467-468, 470-472, 474-518, 520-679, 681-685, 687-688, 691-702,
704, 706, 708, 714, 716, 719-737

Nitin M Sir

SCHAUM'S—THE ORIGINAL SOLVED-PROBLEM STUDY GUIDE

Master physics with Schaum's—the high-performance solved-problem guide. It will help you cut study time, hone problem-solving skills, and achieve your personal best on exams!

SCHAUM'S
Solved Problems Series

OVER 30 MILLION SOLD

Students love Schaum's Solved Problem Guides because they produce results. Each year, thousands of students improve their test scores and final grades with these indispensable guides.

Get the edge on your classmates. Use Schaum's!

If you don't have a lot of time but want to excel in class, use this book to:

- **Brush up before tests**
- **Study quickly and more effectively**
- **Learn the best strategies for solving tough problems in step-by-step detail**

Inside you will find:

- 3000 solved problems with complete solutions—the largest selection of solved problems yet published on this subject
- An index to help you quickly locate the types of problems you want to solve
- Problems like those you'll find on your exams
- Techniques for choosing the correct approach to problems
- Guidance toward the quickest, most efficient solutions

Review what you've learned in class by solving thousands of related problems that test your skill. Compatible with any classroom text, Schaum's Solved Problem Guides let you practice at your own pace and remind you of all the important problem-solving techniques you need to remember—fast! And Schaum's are so complete, they're perfect for preparing for graduate or professional exams.

If you want top grades and thorough understanding of physics, this powerful study tool is the best tutor you can have!

Chapters include: • Mathematical Introduction • Equilibrium of Concurrent Forces • Kinematics in One Dimension • Newton's Laws of Motion • Motion in a Plane I • Motion in a Plane II • Work and Energy • Power and Simple Machines • Impulse and Momentum • Statics of Rigid Bodies • Rotational Motion I: Kinematics and Dynamics • Rotational Motion II: Kinetic Energy, Angular Impulse, Angular Momentum • Matter in Bulk • Simple Harmonic Motion • Hydrostatics • Hydrodynamics • Temperature and Thermal Expansion • Heat and Calorimetry • Heat Transfer • Gas Laws and Kinetic Theory • The First Law of Thermodynamics • The Second Law of Thermodynamics • Wave Motion • Sound • Coulomb's Law and Electric Fields • Electric Potential and Capacitance • Simple Electric Circuits • The Magnetic Field • Magnetic Properties of Matters • Induced EMF: Generators and Motors • Inductance • Electromagnetic Waves • Light and Optical Phenomena • Mirrors, Lenses, and Optical Instruments • Interference, Diffraction, and Polarization • Special Relativity • Particles of Light and Waves of Matter • Modern Physics: Atoms, Nuclei, Solid-State Electronics

McGraw-Hill

A Division of The McGraw-Hill Companies



\$27.95 U.S.A.

ISBN 0-07-025734-5



9 780070 257344

5 2 7 9 5



Other Titles in Schaum's Solved Problems Series

3000 Solved Problems in **Biology**

3000 Solved Problems in **Calculus**

3000 Solved Problems in **Chemistry**

2500 Solved Problems in **College Algebra and Trigonometry**

2500 Solved Problems in **Differential Equations**

2000 Solved Problems in **Discrete Mathematics**

3000 Solved Problems in **Electric Circuits**

2000 Solved Problems in **Electromagnetics**

2000 Solved Problems in **Electronics**

2500 Solved Problems in **Fluid Mechanics & Hydraulics**

1000 Solved Problems in **Heat Transfer**

3000 Solved Problems in **Linear Algebra**

2000 Solved Problems in **Mechanical Engineering/ Thermodynamics**

2000 Solved Problems in **Numerical Analysis**

2000 Solved Problems in **Organic Chemistry**

2000 Solved Problems in **Physical Chemistry**

3000 Solved Problems in **Precalculus**

800 Solved Problems in **Vector Mechanics for Engineers/ Statics**

700 Solved Problems in **Vector Mechanics for Engineers/ Dynamics**