

Candidate Name _____

Centre Number				Candidate Number									

EXAMINATIONS COUNCIL OF ZAMBIA

Examination for General Certificate of Education Ordinary Level

Science
Paper 2: (Physics)

5124/2

Monday

25 JULY 2016

- Additional materials:
- Mathematical tables or Scientific calculator (non programmable)
 - Graph paper
 - Answer Booklet

Time: 1 hour 15 minutes

Instructions to Candidates

Write your name, centre number and candidate number at the top of this page and on any separate Answer Booklet used.

There are **twelve (12)** questions in this paper.

Section A

Answer **all** the questions.

Write your answers in the spaces provided on the question paper.

Section B

Answer any **two** questions.

Write your answers on the Answer Booklet provided.

At the end of the examination

- 1** Fasten Answer Booklet used securely to the question paper.
- 2** Enter the numbers of the **Section B** questions you have answered in the grid below.

Information for Candidates

The number of marks is given in brackets [] at the end of each question or part question.

Cell phones are not allowed in the Examination room.

Candidate's use	Examiner's use
Section A	
Section B	
Total	

Section A

[45 marks]

Answer all questions.

Write your answers in the spaces provided on the question paper.

- 1** **Figure 1.1** shows an experiment which was carried out to measure the time interval of a simple pendulum.

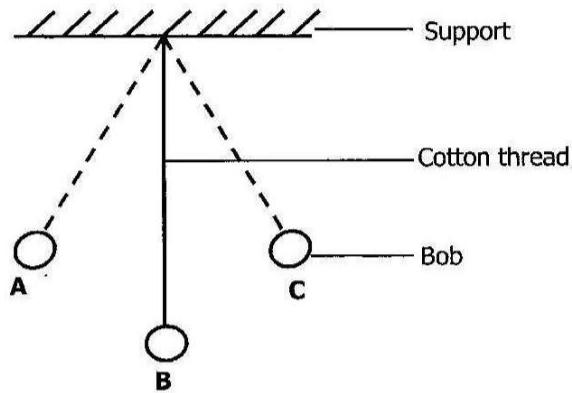

Figure 1.1

The bob was oscillating between **A** and **C**.

- (a)** State the meaning of the term 'Oscillation'.

..... [1]

- (b)** If the pendulum bob took 0.20s to swing from **A** to **C**, calculate the period.

Period _____ [2]

- (c)** Using your answer to **1 (b)**, determine the frequency of the bob.

Frequency _____ [2]

[Total:5]

2 A lion of mass 200kg is transferred from the moon to Earth. Acceleration of free fall on the moon is 1.67m/s^2 while that on Earth is 10m/s^2 .

(a) State

(i) an instrument commonly used in the laboratory for measuring the amount of material in a body.

..... [1]

(ii) the mass of the 200kg lion on Earth.

Mass _____ [1]

(b) Calculate the weight of the lion on Earth.

Weight _____ [2]

[Total:4]

3 (a) What is meant by the 'moment' of a force about a point?

..... [1]

(b) Moment of a force about a point depends on two factors; what are they?

..... [2]

(c) **Figure 3.1** shows a uniform metre rule which is pivoted at the 20cm mark and balanced horizontally by an object of weight 3.15N placed at the 10cm mark.

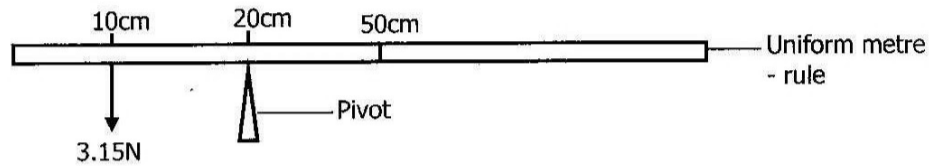

Figure 3.1

Calculate the weight of the metre rule.

Weight _____ [2]

[Total:5]

- 4 **Figure 4.1** shows a stone of mass 2kg which drops from the top of a cliff and takes two seconds to strike the ground. Acceleration of free fall, $g = 10\text{m/s}^2$.

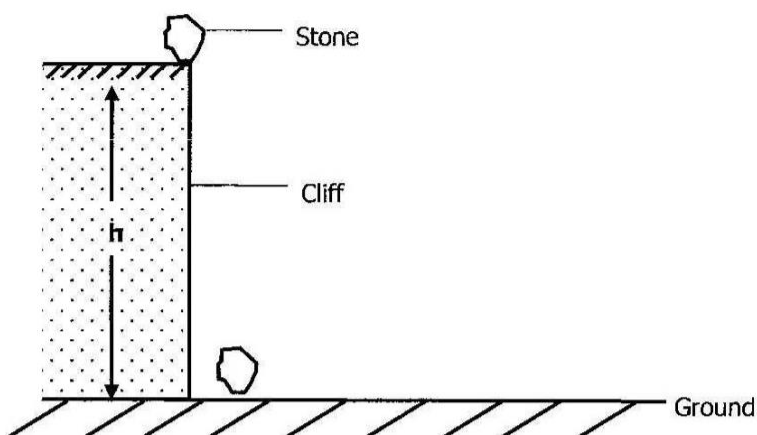

Figure 4.1

- (a) Name the form of energy possessed by the stone before it falls.

..... [1]

- (b) Determine the height h of the cliff.

Height, h _____ [2]

- (c) Calculate

- (i) the kinetic energy of the stone when half way down.

Kinetic energy _____ [2]

- (ii) the final velocity of the stone as it strikes the ground.

Velocity _____ [2]

[Total:7]

[Turn over

- 5 Two metal plates **A** and **B**, one with shiny surfaces and the other painted black are heated to a temperature of 100°C. The metal plates are then placed in the open air or insulating materials and allowed to cool. The table below shows the results obtained with time.

Time in seconds	Temperature of metal plate in °C	
	A	B
0	100	100
30	92	85
60	87	74
90	84	67
120	81	63
150	79	60

- (a) By what process(es) of heat transfer are the metal plates losing heat to the surrounding?

.....
 [1]

- (b) Which metal plate is losing heat faster?

.....
 [1]

- (c) State, with a reason which metal plate **A** or **B** has shiny surfaces.

Metal plate..... [1]

Reason [1]

[Total:4]

6 **Figure 6.1** shows a vibrating tuning fork, **Y** in air.

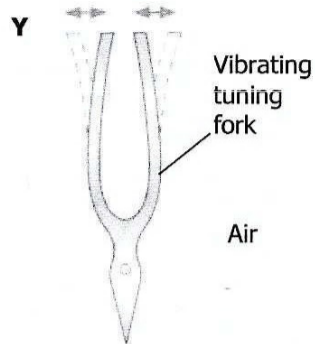

Figure 6.1

(a) State the nature of wave produced by the tuning fork.

..... [1]

(b) Show diagrammatically the regions created by the wave produced, as it passes through the air. [3]

(c) Explain what happens to the speed of the wave in (a) if the rate of vibration of **Y** increases but the length of the wave produced remains the same.

.....
.....
..... [2]

[Total:6]

7 Figure 7.1 shows a ray of light entering and leaving a glass block.

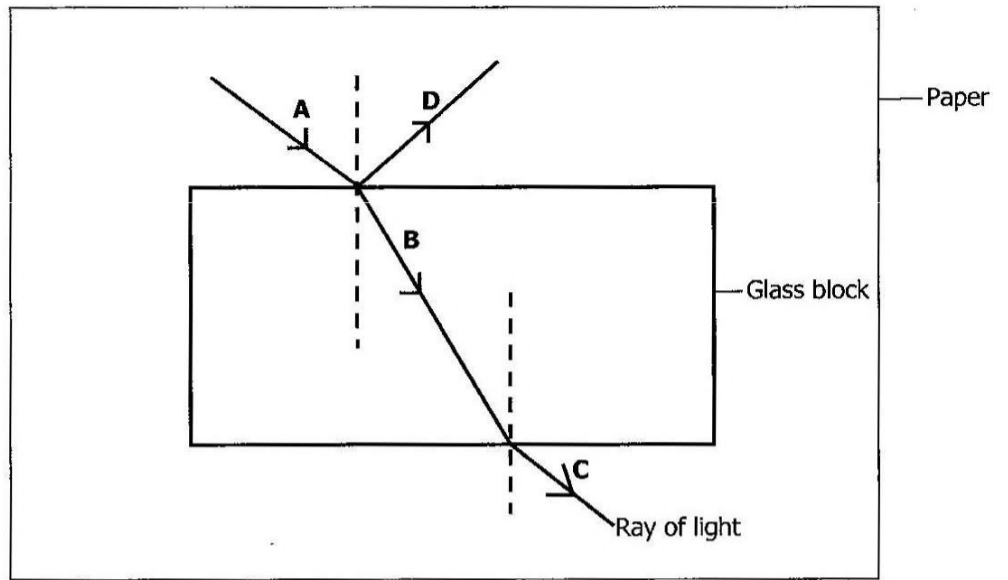

Figure 7.1

(a) Name the rays labelled A to D

- A
- B
- C
- D [2]

(b) On the diagram, indicate i and r for angles of incidence and refraction respectively. [1]

(c) For a certain piece of glass block the angle of incidence was found to be 25° and angle of refraction was found to be 16° . Using this information, Calculate the refractive index for this piece of glass block to two decimal places.

Refractive index [2]

[Total:5]

- 8 **Figure 8.1** shows a metal bar placed inside a vertical solenoid, above a small pile of iron nails.

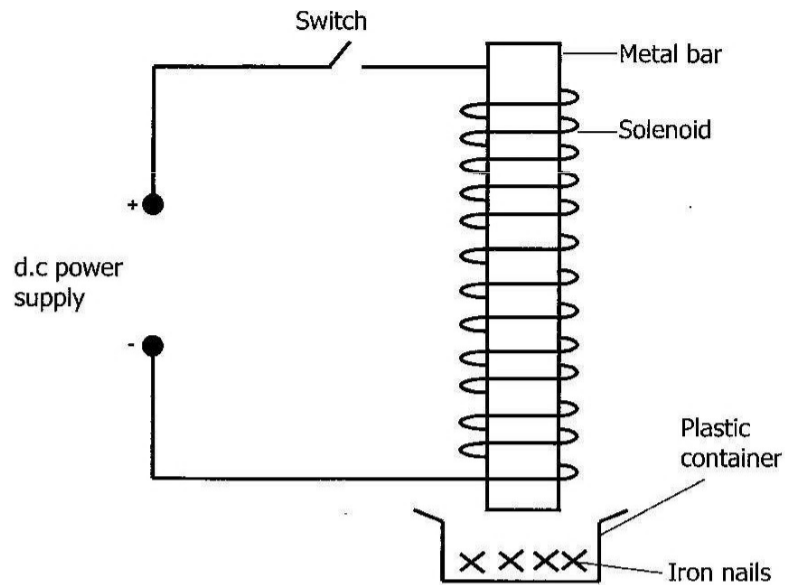

Figure 8.1

Describe the behaviour of the iron nails when the switch above is on for several seconds, then off, if the metal is made from ...

- (i) Aluminium
 [1]
- (ii) Iron.....
 [2]
- (iii) Steel
 [2]

[Total:5]

- 9 **Figure 9.1** shows a stream of α , β and γ rays passed through a uniform electric field represented by tracks **A**, **B** and **C**.

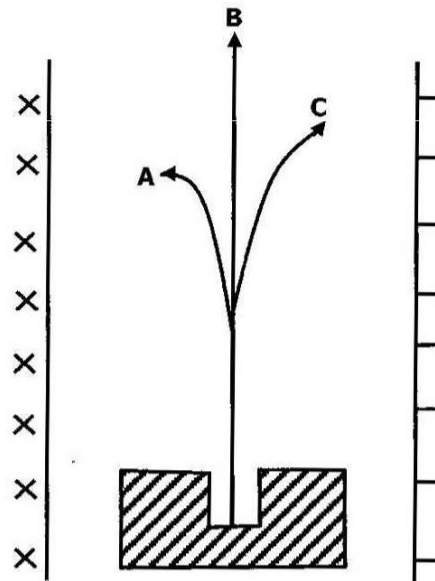

Figure 9.1

- (a) Identify the tracks marked **A**, **B** and **C** representing the radiations.

.....
 [1]

- (b) What is the charge for the radiation represented by the track marked **B**?

..... [1]

- (c) Thorium nucleus undergoes alpha-decay by emitting one particle to form a daughter element whose symbol is Rn.

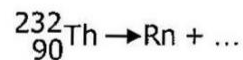

Complete the equation above that represent the decay of the Thorium nucleus; include the nucleon and proton numbers of the particles concerned.

[2]

[Total:4]

Section B

[20 marks]

Answer any **two (2)** questions from this section.Use the **Answer Booklet** provided.

- 10 (a)** State two effects that a simple machine can do to make work easier for man. [2]
- (b)** Explain why the efficiency of a simple machine
- (i)** is normally less than 100% [1]
- (ii)** Cannot exceed 100%. [1]
- (c)** Draw a labelled diagram to show a block and tackle pulley system of velocity ratio 4. [2]
- (d)** John uses the machine in 10(c) to raise a 60N load from the ground to a distance of 0.4m. The effort used by John to do the work is 20N. Calculate:
- (i)** the mechanical advantage and [2]
- (ii)** Efficiency of the machine [2]

[Total:10]

- 11 (a)** Distinguish between transverse and longitudinal waves. Include one example of each type of wave. [2]
- (b)** Describe an experiment to show reflection of water waves. [5]
- (c)** **Figure 11.1** shows a displacement-time graph for a water wave moving in the direction x .

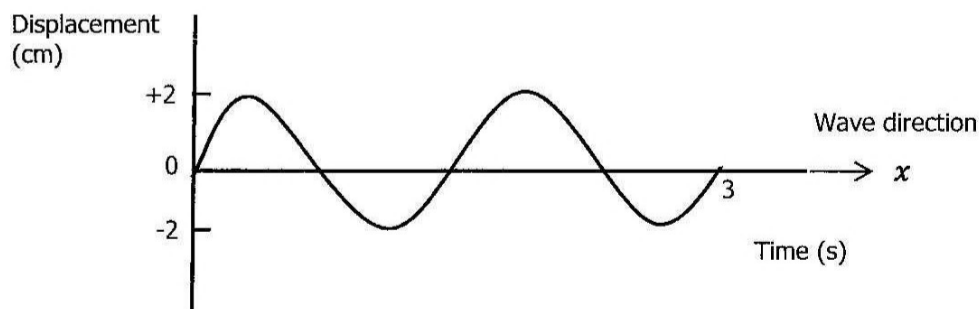
**Figure 11.1**

- (i)** State the period of the wave [1]
- (ii)** If the speed of the water wave is 0.2m/s, calculate the wavelength. [2]

[Total:10]

12 (a) State the difference between 'Electric charge and electric current'. [1]

(b) Below is a table of results obtained from an experiment to determine the relationship between the voltage and current through a metallic conductor.

Voltage (V)	0	2	4	6	8	10	12
Current (A)	0	0.5	1.0	1.5	2.0	2.5	3.0

(i) Plot a graph of voltage against current [3]

(ii) Calculate the resistance of the metallic conductor [2]

(c) Figure 12.1 shows 4Ω and 6Ω resistors connected in parallel.

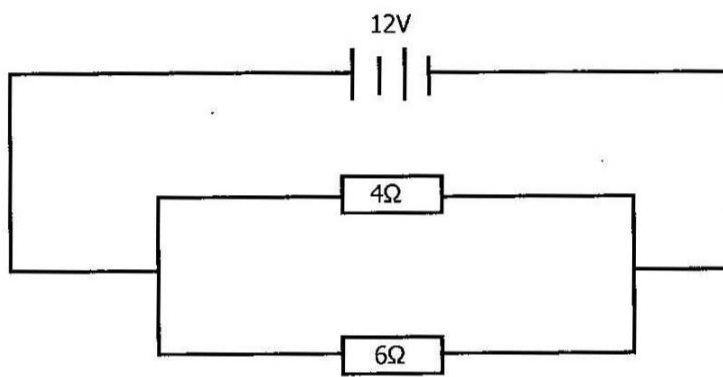

Figure 12.1

(i) Find the effective resistance [2]

(ii) Determine the current in the circuit. [2]

[Total:10]