

Centre Number				Examination Number									

EXAMINATIONS COUNCIL OF ZAMBIA



5124-1-050-921

Examination for General Certificate of Education Ordinary Level

Science

5124/1

Paper 1

2021

Additional Information:

- Electronic calculator (non programmable) and / or Mathematical tables
- Graph paper
- Soft clean eraser
- Soft pencil (type B or HB is recommended)

Time: 2 hours

Marks: 85

Instructions to Candidates

1 Write the **centre number** and your **examination number** on every page of this question paper and on the separate Answer Booklet/Paper provided.

2 There are **three** sections in this paper:

(i) Section A

There are **twenty** questions in this section. Answer **all** questions. For each question, there are four possible answers, **A, B, C** and **D**. Choose the best one and mark it with a cross (X) on the **answer grid provided** in this question paper.

(ii) Section B

Answer **all** questions. Write your answers in the **spaces provided** in this question paper.

(iii) Section C

Answer any **two** questions. Write your answers on a separate **Answer Booklet/Paper provided**.

Candidate's Use	Examiner's Use
Section A	
Section B	
Section C	1
	2
	3
Total	

Information for candidates

1 Any rough working should be done in this question paper.

2 At the end of the examination:

(i) Fasten the separate Answer Booklet/Papers used securely to the question paper.

(ii) Circle the numbers of the section **C** questions you have answered in the grid below.

3 Cell phones are **not allowed** in the examination room.

Centre Number				Examination Number									

A3 A student weighed a small amount of sugar crystals and found the mass to be 0.568g. After adding two small sugar crystals, the mass was found to be 0.571g. Assuming that the sugar crystals were identical, what was the average mass of one crystal?

- A $1.5 \times 10^{-3} \text{g}$
- B $1.5 \times 10^3 \text{g}$
- C $3.0 \times 10^{-3} \text{g}$
- D $3.0 \times 10^3 \text{g}$

A4 The following graph shows how distance varies with time for a cyclist's ride that lasted for 250 seconds.

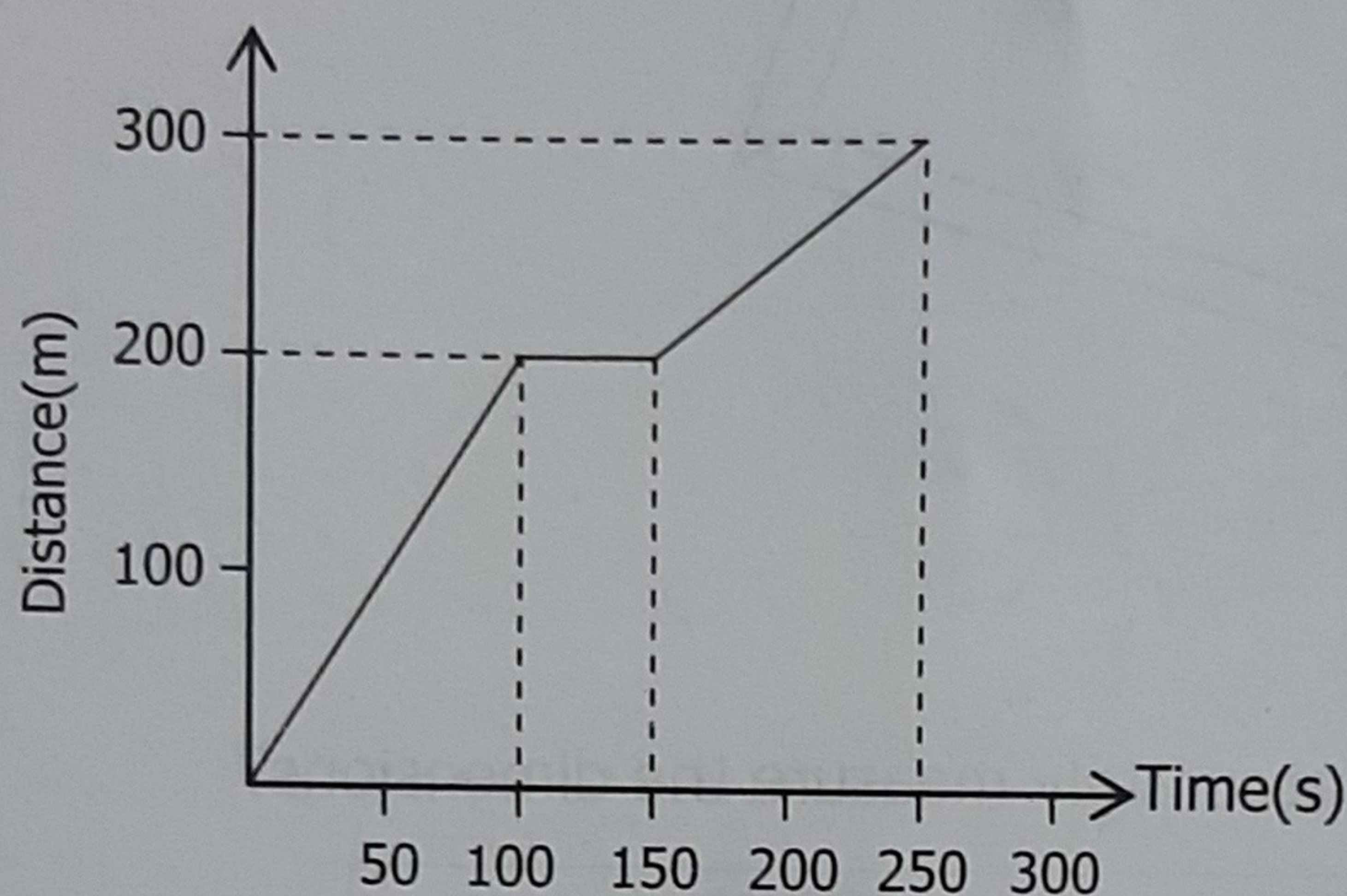

What is the cyclist's average speed for the whole journey?

- A 1.0m/s
- B 1.2m/s
- C 1.5m/s
- D 2.0m/s

A5 The diagram shows a car going around a bend at a constant speed.

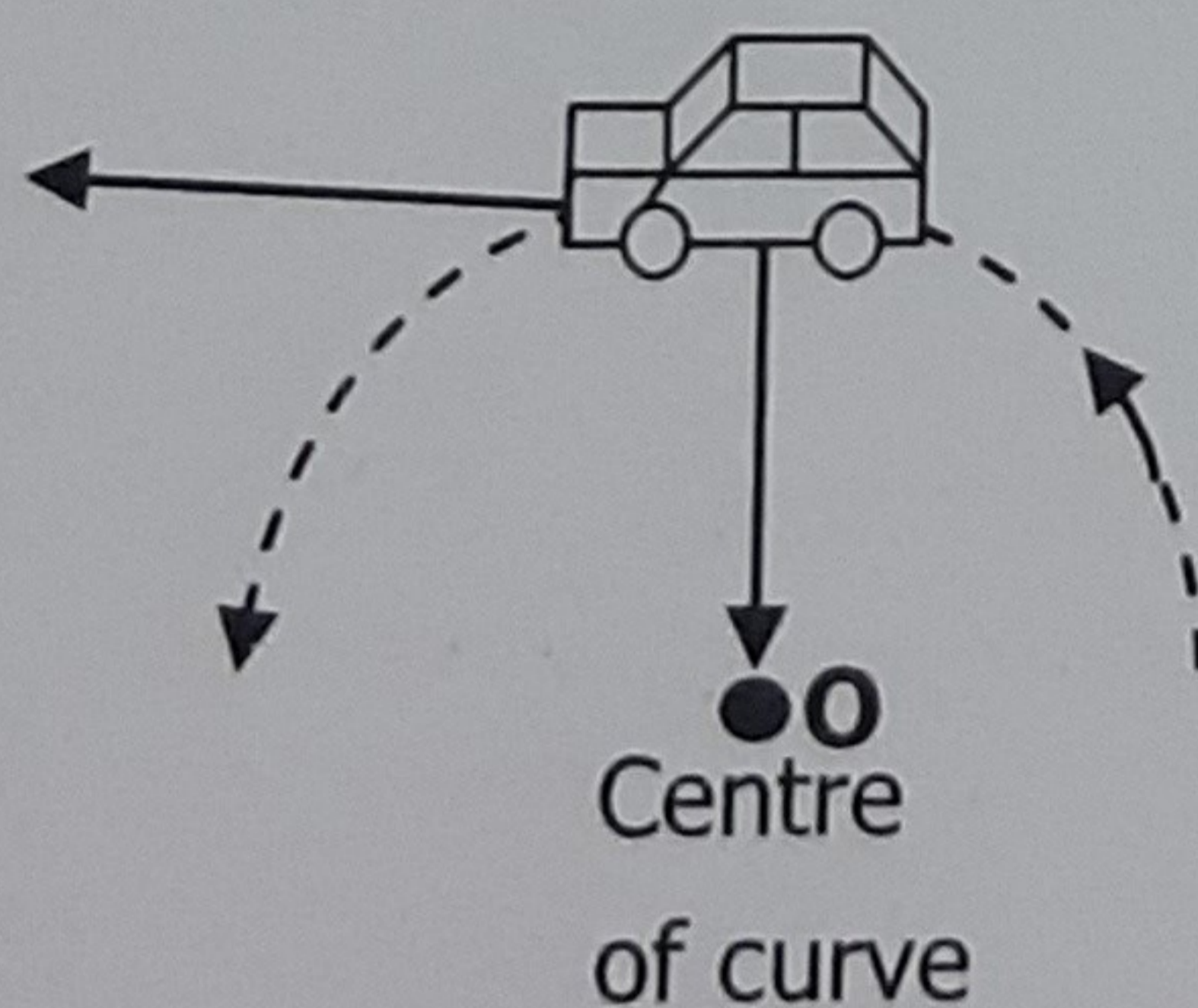

Which statement about the car is correct?

- A There is no resultant force acting on the car.
- B The car is not accelerating.
- C A force of constant size acts on the car towards the centre of the curve, **O**.
- D A force of constant size acts on the car in the direction of motion.

A6 In a small hydroelectric power station, 20kg of water flows through a vertical height of 15m in one second. If the efficiency of the power station is 60% and taking 'g' as 10N/kg, what is the power output of the hydroelectric power station?

- A 180W
- B 1 800W
- C 3 000W
- D 18 000W

A7 The following diagram shows 4 identical metal cans **E, F, G, H** whose outside surfaces were painted as indicated. Equal volumes of water at a temperature of 80°C were placed in the cans.

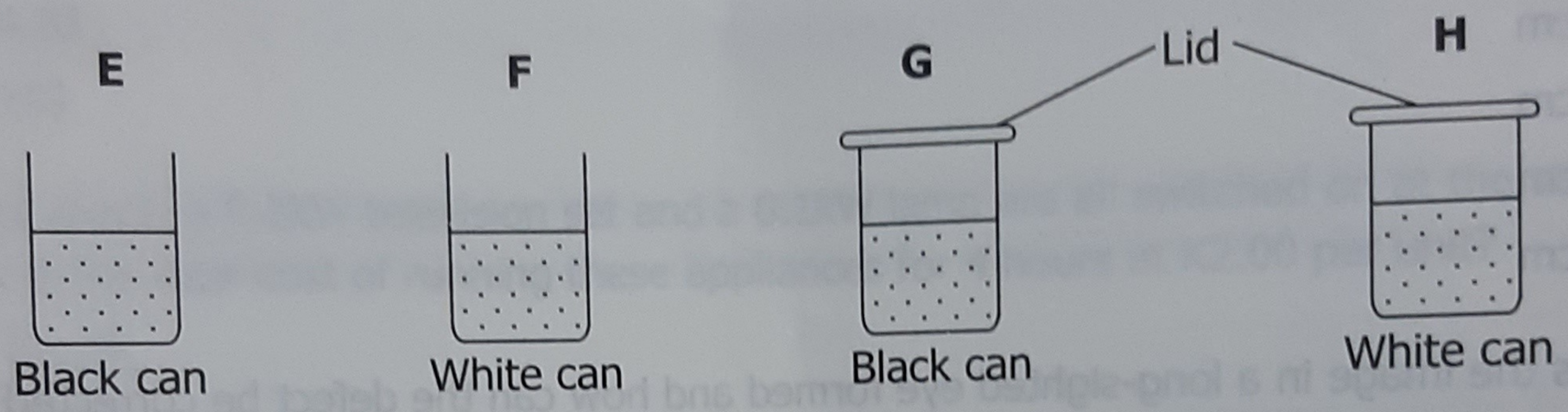

After 5 minutes in a cool room, which metal can would contain the coolest water?

- A E
- B F
- C G
- D H

A8 A crest of a water wave travels 0.4m in 5 seconds. If the distance between two successive crests is 0.005m, what is the frequency of the wave?

- A 0.2Hz
- B 1.6Hz
- C 8.0Hz
- D 16.0Hz

A9 An echo-sounder in an aeroplane receives an echo from the ground 20 seconds after it was sent. If the speed of sound in air is 330m/s, how high is the plane above the ground?

- A 16.5m
- B 33m
- C 660m
- D 3 300m

A14 The diagram shows a resistor connected to a cell of e.m.f 2V.

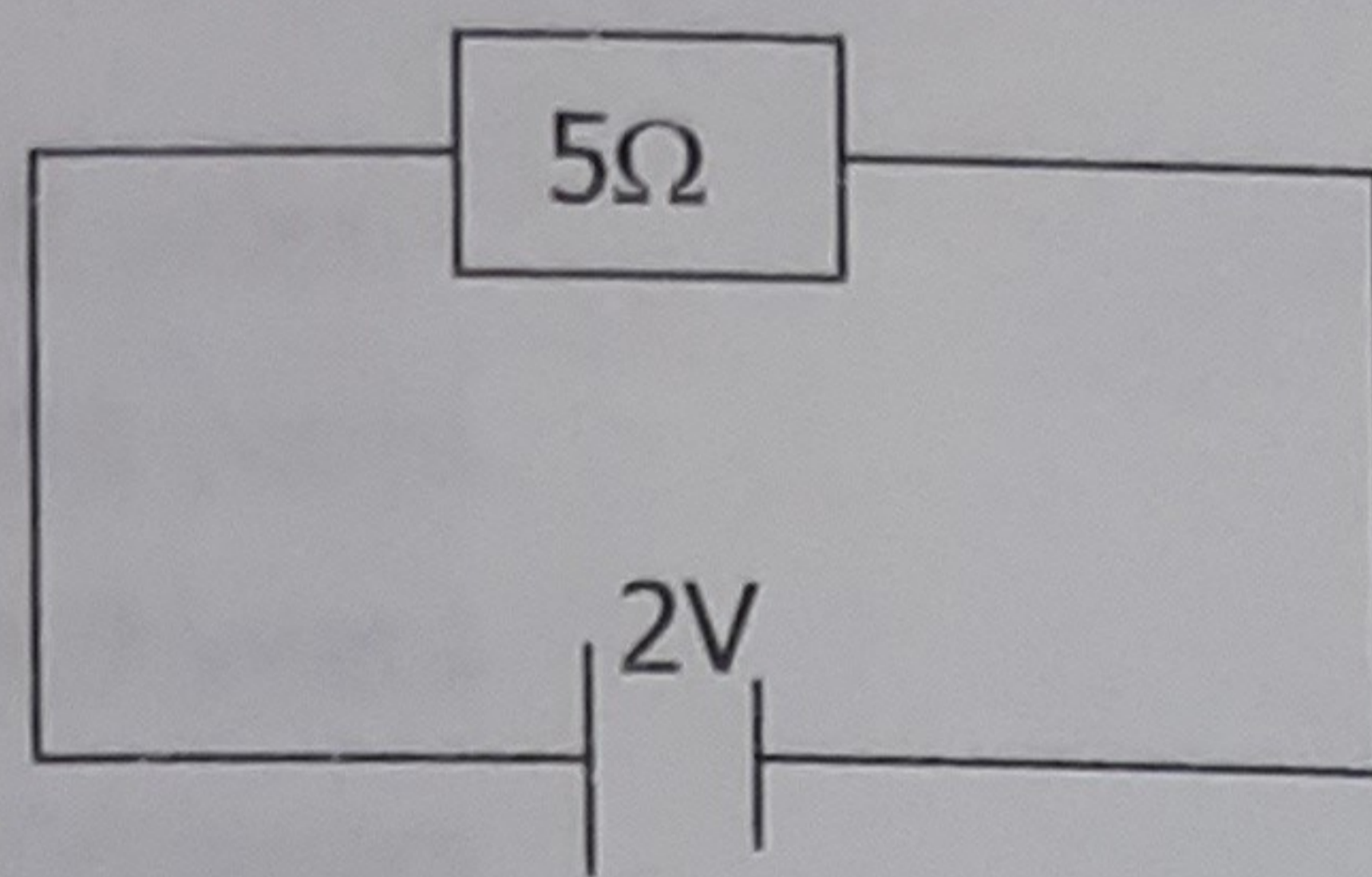

How much heat energy is produced in the resistor in 6 seconds?

- A** 0.4J
- B** 2.5J
- C** 4.8J
- D** 10J

A15 A 2kW stove, a 0.2kW television set and a 0.1kW lamp are all switched on at the same time. What is the total cost of running these appliances for 4 hours at K2.00 per unit?

- A** K1.74
- B** K4.60
- C** K9.20
- D** K18.40

A16 A small coil is connected to a galvanometer as shown.

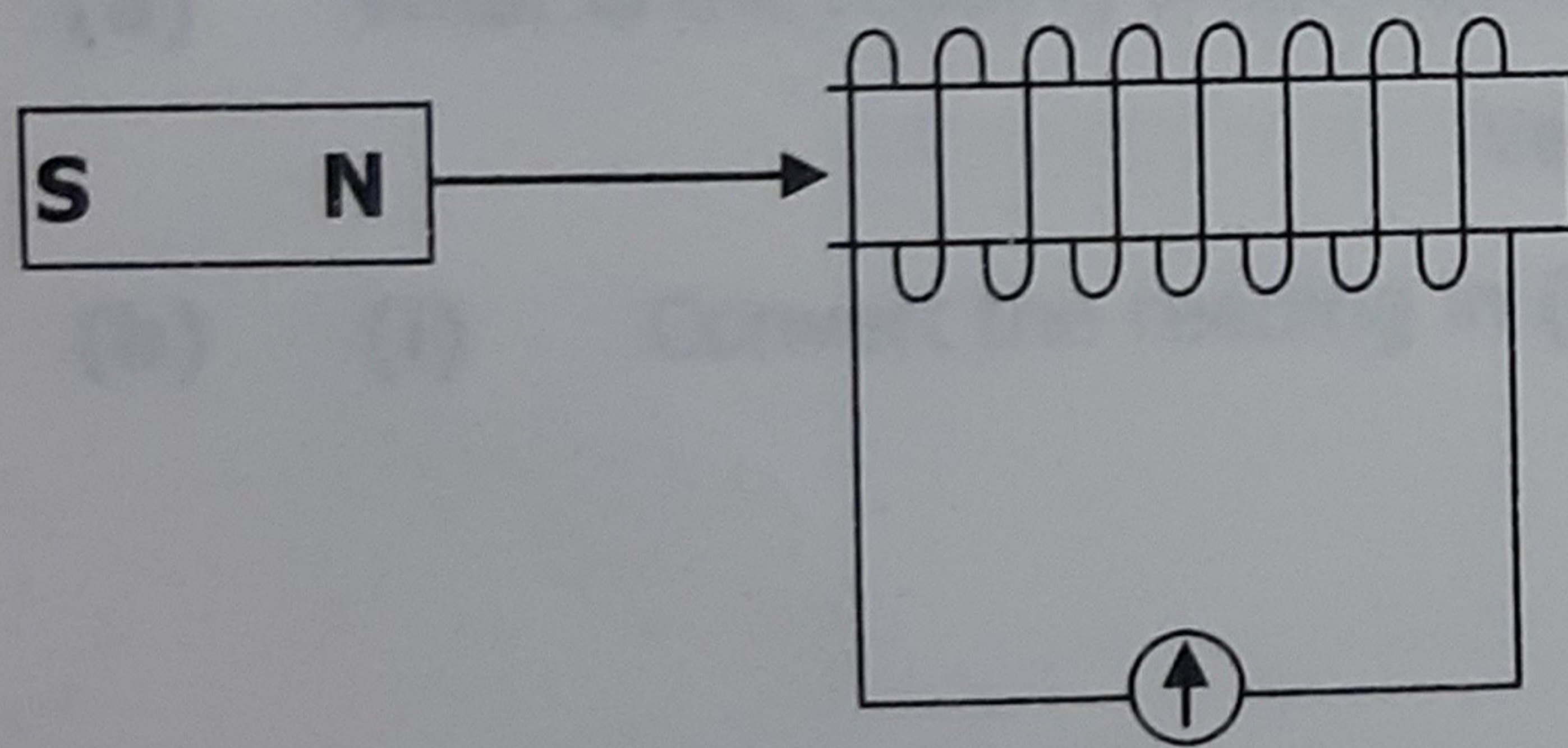

What happens to the pointer of the meter when the magnet is pushed into the coil? The pointer ...

- A** deflects to the left and then returns to zero.
- B** deflects to the right and then returns to zero.
- C** gives a continuous reading to the left.
- D** gives a continuous reading to the right.

Centre Number				Examination Number									

A17 Which graph shows the voltage output **V** against time **t** for an a.c generator?

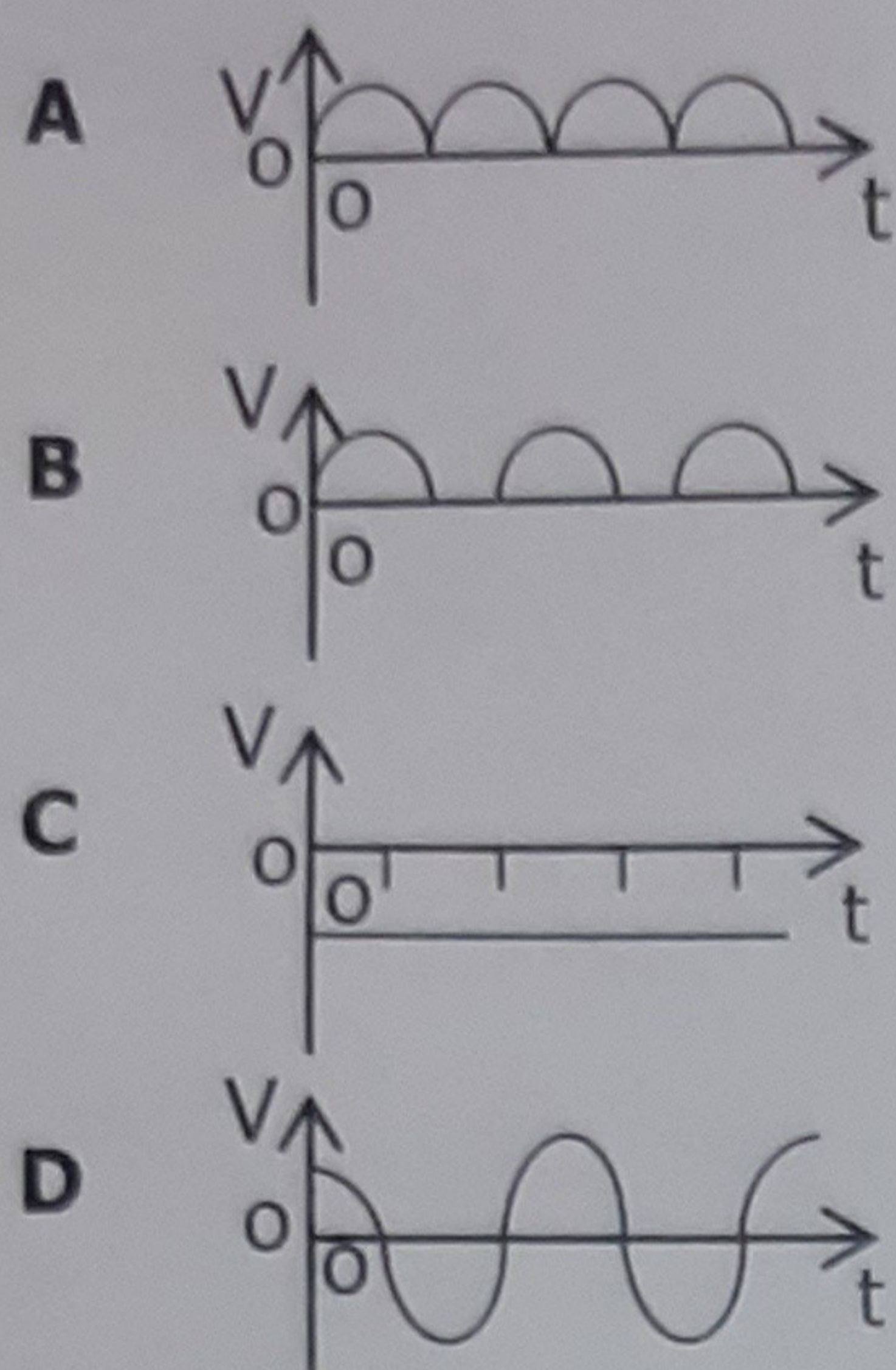

A18 The following diagram shows the appearance on the screen of the alternating voltage applied to the input of an oscilloscope. The sensitivity is set to 3 volts per cm.

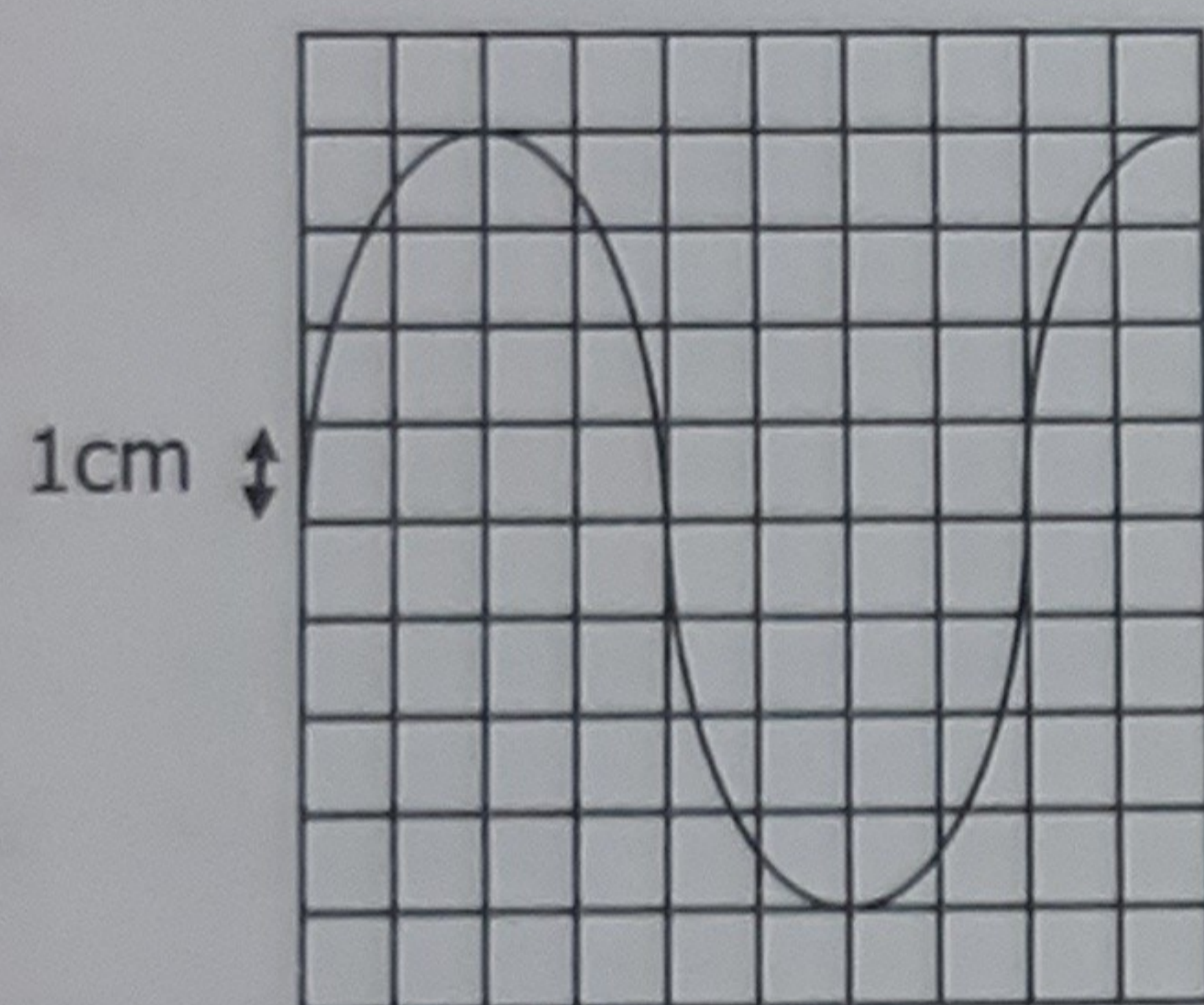

What is the maximum voltage?

- A 1V
- B 3V
- C 4V
- D 12V

A19 Radioactive iodine is used to treat tumours of the thyroid gland. It decays by emitting beta particles and gamma radiation. The beta decay process is represented by the following equation:

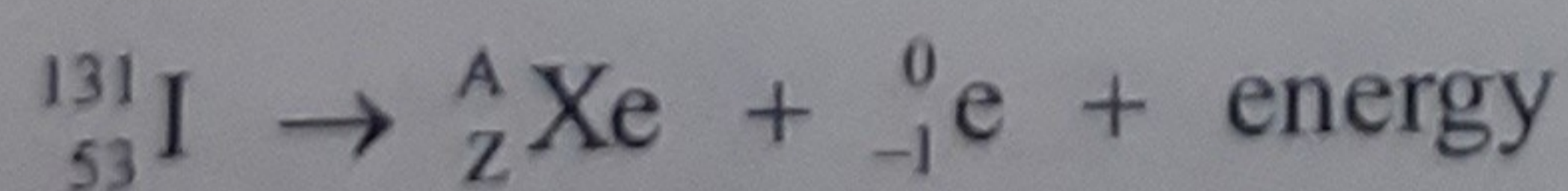

What is the nucleon number, **A**, and proton number, **Z**, for this nucleus of Xe?

	Nucleon number	Proton number
A	78	53
B	130	55
C	131	54
D	184	78

Centre Number				Examination Number																

- A20** A radioactive isotope has a half life of 6 000 years. How much time passes before the rate of emission from a sample of this isotope falls to $\frac{1}{16}$ of the original value?
- A** 6 000 years
 - B** 18 000 years
 - C** 24 000 years
 - D** 96 000 years

Section B [45 marks]

Answer **all** questions in this section. Write your answers in the spaces provided in this question paper.

- B1** **Figure B1.1** is a diagram showing the reading of the Vernier callipers.

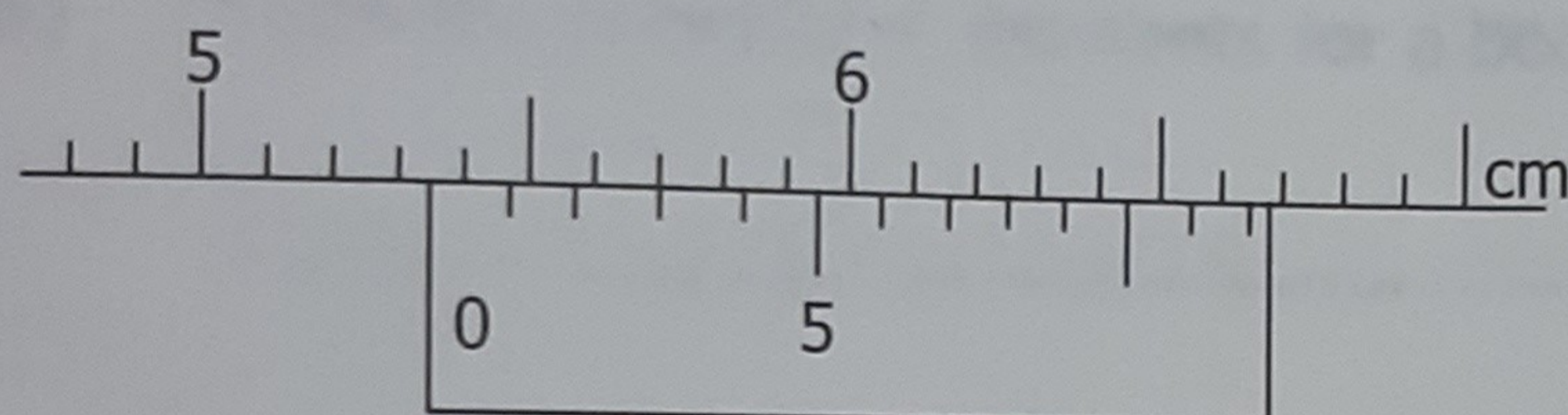

Figure B1.1

- (a)** What is the reading shown on the Vernier callipers?
 Vernier callipers reading: [2]

- (b) (i)** Convert the reading in **(a)** above to metres.

Vernier callipers reading in metres: [2]

- (ii)** Write the reading in **(b)(i)** in standard notation.
 [1]

- (iii)** How many significant figures does the Vernier callipers reading in metres have?
 [1]

[Total: 6 marks]

Centre Number				Examination Number																

B2 A man of mass 75kg on earth goes to the moon where the gravitational field strength is 1.6N/kg.

(a) What is the mass of the man on the moon?

Mass [1]

(b) What is the weight of the man on the moon?

Weight [2]

(c) A light truck of mass 2 000kg accelerates from rest at a rate of 1.5m/s^2 . Calculate the force required to accelerate the car at this rate.

Force [2]

[Total: 5 marks]

B3 Figure B3.1 is a diagram showing a uniform metre rule freely pivoted at its centre. A newton meter is hung 20cm from the pivot while a 4.0N weight is suspended 40cm from the pivot.

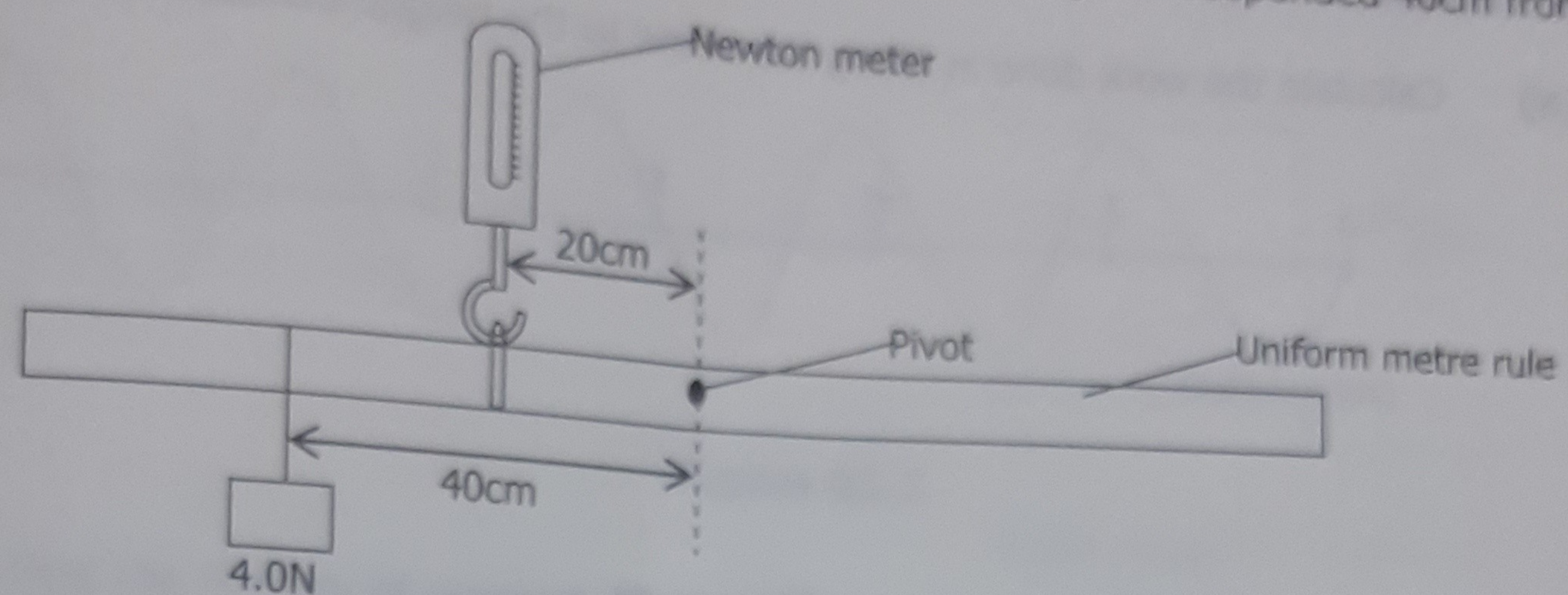

Figure B3.1

The metre rule is in equilibrium.

(a) State the principle of moments for a body in equilibrium.

.....
 [1]

(b) Calculate the reading on the newton meter.

Reading [2]

(c) State with a reason whether the newton meter reading would increase or decrease when the 4.0N weight is moved to a distance of 30cm away from the pivot.

.....
 [2]

[Total: 5 marks]

Centre Number				Examination Number			

B4 A small hard ball of mass 0.14kg is thrown vertically upwards and reaches a height of 12m above the point from which it is thrown.

(a) Calculate the work done in lifting the stone to the height it attains.

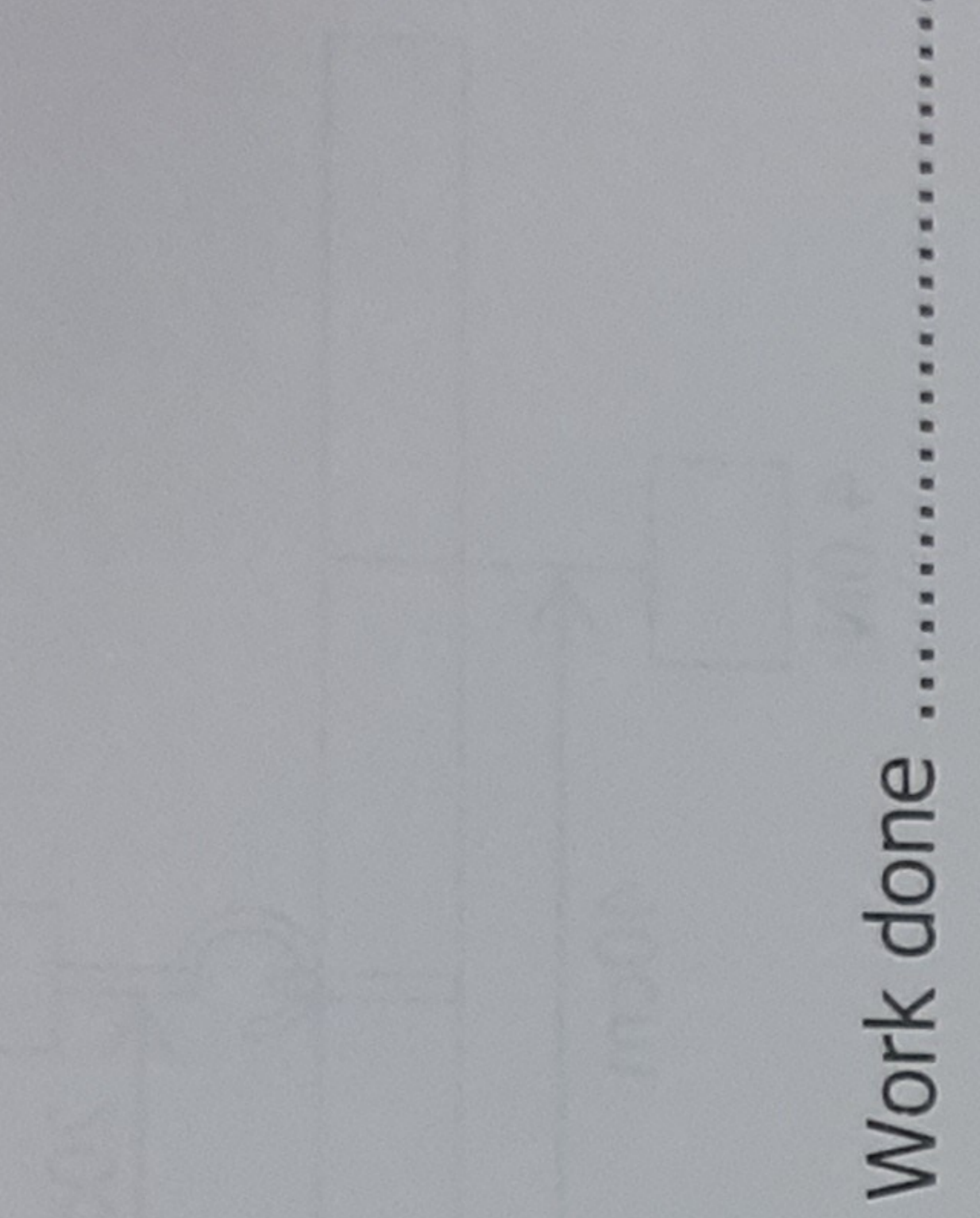

Work done [2]

(b) What is the velocity of the ball at the maximum height?

Velocity [1]

(c) On a windy day the same stone is thrown upwards with the same energy, but fails to reach the height reached earlier. Why does it happen like this?

.....

[Total: 5 marks]

Centre Number				Examination Number									

B5 Figure B5.1 shows transverse waves.

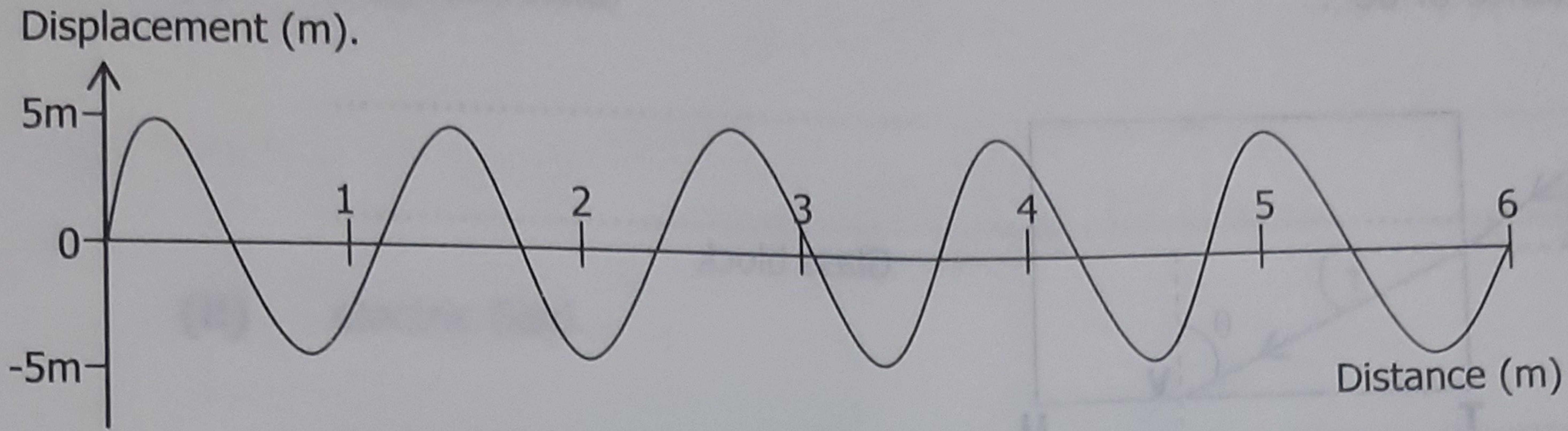

Figure B5.1

(a) Find the number of waves in Figure B5.1

Waves..... [1]

(b) What is the amplitude of the waves generated in the figure above?

Amplitude..... [1]

(c) Calculate the speed of the waves above if the number of waves in Figure B5.1 are produced in 2 seconds.

Speed [2]

[Total: 4 marks]

Centre Number		Examination Number			

B6 Figure B6.1 shows light in air striking the vertical side of a rectangular glass block at an angle of incidence of 60° .

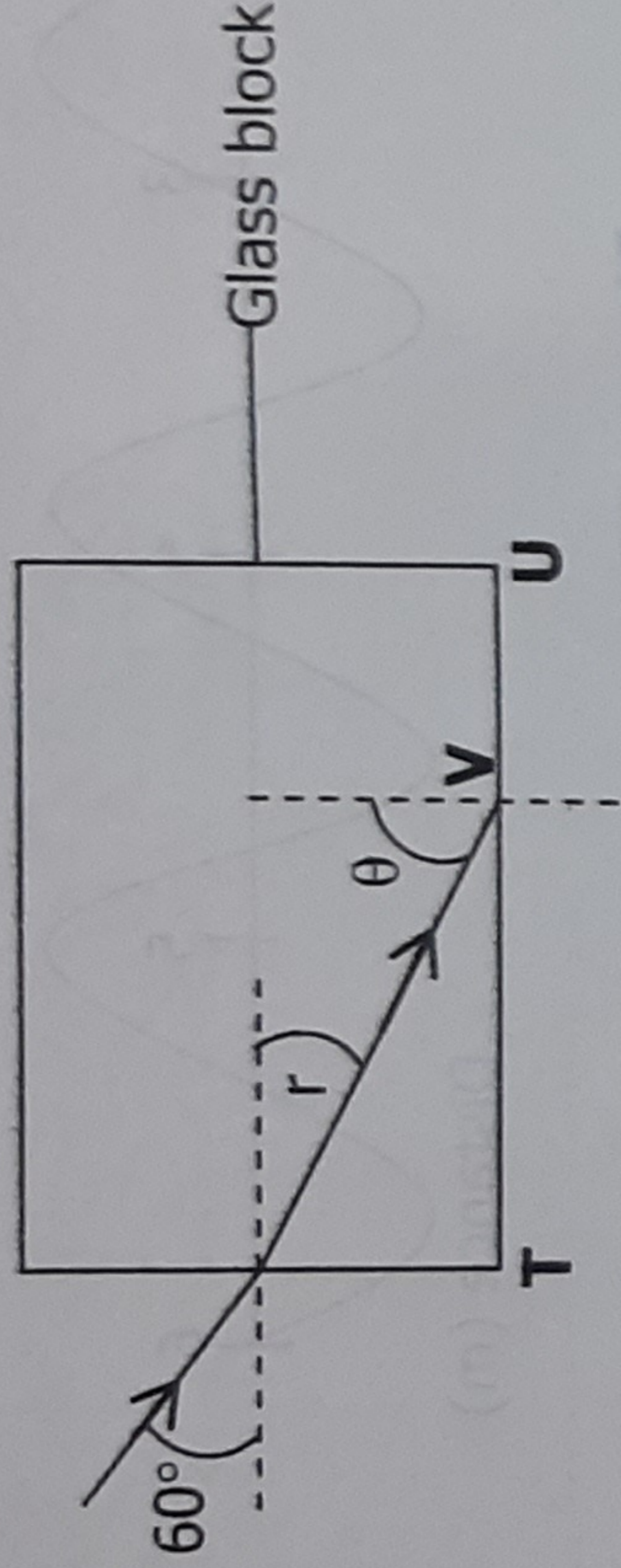

Figure B6.1

The refractive index of glass is 1.6.

(a) What is refractive index?

.....
 [1]

(b) **(i)** Calculate the angle of refraction, r .

(ii) What is the critical angle of the glass block?
 Angle r [2]

Critical angle [2]

[Total: 5 marks]

Centre Number				Examination Number																	

B7 (a) Explain what is meant by
(i) magnetic field,

.....

[1]

(ii) electric field.

.....

[1]

(b) Complete the diagram in **Figure B7.1 (b)** to show the pattern and direction of the magnetic field lines in the space around the bar magnet.

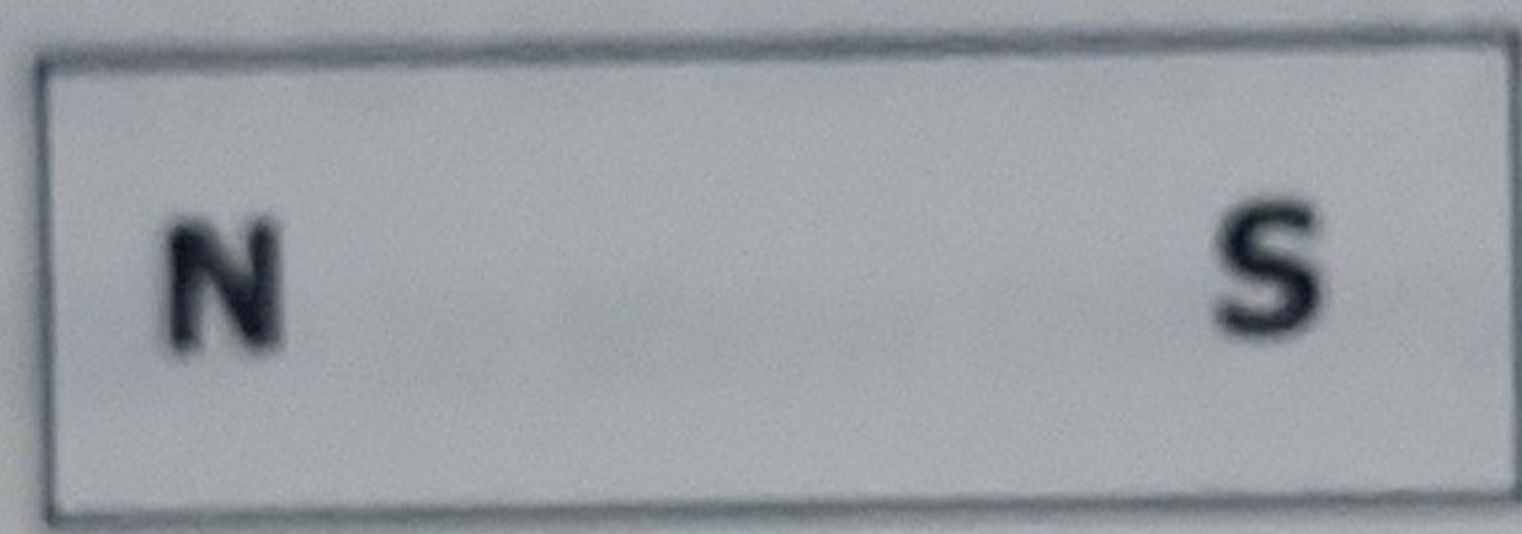

Figure B7.1 (b)

[2]

(c) **Figure B7.1 (c)** shows a positively charged sphere **S** placed near to an initially uncharged isolated conductor **AB**. Complete the diagram to show the charges induced in the diagram.

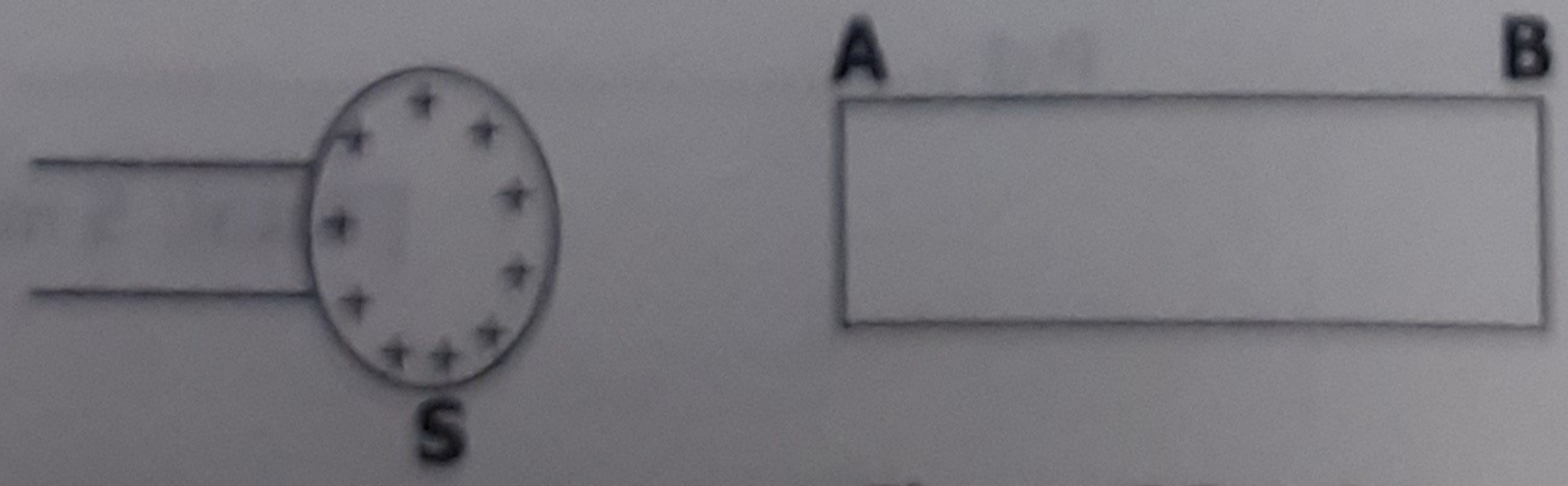

Figure B7.1 (c)

[1]

Centre Number				Examination Number									

B8 Figure B8.1 shows an electrical circuit containing two resistors.

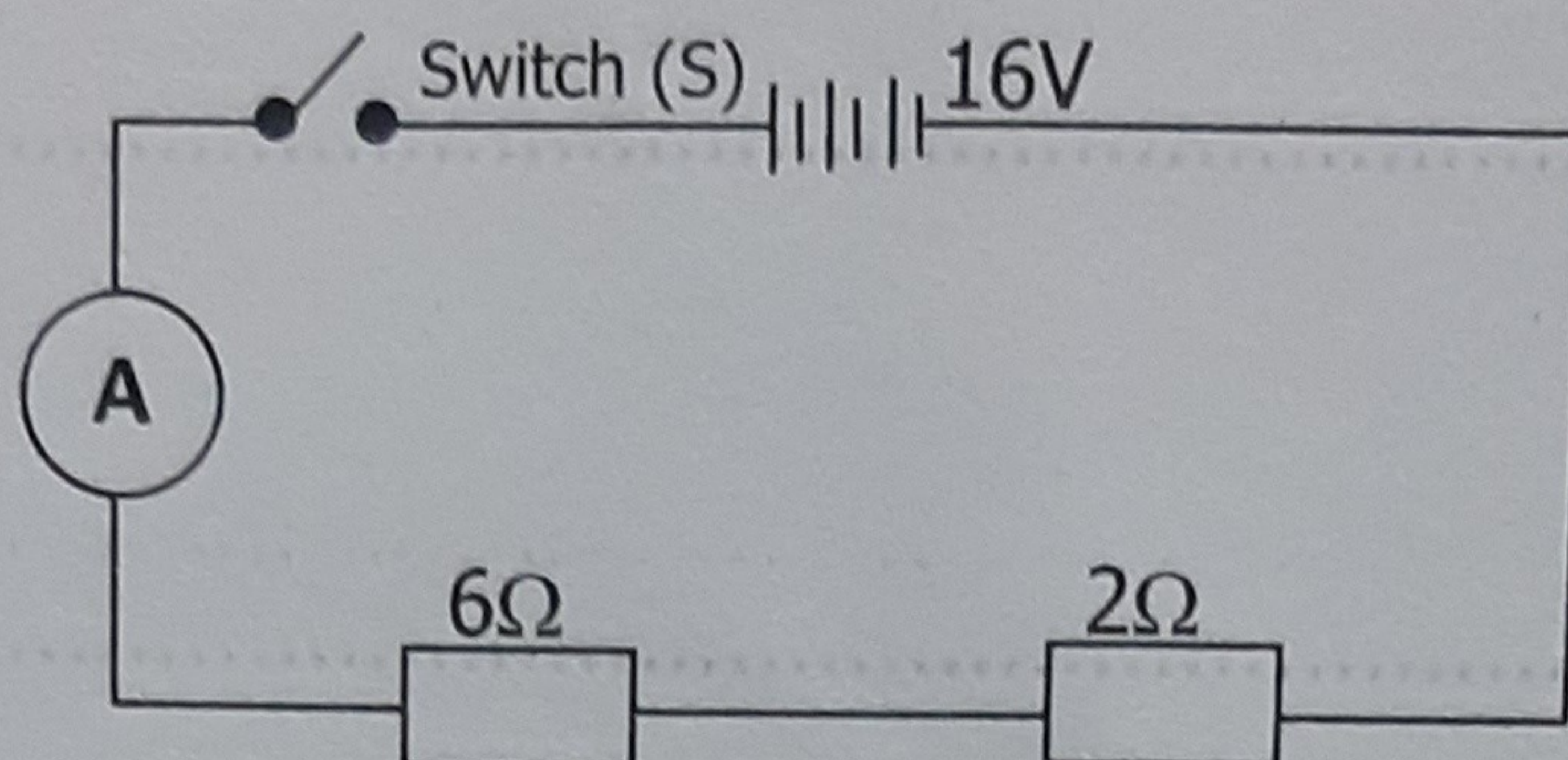
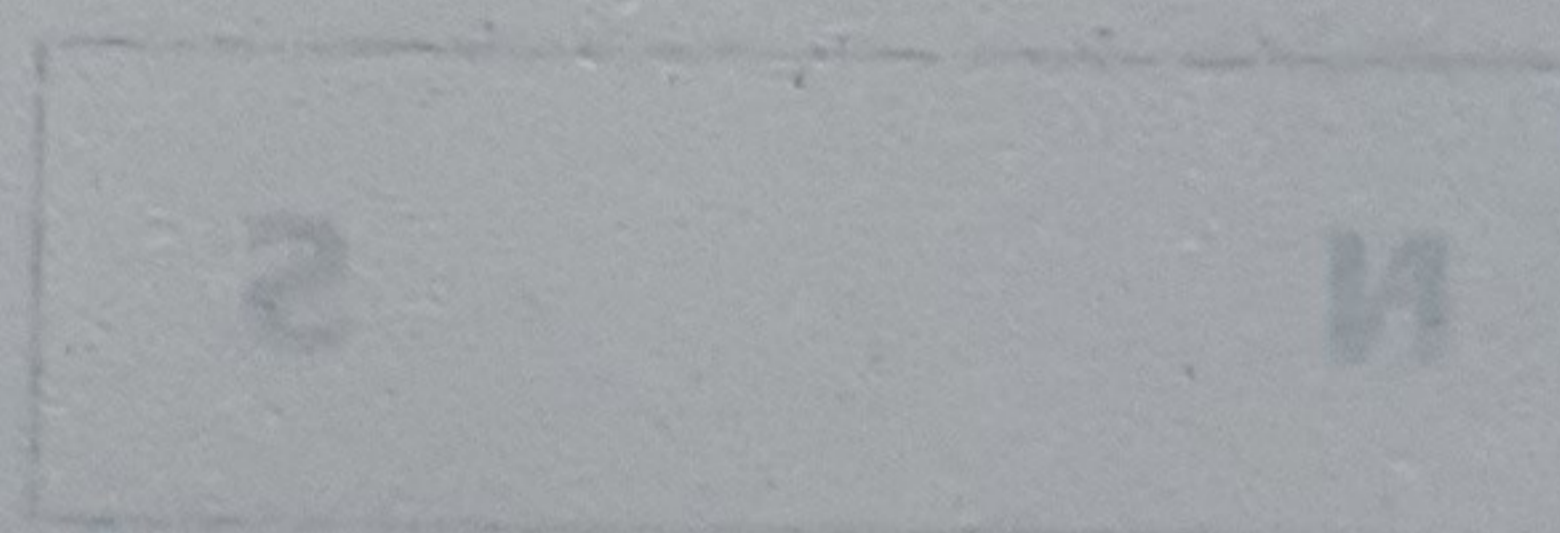

Figure B8.1

- (a) On **Figure B8.1**, draw on the circuit to show how a voltmeter will be used to measure the potential difference across the 6Ω resistor. [1]
- (b) When the switch **S** is closed, calculate the current through the ammeter, **A**.



Current [2]

- (c) What is the potential difference across the 6Ω resistor?

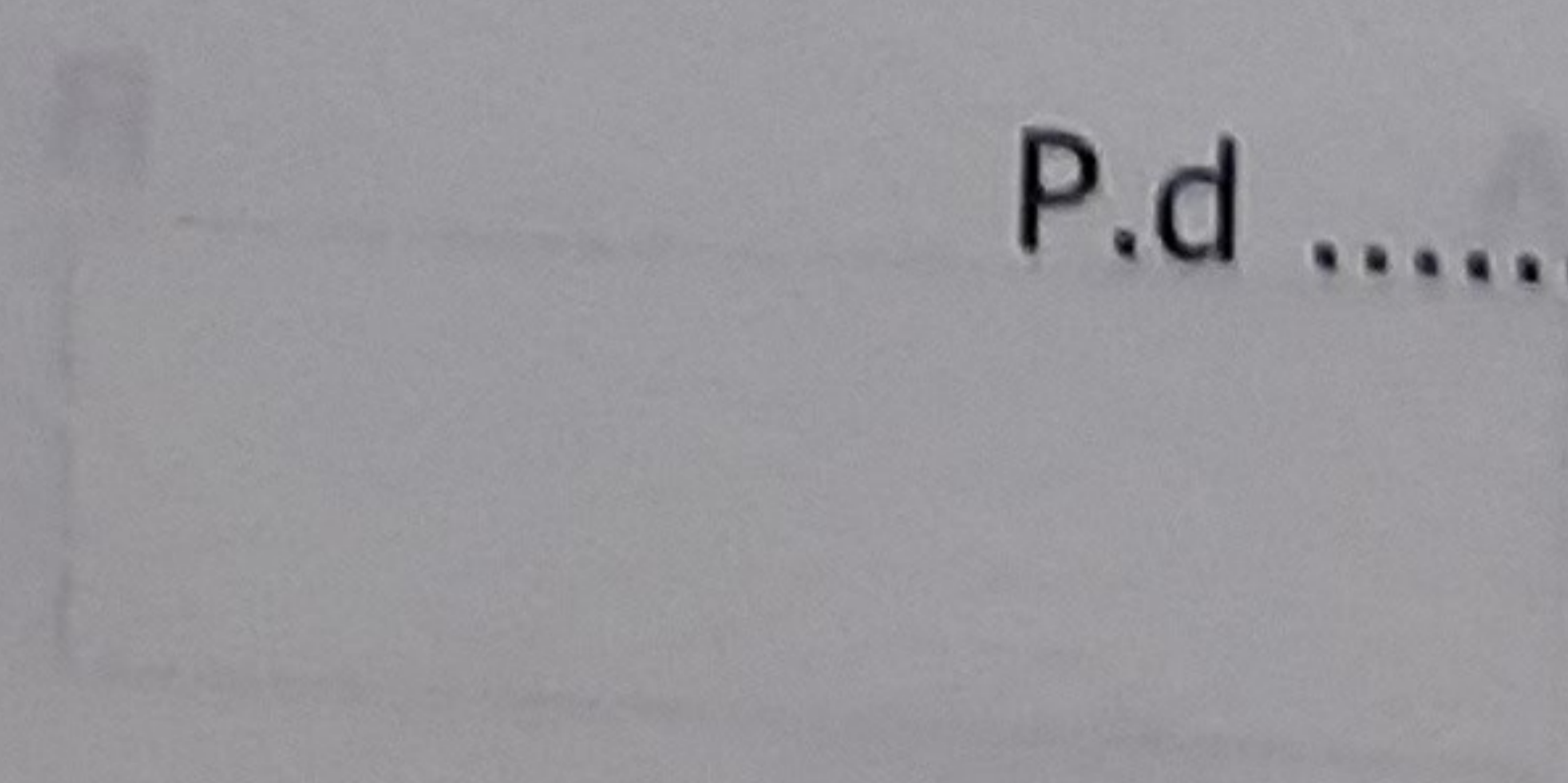

[Total: 5 marks]

Centre Number				Examination Number									

B9 Uranium ${}_{92}^{238}\text{U}$ decays to form a nucleus of thorium by emission of an alpha particle. Thorium has the symbol ${}_{90}^{234}\text{Th}$.

(a) What is the meaning of nucleon number?

.....

[1]

(b) Write a decay equation to show how uranium ${}_{92}^{238}\text{U}$ decays to thorium ${}_{90}^{234}\text{Th}$ after emitting an alpha particle.

[2]

(c) Thorium, ${}_{90}^{234}\text{Th}$, decays to an isotope of protactinium, Pa, by beta decay. Write the decay equation to show this process.

[2]

[Total: 5 marks]

Centre Number				Examination Number									

SECTION C [20 marks]

Answer any **two** questions from this section in the separate Answer Booklet provided.

C1 Figure C1.1 shows a conveyor belt driven by an electric motor carrying suitcases into a trailer of a truck.

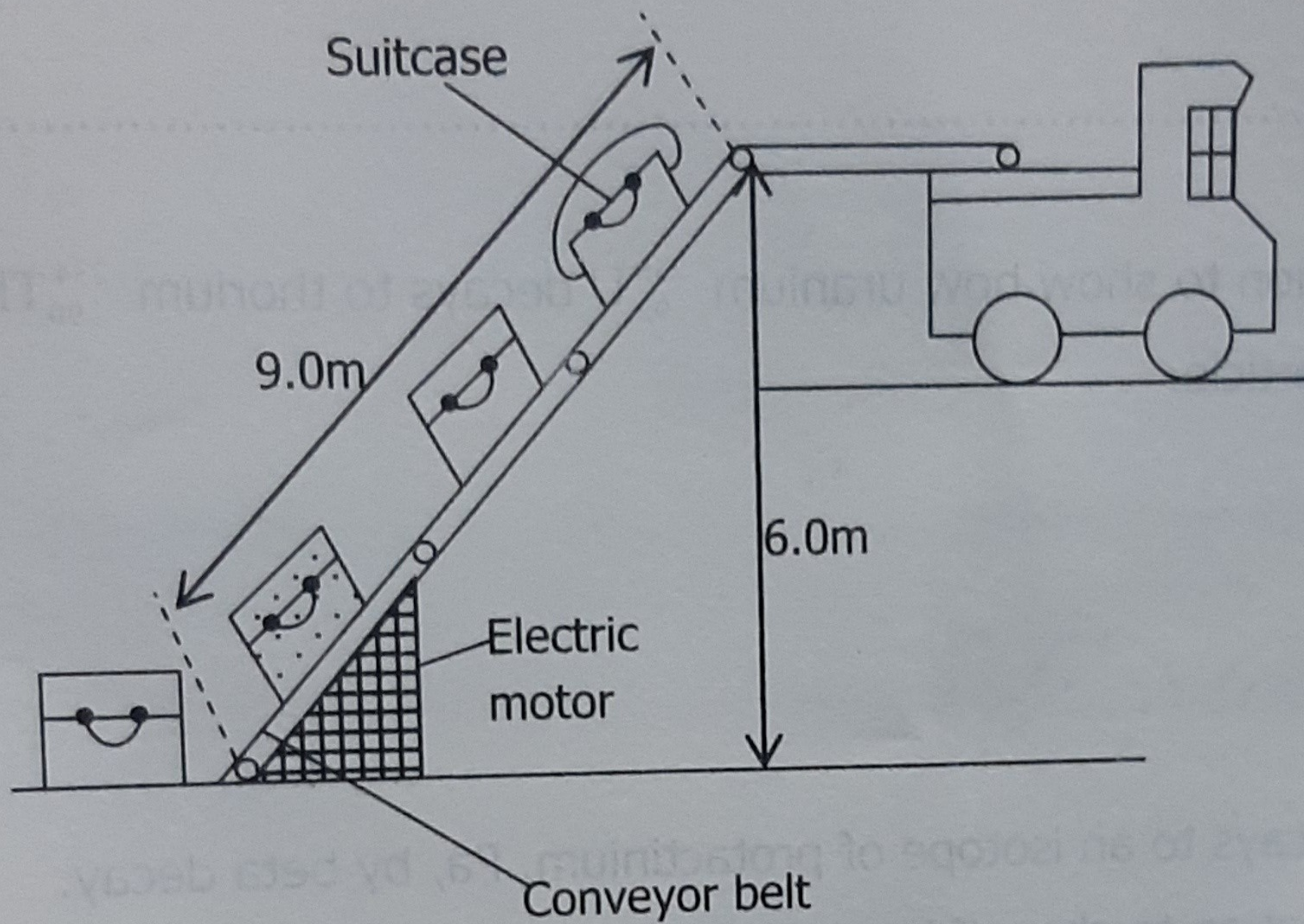

Figure C1.1

- (a) Give **two** differences between mass and weight. [2]
- (b) If a suitcase of mass 20kg is lifted from the ground to the truck. Taking 'g' as 10N/kg, calculate the
 - (i) weight of the suitcase, [2]
 - (ii) gravitational potential energy of the suitcase at the top of the conveyor as it enters the truck. [2]
- (c) The suitcase takes 12 seconds to travel 9.0m along the conveyor belt. Calculate the power of the motor. [2]
- (d) The electric motor is powered by an input voltage of 230V and current of 1.5A. Calculate the electrical energy input to the motor in 12 seconds. [2]

[Total: 10 Marks]

Centre Number	Examination Number

The **Figure C2.1** shows a square block of glass **JKLM** with a ray of light incident on side **JK** at an angle of incidence of 60° . The refractive index of the glass is 1.50.

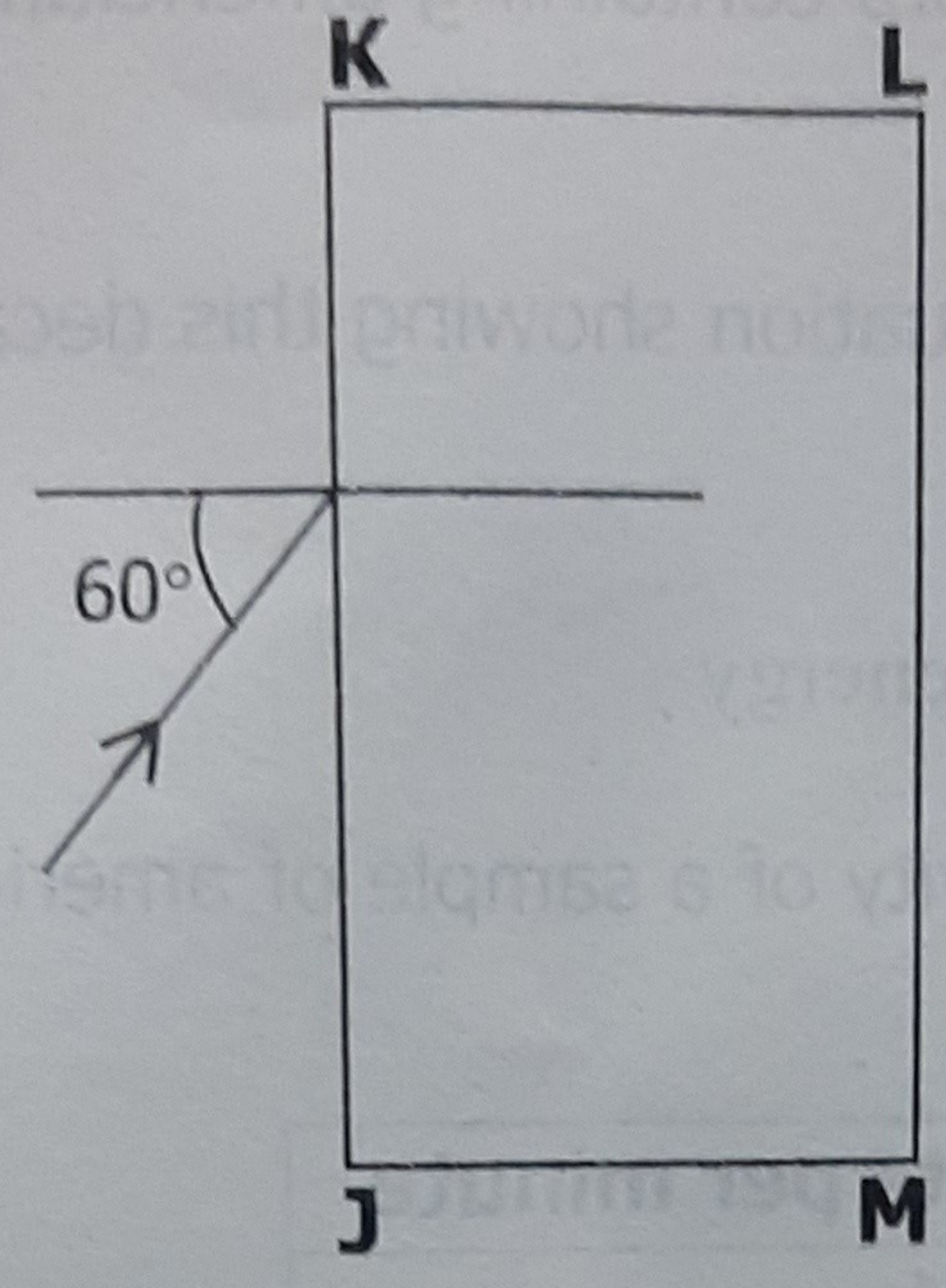

Figure C2.1

- (a) Calculate the angle of refraction of the ray. [2]
- (b) Calculate the critical angle for a ray of light in this glass. [2]
- (c) Explain why the ray shown cannot emerge from **KL** but will emerge from side **LM**. [2]
- (d) Diamond has a refractive index of 2.42. The speed of light in a vacuum (or in air) is 300 000km/s.
Calculate the
 - (i) speed of light in diamond, [2]
 - (ii) critical angle for diamond. [2]

[Total: 10 Marks]

Centre Number				Examination Number															

C3 The atomic number of americium-241 is 95. Americium-241 decays by losing an alpha particle.

(a) (i) Explain why smoke detectors containing americium-241 are not harmful to people. [1]

(ii) Copy and complete the equation showing this decay by giving values for X and Y.



(b) **Figure C3.1** shows how the activity of a sample of americium-241 changes over a long period of time.

Time/years	Activity/counts per minute
0	64
500	30
1 000	14
1 500	6
2 000	2

Figure C3.1

(i) Use these numbers to draw a graph of activity against time for americium-241. [4]

(ii) Use your graph to find the half-life of americium-241. [1]

(c) Californium-241 is also radioactive and decays by losing an alpha particle. It has a half-life of 4 minutes. Suggest why it would be unsuitable for use in a smoke detector. [2]

[Total: 10 Marks]