

EXAMINATIONS COUNCIL OF ZAMBIA

Joint Examination for the School Certificate
and General Certificate of Education Ordinary Level

SCIENCE **(CHEMISTRY, PHYSICS)** PAPER 1 Multiple Choice

5124/1

Tuesday

6 NOVEMBER 2012

Additional materials:

Mathematical tables

Multiple Choice Answer Sheet

Soft clean eraser

Soft pencil (types B or HB is recommended)

Time: 1 hour

INSTRUCTIONS TO CANDIDATES

Do not open this booklet until you are told to do so.

Look at the left hand side of your answer sheet. Ensure that your name, the school/centre name and subject paper are **printed**. Also ensure that the subject code, paper number, centre code, your examination number and the year are **printed and shaded**. Do not change the already printed information.

There are **forty questions** in this paper. Answer **all** questions. For each question, there are **four possible answers, A, B, C and D**. Choose the one you consider correct and record your choice in soft pencil on the separate answer sheet.

Read very carefully the instructions on the answer sheet.

INFORMATION FOR CANDIDATES

Each correct answer will score one mark. A mark will not be deducted for a wrong answer. Any rough working should be done in this question paper.

The **Periodic Table** is printed on page 13.

Cell phones are not allowed in the Examination Room.



- 1 The diagram shows part of a vernier calliper used to measure the width of a rectangular glass block.

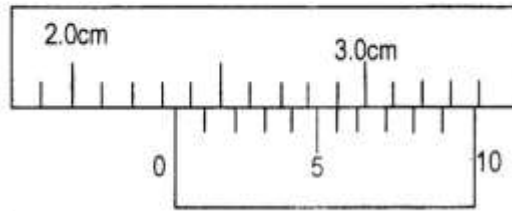

The correct reading is ...

- A 1.46 cm.
B 2.25 cm.
C 2.36 cm.
D 2.54 cm.
- 2 Which of the following represents an SI unit?

Name	Symbol
------	--------

- | | |
|--------------|----|
| A gram | g |
| B second | s |
| C centimetre | cm |
| D kilojoule | KJ |

- 3 Which of the following graphs represents an increasing velocity?

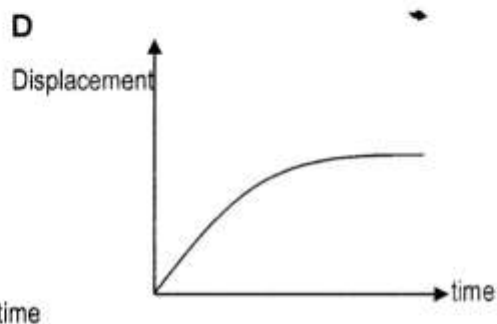
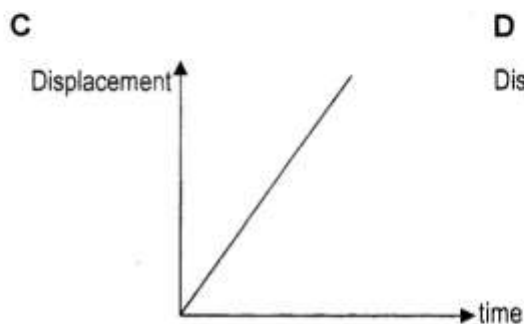
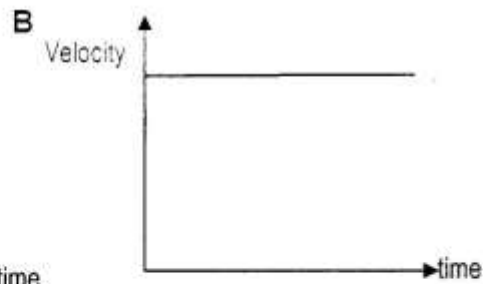
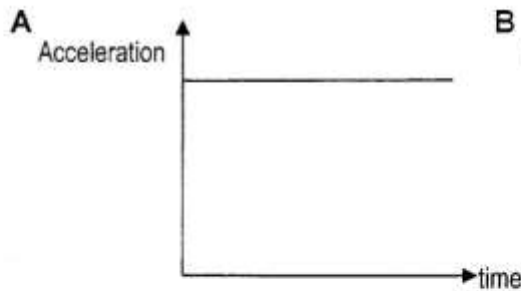

- 4 The diagram below shows a cross-section through the centre of a triangular prism. **M** is the position of the centre of Mass of the prism.

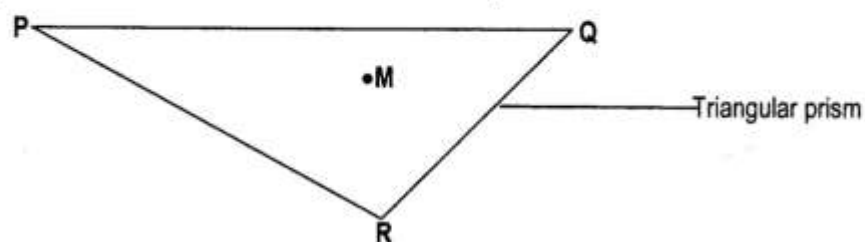

PQ may be considered to have maximum stability because ...

- A it has the greatest contact base area.
 - B it is above **M** and far away from **R**.
 - C the centre of mass **M** is furthest from point **P**.
 - D the centre of mass **M** has the greatest vertical height at this base.
- 5 The graph below was obtained by a pupil in a physics experiment to investigate the effects of forces on a spring.

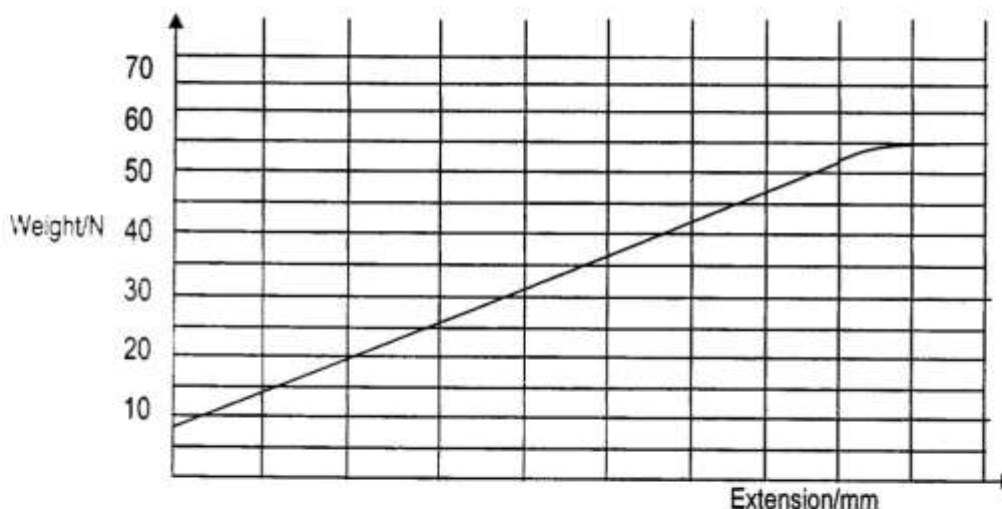

What is the approximate value of the force required to start pulling the turns of the spring away from each other?

- A 5.0N
 - B 7.5N
 - C 10.0N
 - D 15.0N
- 6 A person exerts a horizontal force of 500N on a box, which also experiences a friction force of 100N.

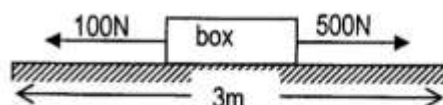

How much work is done against friction when the box moves a horizontal distance of 3m?

- A 1800J
- B 1500J
- C 1200J
- D 300J

7 The diagram shows an ideal system of pulleys.

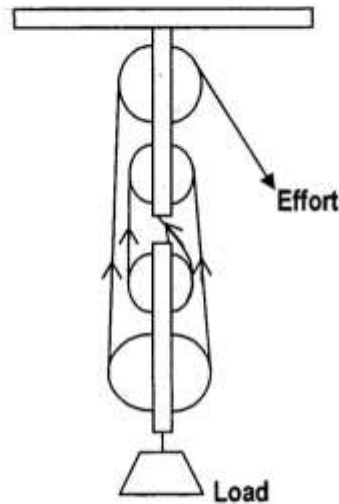

The Mechanical advantage of the system is ...

- A 6
 - B 5
 - C 4
 - D 2
- 8 Heat travels in a solid by conduction. Heat flows from one end of a solid to the other by the...
- A flow of electrons and convection currents.
 - B flow of electrons and movement of atoms.
 - C vibration of atoms and convection currents.
 - D vibration of atoms and flow of electrons.
- 9 The diagram shows a thermocouple thermometer.

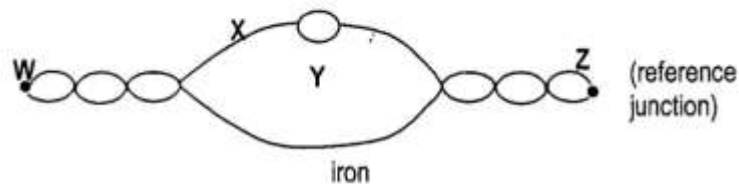

Which of the following is true?

- A Side W is the cold junction.
- B Material X is made of iron.
- C The letter Y represents a thermometer.
- D The instrument is calibrated at boiling point of water.

10 The diagram below represents a sound wave.

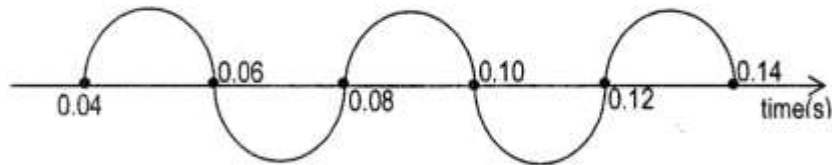

In a space of 120cm there are ten compressions and ten rarefactions. What is the speed of the sound wave?

- A 150cm/s
- B 300cm/s
- C 340cm/s
- D 350cm/s

11 The diagram shows a sound wave reflected from a brick wall.

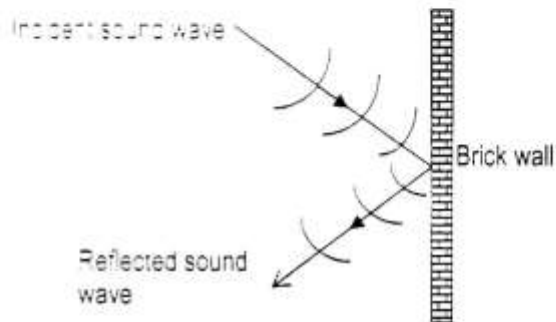
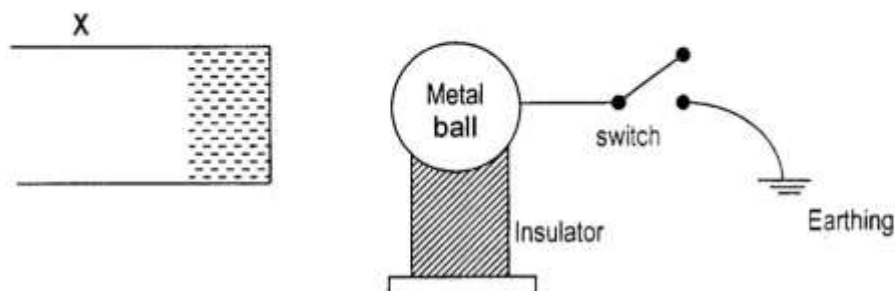

Figure 11.1

Compared with the incident wave, the reflected wave has ...

- A a greater amplitude.
 - B a shorter wavelength.
 - C the same speed.
 - D the same velocity.
- 12 Which of the following is a property of magnetic field lines?
- A They run from south pole to north pole.
 - B They cross each other at the poles.
 - C They run from north pole to the south pole.
 - D Magnetic field is weak when they are close.

- 13 The diagram below shows an experimental set up on electrostatics.



When the switch is closed ...

- A protons flow from the metal ball to the ground.
 - B electrons flow from the metal ball to the ground.
 - C protons flow from the ground to the metal ball.
 - D electrons flow from the ground to the metal ball.
- 14 The instrument commonly used for measuring the charge which is passing per second is ...
- A an ammeter.
 - B a voltmeter.
 - C a cathode ray oscilloscope.
 - D a gold leaf electroscope.
- 15 The figure below shows a circuit diagram.

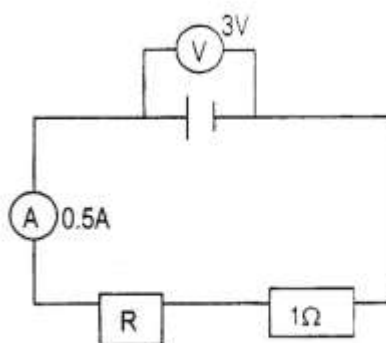

The value of the resistor R is ...

- A 0.5Ω
 - B 1.5Ω
 - C 5.0Ω
 - D 6.0Ω
- 16 What is the cost of running a 750W electric fan for 4 hours and a 2KW heater for 2 hours if electric energy costs K150 per KWh?
- A K500
 - B K650
 - C K700
 - D K1,050

- 17 The diagram below shows a transformer used in a laboratory during an experiment.

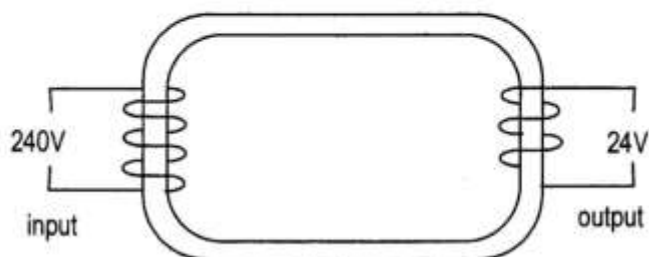

If 0.2A current flows through the input, the size of current given out at the output is ...

- A 0.1A
 B 0.2A
 C 2.0A
 D 10.0A
- 18 The brightness of a spot of light on a CRO screen may be changed by varying the potential difference across the ...
- A X-plates.
 B Y-plates.
 C Control grid.
 D glass envelope.
- 19 The table shows the possible properties of radioactive emissions. Which emission represents an alpha particle?

Emission	Charged	Deflected in magnetic field	Ionising effect
A	Yes	Yes	Weak
B	Yes	No	Weak
C	No	Yes	None
D	No	Yes	None

- 20 In a fission reactor, which particle causes a Uranium-235 nucleus to split?
- A Proton
 B Neutron
 C Gamma ray
 D Alpha particle
- 21 Which of the following is **not** one of the basic units of matter?
- A Atom
 B Ion
 C Nucleus
 D Molecule

- 22 Which of the following can be used to measure a volume of 15.6cm^3 accurately?
- Burette
 - Pipette
 - Measuring cylinder
 - Volumetric flask
- 23 A condenser is used in distillation experiments to turn ...
- liquid into gas.
 - solid into liquid.
 - vapour into gas.
 - vapour into liquid.
- 24 The diagram below represents the structure of a certain elementary particle, P.

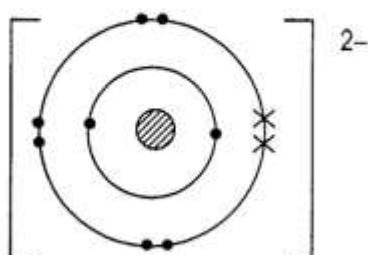

- Which of the following is **not** true about P?
- P is an oxide ion.
 - P is an isotope of magnesium.
 - P has a noble gas electronic structure.
 - P has 8 protons in its nucleus.
- 25 Element Q has atomic number 11 whereas element R has atomic number 8. The compound formed when atoms of Q and atoms of R react together ...
- will be a volatile liquid at r.t.p.
 - will be a crystalline solid at r.t.p.
 - contains diatomic molecules.
 - is soluble in organic solvents but insoluble in water.
- 26 The formula of lithium phosphate is Li_3PO_4 . What is the formula of magnesium phosphate?
- Mg_3PO_4
 - MgPO_4
 - $\text{Mg}_2(\text{PO}_4)_3$
 - $\text{Mg}_3(\text{PO}_4)_2$
- 27 What mass of calcium metal reacts completely with 9.0g of water according to the equation below?
- $$\text{Ca(s)} + 2\text{H}_2\text{O(l)} \longrightarrow \text{Ca(OH)}_2\text{(aq)} + \text{H}_2\text{(g)}$$
- 40g
 - 20g
 - 10g
 - 5.0g

32 What is the ionic equation for the neutralisation reaction between sodium hydroxide and sulphuric acid?

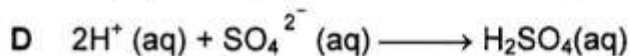
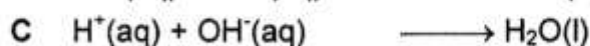
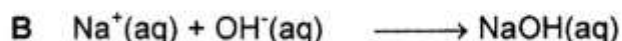
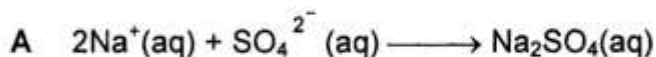

33 Which of the following oxides dissolves in both acid and alkali?

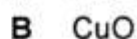

34 When ethanol vapour is passed over heated alumina, ethane is formed according to the equation below:

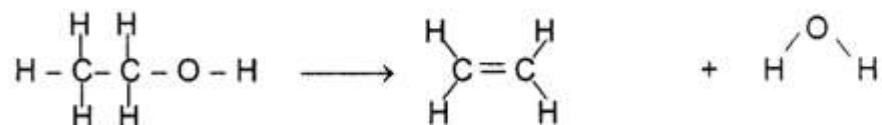

What term is used to describe the above reaction?

A Reduction

B Hydrolysis

C Substitution

D Dehydration

35 Which of the pairs of compounds represents isomers?

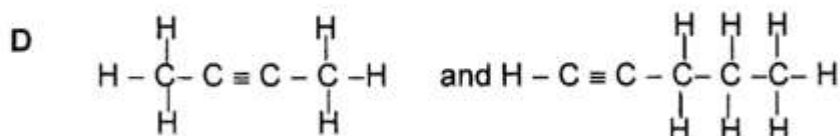
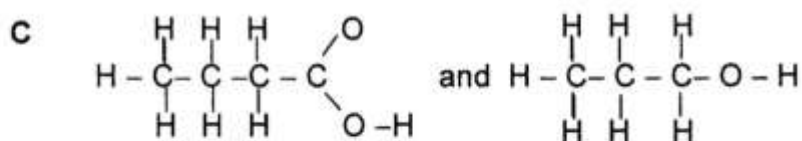
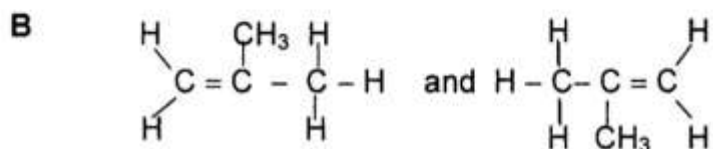
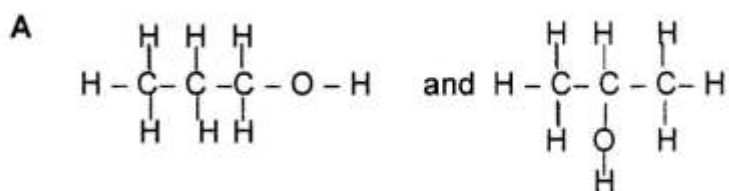

36 The structure below shows an addition polymer.

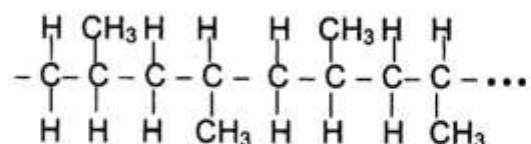

The monomer for the above polymer is ...

- A $\begin{array}{ccc} \text{H} & \text{H} & \text{H} \\ | & | & | \\ \text{H}-\text{C} & -\text{C} & -\text{C}-\text{H} \\ | & | & | \\ \text{H} & \text{H} & \text{H} \end{array}$
- B $\begin{array}{c} \text{H} & & \text{H} \\ & \diagdown & / \\ & \text{C} = \text{C} & -\text{C}-\text{H} \\ & / & | \\ \text{H} & & \text{H} \end{array}$
- C $\begin{array}{ccc} \text{H} & \text{CH}_3 & \\ | & | & \\ \text{H}-\text{C} & -\text{C}-\text{H} \\ | & | & \\ \text{H} & \text{H} & \end{array}$
- D $\begin{array}{ccc} \text{H} & & \text{CH}_3 \\ & \diagdown & / \\ & \text{C} = \text{C} & \\ & / & \diagdown \\ \text{CH}_3 & & \text{H} \end{array}$

37 Which of the compounds below is likely to be present in the petrol fraction?

- A C_3H_8
 B C_5H_4
 C $\text{C}_{12}\text{H}_{26}$
 D $\text{C}_{24}\text{H}_{50}$

38 In which of the following reactions is the underlined substance being oxidised?

- A CO_2 (g) + C(s) \longrightarrow 2CO(g)
 B MgO(s) + H_2SO_4 (aq) \longrightarrow MgSO_4 (aq) + H_2O (l)
 C HCl (g) + NaOH (aq) \longrightarrow H_2O (l) + NaCl(aq)
 D H_2O_2 (aq) + Ag_2O (s) \longrightarrow H_2O (l) + Ag(s) + O_2 (g)

39 Which of the following pollutant gases is the major cause of acid rain?

- A Nitrogen monoxide
 B Chlorofluorocarbons
 C Carbon monoxide
 D Sulphur dioxide

- 40 Ammonia is manufactured by the Haber Process using the reaction represented by the equation below.



What are the conditions of temperature and pressure which are used to obtain a satisfactory yield of ammonia?

	Temperature	Pressure
A	300°C	450atm.
B	500°C	250atm.
C	1000°C	20atm.
D	450°C	700atm.