

EXAMINATIONS COUNCIL OF ZAMBIA

Examination for General Certificate of Education Ordinary Level

Science

5124/1

Paper 1: Multiple Choice

Monday

11 JULY 2016

Additional materials:

Multiple Choice answer sheet

Soft clean eraser

Soft pencil (type B or HB is recommended)

Scientific calculator non-programmable or mathematical tables

Time: 1 hour

Instructions to Candidates

Do not open this booklet until you are told to do so.

Look at the left hand side of your answer sheet. Ensure that your name, the school/centre name and subject paper are **printed**. Also ensure that the subject code, paper number, centre code, your examination number and the year are **printed** and **shaded**. Do not change the already printed information.

There are **forty questions** in this paper. Answer **all** questions. For each question, there are **four** possible answers, **A, B, C** and **D**. Choose the one you consider correct and record your choice in soft pencil on the separate answer sheet.

Read very carefully the instructions on the answer sheet.

Information for Candidates

Each correct answer will score one mark. A mark will **not** be deducted for a wrong answer. Any rough working should be done in this question paper.

The **Periodic Table** is printed on page 12.

Cell phones are not allowed in the Examination Room.

1 What is the correct scientific notation of a quantity 157nm?

- A $1.57 \times 10^9\text{m}$
- B $1.57 \times 10^7\text{m}$
- C $1.57 \times 10^{-9}\text{m}$
- D $1.57 \times 10^{-7}\text{m}$

2 The diagram below shows how a Post Bus was moving.

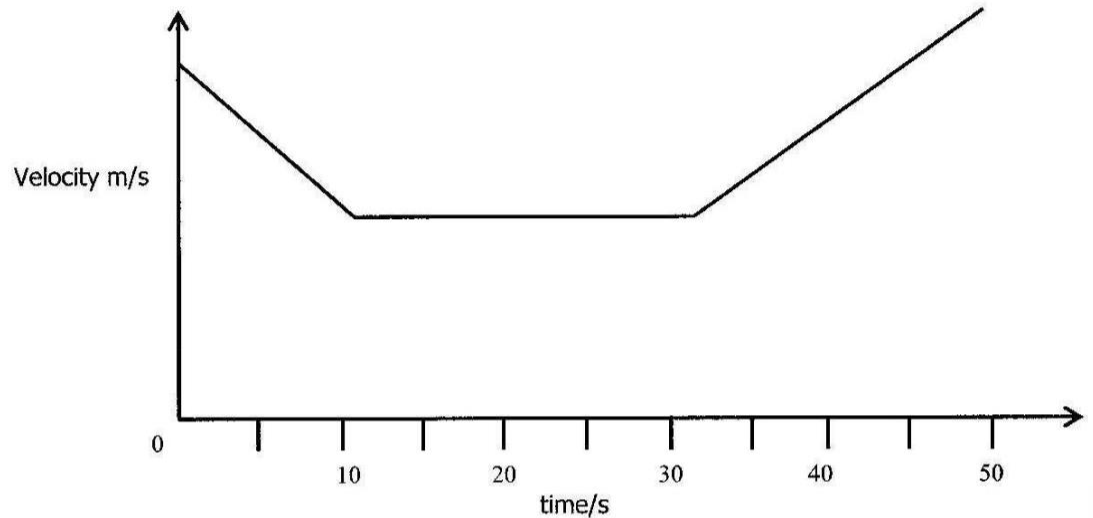

What was happening to the bus at time intervals of **5s – 10s**, **10s – 30s** and **30s – 50s**?

	5s - 10s	10s - 30s	30s - 50s
A	Reducing in speed	Moving at constant speed	Increased speed
B	Increased speed	Stopped	Started moving
C	Going down a slope	Moving at constant speed	Climbing a hill
D	Increased speed	Stopped	Reduced speed

3 Which one of the following is the correct weight of a 50kg bag of maize on both the moon and the earth?

	Moon	Earth
A	0.85N	50N
B	8.5N	50N
C	85N	500N
D	850N	500N

- 4 A 125g wooden plank was placed in a beaker, and below was the reading before and after placing it in the beaker.

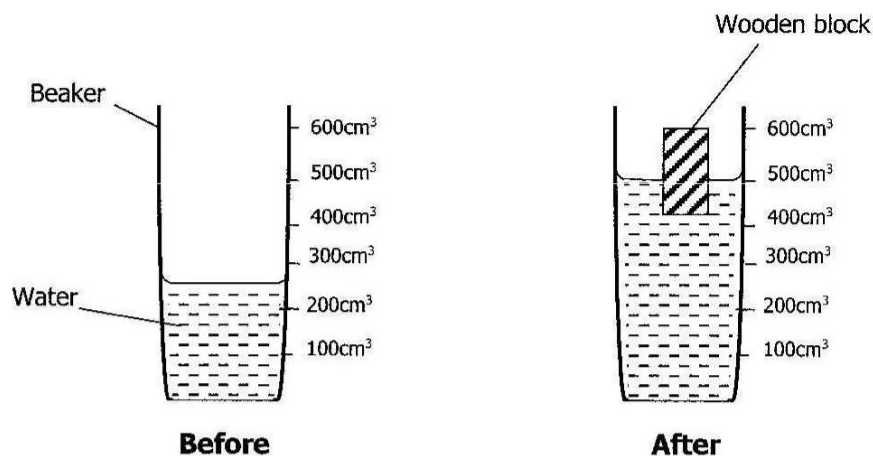

What is the density of the wooden block?

- A** 0.1 g/cm³
B 0.5 g/cm³
C 1.0 g/cm³
D 5.0 g/cm³
- 5 A 4kg brick is dropped from the top of a building whose height is 30m. The brick reaches the ground with a velocity of ...
- A** 1200 m/s.
B 43.6 m/s.
C 40 m/s.
D 34.6 m/s.
- 6 A machine with a velocity ratio of 6 requires 800J of work to raise a load of 60kg through a vertical distance of 1m.
 Find the mechanical advantage of the machine.
- A** 0.45
B 0.75
C 4.5
D 75.0
- 7 The common understanding of energy conservation is that it ...
- A** can be transformed from one form to another.
B remains the same in all forms.
C can be destroyed.
D can be created.

- 8 The higher an object is from the ground, the ...
- A more potential energy it has.
 - B higher its centre of mass is.
 - C lower its centre of mass is.
 - D more unstable it is.
- 9 In order to create a temperature scale, two fixed points are needed; the ice point and the steam point.
Which of the following is used to determine the ice point? The temperature ...
- A at which sea water freezes.
 - B at which snow melts.
 - C of ice in a freezer.
 - D of melting point of pure ice.
- 10 It was discovered that 120 crests passed through a slit in two hours.
What is the frequency of this wave?
- A 100Hz
 - B 60Hz
 - C 2Hz
 - D 1Hz
- 11 Which type of the electromagnetic radiation has the longest wavelength?
- A Infra-red rays
 - B Radio waves
 - C Ultraviolet rays
 - D X-rays
- 12 Which of the following correctly gives the properties of the sound waves?
- | | Nature | Speed in air |
|---|---------------|-----------------------|
| A | Longitudinal | 340m/s |
| B | Longitudinal | 3.0×10^8 m/s |
| C | Transverse | 340m/s |
| D | Transverse | 3.0×10^8 m/s |
- 13 The process of removing magnetic properties from a magnet is known as ...
- A attraction and repulsion.
 - B demagnetisation.
 - C induction.
 - D magnetisation.

- 14** An electric bulb is rated 1,200 watts.
If the current flowing in the filament of the bulb is 5A, what is the resistance of this bulb?
- A** 240 ohms
B 96 ohms
C 48 ohms
D 28 ohms
- 15** The diagram below shows a circuit with an ammeter and two resistors connected.

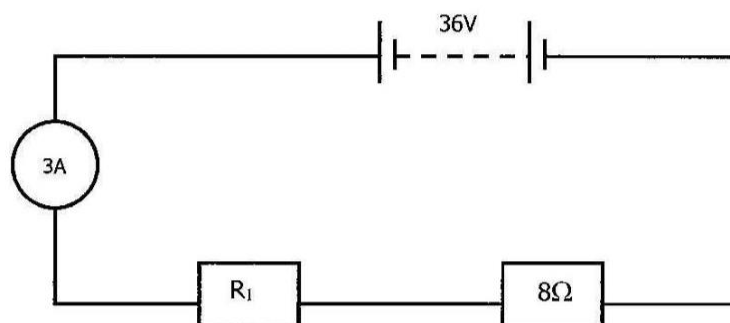

- If the ammeter reading is 3A, what is the value of resistor R_1 ?
- A** 4Ω
B 6Ω
C 12Ω
D 18Ω
- 16** Which part of the Cathode Ray Oscilloscope (CRO) emits electrons by thermionic emission?
- A** Cylindrical anode
B X-plates
C Cathode plate
D Y-plates

- 17 The diagram below shows a transformer.

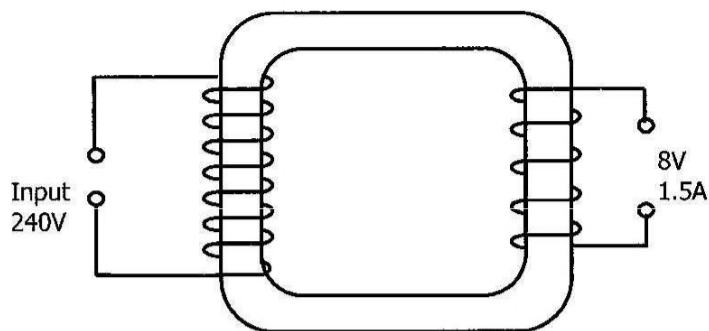

Assuming the transformer is 100% efficient, what is the size of the electric current in the primary coil?

- A 5.0A
 - B 2.5A
 - C 0.2A
 - D 0.05A
- 18 A radioactive element Yttrium ${}_{39}^{89}\text{Y}$ decays to isotopes rubidium ${}_{37}^{85}\text{Rb}$ according to the decay equation.

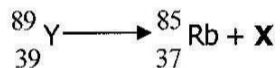

What could be X?

- A Gamma radiation
 - B Beta particle
 - C Alpha particle
 - D Both alpha and Gamma particles
- 19 A radioactive substance has a mass of 600g and a half life of 12 years. How much of this substance decays after 36 years.
- A 75g
 - B 125g
 - C 475g
 - D 525g

- 20 Which of the following statements correctly shows the name of the nuclear radiation and its use?

	Name of radiation	Use of nuclear radiation
A	Alpha particle	Treatment of cancer
B	Gamma rays	Monitoring paper thickness
C	Gamma rays	Treatment of cancer
D	Beta particle	Sterilizing instruments

- 21 The proof that matter is made up of tiny particles which cannot be seen is studied in ...

- A Wave motion
 B Brownian motion.
 C Random motion.
 D Particle motion.

- 22 The diagram below shows an arrangement of apparatus used to separate a mixture of methanol boiling point 15°C and water boiling point 100°C .

Which part of the apparatus is wrongly arranged and what is likely to be liquid J when corrected?

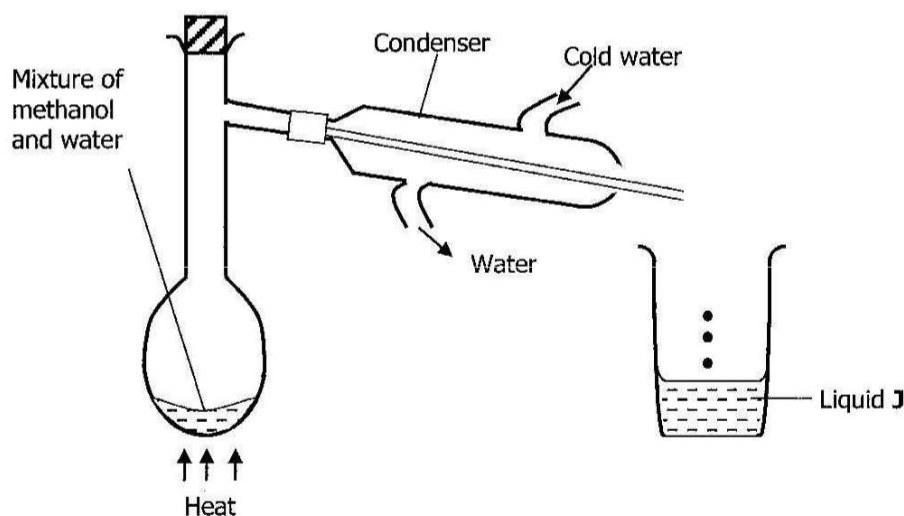

Correction

- A Heat the condenser
 B Cold water should enter from bottom and leave through the top.
 C No heating of the mixture is required
 D Cold water should enter from the bottom and leave through the top.

Liquid J

- Water
 Methanol
 Methanol
 Water

- 23 The element with a symbol **X** has an atomic number 12 and another element **Y** has atomic number 7.

What is the formula of the compound formed between elements **X** and **Y**?

- A** XY_3
B X_2Y_3
C X_3Y_2
D X_3Y
- 24 What is the mass of water produced when 58g of butane (C_4H_{10}) burns completely in air according to the equation below.

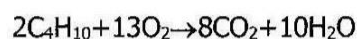

- A** 90g
B 80g
C 68g
D 60g
- 25 Potassium hydroxide reacts with phosphoric acid as follows:

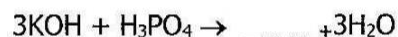

- A** K_2PO_4
B K_3PO_4
C K_4PO_3
D K_4PO_4
- 26 The chemical equation below illustrates the complete combustion of ethanol in air.

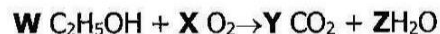

Find the values of **W**, **X**, **Y** and **Z** in the above chemical equation.

	W	X	Y	Z
A	2	6	4	6
B	1	3	2	3
C	2	4	4	6
D	1	1	2	3

- 27** A few drops of universal indicator were added to a soil sample solution. The indicator turned yellow.

What is the nature of the soil sample?

- A** Acidic
B Basic
C Neutral
D Salty
- 28** How does the atomic structure of an element relate to the Periodic Table?
- A** The valency shell determine the group for the element.
B The valency electrons determine the period for the element.
C Number of electron shells determines the group for the element.
D Number of electron shells determines the period for the element.
- 29** The preparation of lead (II) sulphate salt is best done by using which chemical equation?
- A** $\text{Pb}_{(s)} + \text{H}_2\text{SO}_{4(aq)} \rightarrow \text{PbSO}_{4(s)} + \text{H}_2(g)$
B $\text{PbO}_{(s)} + \text{H}_2\text{SO}_{4(aq)} \rightarrow \text{PbSO}_{4(s)} + \text{H}_2\text{O}(l)$
C $\text{Pb}(\text{NO}_3)_{2(aq)} + \text{H}_2\text{SO}_{4(aq)} \rightarrow \text{PbSO}_{4(s)} + 2\text{HNO}_{3(aq)}$
D $\text{PbCl}_{2(s)} + \text{Na}_2\text{SO}_{4(aq)} \rightarrow \text{PbSO}_{4(s)} + 2\text{NaCl}_{(aq)}$
- 30** The substance which dissolves in water to form a solution that changes universal indicator to blue is called ...
- A** an acid anhydride.
B a basic salt.
C an amphoteric oxide.
D an alkali.
- 31** Which of the following statements is the correct characteristic of the elements found between group II and group III of the Periodic Table?
- A** Their oxides dissolve in water leaving an alkaline solution.
B Their compounds usually form coloured solutions.
C They all displace hydrogen from dilute sulphuric acid.
D Their oxides are thermally stable.

32 Element **T** floats on water and reacts violently with cold water. Identify element **T**.

- A** Aluminum
- B** Barium
- C** Carbon
- D** Potassium

33 Dilute hydrochloric acid solution was added to substance **X** and effervescence was observed. The gas was bubbled through solution **Y** and the solution formed a white suspension. What is the identity of substance **X** and solution **Y**?

	Substance X	Solution Y
A	Carbonate	Calcium hydroxide
B	Metal	Universal indicator
C	Carbonate	Calcium carbonate
D	Nitrate	Litmus solution

34 Choose a set which corresponds to a metal and the main ore from which it is obtained.

	Metal	Mineral ore
A	Zinc	Bauxite
B	Copper	Bauxite
C	Iron	Magnetite
D	Aluminium	Magnetite

35 The correct description of non-metals is that they ...

- A** react with acids to form acid salts.
- B** oxidize by loss of electrons.
- C** form basic oxides when they react with oxygen.
- D** form acidic oxides when they react with oxygen.

36 The correct description for the distinguishing test between alkane and alkenes is that ...

- A** alkenes quickly decolourise aqueous bromine, while the alkane do not.
- B** alkanes quickly decolourise aqueous bromine, while the alkenes do not.
- C** alkanes react with steam while alkenes do not.
- D** alkanes undergo polymerisation, while alkenes do not.

37 Halogens belong to Group VII of the Periodic Table, and have a valency of one because they ...

- A** have seven electrons each.
- B** ionise by gain of one electron.
- C** ionise by loss of one electron.
- D** all exist as diatomic molecules in nature.

38 Polymers are very cheap plastics and are widely used by mankind.

What is the best way of disposing them off?

- A** Burning them completely in air
- B** Creating dumping sites for them
- C** Leaving them to rot on land
- D** Bury them

39 The major pollutant on the Copperbelt comes from the copper smelters.

Which of the following information gives the correct identity of the pollutant and its adverse effect of the environment?

	Identity	Adverse effect
A	Sulphur	Forms acid rain
B	Sulphur dioxide	Causes bronchitis
C	Nitrogen dioxide	Causes bronchitis
D	Carbon dioxide	Depletes the ozone layer

40 The table below gives information on the suitable monomer, polymer formed and its use.

	Monomer	Polymer	Use
A	$-O-\square-$	$[-O-\square-]_n$	Making ropes
B	$\begin{array}{c} F F \\ \\ C=C \\ \\ F F \end{array}$	$\left(\begin{array}{c} F F \\ \\ -C=C- \\ \\ F F \end{array} \right)_n$	Making artificial ball and socket joints
C	$\begin{array}{c} H H \\ \\ C=C \\ \\ H H \end{array}$	$\left(\begin{array}{c} H H \\ \\ -C=C- \\ \\ H H \end{array} \right)_n$	Making curtains
D	$\begin{array}{c} H H \\ \\ C=C \\ \\ H C H \end{array}$	$\left(\begin{array}{c} H H \\ \\ -C=C- \\ \\ H C H \end{array} \right)_n$	Making fishing lines

Which set of information above is correct?

DATA SHEET

The Periodic Table of the Elements

Group		I	II	III	IV	V	VI	VII	0																														
		<table border="1" style="width: 100%; border-collapse: collapse; text-align: center;"> <tr> <td style="width: 10%;">1</td> <td style="width: 10%;">H</td> <td colspan="6"></td> <td style="width: 10%;">4</td> <td style="width: 10%;">He</td> </tr> <tr> <td></td> <td>Hydrogen</td> <td colspan="6"></td> <td></td> <td>Helium</td> </tr> <tr> <td></td> <td>1</td> <td colspan="6"></td> <td>2</td> <td></td> </tr> </table>								1	H							4	He		Hydrogen								Helium		1							2	
1	H							4	He																														
	Hydrogen								Helium																														
	1							2																															
7	9	3	4	5	6	7	8	9	10																														
Li	Be	B	C	N	O	F	Ne																																
Lithium	Beryllium	Boron	Carbon	Nitrogen	Oxygen	Fluorine	Neon																																
11	12	13	14	15	16	17	18																																
Na	Mg	Al	Si	P	S	Cl	Ar																																
Sodium	Magnesium	Aluminium	Silicon	Phosphorus	Sulphur	Chlorine	Argon																																
19	20	21	22	23	24	25	26	27	28																														
K	Ca	Sc	Ti	V	Cr	Mn	Fe	Cu	Zn																														
Potassium	Calcium	Scandium	Titanium	Vanadium	Chromium	Manganese	Iron	Copper	Zinc																														
37	38	39	40	41	42	43	44	45	46																														
Rb	Sr	Y	Zr	Nb	Mo	Tc	Ru	Rh	Pd																														
Rubidium	Strontium	Yttrium	Zirconium	Niobium	Molybdenum	Technetium	Ruthenium	Rhodium	Palladium																														
55	56	57	58	59	60	61	62	63	64																														
Cs	Ba	La	Hf	Ta	W	Re	Os	Ir	Pt																														
Cesium	Barium	Lanthanum	Hafnium	Tantalum	Tungsten	Rhenium	Osmium	Iridium	Platinum																														
87	88	89	90	91	92	93	94	95	96																														
Fr	Ra	Ac	Th	Pa	U	Np	Pu	Am	Cm																														
Francium	Radium	Actinium	Thorium	Protactinium	Uranium	Neptunium	Plutonium	Americium	Curium																														
			90	91	92	93	94	95	96																														
			Th	Pa	U	Np	Pu	Am	Cm																														
			Thorium	Protactinium	Uranium	Neptunium	Plutonium	Americium	Curium																														
			232	238	238	238	238	238	238																														
			90	91	92	93	94	95	96																														
			Th	Pa	U	Np	Pu	Am	Cm																														
			Thorium	Protactinium	Uranium	Neptunium	Plutonium	Americium	Curium																														
			90	91	92	93	94	95	96																														
			Th	Pa	U	Np	Pu	Am	Cm																														
			Thorium	Protactinium	Uranium	Neptunium	Plutonium	Americium	Curium																														
			90	91	92	93	94	95	96																														
			Th	Pa	U	Np	Pu	Am	Cm																														
			Thorium	Protactinium	Uranium	Neptunium	Plutonium	Americium	Curium																														
			90	91	92	93	94	95	96																														
			Th	Pa	U	Np	Pu	Am	Cm																														
			Thorium	Protactinium	Uranium	Neptunium	Plutonium	Americium	Curium																														
			90	91	92	93	94	95	96																														
			Th	Pa	U	Np	Pu	Am	Cm																														
			Thorium	Protactinium	Uranium	Neptunium	Plutonium	Americium	Curium																														
			90	91	92	93	94	95	96																														
			Th	Pa	U	Np	Pu	Am	Cm																														
			Thorium	Protactinium	Uranium	Neptunium	Plutonium	Americium	Curium																														
			90	91	92	93	94	95	96																														
			Th	Pa	U	Np	Pu	Am	Cm																														
			Thorium	Protactinium	Uranium	Neptunium	Plutonium	Americium	Curium																														
			90	91	92	93	94	95	96																														
			Th	Pa	U	Np	Pu	Am	Cm																														
			Thorium	Protactinium	Uranium	Neptunium	Plutonium	Americium	Curium																														
			90	91	92	93	94	95	96																														
			Th	Pa	U	Np	Pu	Am	Cm																														
			Thorium	Protactinium	Uranium	Neptunium	Plutonium	Americium	Curium																														
			90	91	92	93	94	95	96																														
			Th	Pa	U	Np	Pu	Am	Cm																														
			Thorium	Protactinium	Uranium	Neptunium	Plutonium	Americium	Curium																														
			90	91	92	93	94	95	96																														
			Th	Pa	U	Np	Pu	Am	Cm																														
			Thorium	Protactinium	Uranium	Neptunium	Plutonium	Americium	Curium																														
			90	91	92	93	94	95	96																														
			Th	Pa	U	Np	Pu	Am	Cm																														
			Thorium	Protactinium	Uranium	Neptunium	Plutonium	Americium	Curium																														
			90	91	92	93	94	95	96																														
			Th	Pa	U	Np	Pu	Am	Cm																														
			Thorium	Protactinium	Uranium	Neptunium	Plutonium	Americium	Curium																														
			90	91	92	93	94	95	96																														
			Th	Pa	U	Np	Pu	Am	Cm																														
			Thorium	Protactinium	Uranium	Neptunium	Plutonium	Americium	Curium																														
			90	91	92	93	94	95	96																														
			Th	Pa	U	Np	Pu	Am	Cm																														
			Thorium	Protactinium	Uranium	Neptunium	Plutonium	Americium	Curium																														
			90	91	92	93	94	95	96																														
			Th	Pa	U	Np	Pu	Am	Cm																														
			Thorium	Protactinium	Uranium	Neptunium	Plutonium	Americium	Curium																														
			90	91	92	93	94	95	96																														
			Th	Pa	U	Np	Pu	Am	Cm																														
			Thorium	Protactinium	Uranium	Neptunium	Plutonium	Americium	Curium																														
			90	91	92	93	94	95	96																														
			Th	Pa	U	Np	Pu	Am	Cm																														
			Thorium	Protactinium	Uranium	Neptunium	Plutonium	Americium	Curium																														
			90	91	92	93	94	95	96																														
			Th	Pa	U	Np	Pu	Am	Cm																														
			Thorium	Protactinium	Uranium	Neptunium	Plutonium	Americium	Curium																														
			90	91	92	93	94	95	96																														
			Th	Pa	U	Np	Pu	Am	Cm																														
			Thorium	Protactinium	Uranium	Neptunium	Plutonium	Americium	Curium																														
			90	91	92	93	94	95	96																														
			Th	Pa	U	Np	Pu	Am	Cm																														
			Thorium	Protactinium	Uranium	Neptunium	Plutonium	Americium	Curium																														
			90	91	92	93	94	95	96																														
			Th	Pa	U	Np	Pu	Am	Cm																														
			Thorium	Protactinium	Uranium	Neptunium	Plutonium	Americium	Curium																														
			90	91	92	93	94	95	96																														
			Th	Pa	U	Np	Pu	Am	Cm																														
			Thorium	Protactinium	Uranium	Neptunium	Plutonium	Americium	Curium																														
			90	91	92	93	94	95	96																														
			Th	Pa	U	Np	Pu	Am	Cm																														
			Thorium	Protactinium	Uranium	Neptunium	Plutonium	Americium	Curium																														
			90	91	92	93	94	95	96																														
			Th	Pa	U	Np	Pu	Am	Cm																														
			Thorium	Protactinium	Uranium	Neptunium	Plutonium	Americium	Curium																														
			90	91	92	93	94	95	96																														
			Th	Pa	U	Np	Pu	Am	Cm																														
			Thorium	Protactinium	Uranium	Neptunium	Plutonium	Americium	Curium																														
			90	91	92	93	94	95	96																														
			Th	Pa	U	Np	Pu	Am	Cm																														
			Thorium	Protactinium	Uranium	Neptunium	Plutonium	Americium	Curium																														
			90	91	92	93	94	95	96																														
			Th	Pa	U	Np	Pu	Am	Cm																														
			Thorium	Protactinium	Uranium	Neptunium	Plutonium	Americium	Curium																														
			90	91	92	93	94	95	96																														
			Th	Pa	U	Np	Pu	Am	Cm																														
			Thorium	Protactinium	Uranium	Neptunium	Plutonium	Americium	Curium																														
			90	91	92	93	94	95	96																														
			Th	Pa	U	Np	Pu	Am	Cm																														
			Thorium	Protactinium	Uranium	Neptunium	Plutonium	Americium	Curium																														
			90	91	92	93	94	95	96																														
			Th	Pa	U	Np	Pu	Am	Cm																														
			Thorium	Protactinium	Uranium	Neptunium	Plutonium	Americium	Curium																														
			90	91	92	93	94	95	96																														
			Th	Pa	U	Np	Pu	Am	Cm																														
			Thorium	Protactinium	Uranium	Neptunium	Plutonium	Americium	Curium																														
			90	91	92	93	94	95	96																														
			Th	Pa	U	Np	Pu	Am	Cm																														
			Thorium	Protactinium	Uranium	Neptunium	Plutonium	Americium	Curium																														
			90	91	92	93	94	95	96																														
			Th	Pa	U	Np	Pu	Am	Cm																														
			Thorium	Protactinium	Uranium	Neptunium	Plutonium	Americium	Curium																														
			90	91	92	93	94	95	96																														
			Th	Pa	U	Np	Pu	Am	Cm																														
			Thorium	Protactinium	Uranium	Neptunium	Plutonium	Americium	Curium																														
			90	91	92	93	94	95	96																														
			Th	Pa	U	Np	Pu	Am	Cm																														
			Thorium	Protactinium	Uranium	Neptunium	Plutonium	Americium	Curium																														
			90	91	92	93	94	95	96																														
			Th	Pa	U	Np	Pu	Am	Cm																														
			Thorium	Protactinium	Uranium	Neptunium	Plutonium	Americium	Curium																														
			90	91	92	93	94	95	96																														
			Th	Pa	U	Np	Pu	Am	Cm																														
			Thorium	Protactinium	Uranium	Neptunium	Plutonium	Americium	Curium																														
			90	91	92	93	94	95	96																														
			Th	Pa	U	Np	Pu	Am	Cm																														
			Thorium	Protactinium	Uranium	Neptunium	Plutonium	Americium	Curium																														
			90	91	92	93	94	95	96																														
			Th	Pa	U	Np	Pu	Am	Cm																														
			Thorium	Protactinium	Uranium	Neptunium	Plutonium	Americium	Curium																														
			90	91	92	93	94	95	96																														
			Th	Pa	U	Np	Pu	Am	Cm																														
			Thorium	Protactinium	Uranium	Neptunium	Plutonium	Americium	Curium																														
			90	91	92	93	94	95	96																														
			Th	Pa	U	Np	Pu	Am	Cm																														
			Thorium	Protactinium	Uranium	Neptunium	Plutonium	Americium	Curium																														
			90	91	92	93	94	95	96																														
			Th	Pa	U	Np	Pu	Am	Cm																														
			Thorium	Protactinium	Uranium	Neptunium	Plutonium	Americium	Curium																														
			90	91	92	93	94	95	96																														
			Th	Pa	U	Np	Pu	Am	Cm																														
			Thorium	Protactinium	Uranium																																		