

**MEC 3102 – PRODUCTION ENGINEERING I AND
ELECTRICITY & ELECTRONICS II**
Department of Mechanical Engineering
The University of Zambia

Name: Mr. Munkombwe Boyd,

Old School of Engineering Blg.,

Cell: 0968315273/0950435239

Email: boyd.munkombwe@unza.zm

2nd Series Lecture 5[1]

2. A.C. Generators

Basic Principle

A.C. generators or alternators (as they are commonly called) operate on the same fundamental principles of electromagnetic induction as d.c. generators. They also consist of an armature winding and a field winding.

Difference between the two:

- In a d.c. generator, the armature rotates and the field system is stationary.
- In a.c. generators, the field system rotates and the armature is stationary.

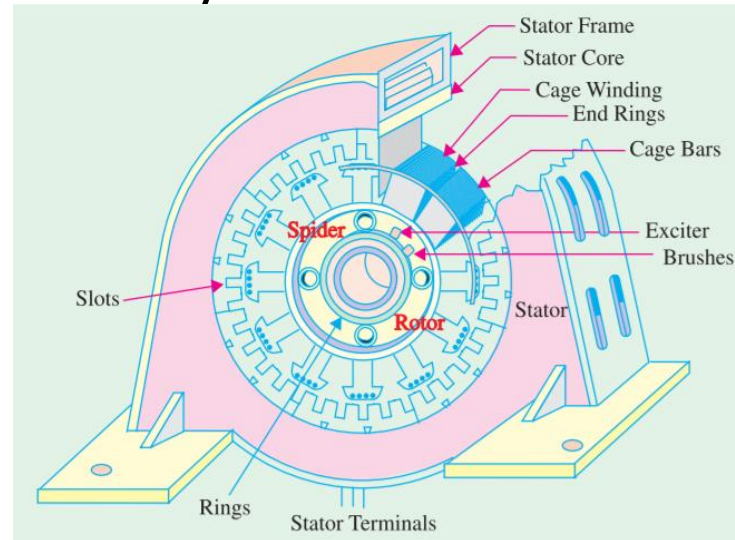

Fig. 2.1. A.C. Generator

- The rotor consists of two electro-magnetic poles (N and S) that are excited (or magnetised) from d.c. current supplied by a d.c. source at 125 to 600 volts.
 - When the rotor rotates, the stator conductors (being stationary) are cut by the magnetic flux, hence the induced e.m.f produced in them.
 - Because the magnetic poles are alternately N and S, they induce an e.m.f. and hence current in the armature conductors, which first flows in one direction and then in the other.
- Hence, an alternating e.m.f. is produced in the stator conductors:
- i. Whose frequency depends on the number of N and S poles moving past a conductor in one second and
 - ii. Whose direction is given by Fleming's Right-hand rule.

Speed and Frequency

- In an alternator, there is a definite relationship between the rotational speed (N) of the rotor, the frequency (f) of the generated e.m.f. and the number of poles P.

$$\bullet f = \frac{PN}{120} \text{ Hz}$$

- N is known as the **synchronous speed**, because it is the speed at which an alternator must run in order to generate an e.m.f. of the required frequency.

Equation of induced E.M.F.

- Let
- z = No. of conductors or coil sides in series/phase
= $2T$ – where T is the No. of coils or turns per phase
 - P = No. of poles
 - f = frequency of induced e. m. f. in Hz
 - ϕ = flux/pole in webers
 - K_d = distribution factor
 - K_c or K_p = pitch or coil span factor
 - K_f = form factor = **1.11**
 - N = rotor speed in r. p. m.

In one revolution of the rotor, each stator conductor is cut by flux of ϕP Wb (in $60/N$ seconds).

In one revolution of the rotor (*i.e.* in $60/N$ second) each stator conductor is cut by a flux of ΦP webers.

$$\therefore d\Phi = \Phi P \text{ and } dt = 60/N \text{ second}$$

$$\therefore \text{Average e.m.f. induced per conductor} = \frac{d\Phi}{dt} = \frac{\Phi P}{60/N} = \frac{\Phi NP}{60}$$

Now, we know that $f = PN/120$ or $N = 120 f/P$

Substituting this value of N above, we get

$$\text{Average e.m.f. per conductor} = \frac{\Phi P}{60} \times \frac{120 f}{P} = 2f \Phi \text{ volt}$$

If there are Z conductors in series/phase, then Average e.m.f./phase = $2f \Phi Z$ volt = $4f \Phi T$ volt

$$\text{R.M.S. value of e.m.f./phase} = 1.11 \times 4f \Phi T = 4.44f \Phi T \text{ volt}^*.$$

This would have been the actual value of the induced voltage if all the coils in a phase were **(i)** full-pitched and **(ii)** concentrated or bunched in one slot (instead of being distributed in several slots under poles). But this not being so, the actually available voltage is reduced in the ratio of these two factors.

$$\therefore \text{Actually available voltage/phase} = 4.44 k_c k_d f \Phi T = 4 k_f k_c k_d f \Phi T \text{ volt.}$$

If the alternator is star-connected (as is usually the case) then the line voltage is $\sqrt{3}$ times the phase voltage (as found from the above formula).

- **Examples:**

1. A 3-phase, 16-pole alternator has a star-connected winding with 144 slots and 10 conductors per slot. The flux per pole is 0.03 Wb, sinusoidally distributed and the speed is 375 r.p.m. Find the frequency rpm and the phase and line e.m.f. assuming $K_c = 1$, $K_d = 0.96$.

- **Solution:**

$$f = \frac{PN}{120} \text{ Hz} = \frac{16 \times 375}{120} = \mathbf{50 \text{ Hz}}$$

$$Z = 144 \times \frac{10}{3} = 480; T = \frac{480}{2} = 240/\text{phase}$$

Thus, $E_{ph} = 4.44 \times 1 \times 0.96 \times 50 \times 0.03 \times 240 = \mathbf{1534.46 \text{ V}}$

$$E_L = \sqrt{3}E_{ph} = \sqrt{3} \times 1534 = \mathbf{2657.78 \text{ V}}$$

2. Find the no-load phase and line voltages of a star-connected 3-phase, 54 stator-slot, 6-pole alternator which runs at 1200 r.p.m., having a flux per pole of 0.1 Wb sinusoidally distributed. Each coil has 8 turns and the coil is corded by 1. Assume $K_c = 0.98$, $K_d = 0.96$.

• **Solution:**

$$f = \frac{PN}{120} \text{ Hz} = \frac{6 \times 1200}{120} = 60 \text{ Hz}$$

$$Z = 54 \times \frac{8}{3} = 144; T = \frac{144}{2} = 72 / \text{phase}$$

$$E_{ph} = 4.44 \times 0.98 \times 0.96 \times 60 \times 0.1 \times 72 = \mathbf{1805.53 \text{ V}}$$

$$E_L = \sqrt{3} E_{ph} = \sqrt{3} \times 1805.53 = \mathbf{3125.54 \text{ V}}$$

3. DC MOTORS

5.4 DC Motor

- An electrical machine that converts d.c. power into mechanical power is called a **DC motor**.
- The operation of a motor is based on **Maxwell's Law**: When a current-carrying conductor of length l is placed at right angles to a uniform magnetic field (of flux density B), experiences a mechanical force (F) whose magnitude is given by;

[Newtons]

$$F = Bli$$

Working principle:

- Consider a part of a multipolar d.c. motor as shown in fig. 5.1. when the armature of the motor are connected to an external source of a d.c. supply:
 - i. The field magnets are excited developing alternate N and S poles.
 - ii. The armature conductors carry currents, for which all conductors under the N-pole carry currents in one direction while all the conductors under S-pole carry currents in the opposite direction.

- Assuming all conductors under N-pole carry currents into the screen of the laptop, and those of the S-pole carry currents out of the screen of the laptop as in fig. 3.1.
- The fact that all armature conductors are carrying currents and are placed in a magnetic field, **mechanical force** acts on it.
- Applying **Fleming's left-hand rule**, it is obvious that the **force** on each conductor tends to rotate the armature in anticlockwise direction.
- When all these forces add together, they produce a **driving torque** which sets the armature in **rotation**.

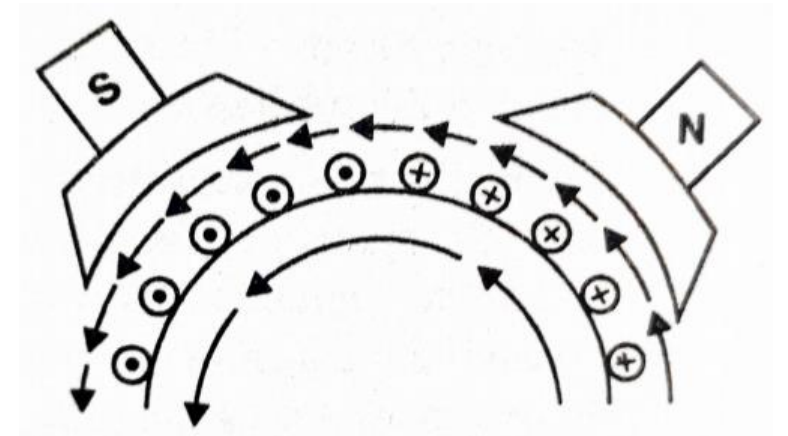

Fig. 3.1

Back or Counter E.M.F.

➤ As the motor rotates under the influence of the driving torque, the armature conductors move through the magnetic field and hence induces an e.m.f. in them as in a generator. The induced e.m.f acts in the **opposite direction** to the applied voltage. This e.m.f. is known as **back or counter e.m.f (E_b)** and always **less** than the **applied voltage**.

Back emf equation,

$$E_b = \frac{PZ\Phi N}{60A} \text{ Volts} \quad (3.1)$$

Torque equation,

$$T = \frac{PZ\Phi I_a}{2\pi A} \text{ N-m} \quad (3.2)$$

❖ **Importance of back e.m.f in a d.c. motor**; it regulates the flow of armature current i.e., is **automatically changes** the armature current to meet the **load requirements**

3.1 Comparison of Generator and Motor Action

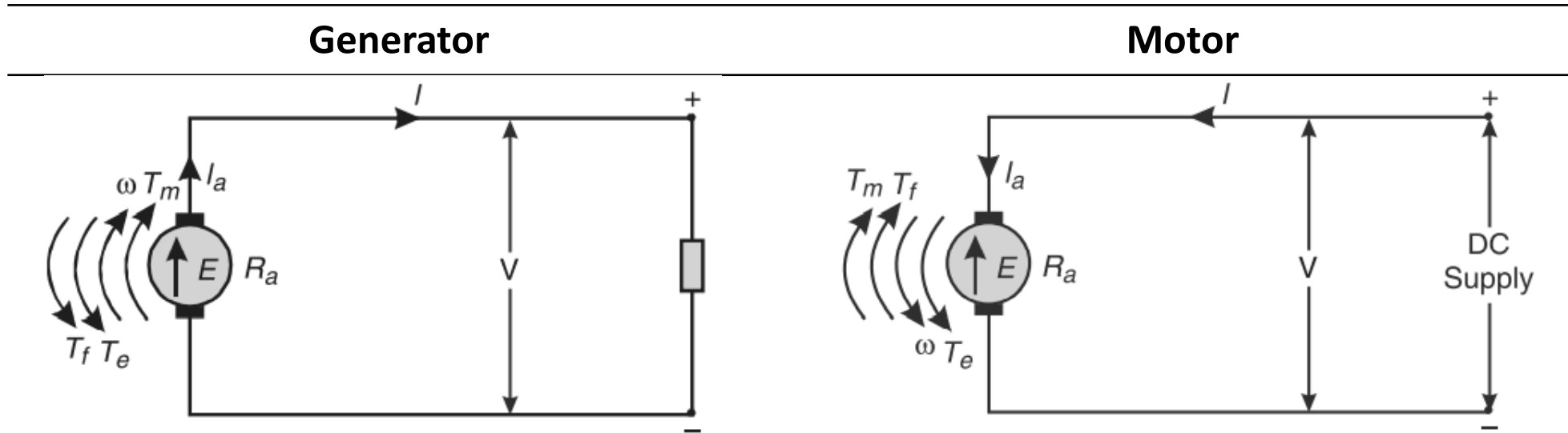

1. The rotation is due to mechanical torque, therefore, T_m and ω are in the same direction.
2. emf (e) and current flows in same direction
3. $E > V$
4. Mechanical energy is converted into electrical energy.

1. The rotation is due to electromagnetic torque, therefore, T_e and ω are in the same direction.
2. emf (e) and current flows in opposite direction
3. $E < V$
4. Electrical energy is converted into mechanical energy.

3.2 Types of DC Motors

1. Separately excited DC motors:

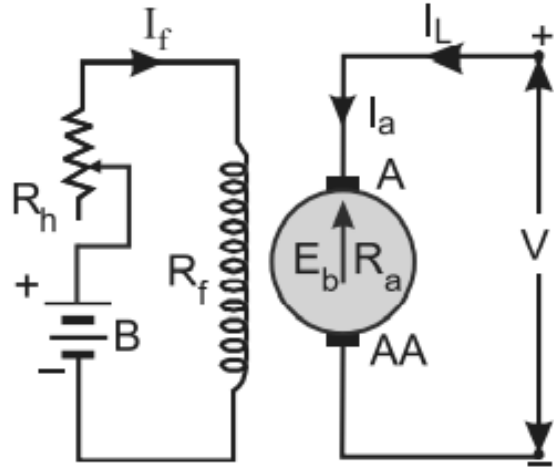

Fig. 3.2

$$E_b = V - I_a R_a \quad (3.3)$$

2. Self excited DC motors: These motors are further classified as

i. Shunt motors:

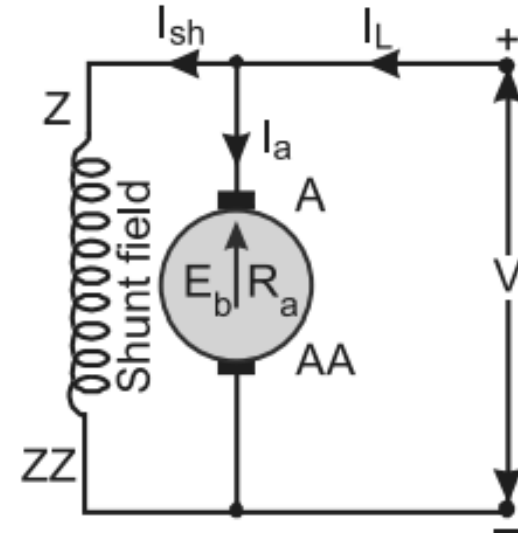

Fig. 3.3

$$I_{sh} = V / R_{sh} \quad (3.4)$$

$$I_a = I_L - I_{sh} \quad (3.5)$$

$$E_b = V - I_a R_a \quad (3.6)$$

ii. Series motor:

$$I_{se} = I_a = I_L \quad (3.7)$$

$$E_b = V - I_a(R_a + R_{se}) \quad (3.8)$$

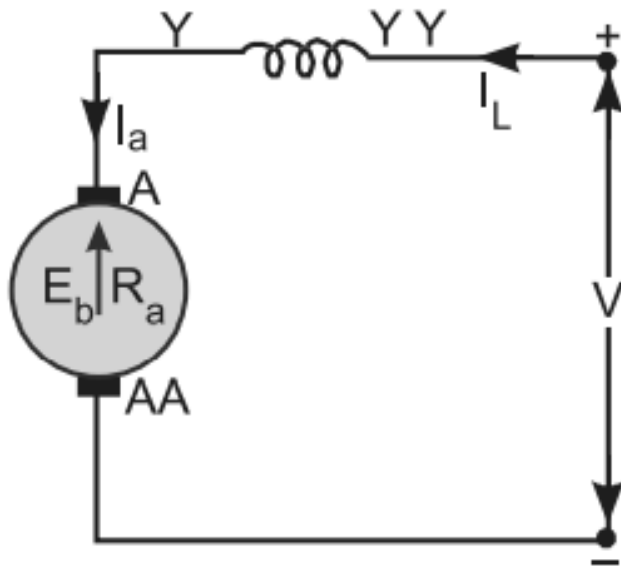

Fig. 3.4

iii. Compound motor:

$$I_{sh} = \frac{V}{R_{sh}}$$

$$I_a = I_L - I_{sh} \quad (3.9)$$

$$E_b = V - I_a(R_a + R_{se}) \quad (3.10)$$

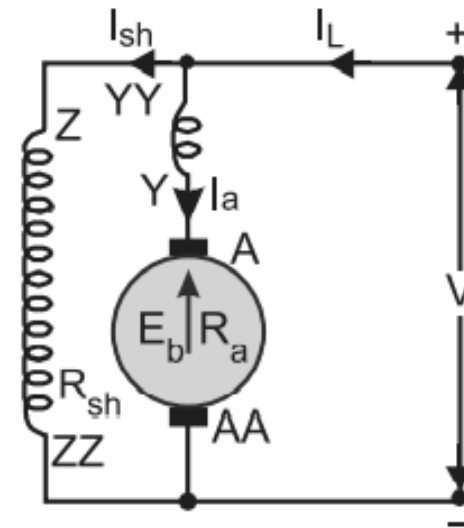

Fig. 3.5

The compound motor can be further subdivided as;

- a) **Cumulative compound motors:** In these motors, the flux produced by both the windings is in the same direction.
- b) **Differential compound motors:** In these motors, the flux produced by the series field winding is opposite to the flux produced by the shunt field winding.

Example 1:

The armature resistance of a DC shunt motor is 0.5 ohm, it draws 20 A from 220 V mains and is running at a speed of 80 radian per second. Determine: (i) Induced emf (ii) Electromagnetic torque (iii) Speed in rpm.

Solution:

Here, $V = 220 \text{ V}$; $I_a = 20 \text{ A}$; $R_a = 0.5 \text{ } \Omega$; $\omega = 80 \text{ rad/s}$

(i) Using equation (5.4)

$$E_b = V - I_a R_a$$

$$= 220 - (20 \times 0.5) = \mathbf{210 \text{ V}}$$

$$(ii) \quad E_b I_a = \omega T$$

$$\Rightarrow T = \frac{E_b I_a}{\omega} = \frac{210 \times 20}{80} = \mathbf{52.5 \text{ Nm}}$$

$$(iii) \quad N = \frac{60\omega}{2\pi} = \frac{60 \times 80}{2\pi} = \mathbf{764 \text{ rpm}}$$

Example 2:

The armature and shunt field resistance of a 4-pole, lap wound DC shunt motor is 0.05 ohm and 25 ohm respectively. If its armature contains 500 conductors, find the speed of the motor when it take 120 A from a DC mains of 100 V supply as shown in Fig. 3.6. Flux per pole is 2×10^{-2} Wb.

Solution:

Given, $P = A = 4$, $R_a = 0.05 \Omega$, $R_{sh} = 25 \Omega$,
 $Z = 500$, $I_L = 120 \text{ A}$, $V = 100 \text{ V}$,
 $\phi = 0.02 \text{ Wb}$

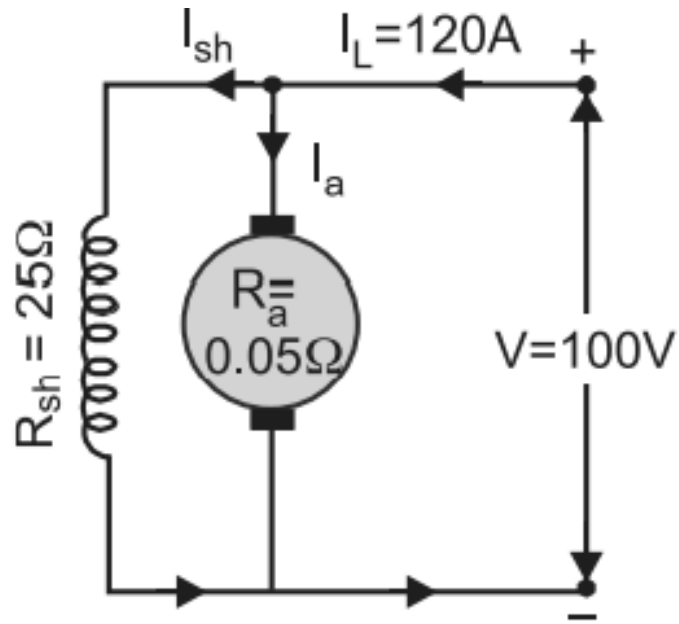

Fig. 3.6

$$I_{sh} = V/R_{sh} = \frac{100}{25} = 4 \text{ A}$$

$$I_a = I_L - I_{sh} = 120 - 4 = 116 \text{ A}$$

$$E_b = V - I_a R_a$$

$$= 100 - 116 \times 0.05 = \mathbf{94.2 \text{ V}}$$

Using (3.1)

$$E_b = \frac{PZ\Phi N}{60A}$$

$$94.2 = \frac{6 \times 0.02 \times 500 \times N}{60 \times 6}$$

$$\Rightarrow \mathbf{N = 565.2 \text{ rpm}}$$

3.3 Characteristics of DC Motors

The performance of a DC motor can be easily judged from its characteristic curves, known as *motor characteristics*. The following curves which show relation between the two quantities can be obtained:

1. **Speed and Armature current i.e., $N - I_a$ Characteristics:** It is the curve drawn between speed N and armature current I_a . It is also known as *speed characteristics*.
2. **Torque and Armature current i.e., $T - I_a$ Characteristics:** It is the curve drawn between torque developed in the armature T and armature current I_a . It is also known as *electrical characteristic*.
3. **Speed and Torque i.e., $N - T$ characteristics:** It is the curve drawn between speed N and torque developed in the armature T . It is also known as *mechanical characteristics*.

Remember the following important relations :

$$E_b \propto N\phi, \text{ or } N \propto \frac{E_b}{\phi}, \text{ and } T \propto \phi I_a$$

3.4 Characteristics of Shunt Motors

1. $N - I_a$ Characteristics

We know, $N \propto \frac{E_b}{\phi}$

since flux is constant;

$$N \propto E_b \text{ or } N \propto (V - I_a R_a)$$

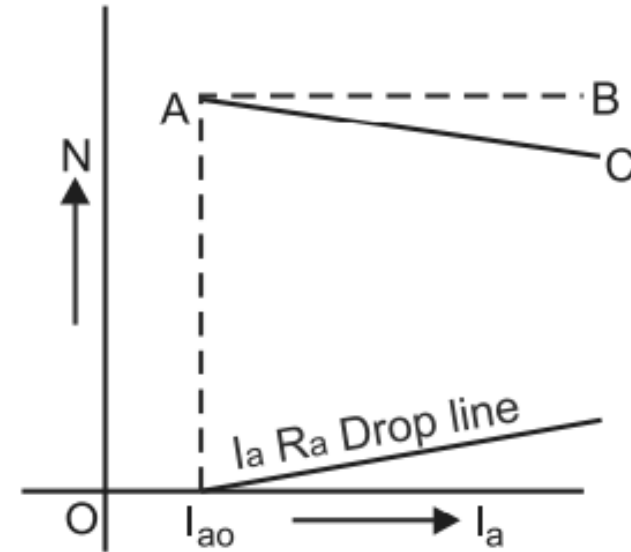

Fig. 3.7 $N - I_a$

- ❖ Since there is no appreciable change in the speed of a DC shunt motor from no-load to full load that is why it is considered to be a constant speed motor.

2. T- I_a Characteristics:

We know that, $T \propto \Phi I_a$

Since flux is constant, $T \propto I_a$

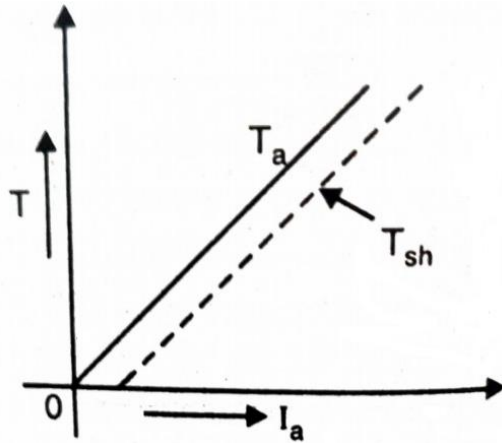

Fig. 3.8 T- I_a

Note:

- ✓ A large armature current is required at starting if the machine is on heavy load. Thus, shunt motor should never be started on load.
- ✓ The shaft torque is less than T_a as shown above.

3. N – T characteristics:

- ✓ When load torque increases, armature current I_a increases but speed decreases slightly. Thus with the increase in load or torque, the speed decreases slightly.

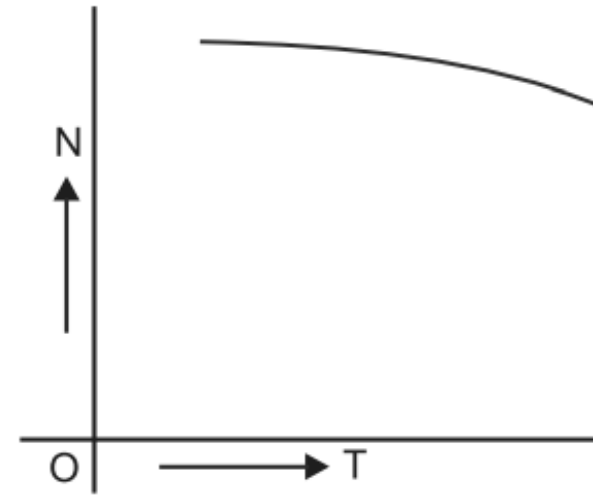

Fig. 3.9 N-T characteristics of shunt motor

3.5 Characteristics of Series Motors

1. $N - I_a$ Characteristics

We know that, $N \propto \frac{E_b}{\phi}$

Considering E_b to be constant,

$$N \propto \frac{1}{\phi} \propto \frac{1}{I_a}, \quad [\text{since } \phi \propto I_a]$$

Thus, before magnetic saturation, the $N - I_a$ curve follows the hyperbolic path.

After magnetic saturation, flux becomes constant, then

$$N \propto E_b \text{ or } N \propto V - I_a(R_a + R_{se})$$

Thus, after magnetic saturation, the $N - I_a$ curve follows a straight line path and speed decreases slightly.

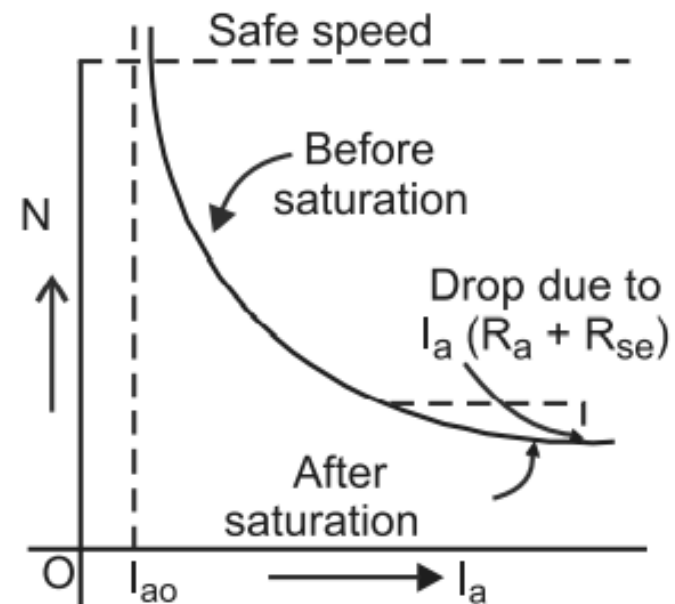

Fig. 3.10. $N - I_a$ characteristics of DC series motor

- Its speed changes when the armature current (or load) changes. As the load on this motor decreases, speed increases.
- Therefore, a series motor is never started on no-load.

2. $T-I_a$ Characteristics:

We know that, $T \propto \Phi I_a$

In series motors, before magnetic saturation, $\Phi \propto I_a$.

Hence, $T \propto I_a^2$

- ✓ However, after **magnetic saturation**, the flux Φ becomes constant, $T \propto I_a$, and the curve (AB) becomes a straight line.

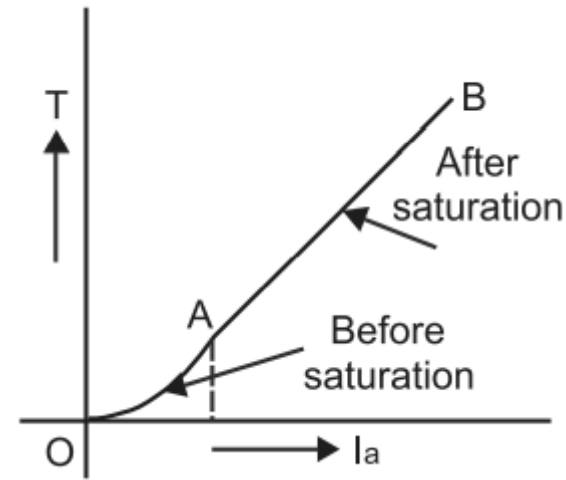

Fig. 3.11 $T-I_a$

- ✓ When load is applied to this motor at start, it takes large current and heavy torque is produced which is proportional to square of this current.
- ✓ Thus, this motor is capable to **pick up heavy loads** at the start and best suited for electric traction.

- **N – T characteristics:**

This characteristic is derived from the first two characteristics. At low value of load, I_a is small, torque is small but the speed is very high. As load increases, I_a increases, torque increases but the speed decreases rapidly.

Thus for increasing torque, speed decreases rapidly.

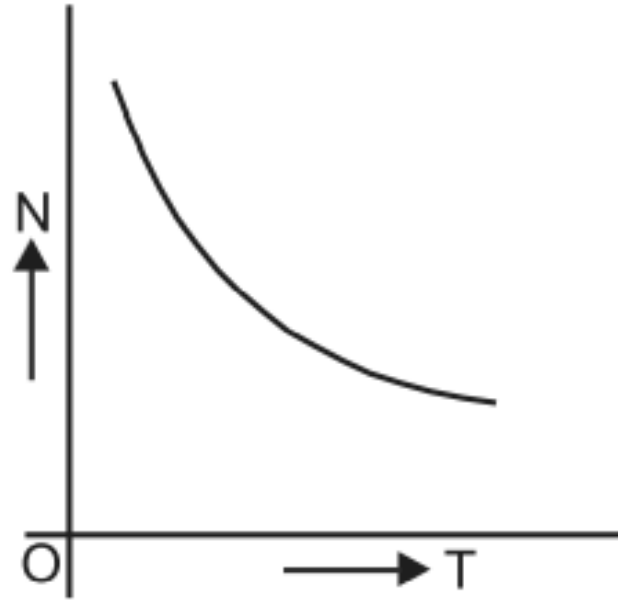

Fig. 5.12. N-T characteristics of DC series motor

3.6 Characteristics of Compound Motors

There are two types of compound wound DC motors namely; **cumulative compound motors** and **differential compound motors**. Cumulative compound motors are most common. The characteristics of these motors lies between the shunt and series motors.

1. Characteristics of cumulatively compound DC motor

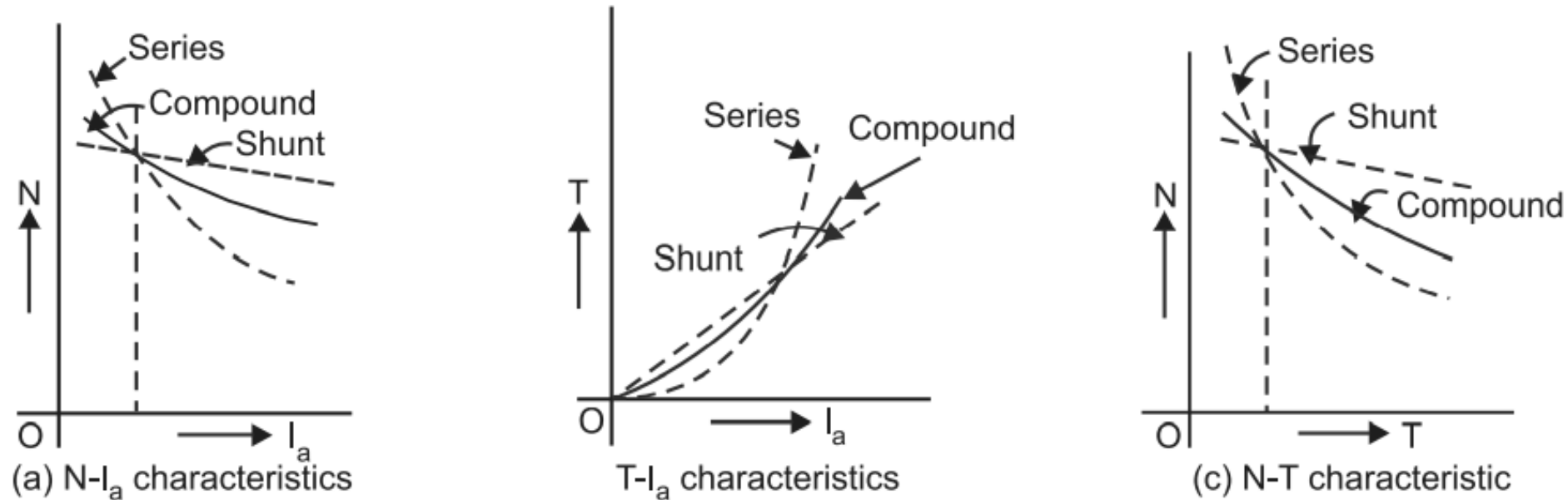

Fig. 3.13

- As shown in fig. 3.13
 - a) As the load increases, the total flux per pole increases. As a result, the speed of the motor falls as the load increases.
 - b) As the load increases, the series field increases but the shunt field strength remains constant. As a result, the total flux is increased and hence the armature torque.
 - c) For a given armature current, the torque of a commulative compound motor is more than that of a series motor but less than that of a shunt.

Note: Due to their poor torque characteristics, differential compound motors are rarely used.

3.7 Applications and Selection of DC Motors

1. **Separately excited motors:** Very accurate speeds can be obtained by these motors. Hence, these motors are best suited where speed variation is required from very low value to high value. They are used in steel rolling mills, paper mills, diesel – electric propulsion of ships, etc.
2. **Shunt motors:** it is almost constant speed motor. It is, therefore, used;
 - (i) Where the speed between no-load to full load has to be maintained almost constant.
 - (ii) Where it is required to drive the load at various speeds and any one of the speed is required to be maintained almost constant for a relatively long period.

They are suitable for lathes, drills, grinders, shapers, spinning and weaving machines, line shafts in the group drive, etc.

3. Series motors: it is a variable speed motor i.e., the speed is low at higher torques and vice-versa. At light loads or at no-load, the motor attains dangerously high speed. It is, therefore, employed:

- (i) Where high torque is required at the time of starting to accelerate heavy loads quickly.
- (ii) Where the load is subjected to heavy fluctuations and speed is required to be adjusted automatically.

As such the series motors are most suitable for *electric traction, cranes, elevators, vacuum cleaners, hair driers, sewing machines, fans and air compressors, etc.*

Note: These motors are always directly coupled with loads or coupled through gears. Belt loads are never applied to series motor, because the belt may slip over the pulley or it may break.

- 4. Compound motors:** The important characteristic of this motor is that the speed falls appreciably on heavy loads as in a series motor, but at light loads, the maximum speed is limited to safe value. It is, therefore, used;
- (i) Where high torque is required at the time of starting and where the load may be thrown off suddenly.
 - (ii) Where the load is subjected to heavy fluctuations. As such the cumulative compound motors are best suited for **punching** and **shearing machines**, **rolling mills**, **lifts and mine - hoists**, etc

3.8 Selection of DC Motors

While selecting a DC motor for a particular work, one is to consider the following points:

- 1. Selection of power rating:** A motor should be chosen of the size for its **maximum power** utilisation. During operation, it should be heated-up within the permissible temperature limits and it should never be overheated. But at the same time it should be capable to take-up the over-loads temporarily.
- 2. Characteristics of the motor:** One should know the following particulars of the work before selecting a motor: (i) **Torque requirement** during starting and running at different loads, (ii) Requirement of **accelerating** and **braking torque**, (iii) **Frequency of switching**, (iv) **Temperature** at the work place, (v) **Environmental conditions**, etc.

3.9 Starting of DC Motors

- To start a d.c motor, when it is switched–ON to the supply with full rated voltage, it draws **heavy current** during starting period (more than its rated value).
- This excessive current **overheats** the armature winding and may even damage the winding insulation. Therefore, during starting period a resistance called starter is connected in series with the armature circuit to limit the starting current.

➤ The speed of a d.c. motor is given by:

$$N \propto \frac{E_b}{\phi}$$

or

$$N = K \frac{(V - I_a R)}{\phi} \text{ r.p.m}$$

Where,

$$R = R_a \quad \text{For shunt motor}$$

$$= R_a + R_{se} \quad \text{For series motor}$$

- Thus, the main methods of controlling the speed of a dc motor are:
 - Flux control method:** by varying the flux per pole (ϕ).
 - Armature control method:** by varying the resistance in the armature circuit.
 - Voltage control method:** by varying the applied voltage V .