

**Mohr Stress diagram
or
Mohr Circle**

The Mohr Stress Diagram

The Mohr stress diagram gives us a very useful display of the stress equations.

The equations describe a circular locus of paired values (σ_N, σ_S) of the normal and shear stresses that operate on planes of any and all orientations within a given body subjected to known values of σ_1 and σ_3 .

Using the Mohr stress diagram, we can identify a plane of any orientation relative to σ_1 and then read directly from the diagram the values of normal stress (σ_N) and shear stress (σ_S) acting on the plane.

The construction of the Mohr stress circle proceeds as follows.

Principal normal stress values (σ_1 and σ_3) are plotted on the x-axis of the diagram (**Figure 3.23A**). A circle is drawn through these points such that $(\sigma_1 - \sigma_3)$ constitutes the circle's diameter. In the example of stress at P where $\sigma_1 = 40$ MPa and $\sigma_3 = 20$ MPa, all the paired values of σ_N and σ_S as listed in **Figure 3.17** exist as points on the perimeter of the circle.

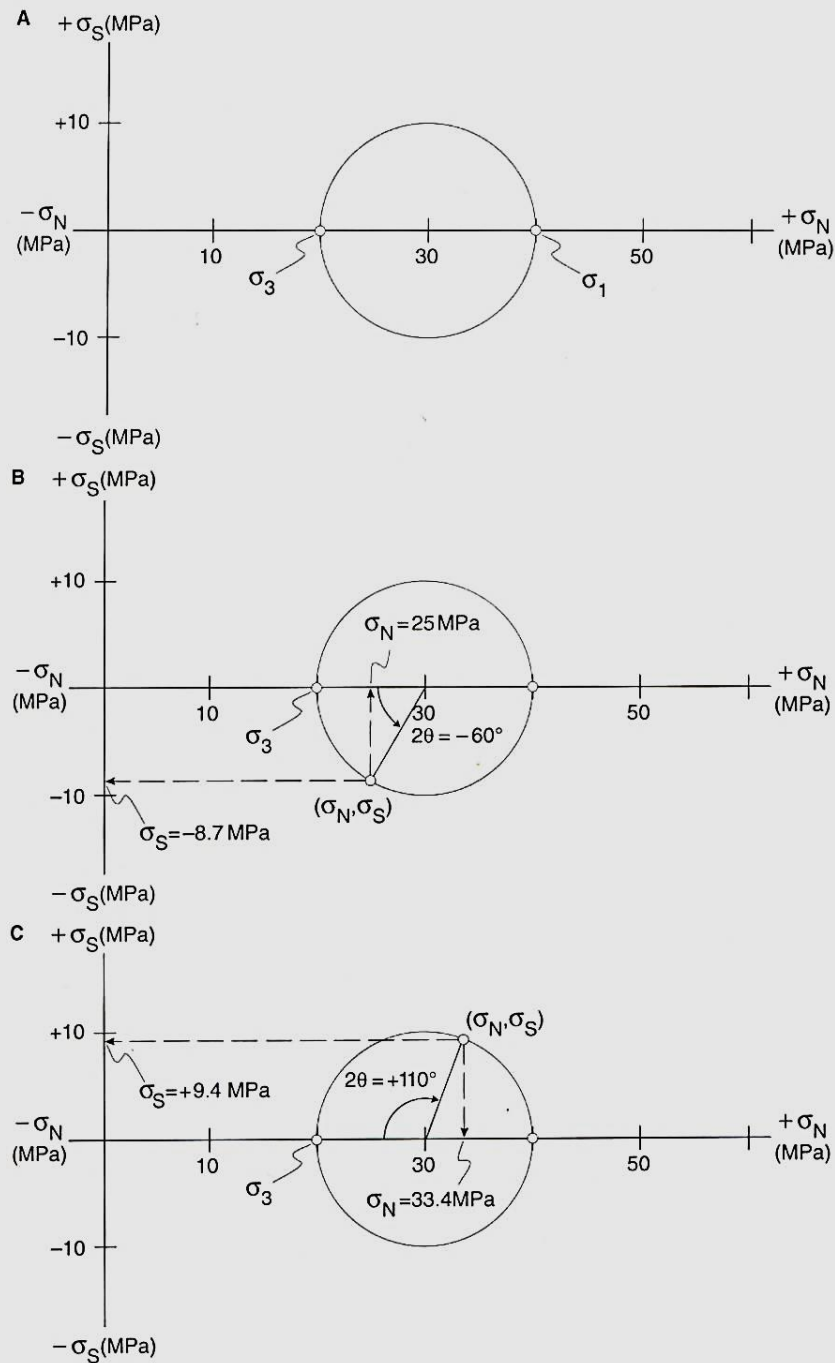
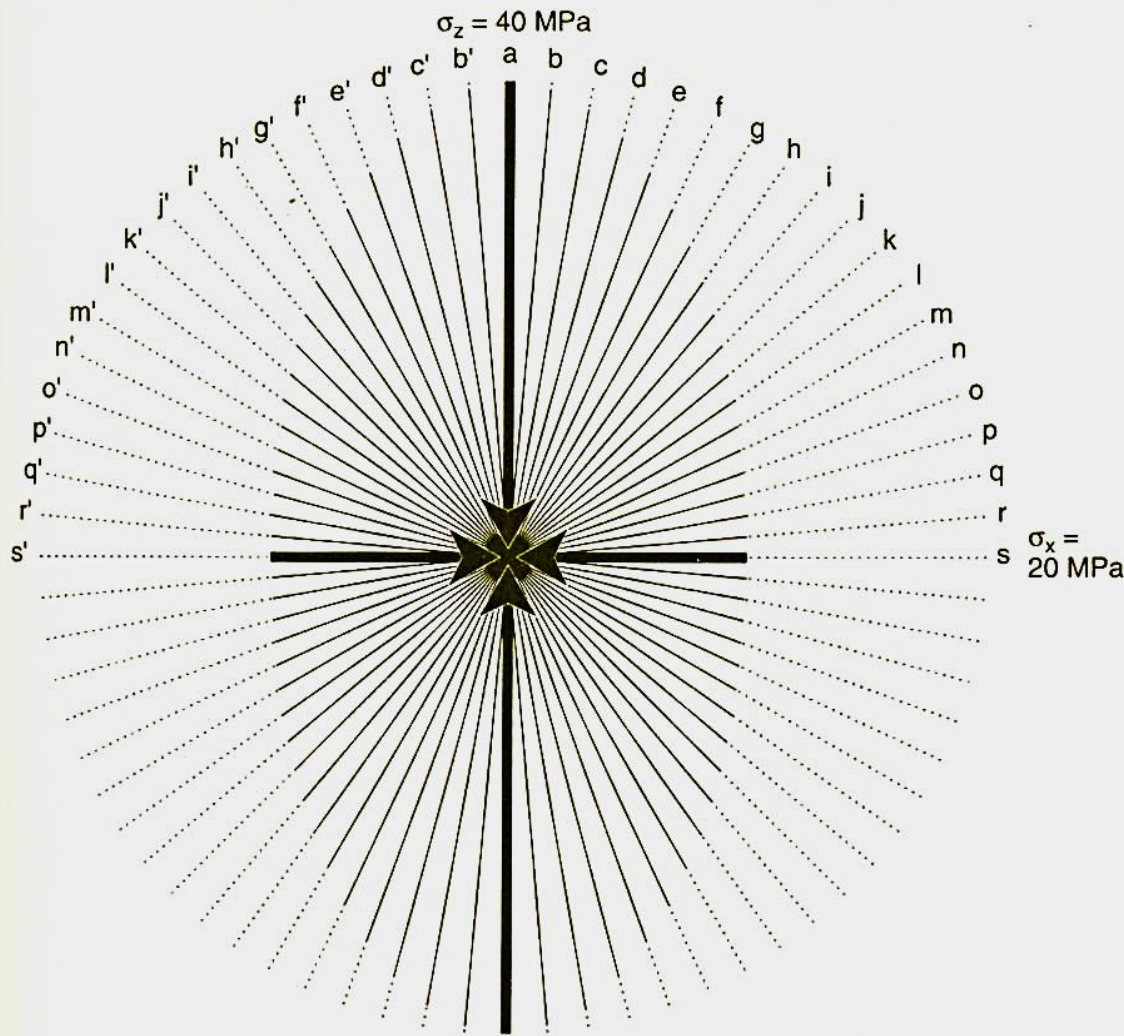

Figure 3.23 Construction of a Mohr stress circle. (A) Plot greatest (σ_1) and least (σ_3) principal stresses within x - y coordinate system. Normal stresses (σ_N) are plotted along x -axis; shear stresses (σ_S) are plotted along y -axis. Construct circle that passes through the principal stress values. Center of circle lies along the x -axis. (B) Determine the normal stress (σ_N) and shear stress (σ_S) values for a plane that makes an angle of $\theta = -30^\circ$ with respect to the direction of greatest principal stress (σ_1). Do this by constructing an angle of -60° (counterclockwise) from the x -axis. The intersection of the radius with the circle yields a point whose (x,y) coordinates are (σ_N, σ_S) . (C) In this example the (σ_N, σ_S) values are found for a plane that makes an angle of $\theta = +55^\circ$ with the direction of greatest principal stress (σ_1).



Plane	\angle to Z	σ (MPa) 20	σ_N (MPa) 20	σ_S (MPa) 20
a	0°	20.00	20.00	0.00
b	-5°	20.23	20.15	-1.47
c	-10°	20.89	20.60	-3.42
d	-15°	21.92	21.34	-5.00
e	-20°	23.25	22.34	-6.43
f	-25°	24.79	23.57	-7.66
g	-30°	26.46	25.00	-8.66
h	-35°	28.19	26.58	-9.40
i	-40°	29.93	28.26	-9.85
j	-45°	31.62	30.00	-10.00
k	-50°	33.23	31.74	-9.85
l	-55°	34.72	33.42	-9.40
m	-60°	36.06	35.00	-8.66
n	-65°	37.22	36.43	-7.66
o	-70°	38.21	37.66	-6.43
p	-75°	38.98	38.66	-5.00
q	-80°	39.55	39.40	-3.42
r	-85°	39.89	39.85	-1.74
s	-90°	40.00	40.00	0.00
a'	0°	20.00	20.00	0.00
b'	5°	20.23	20.15	1.47
c'	10°	20.89	20.60	3.42
d'	15°	21.92	21.34	5.00
e'	20°	23.25	22.34	6.43
f'	25°	24.79	23.57	7.66
g'	30°	26.46	25.00	8.66
h'	35°	28.19	26.58	9.40
i'	40°	29.93	28.26	9.85
j'	45°	31.62	30.00	10.00
k'	50°	33.23	31.74	9.85
l'	55°	34.72	33.42	9.40
m'	60°	36.06	35.00	8.66
n'	65°	37.22	36.43	7.66
o'	70°	38.21	37.66	6.43
p'	75°	38.98	38.66	5.00
q'	80°	39.55	39.40	3.42
r'	85°	39.89	39.85	1.74
s'	90°	40.00	40.00	0.00

Figure 3.17 Pictured here is a vertical stress (σ_z) of magnitude 40 MPa and a horizontal stress (σ_x) of magnitude 20 MPa. The lines labeled a–s and b' to r' are traces of planes at 5° intervals. Stress (σ), normal stress (σ_N), and shear stress (σ_S) have been calculated for each of the planes to show the systematic variations.

To define σ_N and σ_S for a specific plane (e.g., a plane oriented at $\theta = -30^\circ$ *counterclockwise* from the plane to σ_1) (**Figure 3.23B**), a radius is constructed on the Mohr stress diagram at an angle of 2θ , or -60° , measured *counterclockwise* from the x-axis (**Figure 3.23B**).

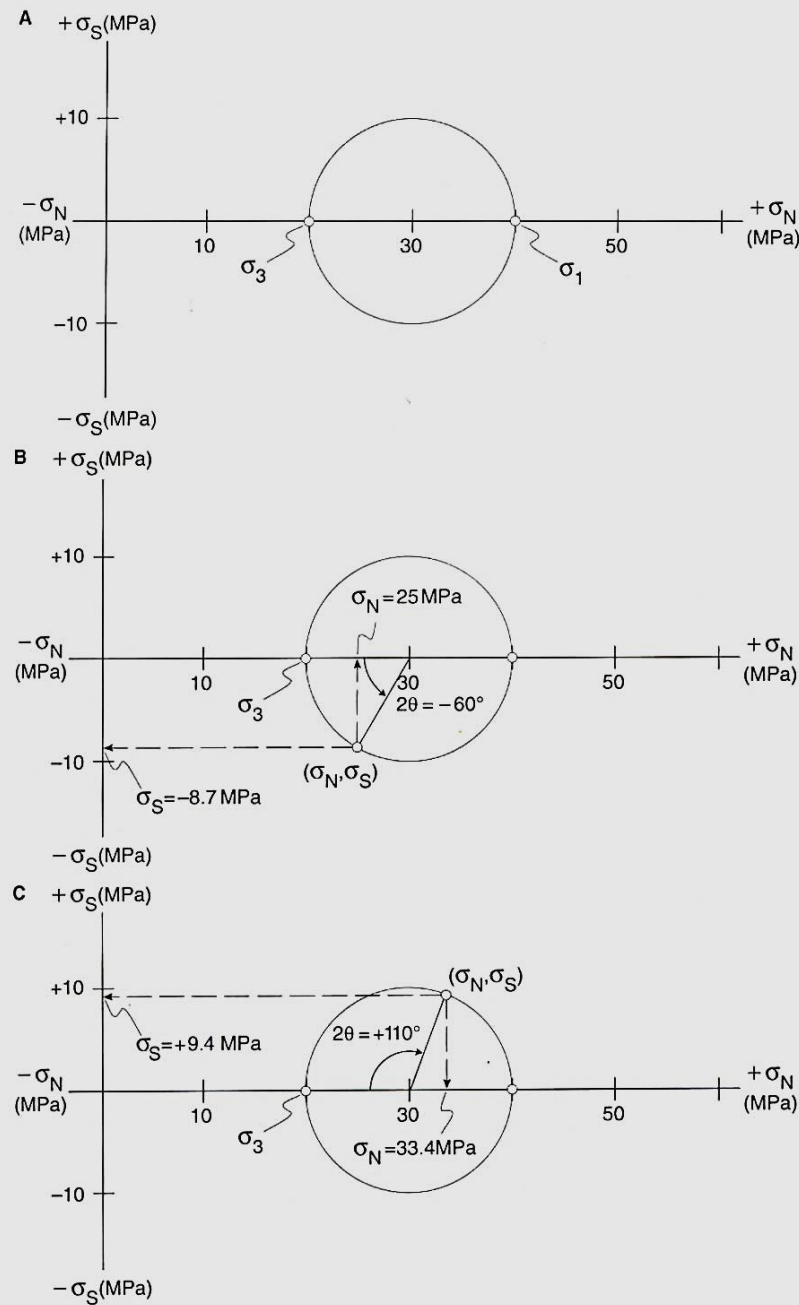

Figure 3.23 Construction of a Mohr stress circle. (A) Plot greatest (σ_1) and least (σ_3) principal stresses within x - y coordinate system. Normal stresses (σ_N) are plotted along x -axis; shear stresses (σ_S) are plotted along y -axis. Construct circle that passes through the principal stress values. Center of circle lies along the x -axis. (B) Determine the normal stress (σ_N) and shear stress (σ_S) values for a plane that makes an angle of $\theta = -30^\circ$ with respect to the direction of greatest principal stress (σ_1). Do this by constructing an angle of -60° (counterclockwise) from the x -axis. The intersection of the radius with the circle yields a point whose (x, y) coordinates are (σ_N, σ_S) . (C) In this example the (σ_N, σ_S) values are found for a plane that makes an angle of $\theta = +55^\circ$ with the direction of greatest principal stress (σ_1).

Where this radius intersects the perimeter of the circle, a point is established whose x, y coordinates are the (σ_N, σ_S) values for the plane in question: $\sigma_N = +25$ MPa and $\sigma_S = -8.6$ MPa (left-handed).

The values of σ_N and σ_S for a plane oriented $+55^\circ$ to σ_1 are found by constructing a radius at an angle of $2\theta = +110^\circ$, this time measured clockwise from the x -axis (**Figure 3.23C**).

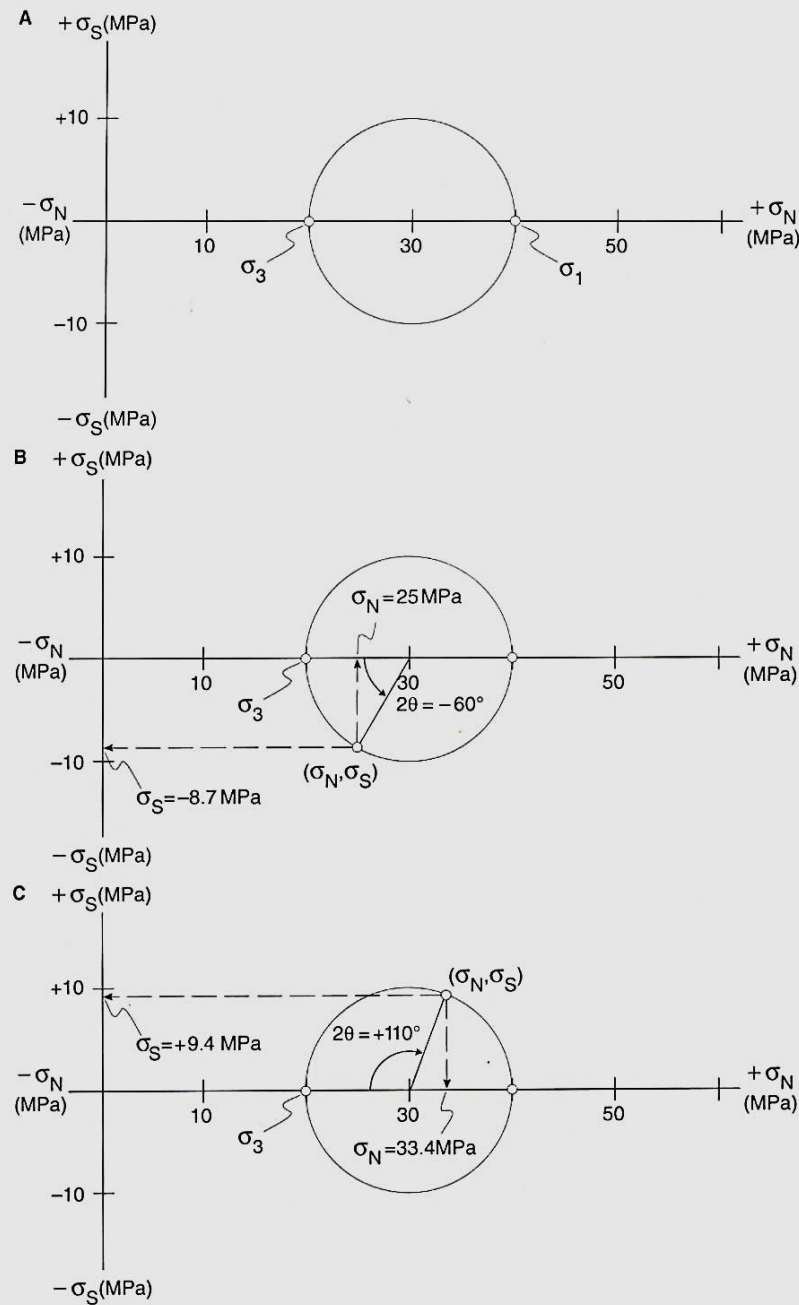

Figure 3.23 Construction of a Mohr stress circle. (A) Plot greatest (σ_1) and least (σ_3) principal stresses within x - y coordinate system. Normal stresses (σ_N) are plotted along x -axis; shear stresses (σ_S) are plotted along y -axis. Construct circle that passes through the principal stress values. Center of circle lies along the x -axis. (B) Determine the normal stress (σ_N) and shear stress (σ_S) values for a plane that makes an angle of $\theta = -30^\circ$ with respect to the direction of greatest principal stress (σ_1). Do this by constructing an angle of -60° (counterclockwise) from the x -axis. The intersection of the radius with the circle yields a point whose (x, y) coordinates are (σ_N, σ_S) . (C) In this example the (σ_N, σ_S) values are found for a plane that makes an angle of $\theta = +55^\circ$ with the direction of greatest principal stress (σ_1).

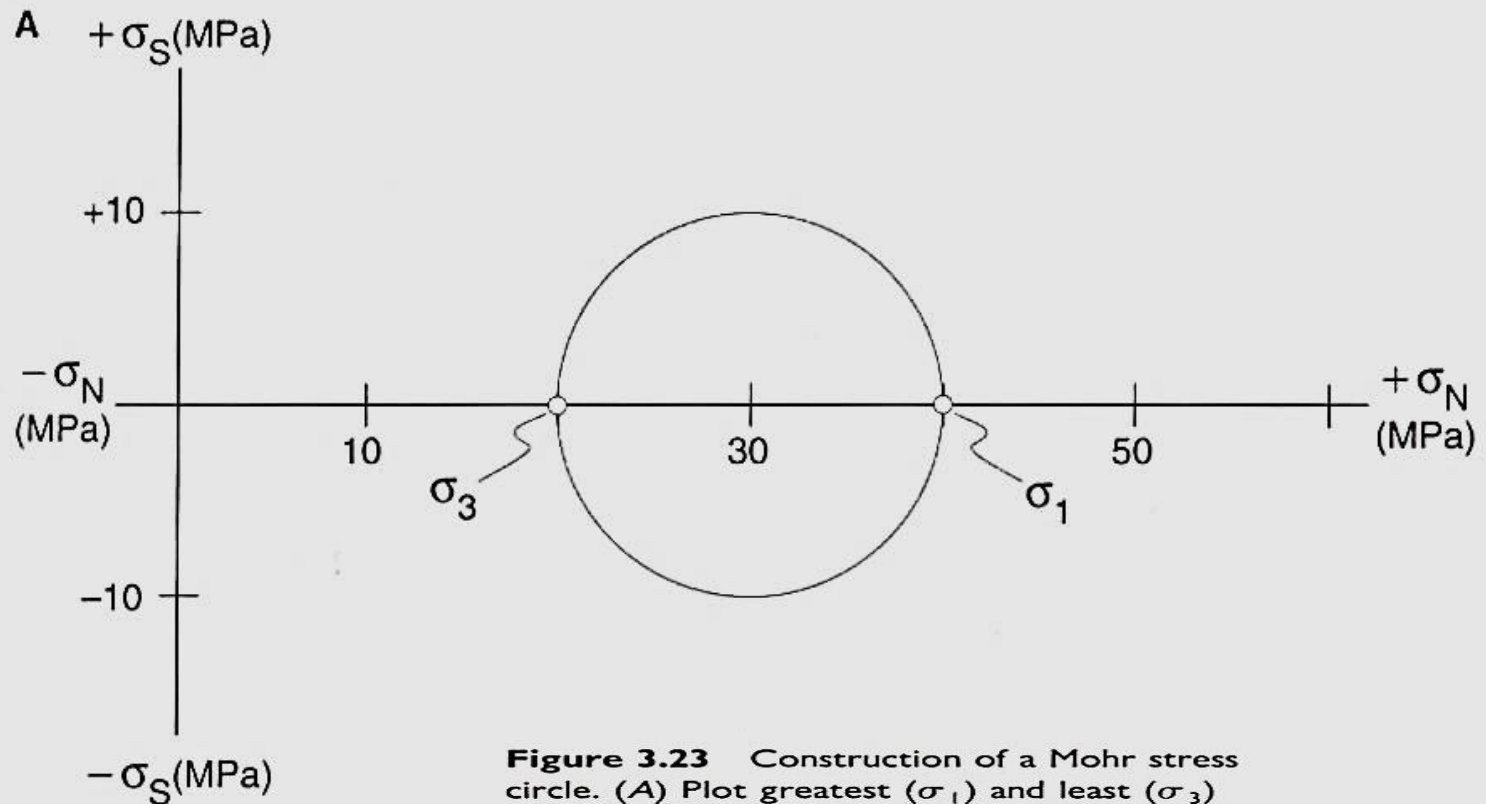

Figure 3.23 Construction of a Mohr stress circle. (A) Plot greatest (σ_1) and least (σ_3) principal stresses within x - y coordinate system. Normal stresses (σ_N) are plotted along x -axis; shear stresses (σ_S) are plotted along y -axis. Construct circle that passes through the principal stress values. Center of circle lies along the x -axis. (B) Determine the normal stress (σ_N) and shear stress (σ_S) values for a plane that makes an angle of $\theta = -30^\circ$ with respect to the direction of greatest principal stress (σ_1). Do this by constructing an angle of -60° (counterclockwise) from the x -axis. The intersection of the radius with the circle yields a point whose (x,y) coordinates are (σ_N, σ_S) . (C) In this example the (σ_N, σ_S) values are found for a plane that makes an angle of $\theta = +55^\circ$ with the direction of greatest principal stress (σ_1).

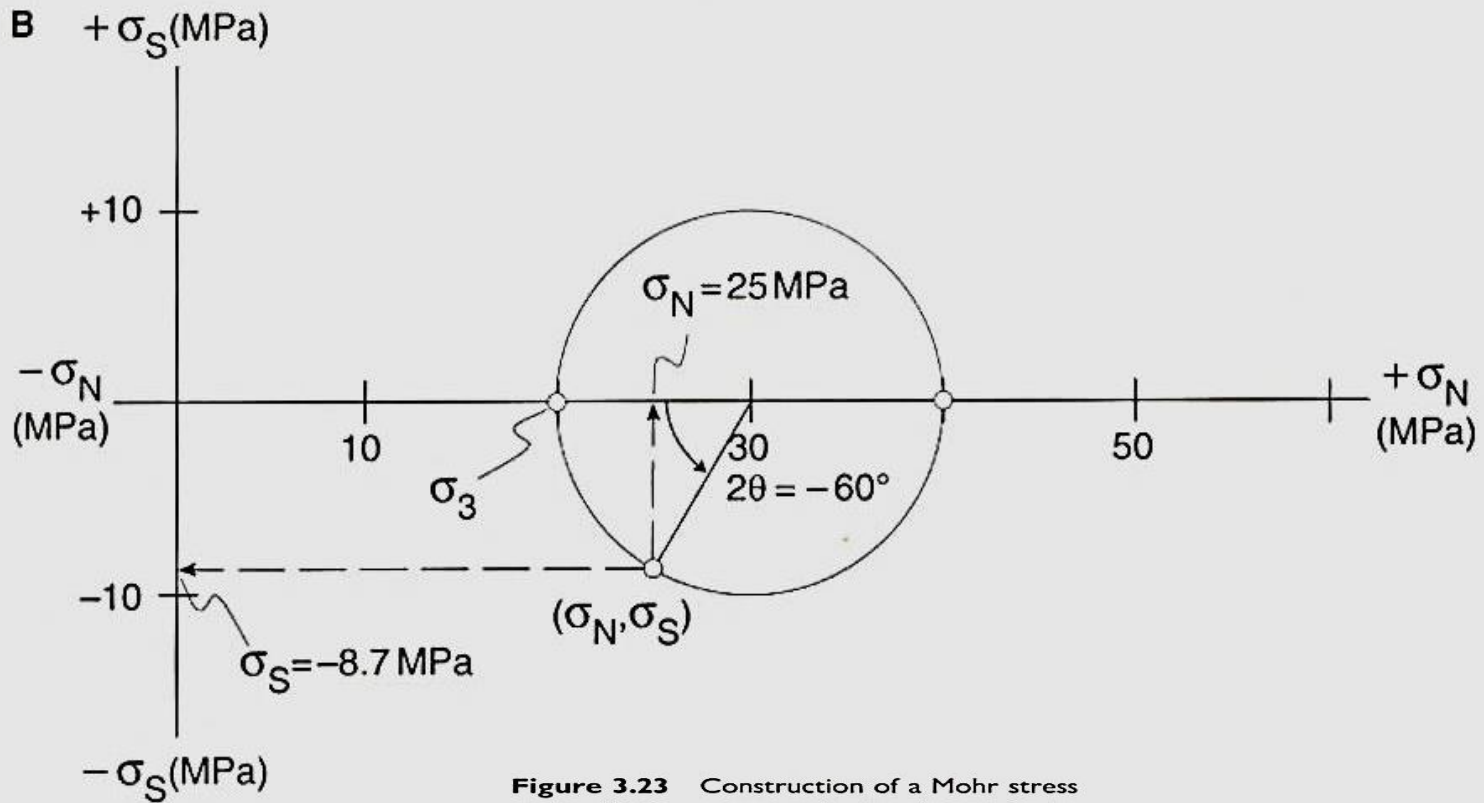

Figure 3.23 Construction of a Mohr stress circle. (A) Plot greatest (σ_1) and least (σ_3) principal stresses within x - y coordinate system. Normal stresses (σ_N) are plotted along x -axis; shear stresses (σ_S) are plotted along y -axis. Construct circle that passes through the principal stress values. Center of circle lies along the x -axis. (B) Determine the normal stress (σ_N) and shear stress (σ_S) values for a plane that makes an angle of $\theta = -30^\circ$ with respect to the direction of greatest principal stress (σ_1). Do this by constructing an angle of -60° (counterclockwise) from the x -axis. The intersection of the radius with the circle yields a point whose (x,y) coordinates are (σ_N, σ_S) . (C) In this example the (σ_N, σ_S) values are found for a plane that makes an angle of $\theta = +55^\circ$ with the direction of greatest principal stress (σ_1).

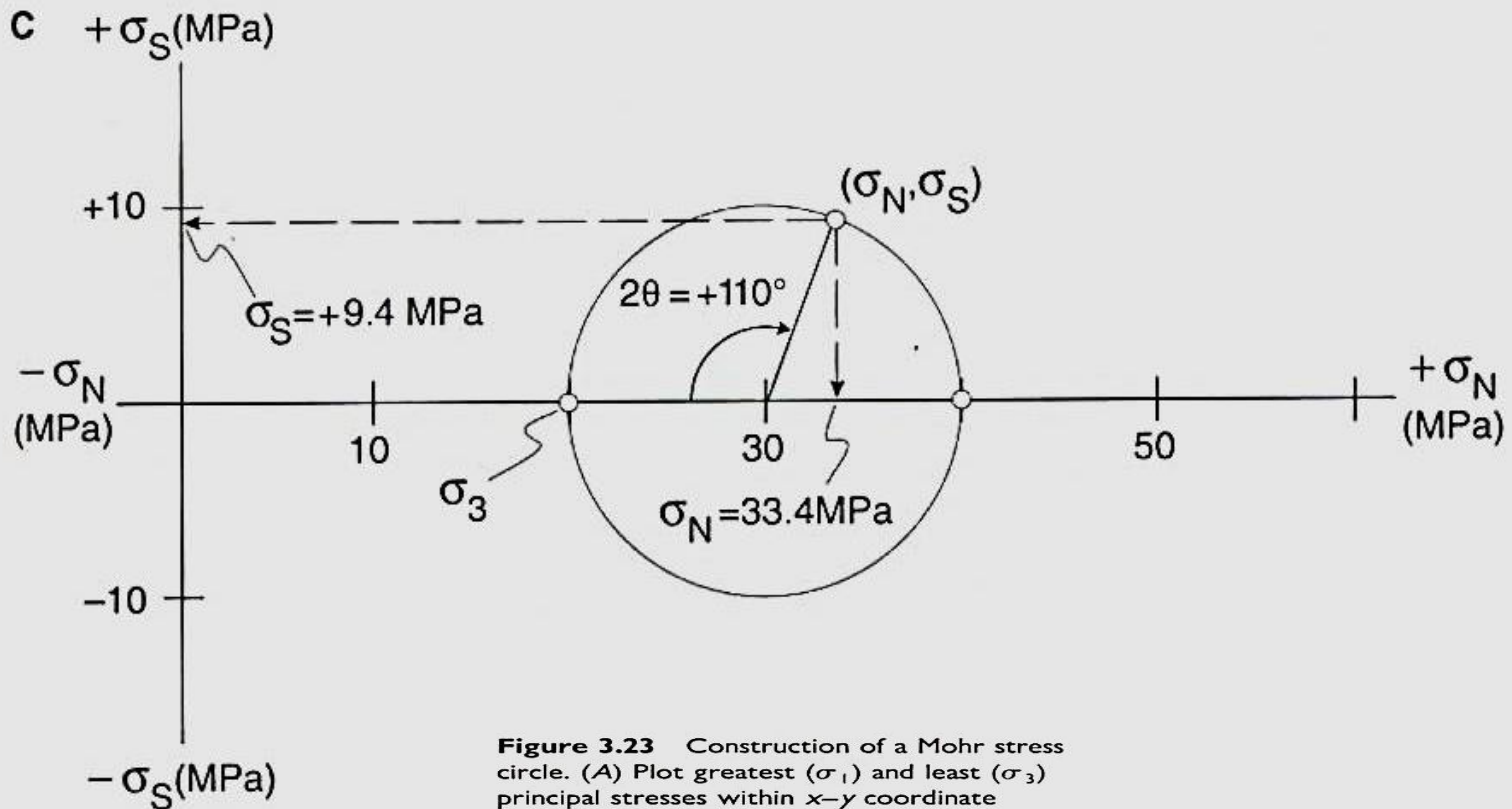

Figure 3.23 Construction of a Mohr stress circle. (A) Plot greatest (σ_1) and least (σ_3) principal stresses within x - y coordinate system. Normal stresses (σ_N) are plotted along x -axis; shear stresses (σ_S) are plotted along y -axis. Construct circle that passes through the principal stress values. Center of circle lies along the x -axis. (B) Determine the normal stress (σ_N) and shear stress (σ_S) values for a plane that makes an angle of $\theta = -30^\circ$ with respect to the direction of greatest principal stress (σ_1). Do this by constructing an angle of -60° (counterclockwise) from the x -axis. The intersection of the radius with the circle yields a point whose (x,y) coordinates are (σ_N, σ_S) . (C) In this example the (σ_N, σ_S) values are found for a plane that makes an angle of $\theta = +55^\circ$ with the direction of greatest principal stress (σ_1).

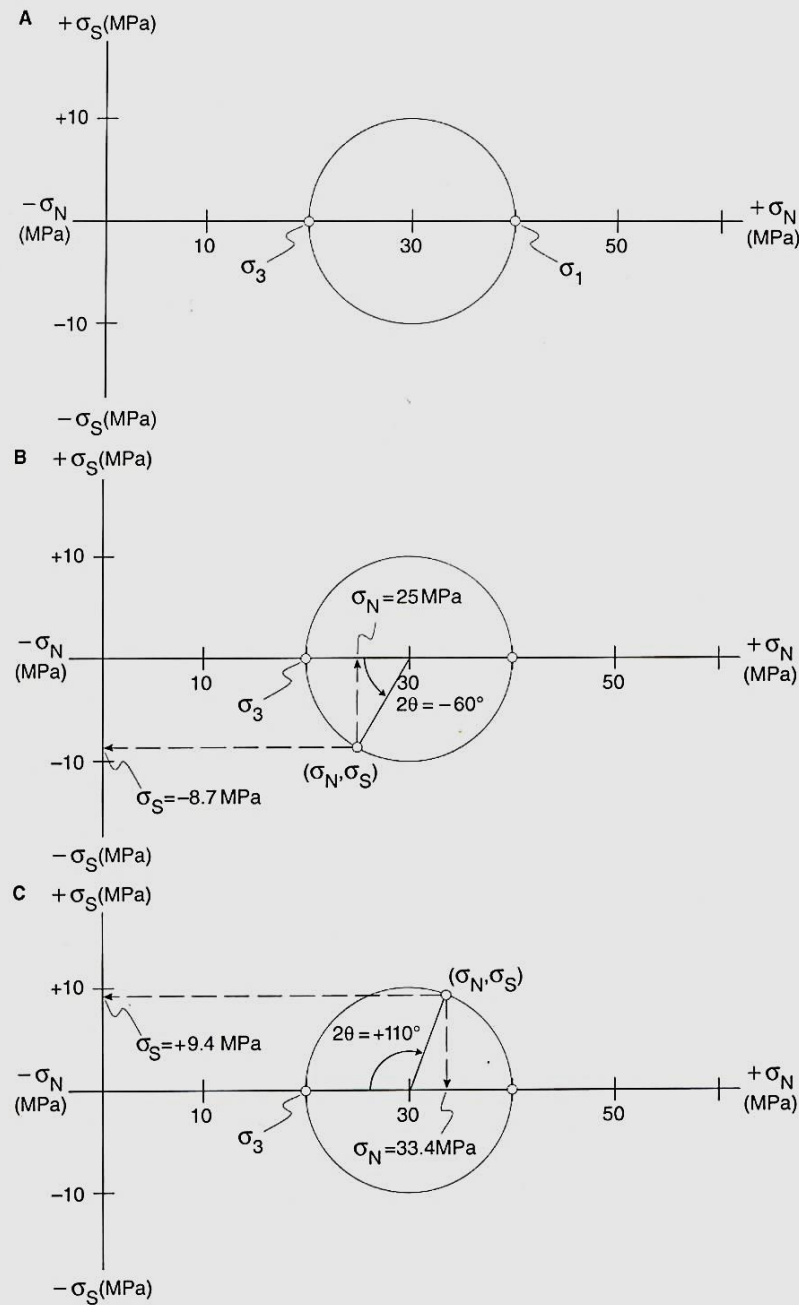

Figure 3.23 Construction of a Mohr stress circle. (A) Plot greatest (σ_1) and least (σ_3) principal stresses within x - y coordinate system. Normal stresses (σ_N) are plotted along x -axis; shear stresses (σ_S) are plotted along y -axis. Construct circle that passes through the principal stress values. Center of circle lies along the x -axis. (B) Determine the normal stress (σ_N) and shear stress (σ_S) values for a plane that makes an angle of $\theta = -30^\circ$ with respect to the direction of greatest principal stress (σ_1). Do this by constructing an angle of -60° (counterclockwise) from the x -axis. The intersection of the radius with the circle yields a point whose (x, y) coordinates are (σ_N, σ_S) . (C) In this example the (σ_N, σ_S) values are found for a plane that makes an angle of $\theta = +55^\circ$ with the direction of greatest principal stress (σ_1).

Where the principal stresses are σ_1 and σ_2 the equations for the normal and shear stresses across a plane whose normal is inclined **at θ to σ_1** are:

$$\sigma_N = \frac{1}{2} (\sigma_1 + \sigma_3) + \frac{1}{2} (\sigma_1 - \sigma_3) \cos 2 \theta$$

$$\sigma_S = \frac{1}{2} (\sigma_1 - \sigma_3) \sin 2 \theta \quad (1.7)$$

The x,y coordinates of the point of intersection of this radius with the perimeter of the circle are $\sigma_N = + 33.4$ MPa and $\sigma_S = + 9.4$ MPa (right-handed).

The anatomy of the Mohr diagram is revealing (**Figure 3.24**). The center of the Mohr stress circle is a point that represents the mean stress, that is, $(\sigma_1 + \sigma_3)/2$. This is the hydrostatic component of the principal stresses, and it tends to produce dilation.

Figure 3.24 The center of the Mohr stress circle represents mean stress, which is the hydrostatic component of the stress field. Mean stress tends to produce dilation. The radius of the Mohr stress circle represents deviatoric stress, which is the nonhydrostatic component of the stress field. Deviatoric stress tends to produce distortion. The diameter of the Mohr stress circle represents differential stress. The larger it is, the greater the potential for distortion.

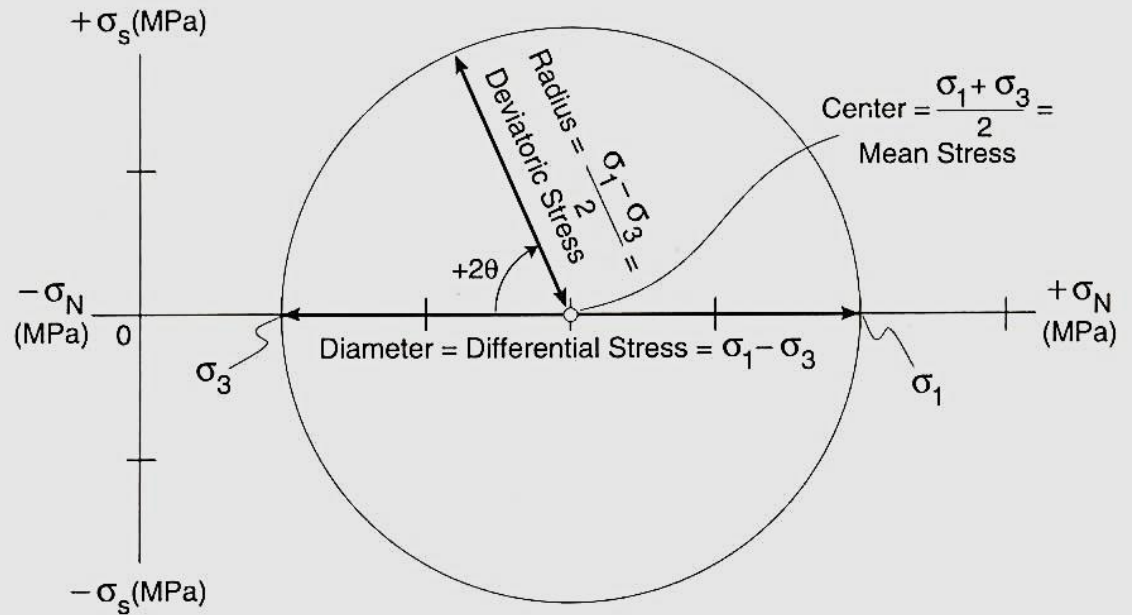

Shear stress

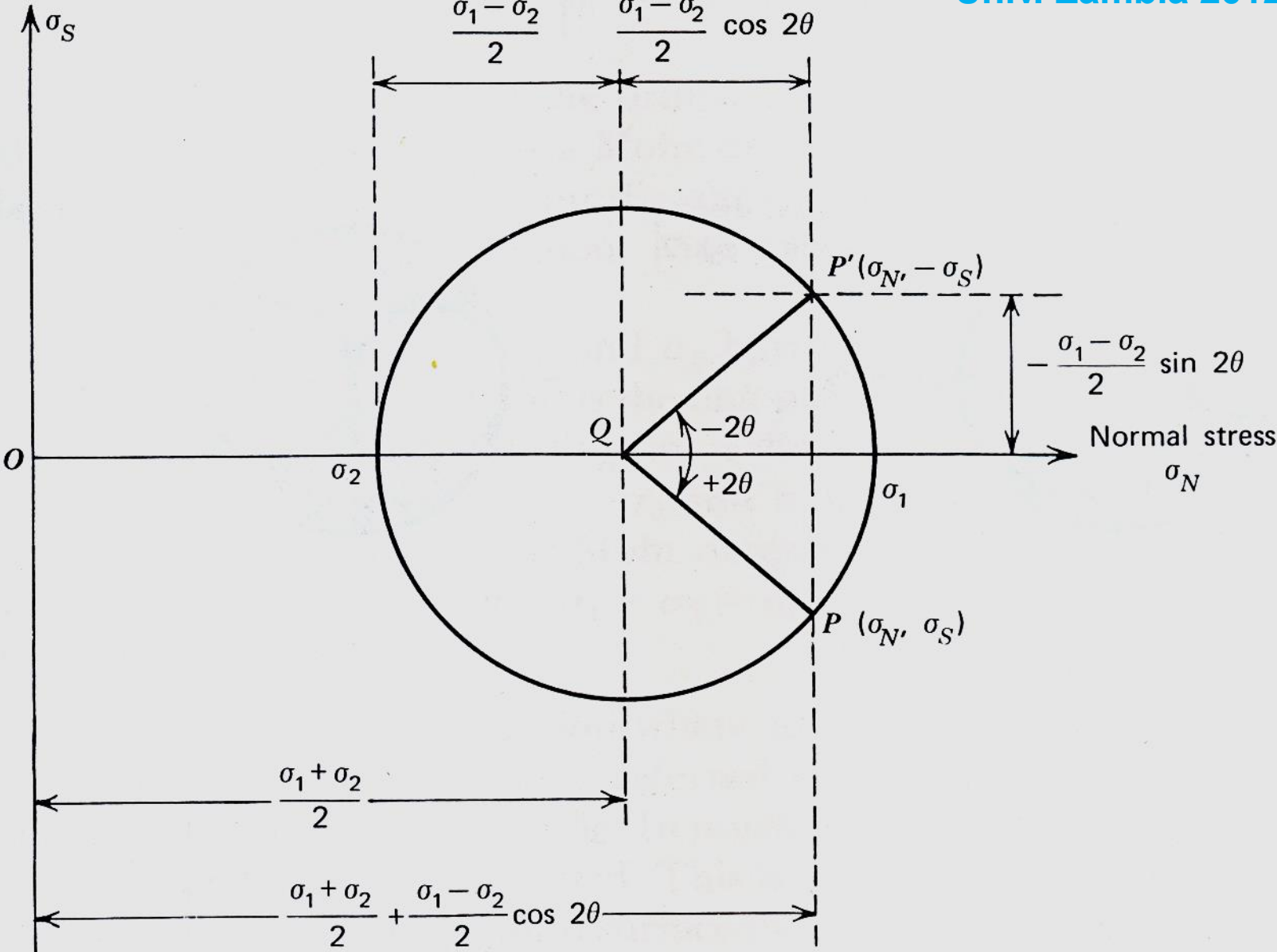

(a)

The radius of the circle represents the deviatoric stress, that is, $(\sigma_1 - \sigma_3)/2$. The deviatoric stress is the nonhydrostatic component, and it tends to produce distortion.

The diameter of the circle is called the differential stress, that is, $\sigma_1 - \sigma_3$. The greater it is, the greater the potential for distortion.

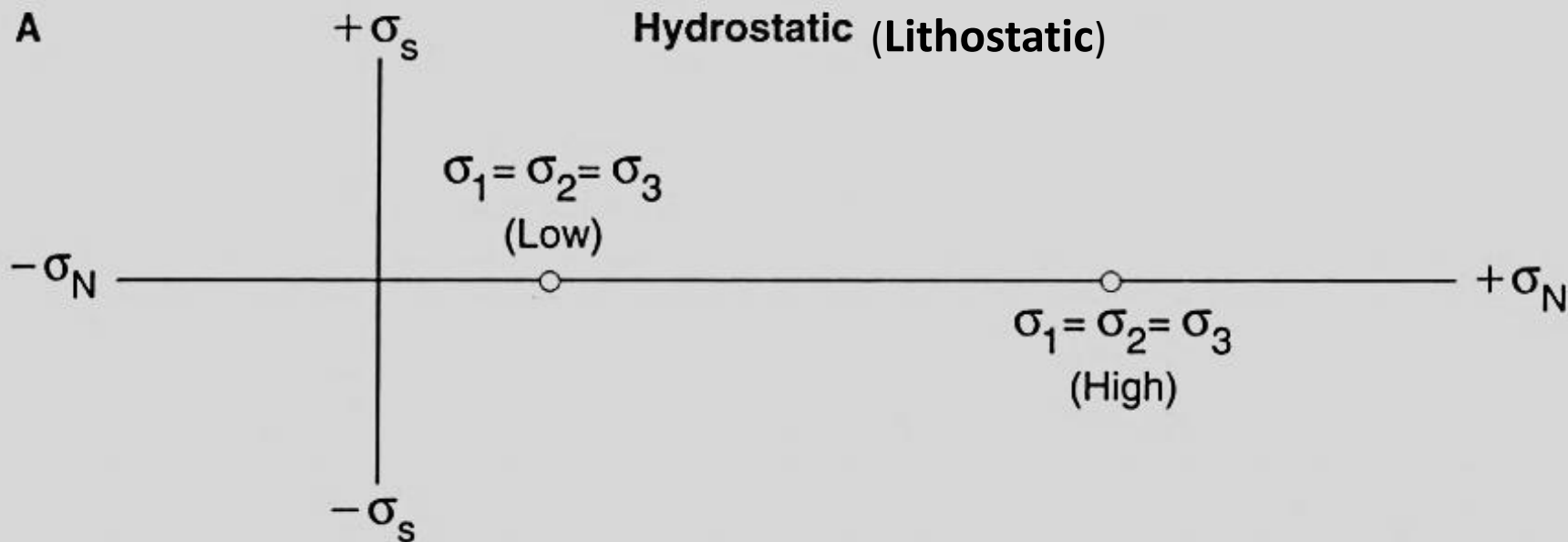

Figure 3.25 Various states of stress can be represented on the Mohr stress diagram: (A) hydrostatic stress, (B) uniaxial stress, (C) axial stress, and (D) triaxial stress.

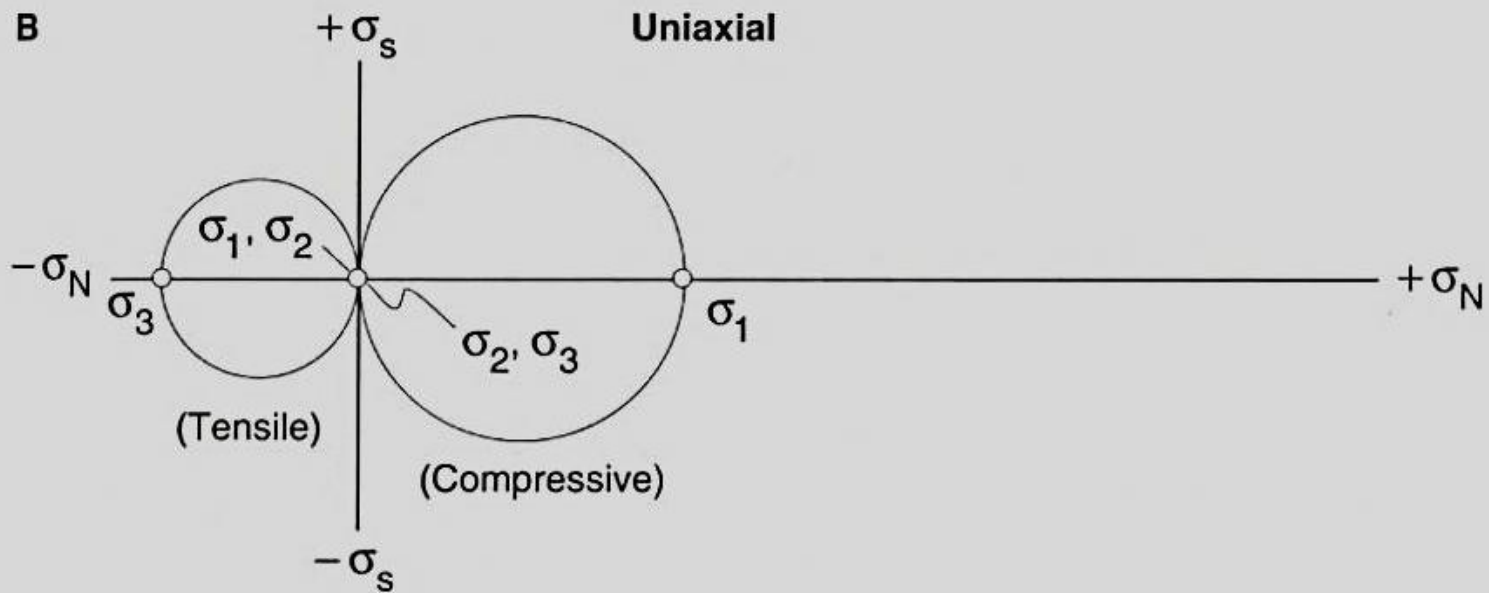

Figure 3.25 Various states of stress can be represented on the Mohr stress diagram: (A) hydrostatic stress, (B) uniaxial stress, (C) axial stress, and (D) triaxial stress.

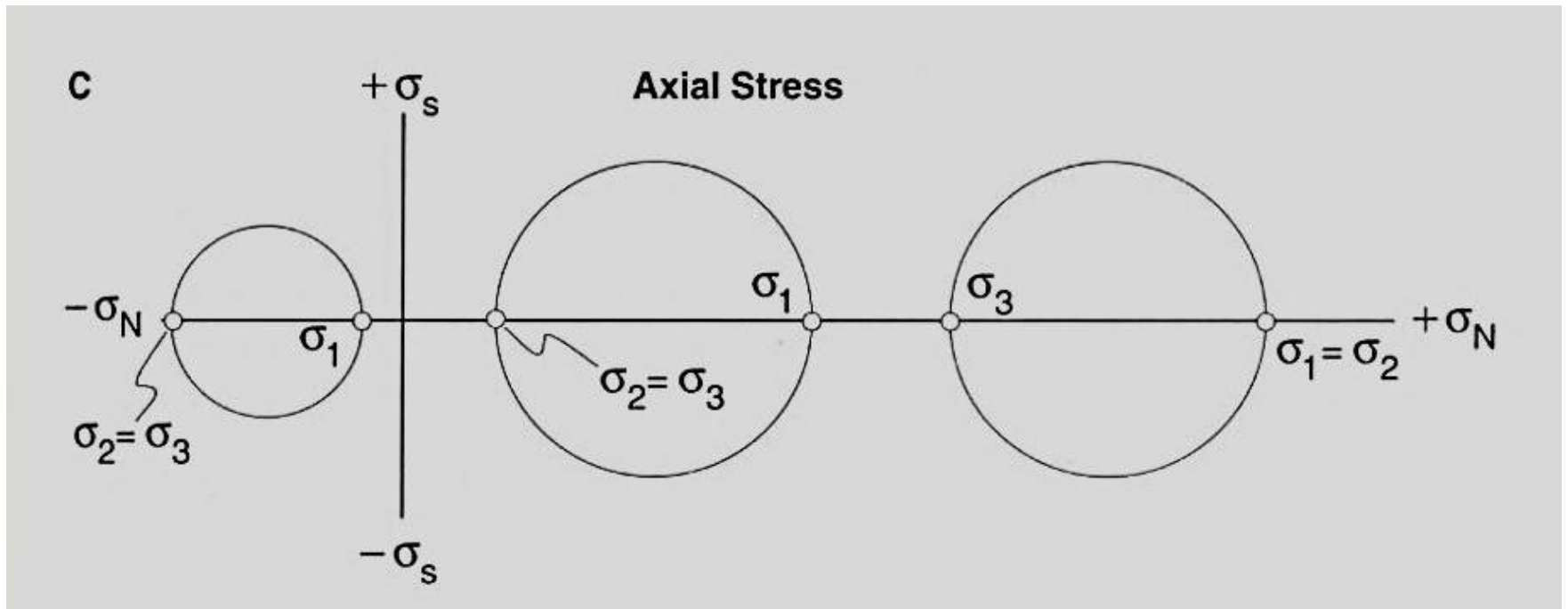

Figure 3.25 Various states of stress can be represented on the Mohr stress diagram: (A) hydrostatic stress, (B) uniaxial stress, (C) axial stress, and (D) triaxial stress.

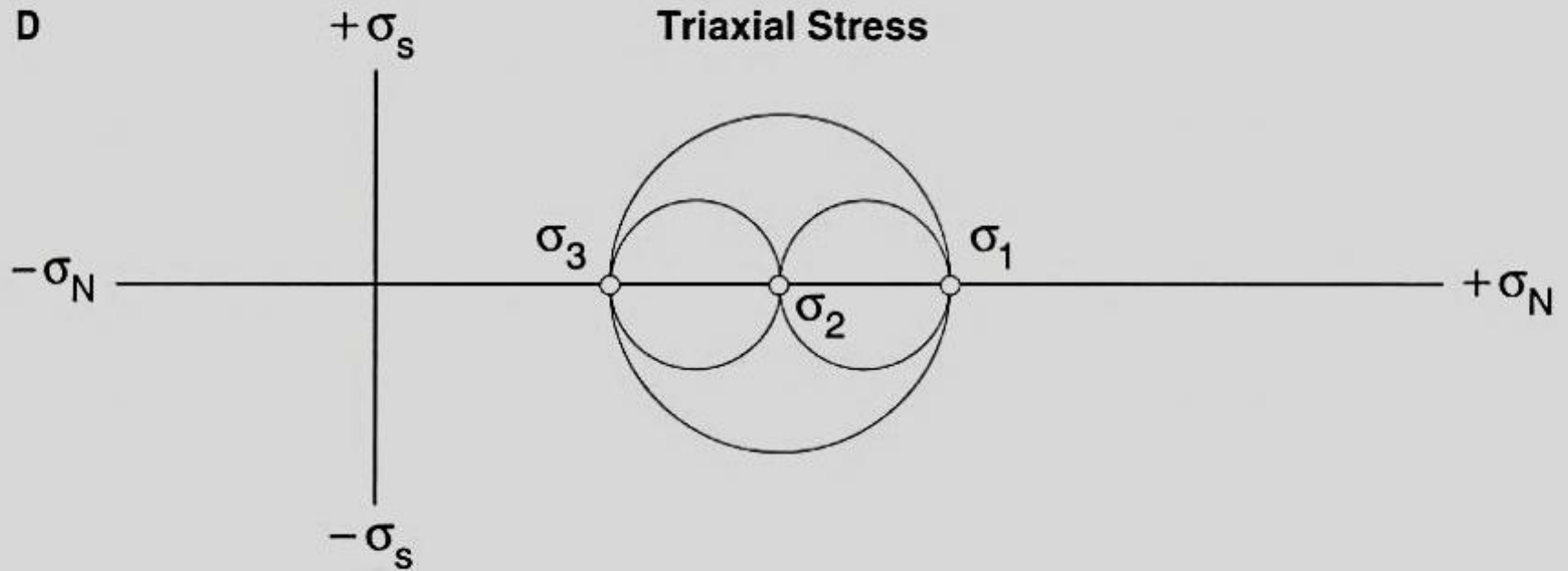

Figure 3.25 Various states of stress can be represented on the Mohr stress diagram: (A) hydrostatic stress, (B) uniaxial stress, (C) axial stress, and (D) triaxial stress.

Construction of the Mohr Circle

- Multiply the physical angle θ by 2
- The angle 2θ is from the σ_1 line to any point on the circle
- **+ 2θ (counterclockwise) angles are read above the x-axis**
- **- 2θ (clockwise) angles below the x-axis, from the σ_1 axis**
- The σ_N and σ_S of a point on the circle represent the normal and shear stresses on the plane with the given 2θ angle

NOTE: *The axes of the Mohr circle have no geographic significance!*

Shear stress

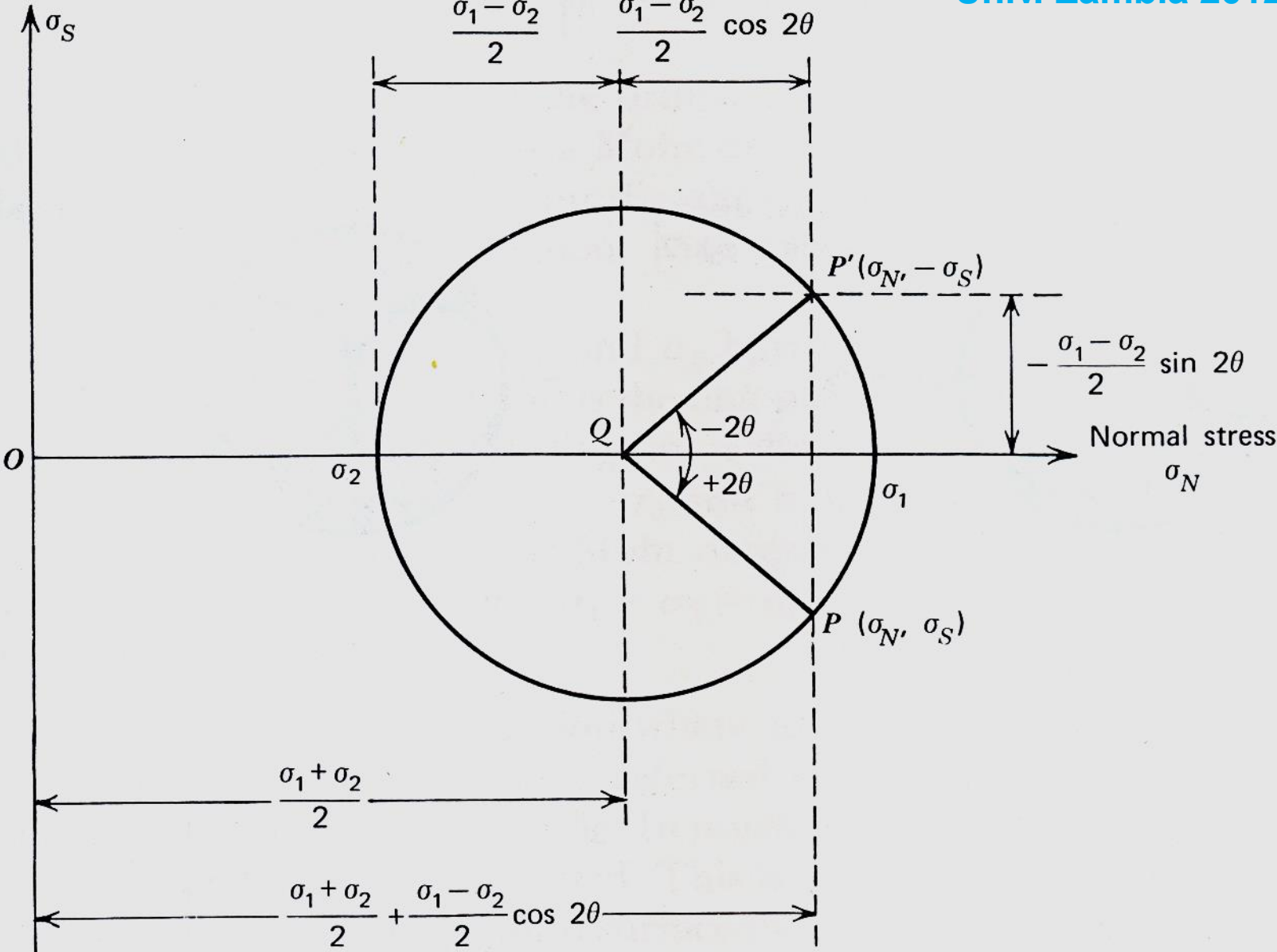

(a)

Figure 3.24 The center of the Mohr stress circle represents mean stress, which is the hydrostatic component of the stress field. Mean stress tends to produce dilation. The radius of the Mohr stress circle represents deviatoric stress, which is the nonhydrostatic component of the stress field. Deviatoric stress tends to produce distortion. The diameter of the Mohr stress circle represents differential stress. The larger it is, the greater the potential for distortion.

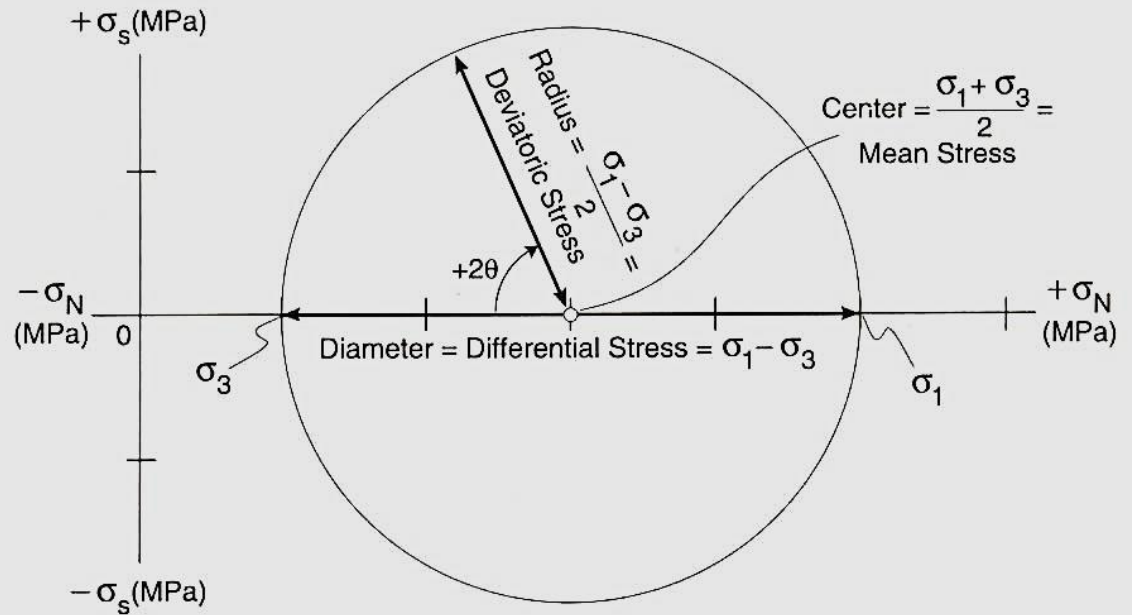

Construction of the Mohr Circle in 2D

- Plot the normal stress, σ_n , vs. shear stress, σ_s , on a graph paper using arbitrary scale (e.g., mm scale!)
- Calculate:
 - Center $c = (\sigma_1 + \sigma_3)/2$
 - Radius $r = (\sigma_1 - \sigma_3)/2$
- **Note: Diameter is the differential stress** ($\sigma_1 - \sigma_3$)
- The circle intersects the σ_n (x-axis) at the two principal stresses (σ_1 and σ_3)