

INTRODUCTION TO STEREOGRAPHIC PROJECTIONS:

The Concept

Lecturer: D. Zilifi

derrick.zilifi@unza.zm

Introduction to concepts

Introduction to the concept

- **Representation and manipulation** of structural data by **geometric methods** becomes cumbersome and difficult if we have to analyze a large number of measurements.

Introduction to the concepts cont'd

- The **concept of stereographic projection**, provides a **simple** and **quick** alternative way to represent **three-dimensional** data in **two dimensions**.
- This has become **widely used by structural geologists** during the last **50 years**.

Introduction to the concepts cont'd

- Data plotting using a stereographic projection may **seem abstract at first,**
- Once you are used to it you will find that the **methods are powerful** and **allow you to solve many types of structural problems easily.**

Introduction to the concepts cont'd

- **Computers** are increasingly being used to plot structural data on stereographic projections,
- **But you will not be able to interpret computer output if you are not adept at plotting data by hand.**

Introduction to the concept cont'd

- **In fact**, you will find that the **cardboard stereonet** itself is **versatile, quick** and
- **Can easily be carried with you to the field**, even in a remote area.

Concept of Stereographic Projection

Concept of Stereographic Projection

- A **spherical surface** on which **positions** are indicated is called a *spherical projection*.
- **Only orientations, not distances,** can be represented **on spherical projections!**

Concept of Stereographic Projection cont'd

- **Spherical projections** can be used to represent the **orientations** of a **line** or a **plane**, if the line or plane is positioned so that it passes through the center of the sphere.

Concept of Stereographic Projection cont'd

- A **line** that is so positioned intersects the surface of the **sphere** at **two points**, and
- A **plane** that is so positioned intersects the surface of the **sphere along a circle** (Fig. 5-1).
- The **intersection** of the **line** or **plane** with the surface of the sphere is its **spherical projection**.

Concept of Stereographic Projection cont'd

- **Fig. 5-1. Spherical projections of lines and planes.**
- Any **line** through the centre of the sphere **pierces the sphere at two points.**
- Any plane through the centre of the sphere **intersects the sphere along a circle.**

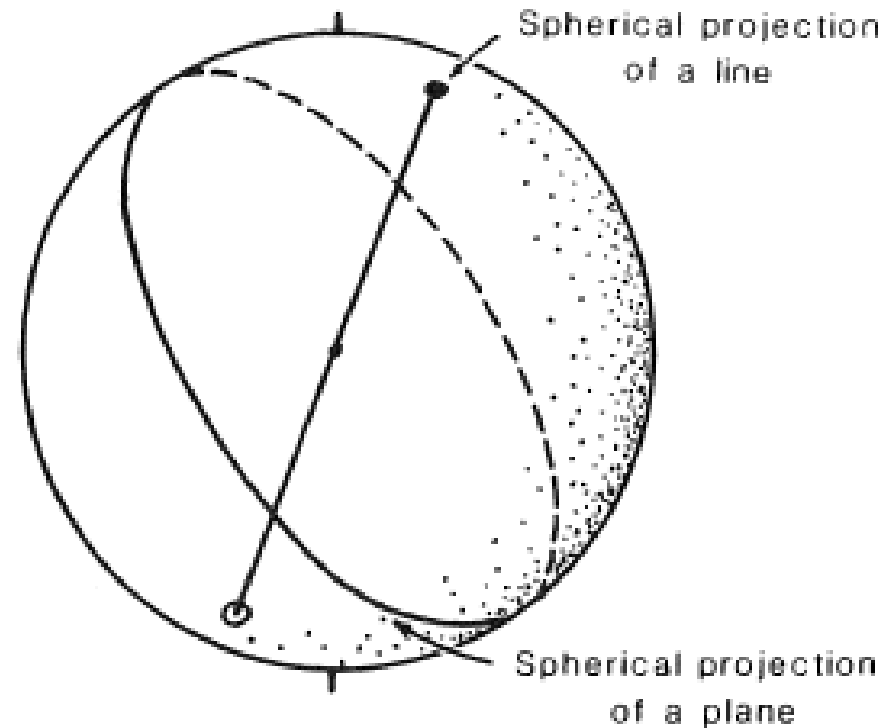

Concept of Stereographic Projection cont'd

- A spherical projection is three dimensional and is, therefore, **not particularly portable.**
- **Fortunately,** a sphere can be projected onto a **two-dimensional plane.**
- The most common planar projections of a sphere are called ***azimuthal projections.***

Concept of Stereographic Projection cont'd

- An *azimuthal* projection is constructed by passing projection lines from a point source through the sphere to where they intersect a projection plane:
 - Imagine that the point source is a small light bulb; **Fig. 5.2.**

Concept of Stereographic Projection cont'd

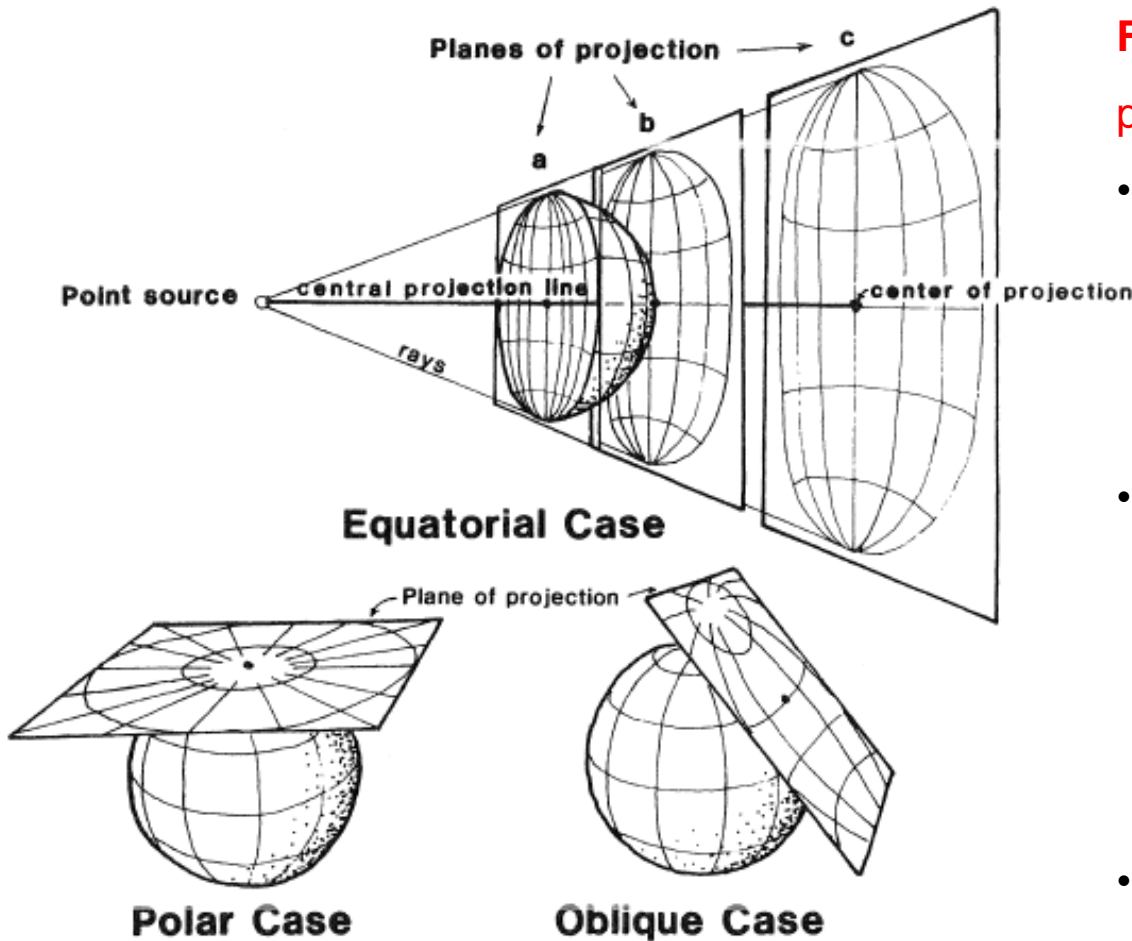

Fig.5-2. Three different azimuthal projections.

- The projections vary according to the **position of the point source** with respect to the sphere.
- The size of the projection depends on the relative distances among the **point source**, the **sphere**, and the **projection plane**.
- The **orientation of the projection plane** determines the type of projection.

Concept of Stereographic Projection cont'd

- The **plane must be oriented** such that the unique projection line that passes through the center of the sphere (**the *central projection line***) is **perpendicular to the projection plane**.

Concept of Stereographic Projection cont'd

- The projection plane can be **tangent** to the surface of the sphere, or
- It can be **at a distance** from the surface of the sphere, or
- It can **pass through the center** of the sphere.

Concept of Stereographic Projection cont'd

- A change in the position of the projection plane merely changes the scale of the projection (**Fig. 5-2**).
- A projection plane **can also have any orientation**, and this
- Determines whether the projection is an **equatorial, polar, or oblique** one (**Fig. 5-2**).

Fig. 5.2

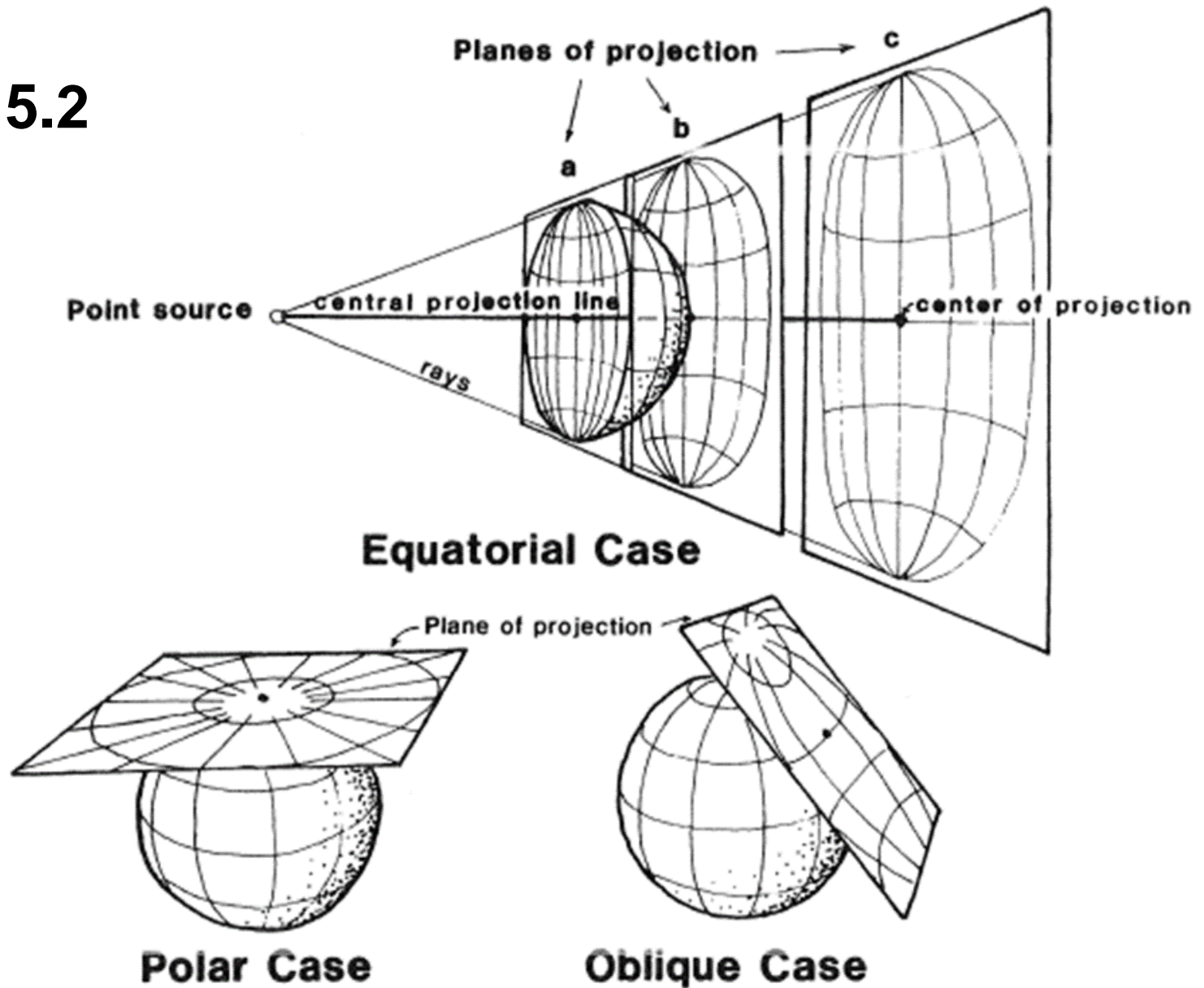

Concept of Stereographic Projection cont'd

- A ***stereographic projection*** is a **special kind of azimuthal projection** that was developed and refined by **crystallographers**.
- The **special characteristic of a stereographic projection** is that
- The **point source** used in its construction **lies on the surface of the sphere**.

Concept of Stereographic Projection cont'd

- **In geology** the projection plane used to construct a stereographic projection is positioned to **pass through the center of the sphere.**

Concept of Stereographic Projection cont'd

- **To visualize the construction of a stereographic projection:**
 - Imagine that a dot has been marked on the lower half of a **glass sphere**;
 - The **dot** is a **spherical projection** of a point in space.

Concept of Stereographic Projection cont'd

- A **stereographic projection** of the dot is constructed by drawing a projection line from a ***zenith point***, placed at the top of the sphere, to the **dot**.
- This **projection line** must **pass through** the **equatorial plane** of the sphere.

Concept of Stereographic Projection cont'd

- The **intersection between the projection line** and the **equatorial projection plane** is the **stereographic projection** of the **dot (Fig. 5-3)**.

Concept of Stereographic Projection cont'd

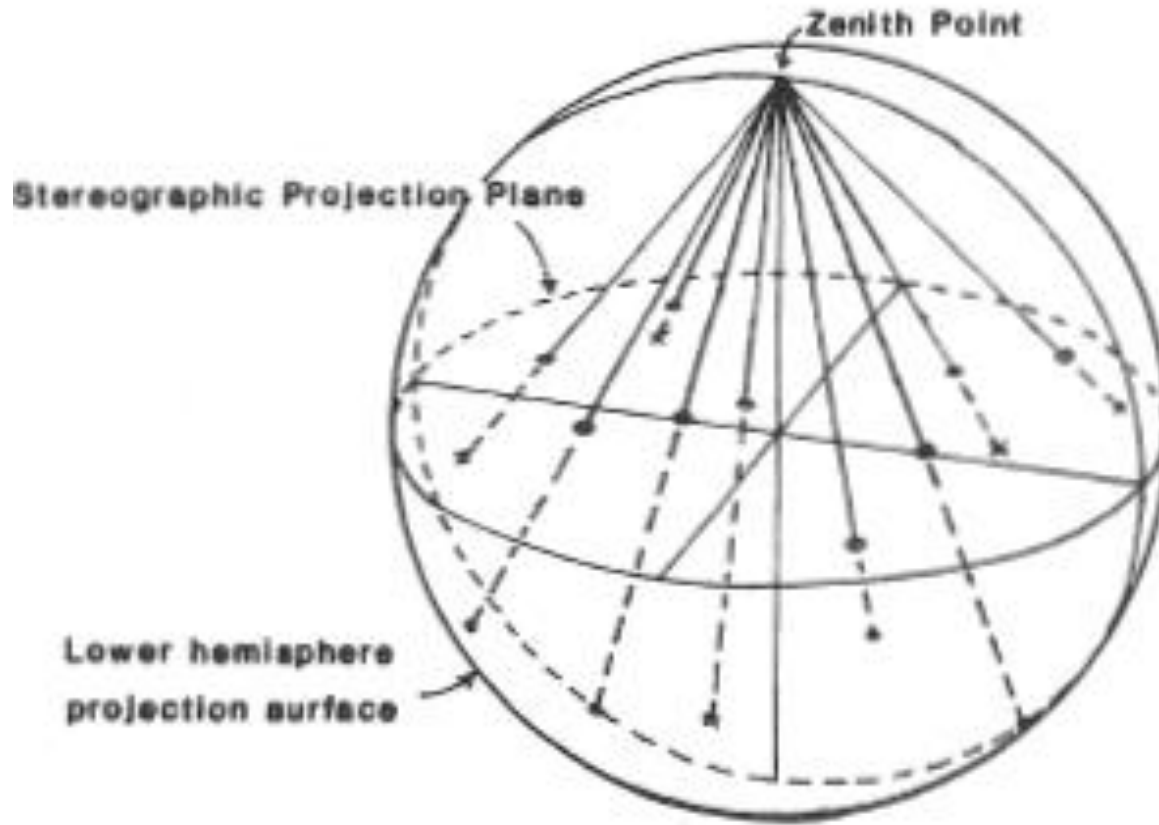

Fig. 5-3. The basis of a lower hemisphere stereographic projection on an equatorial plane:

- The projection of a point on the lower hemisphere lies along a line drawn from the **point to the zenith**.

Concept of Stereographic Projection cont'd

- In structural geology we always project points from the **lower half of the sphere**.
- Thus, in figure captions of structural geology papers you will usually see the words "**lower hemisphere projection**."

Concept of Stereographic Projection cont'd

- The intersection of the **equatorial projection plane with the sphere** is called the ***primitive circle*** (often abbreviated simply as "***the primitive***").
- The **primitive** has the same radius as the original projection sphere, and

Concept of Stereographic Projection cont'd

- **All points** on the surface of the lower hemisphere **project to points inside the primitive on the projection plane** (Fig. 5-3).

Concept of Stereographic Projection cont'd

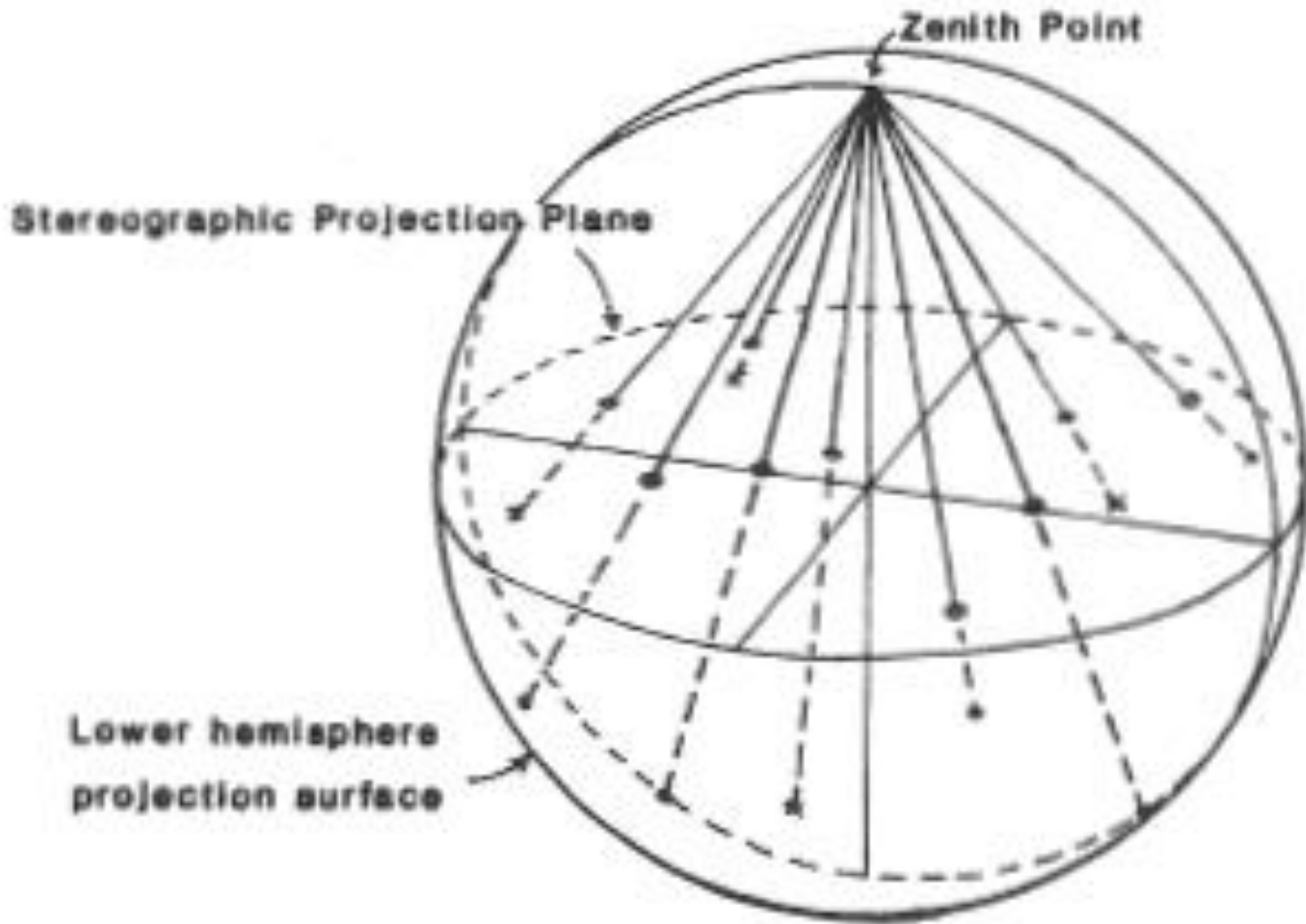

Fig. 5.3

Concept of stereographic projects:

Stereographic Projection of a PLANE

Stereographic Projection of a plane

- Imagine a dipping plane that intersects the ground surface;
- The plane can be a bed, a fault, a joint, or any other planar structure.
- The trace of the plane on the ground surface is a straight line (**Fig. 5-4a**).

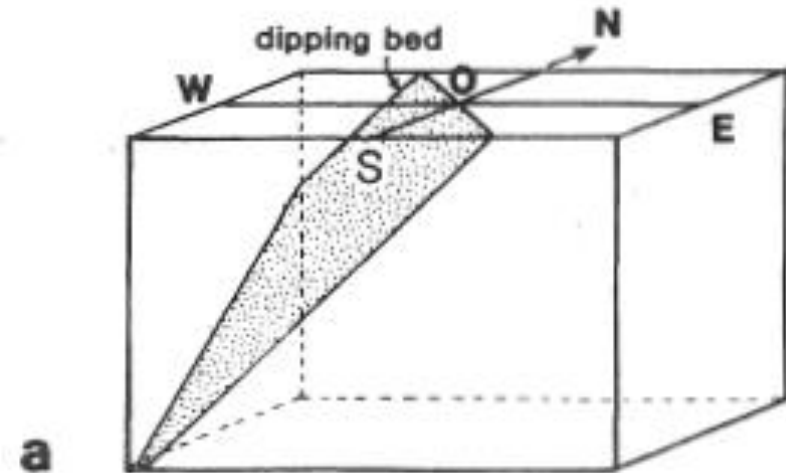

Fig.5-4 a:

- Block diagram of a plane oriented 300° , 50°SW ;

Stereographic Projection of a plane cont'd

- Create a projection sphere of radius r that is centered at a point O on the outcrop trace of the inclined plane.
- The dipping plane (and its extension into the sky) intersects the sphere as a circle, whose radius is the same as that of the sphere (Fig. 5-4b).

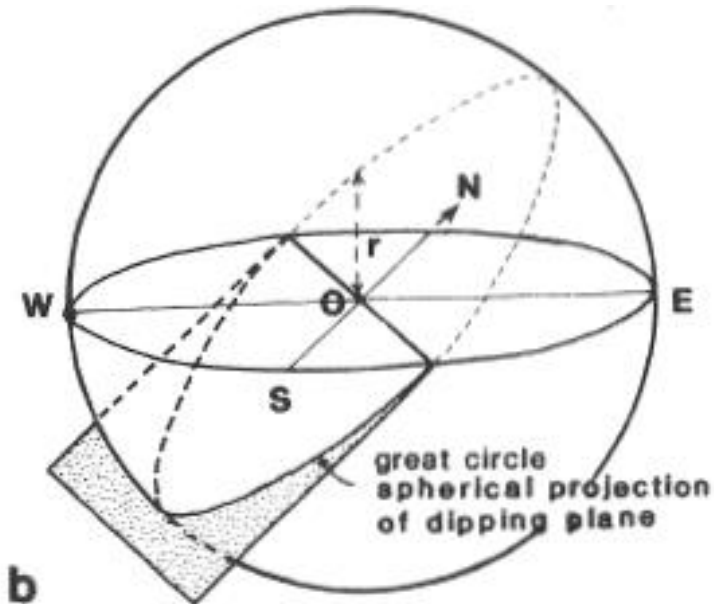

Fig 5-4b: projection sphere (radius r) set up on an outcrop trace that intersects the plane in a great circle (adapted from Hobbs et al., 1976);

Stereographic Projection of a plane cont'd

- This circle is the **spherical projection** of the dipping plane and is called a ***great circle***.
- A plane with a different attitude will intersect the sphere along a **different great circle**.
- In other words, there is a **unique great circle** for each different orientation of a plane.

Stereographic Projection of a plane

- To construct the stereographic projection of the plane:
 - ✓ Join each point on the portion of the great circle projection that lies on the lower half of the projection sphere to the **zenith (Z)** of the projection sphere (**Fig. 5-4c**).

Stereographic Projection of a plane cont'd

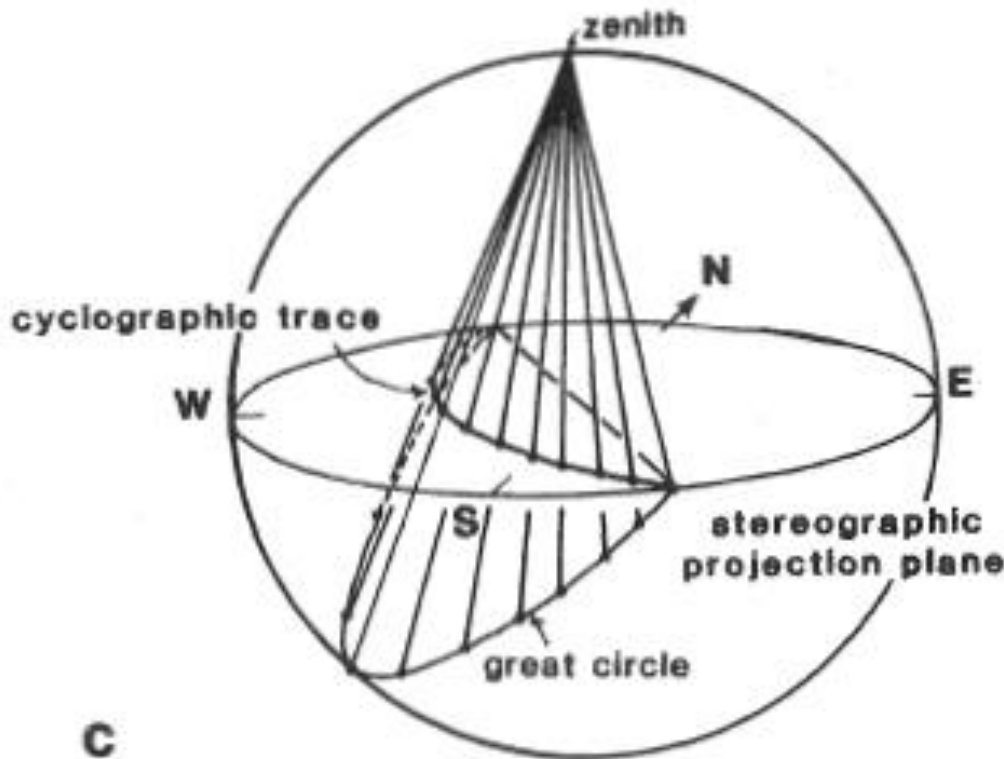

Fig. 5.4c:

- lines from the zenith to the lower half of the great circle intersect the equatorial projection plane in a **circular arc** (the **cyclographic trace**) (adapted from Hobbs et al., 1976);

Stereographic Projection of a plane

- ✓ These straight lines generate part of a **circular cone** that intersects the equatorial projection plane as part of a **circular arc**.
- ✓ The arc is the **stereographic projection** of the dipping plane and is called a **cyclographic trace** of the plane (**Fig. 5-4d**).

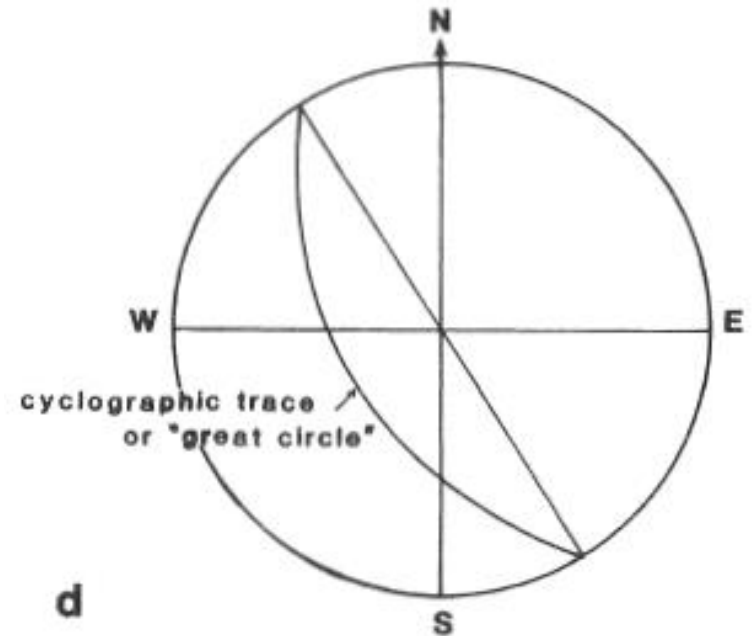

Fig. 5-4d: The completed stereogram of the dipping plane.

Stereographic Projection of a plane cont'd

- ✓ We will refer to the arc as a ***great circle*** because it corresponds to a great circle on the original spherical projection.

Stereographic Projection of a plane cont'd

Note that:

- A **horizontal plane** will project along the primitive circle (**i.e, the radius of curvature equals the radius of the projection sphere**), and
- A vertical plane will project as a straight line passing through the center of the primitive circle (**i.e., the radius of curvature is infinity**).

Stereographic Projection of a plane cont'd

- A plane of **intermediate dip** projects as a cyclographic trace with a radius of curvature **intermediate between that of the primitive and infinity;**
- The **radius of curvature** of a plane's cyclographic trace **increases as the dip angle increases (Fig.5-5a).**

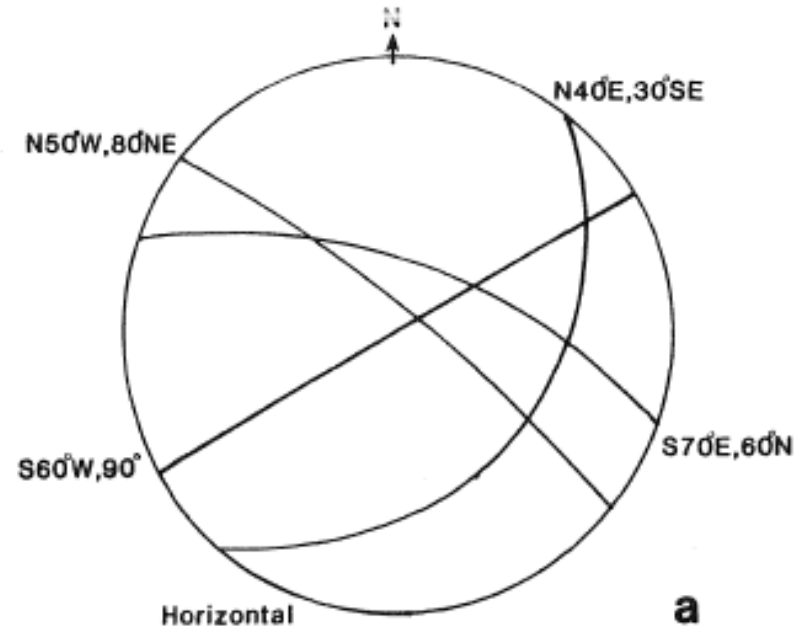

(Fig.5-5a).

Stereographic Projection of a plane cont'd

Also note that:

- As the strike of the plane changes, the two intersections between the cyclographic trace and the primitive rotate around the primitive.
- The two intersections are, however, always exactly 180° apart.

Stereographic Projection of a plane cont'd

- To help visualize stereographic projections of planes:

- Imagine a hemispherical cereal bowl (Fig. 5-5b).
- Hold your hand so that it (YOUR HAND) passes through the center of the hemisphere and intersects the inside surface of the bowl.



b

Stereographic Projection of a plane cont'd

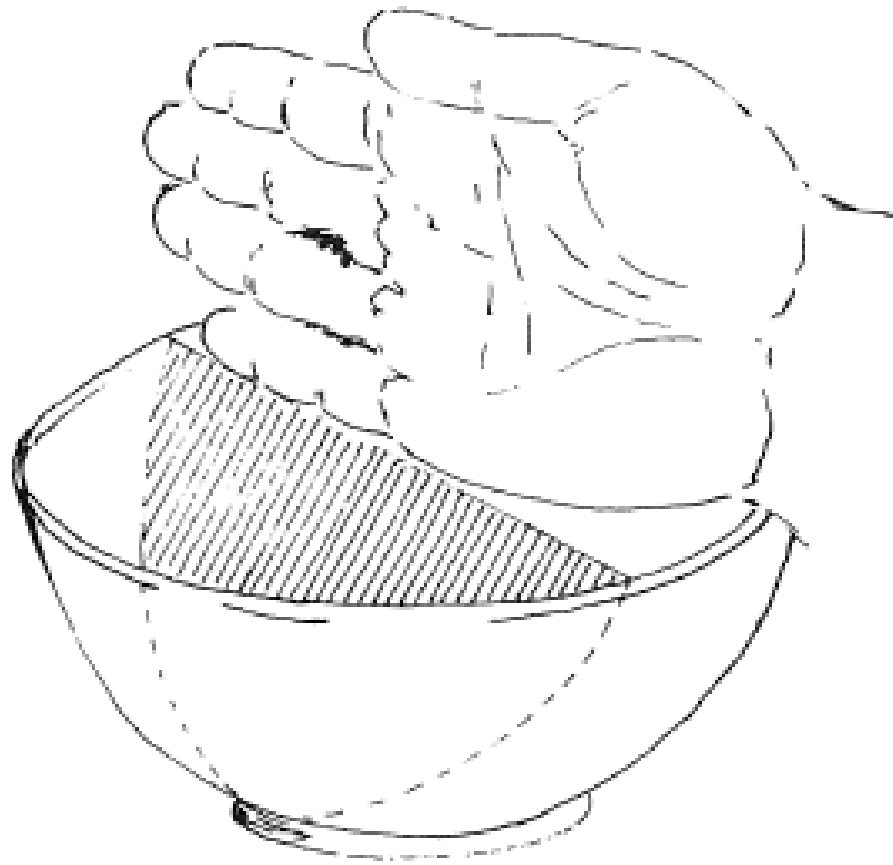

b

Stereographic Projection of a plane cont'd

- Then, look straight down on the bowl so that you simulate projecting the bowl onto an **equatorial plane**.
- From this viewpoint the **intersection of your hand with the bowl corresponds to the stereographic projection of your hand**.

Stereographic Projection of a plane cont'd

- As you make your hand dip more steeply,
- The cyclographic trace of your hand approaches the center of the bowl and starts to look **like a straight line**.
- As you make your hand dip more shallowly, the cyclographic trace of your hand approaches the rim of the bowl and starts to look **like a circle**.

Concept of stereographic projection:

Stereographic Projection of a LINE

Stereographic Projection of a line

- The **orientation of any linear geologic structure** (such as a **mineral lineation**, **fold hinge**, or the **axis of a drill hole**)
- Can be **represented on a stereographic projection** in a manner **similar** to that described for planes.

Stereographic Projection of a line

- First, you must visualize a spherical projection of the structure.
- A linear structure can be represented as a line that passes through the center of the projection sphere and
- Intersects the surface of the lower hemisphere at a point P (Fig. 5-6a), which is the spherical projection of the line.

Stereographic Projection of a line

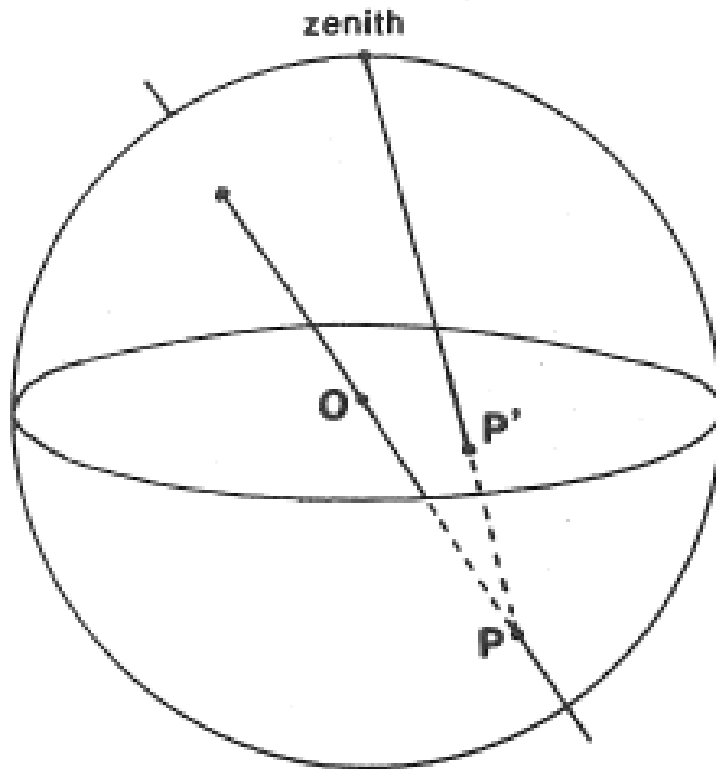

a

Fig. 5.6 a: Stereographic representation of a line:

- A line **OP** through the center of the sphere pierces the lower hemisphere at a point **P** that is the spherical projection of the line.
- A line from **P** to the zenith intersects the **equatorial projection plane** at **P'**, which is the **stereographic projection of the line**;

Stereographic Projection of a line

- A straight line joining **P** to the **zenith** of the projection sphere intersects the projection plane at point **P'**, which is the ***stereographic projection*** of the line.
- A **vertical line** will project as a point at the **center of the primitive circle**, and a **horizontal line** will project as a **point on the primitive circle** itself.

Stereographic Projection of a line

- Points corresponding to lines of **intermediate plunge** lie somewhere between the **center** and the **primitive**, with **steeper lines** lying **closer to the center** (Fig. 5-6b).

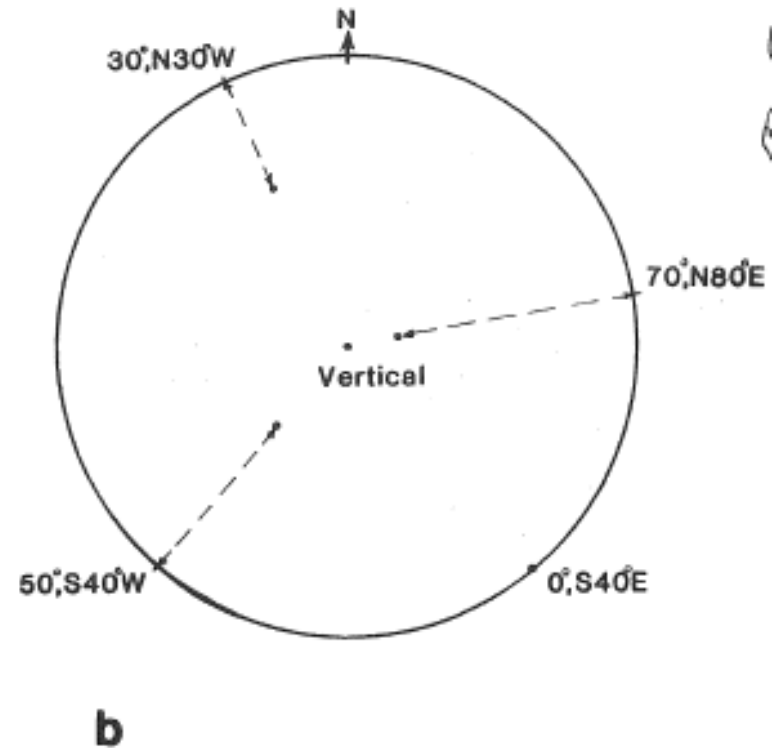

Stereographic Projection of a line

- If you fix the plunge of a line, but vary its trend through **360°**,
- The succession of points representing the stereographic projection of the line will describe a circle that is **concentric with the primitive.**
- Again the cereal bow analogue can help visualise the stereographic projection of the line.

Stereographic Projection of a line

- Use your **index finger to simulate a line**, and
- make sure that your finger passes through the center of the imaginary sphere of which the bowl is the lower half (**Fig. 5-6c**).

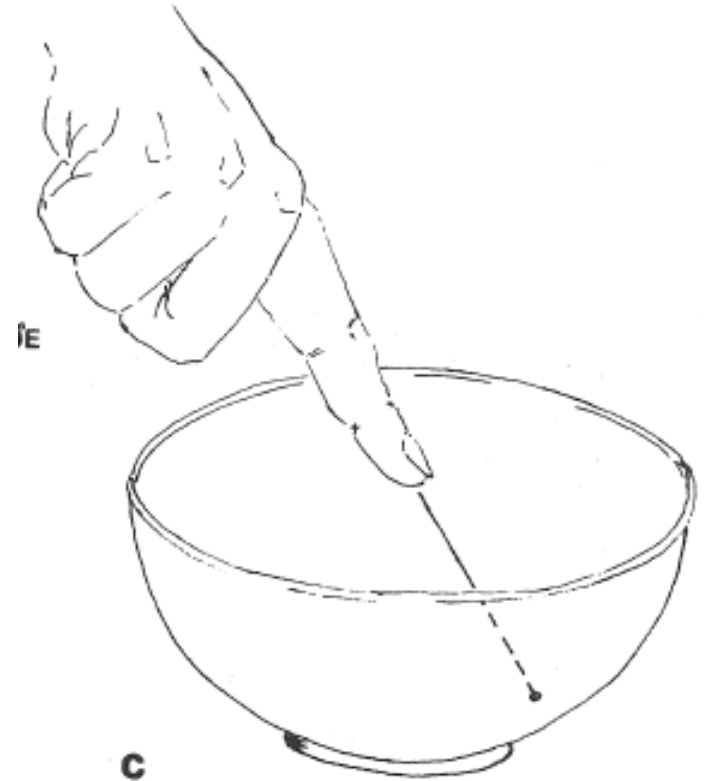

Fig. 5-6c: The cereal bowl analogy for lines. Use your index finger to simulate lines of different orientations.

Stereographic Projection of a line

- Clearly, the **intersection of your finger with the surface of the bowl is a point.**
- As you move your finger to different orientations, note how the position of the point moves.
- If your finger is vertical, it touches the center of the base of the bowl, and
- If it is horizontal, it touches the rim of the bowl

Concept of stereographic projects:

The STEREONET

The Stereonet

- **Visualization of the Stereonet Grid:**

- ✓ Stereographic projections would be of **limited use** if you first had to construct a **spherical projection** every time you wanted to create a **stereographic projection** of a line or plane.
- ✓ **Fortunately**, if a coordinate grid is projected onto the **plane of the stereographic projection**, **the projections of lines and planes can be plotted directly.**

The Stereonet

■ Visualization of the Stereonet

Grid cont'd:

- ✓ A coordinate grid (Fig. 5-8a) that is constructed using a stereographic projection is called a **stereonet**.
- ✓ The **stereonet** is also called an **Equal-Angle Net** or a **Wulff Net**, after the crystallographer who popularized its use.

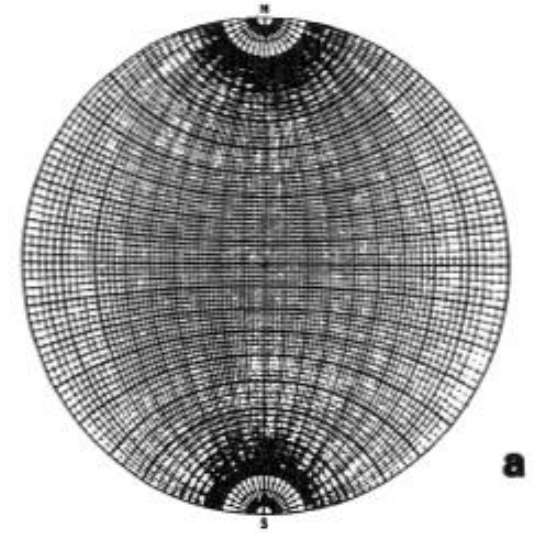

The Stereonet

Equal-Angle Net or Equal Angle Projection:

The projection preserves angular relationships.

*This means that the angle between the tangents to two intersecting great-circle traces at their point of intersection is the same as the angle between the two real planes that the great-circle traces represent (**Fig. 8-1a**).*

The Stereonet

■ Visualization of the Stereonet Grid cont'd:

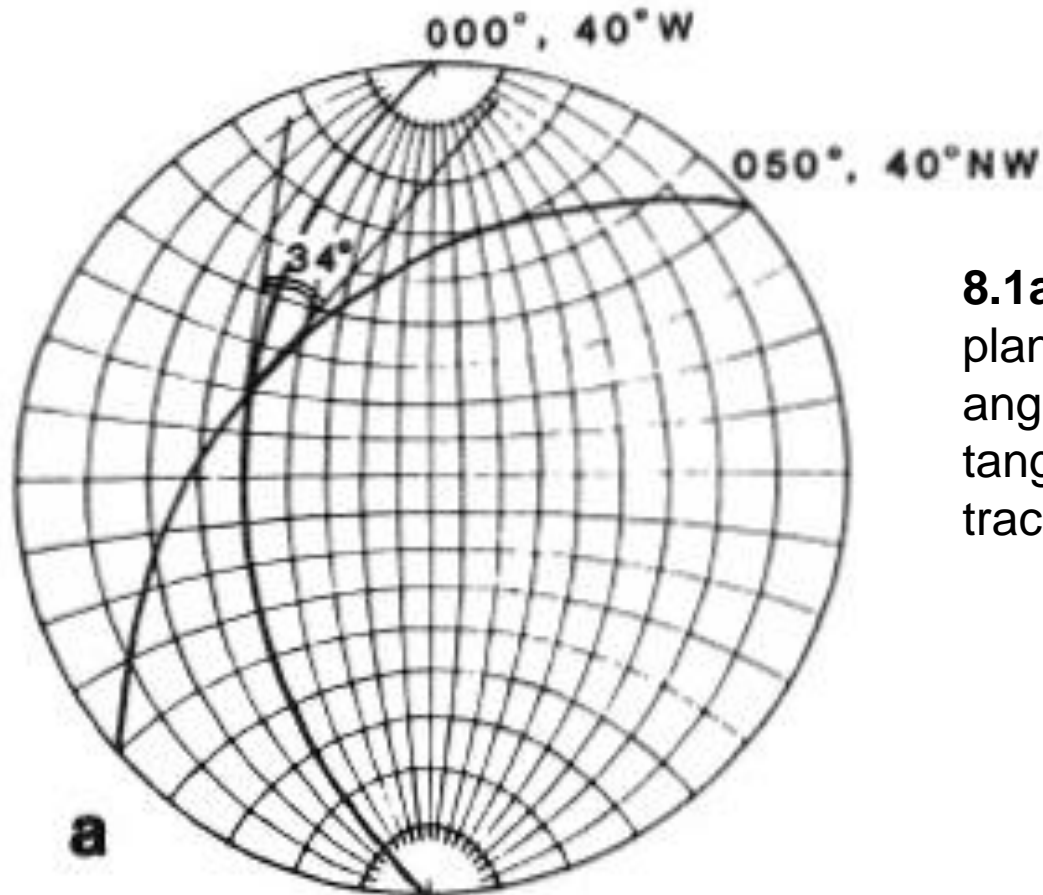

8.1a: The angle between two planes is the same as the angle between the tangents to the great-circle traces of the two planes

The Stereonet

- **Visualization of the Stereonet Grid cont'd:**
 - ✓ The **representation** of a **point**, **line**, or **plane** on a stereonet is called a ***stereogram***.

The Stereonet

- A **stereonet** is constructed by drawing the **great-circle cyclographic traces** of a set of planes that **all intersect along a line (N-S)** that runs between the poles of the primitive and passes through the center of the projection sphere (**Fig. 5-8b**).

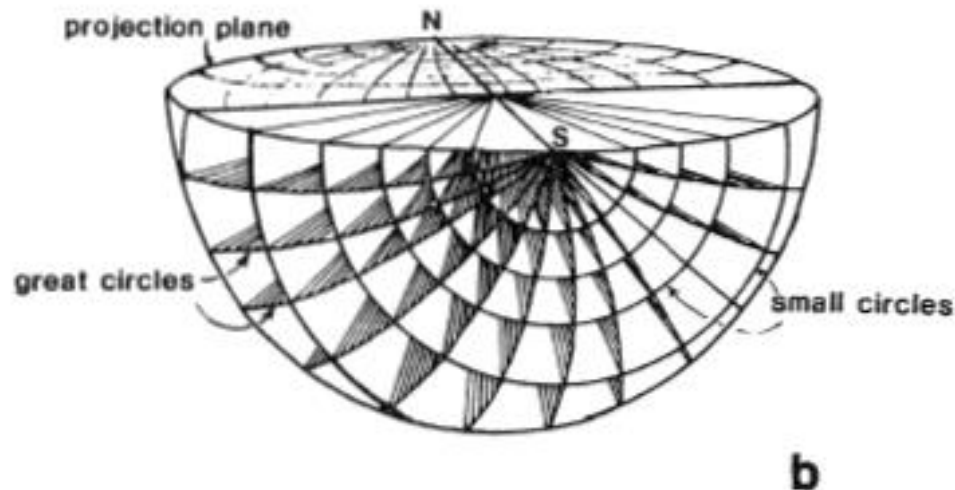

The Stereonet

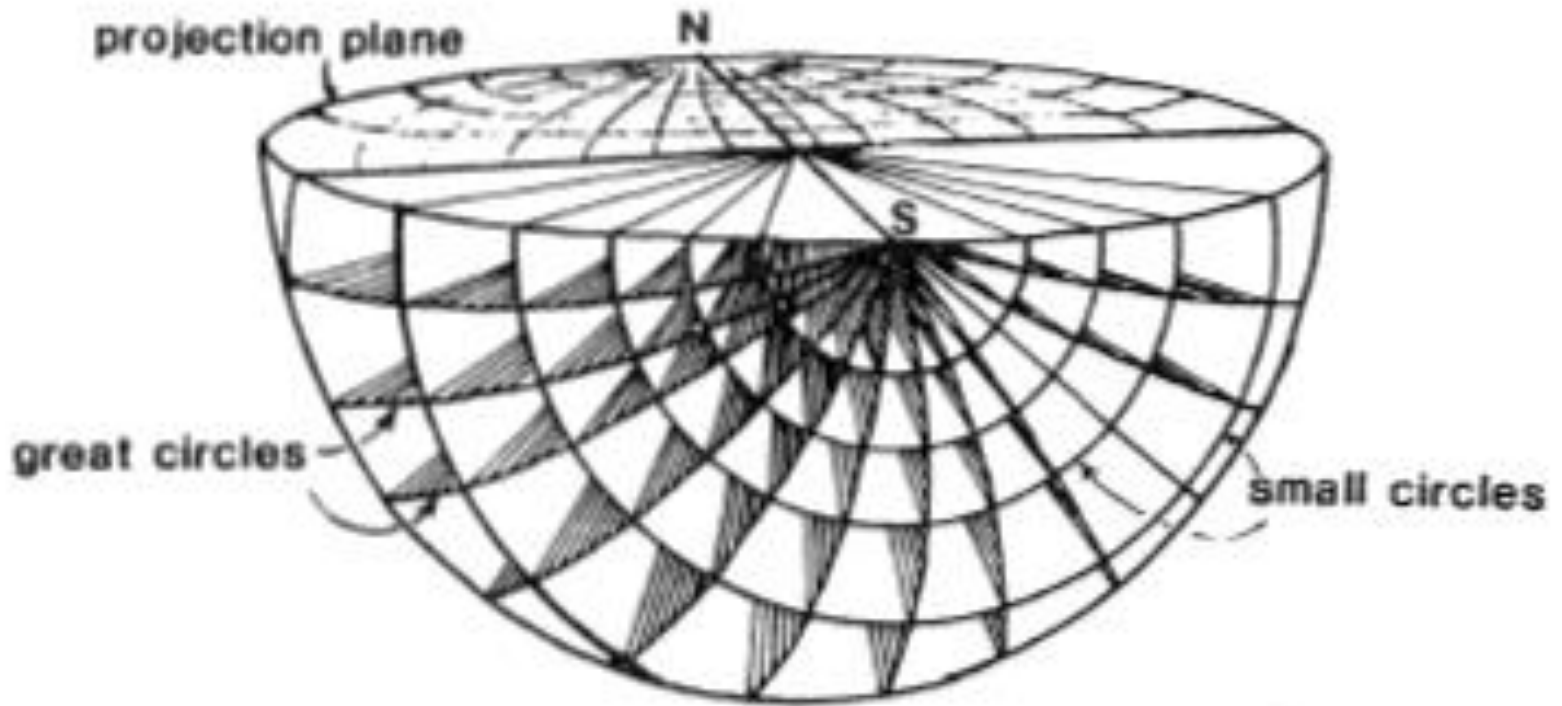

The Stereonet

- The angle between each plane and its neighbor is **2°**.
- Thus, the cyclographic traces define a **longitudinal grid** with a **2° interval between adjacent grid lines**.
- Every **fifth grid line** is **darker**, so that it stands out and makes the grid **easier to read**.

The Stereonet

- Superimposed on the **longitudinal** grid is a **latitudinal** grid, composed of the stereographic projections of **small circles**.
- These small circles are constructed from the spherical projections of a series of **coaxial right circular cones** [i.e. with axis perpendicular to plane of base] with progressively decreasing ratios between the basal radius and the altitude.
- The axis of these cones is the line [N-S] that runs between the north and south poles of the primitive and passes through the center of the projection (**Fig. 5-8b**)

The Stereonet

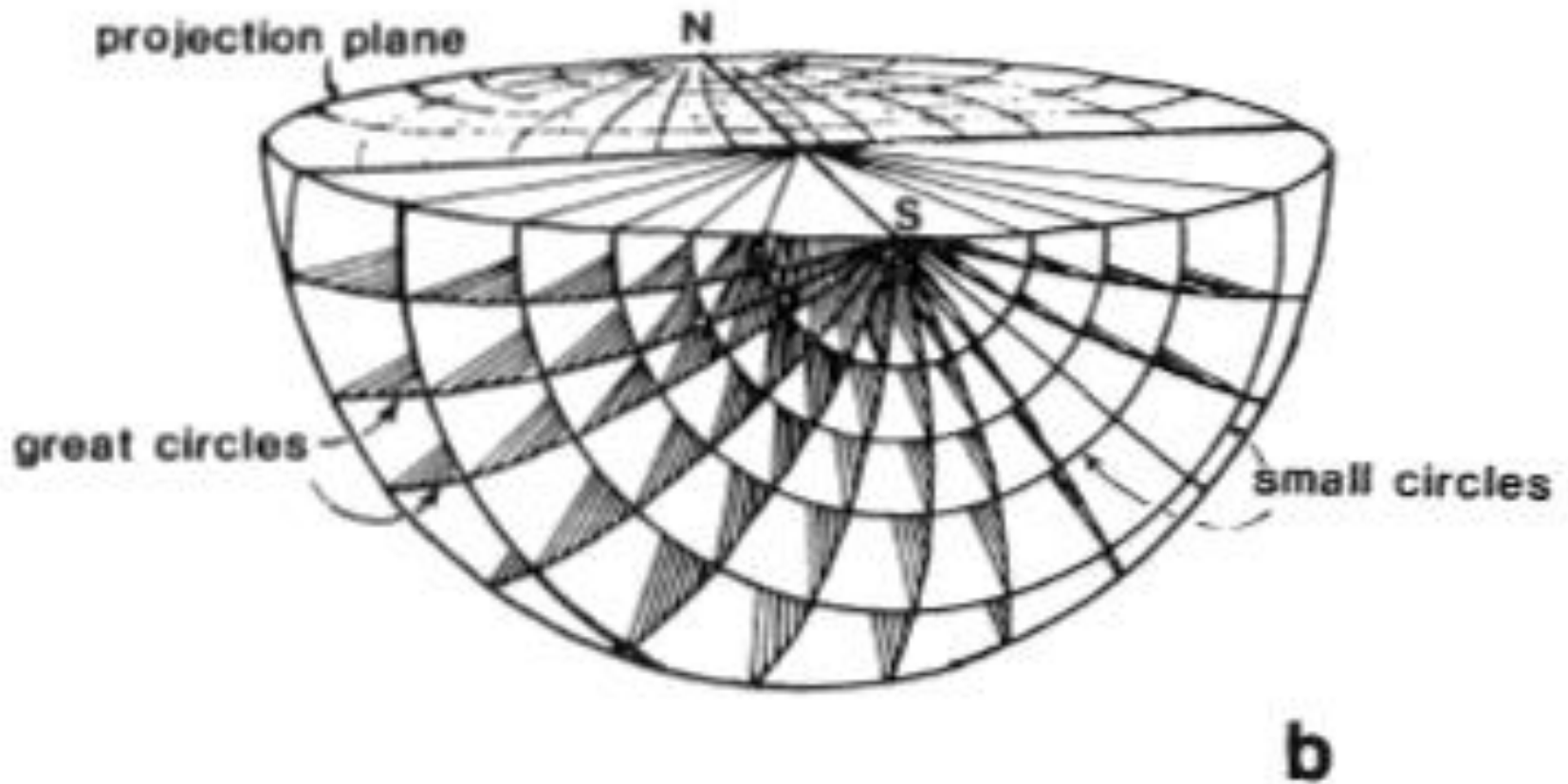

Equal Area

North

10°
20°
30°
40° strikes
50°
60°
70°
80°

a great circle

dip

West

10°
20°
30°
40°
50°
60°
70°
80°
90°

East

a small circle

South

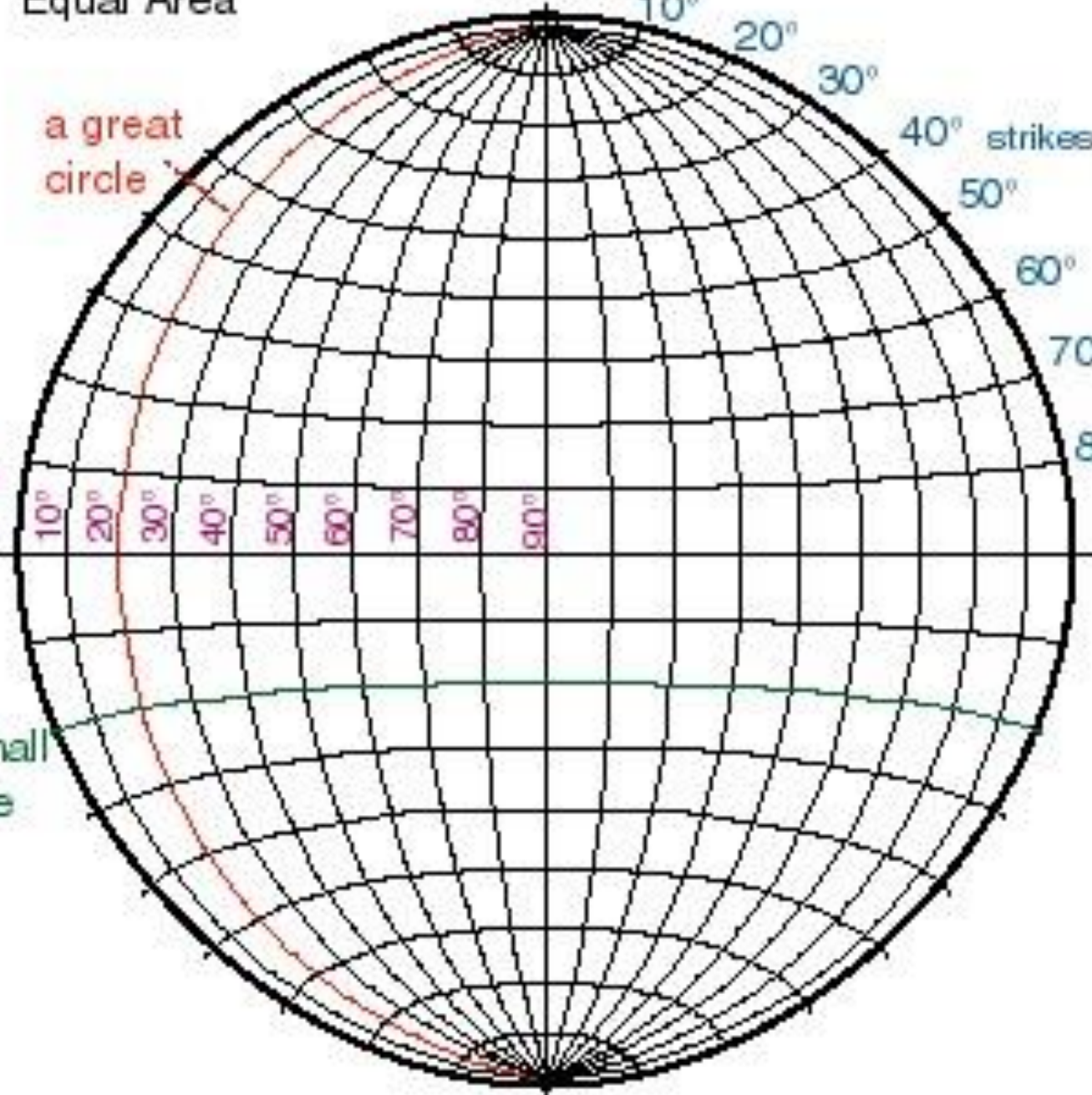

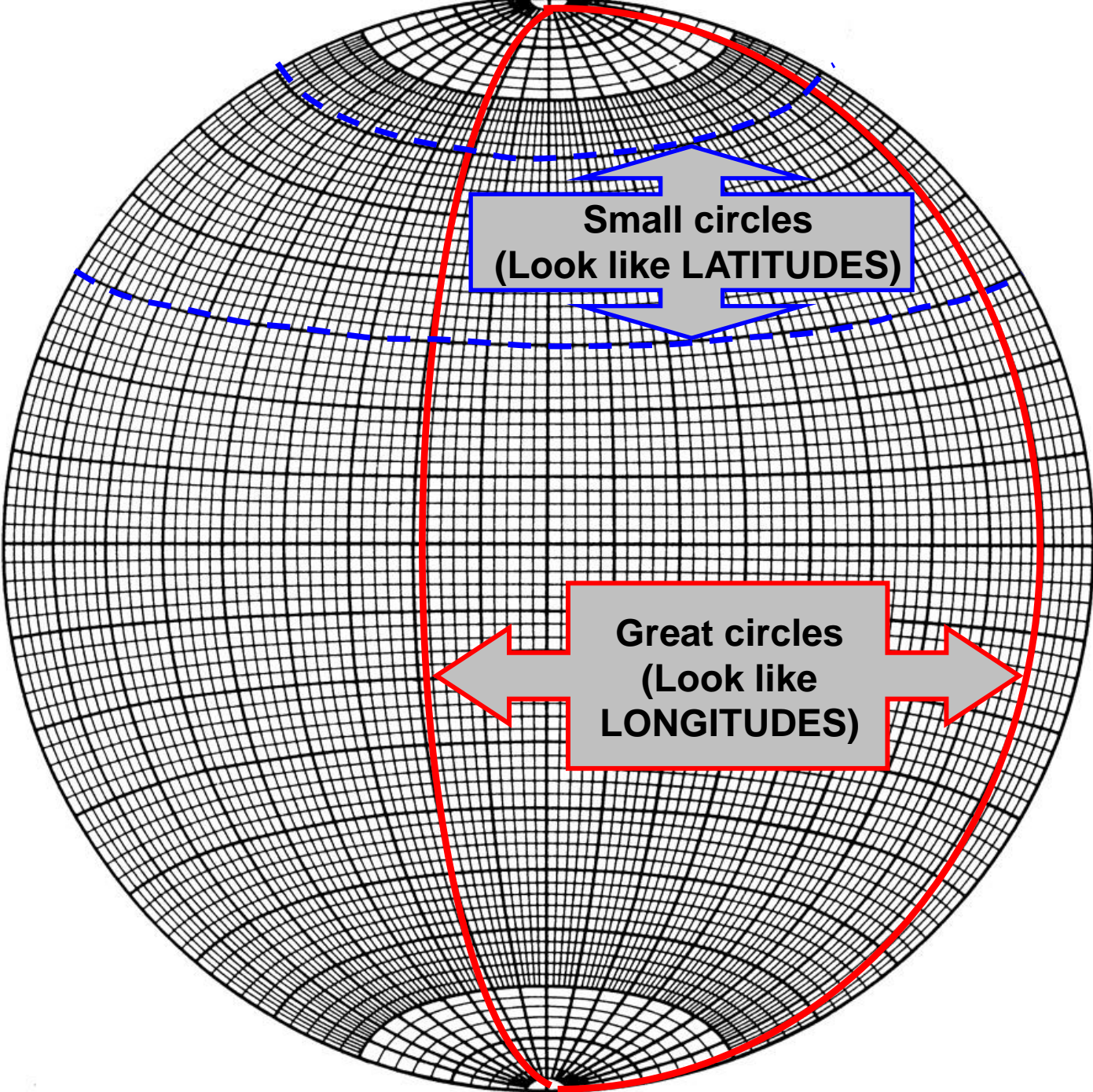

**Small circles
(Look like LATITUDES)**

**Great circles
(Look like
LONGITUDES)**

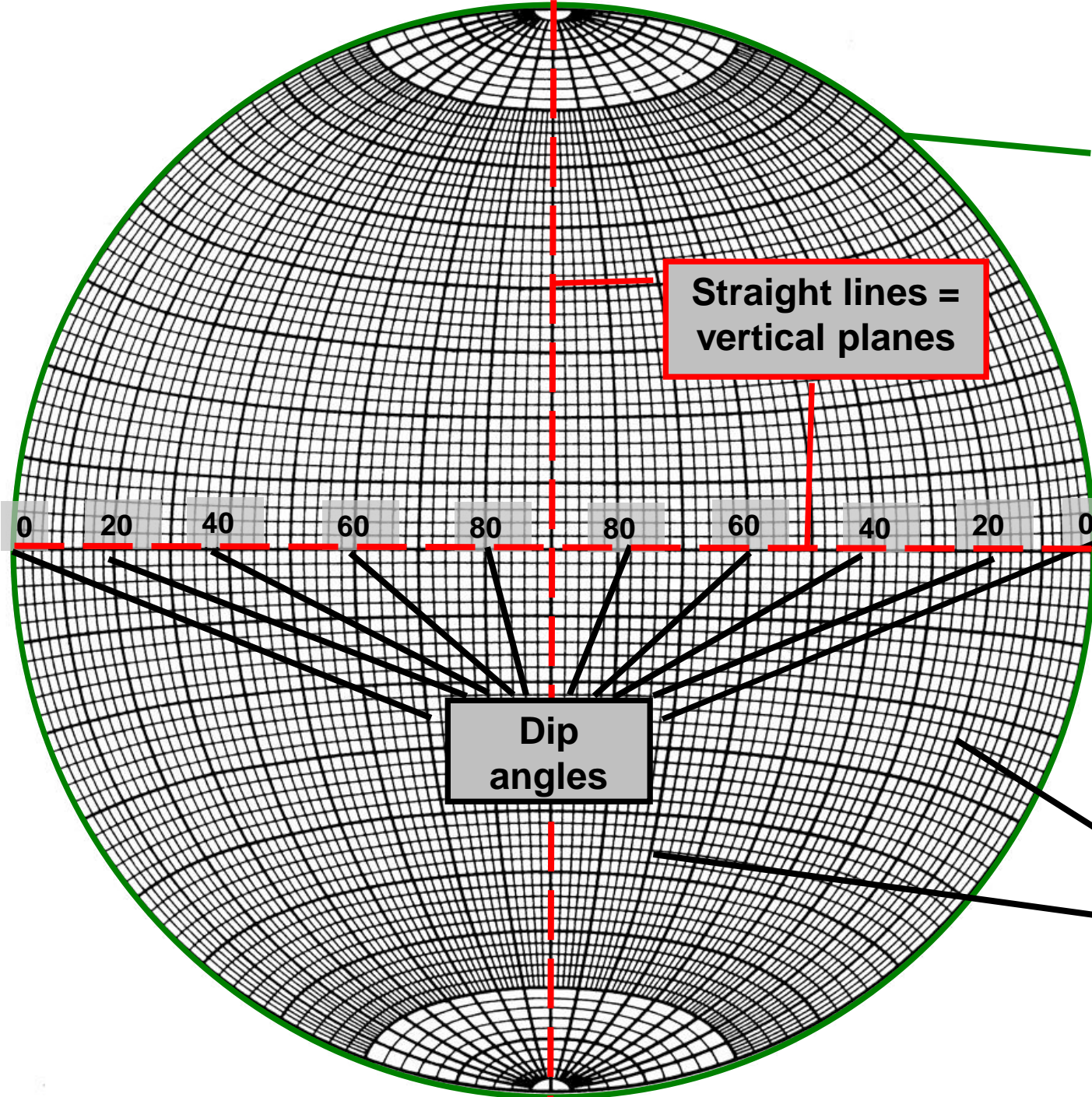

**Straight lines =
vertical planes**

**Equatorial
circle =
Primitive circle
horizontal
plane**

0 20 40 60 80 80 60 40 20 0

**Dip
angles**

**Great circles
= inclined
planes**

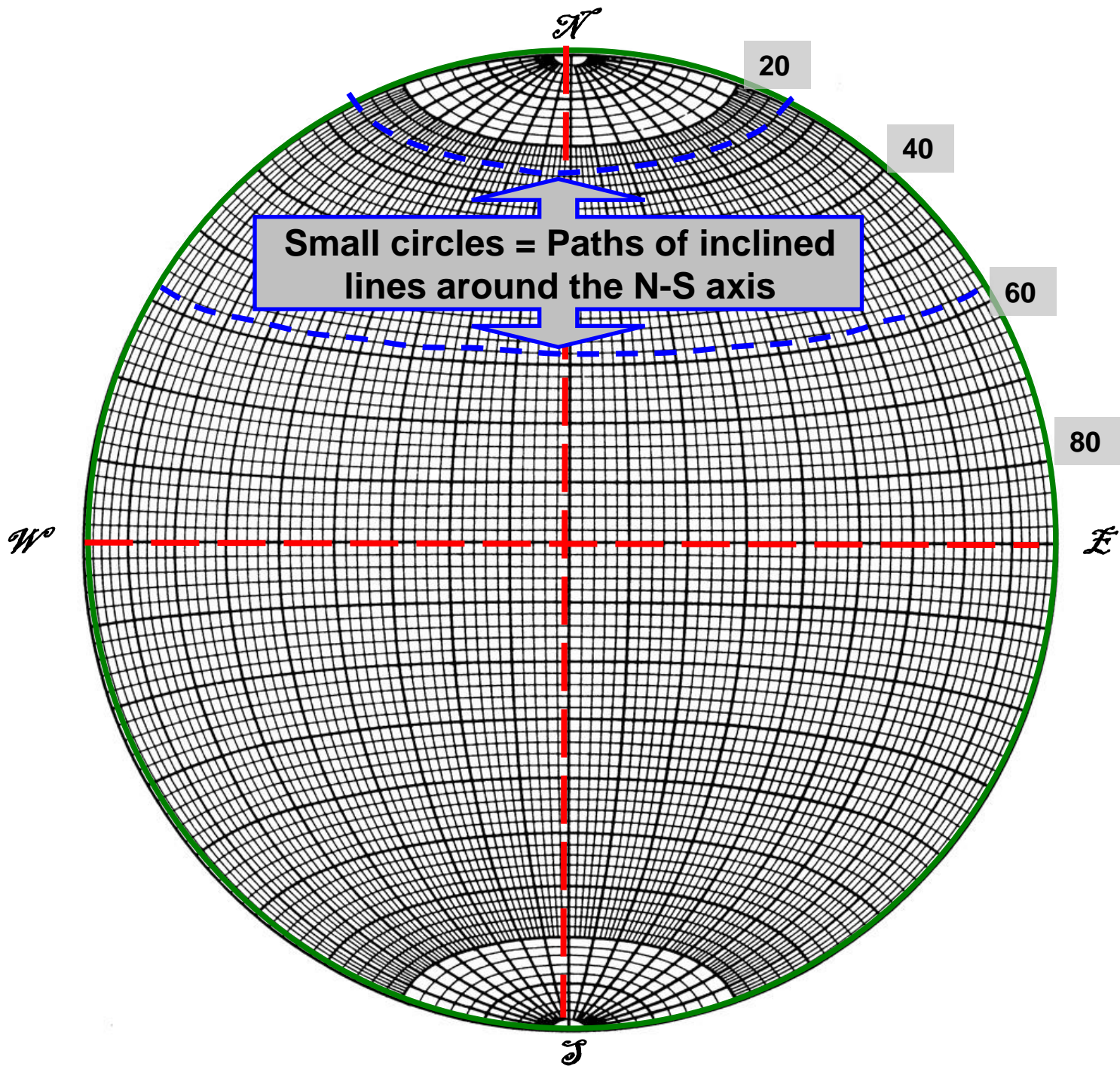

Right-hand Rule

We will use the right-hand rule convention for all structural measurements

- right-hand thumb points in direction of strike
- fingers point in direction of dip

Bedding plane striking N-S and dipping eastward at 45

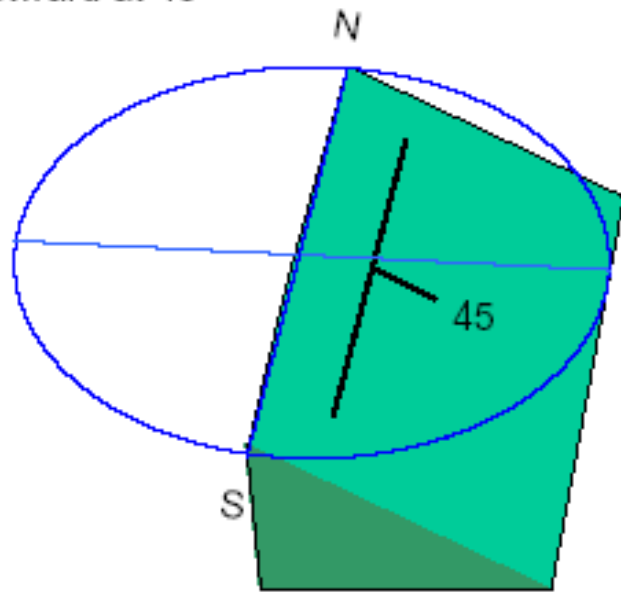

Strike direction

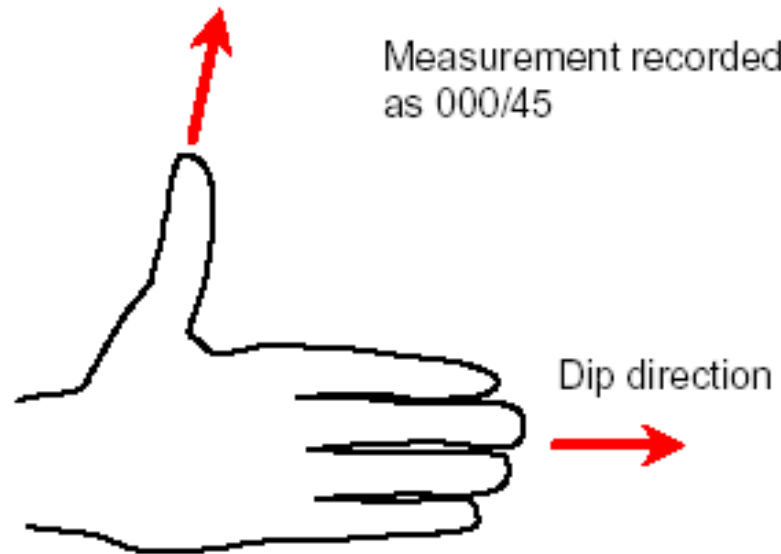

Sterionet projection of 3-D structural data

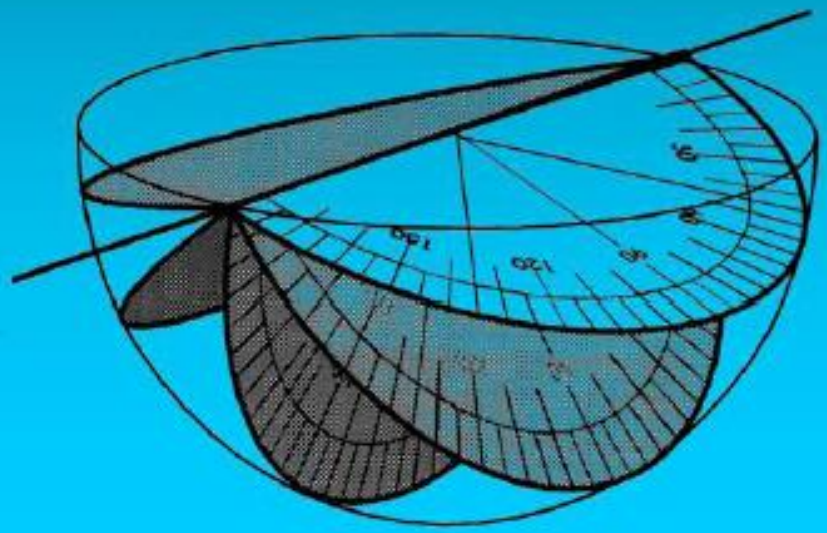
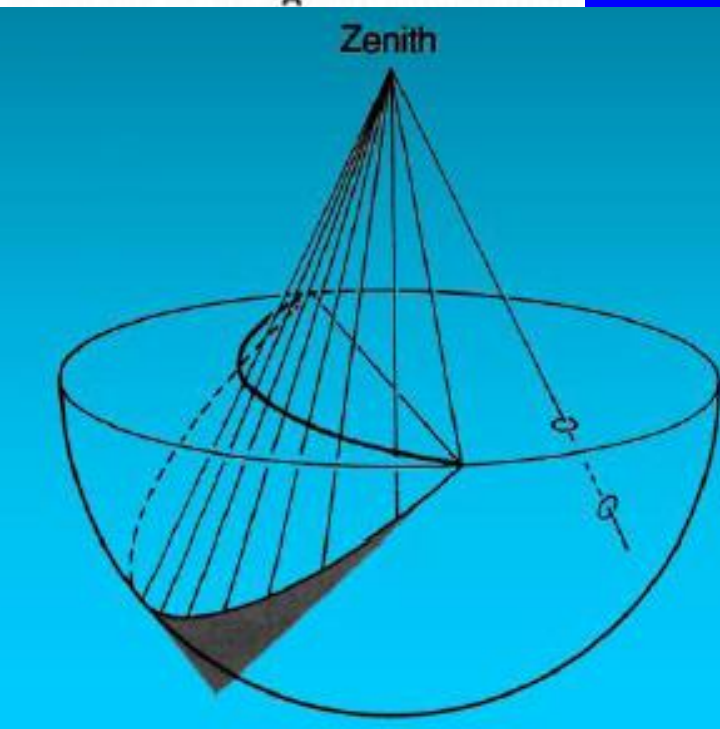
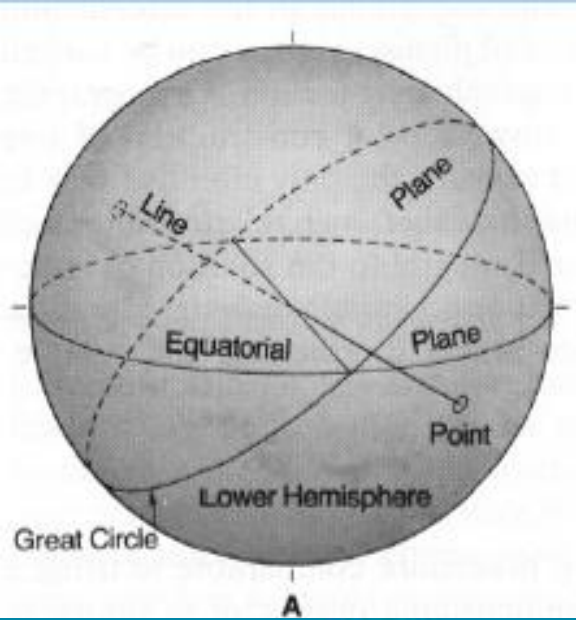

Lower hemisphere of a sphere projected onto a flat surface

- A type of '3-dimensional protractor'
- Allows analysis of structural data in 3-dimensions
- Plot data on tracing paper overlaid on net

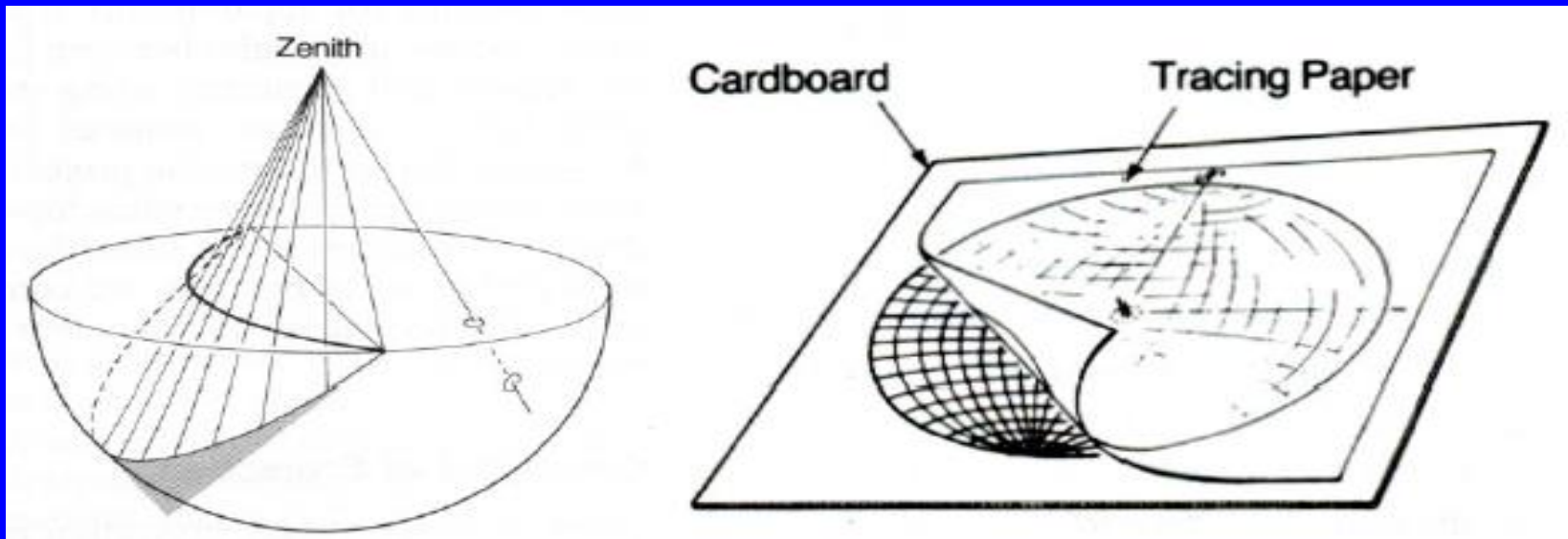

Two types of stereonetets used in Geology:

- 1. Schmidt Net**
- 2. Wulff Net**

Schmidt (Equal Area) Net

Each 2 degree polygon has an equal area

- used in structural geology because it preserves areal proportions (important for analysis of distributions)

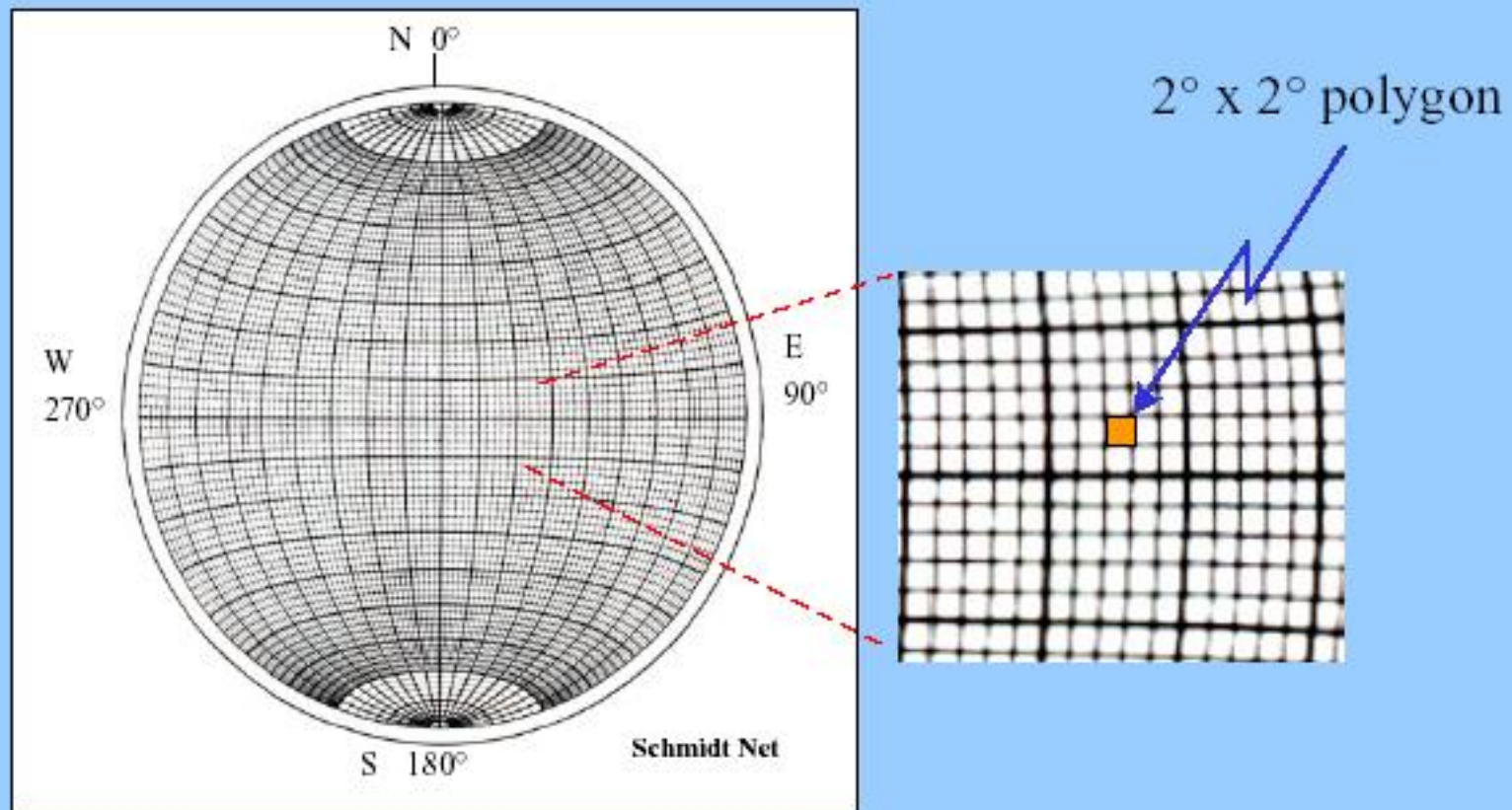

Wulff (Equal Angle) Net

Great and small circles are real circular arcs

- preserves angular proportions but not area
- used in crystallography, not much in structural

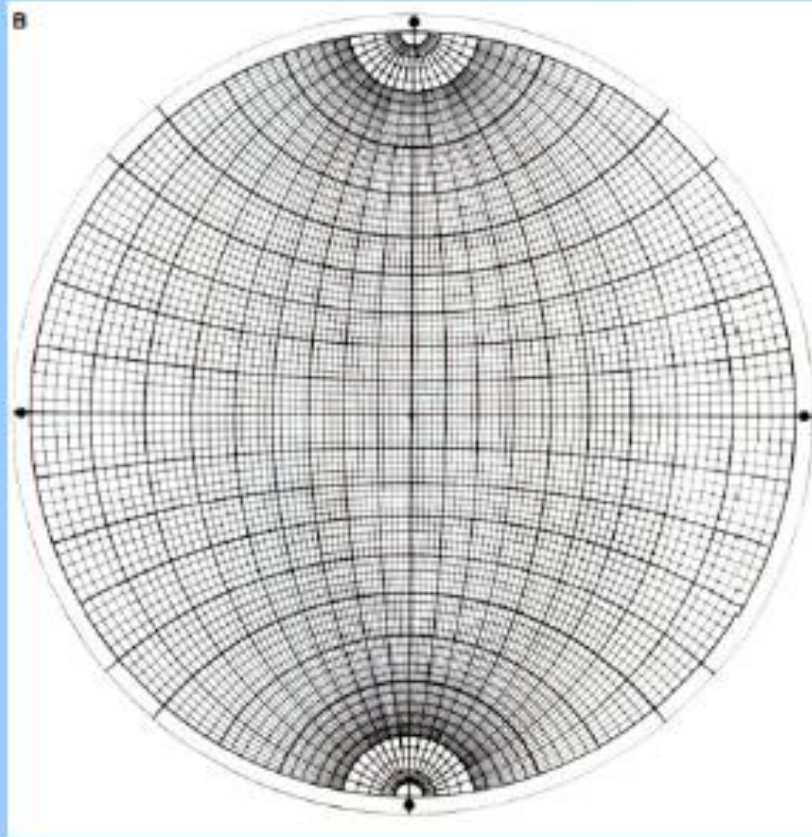

Plotting Lines - Trend and Plunge

Line projected onto lower hemisphere of net will appear as a single point on net

- e.g line plunging at 50° in the direction 130° (50/130)

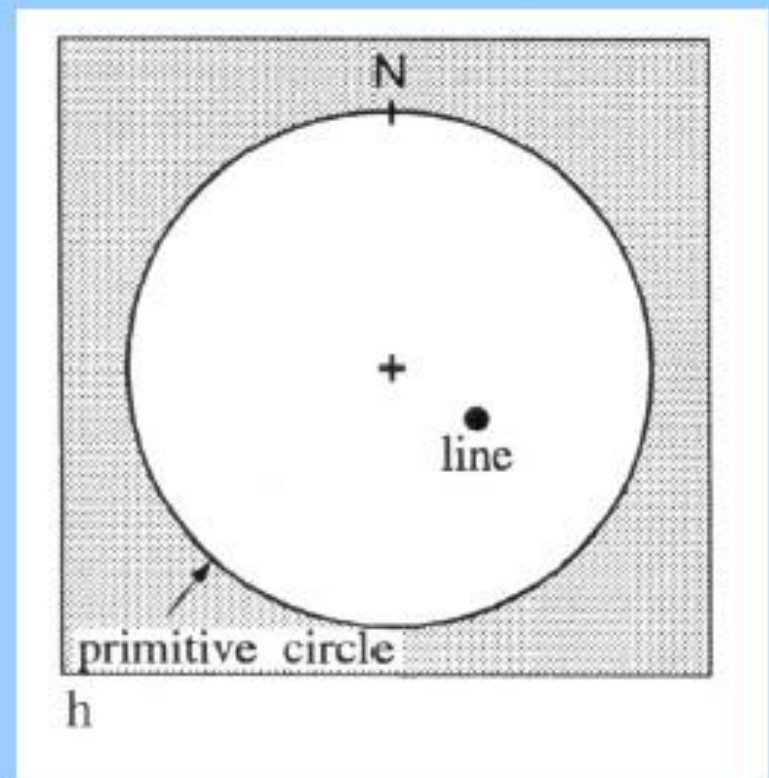
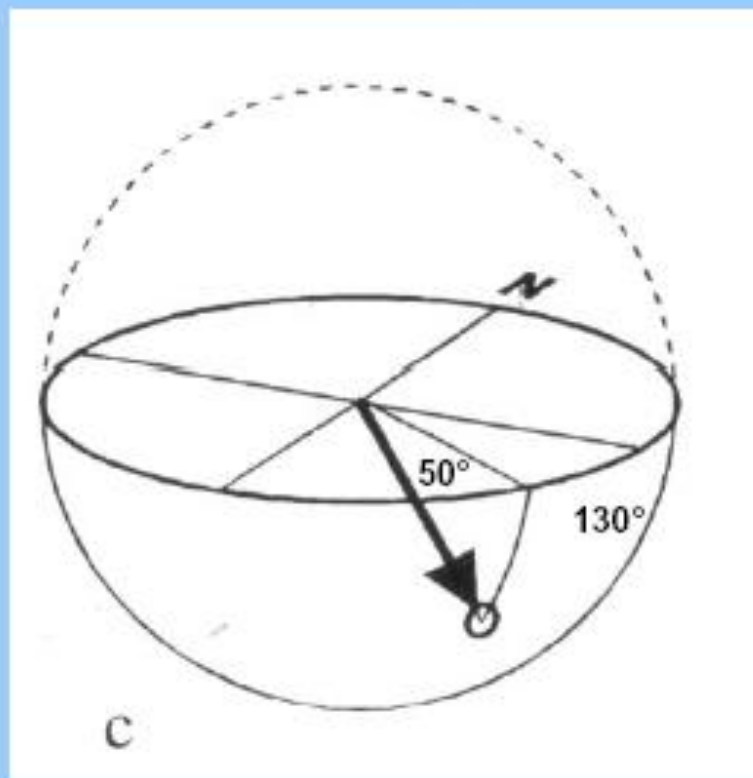

LINE

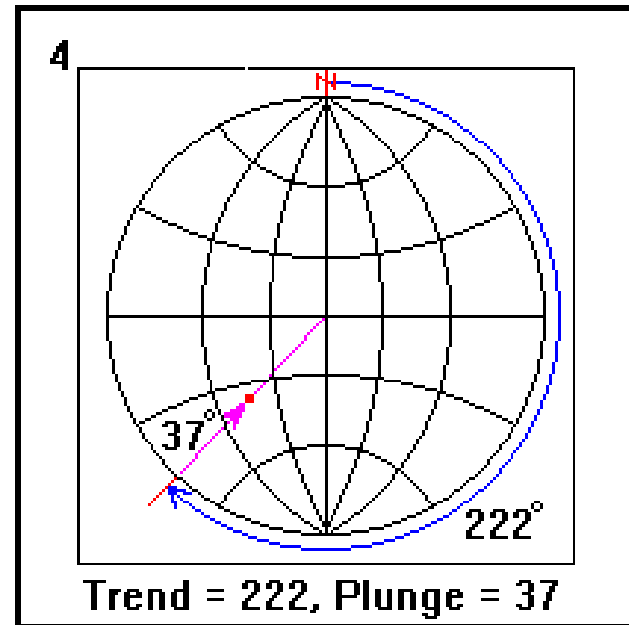
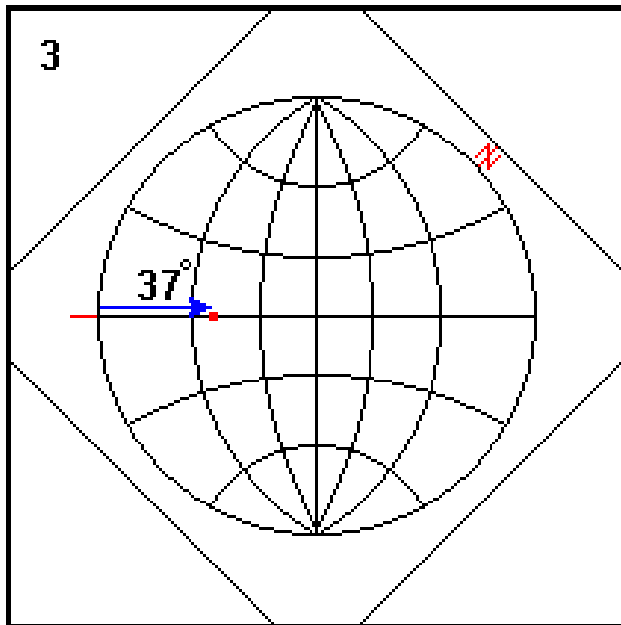
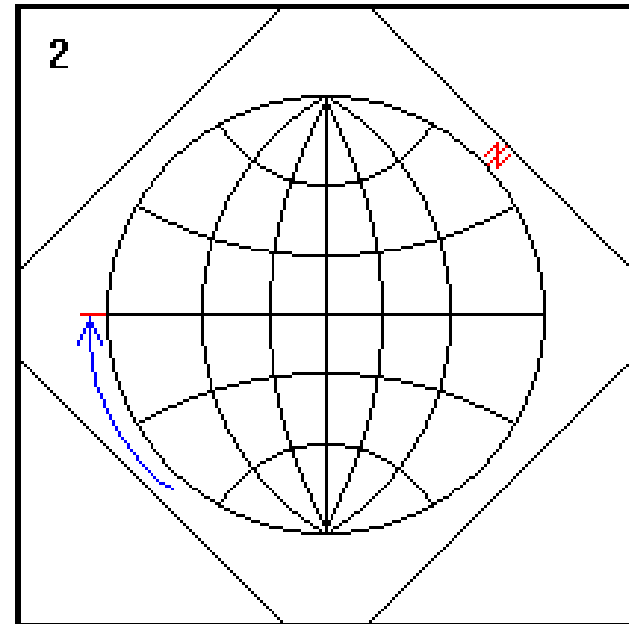
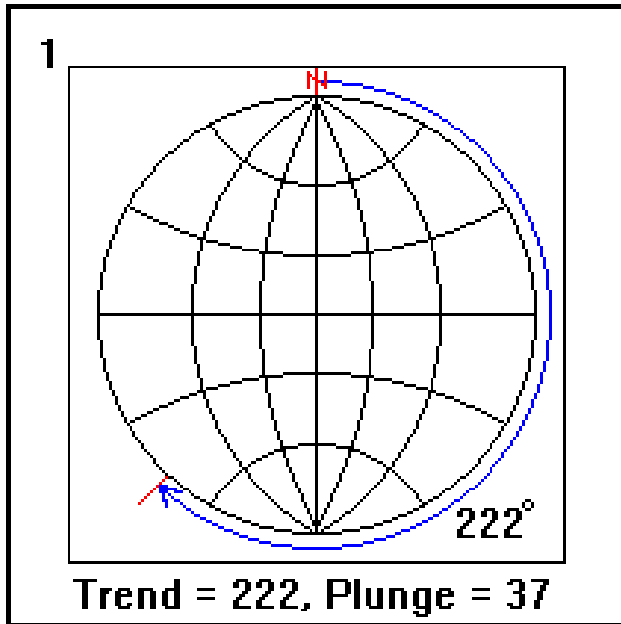

Plotting Planes

The intersection of a *plane* with the lower hemisphere of a sphere is a great circle

- e.g. bedding plane striking 030° and dipping 60° SE

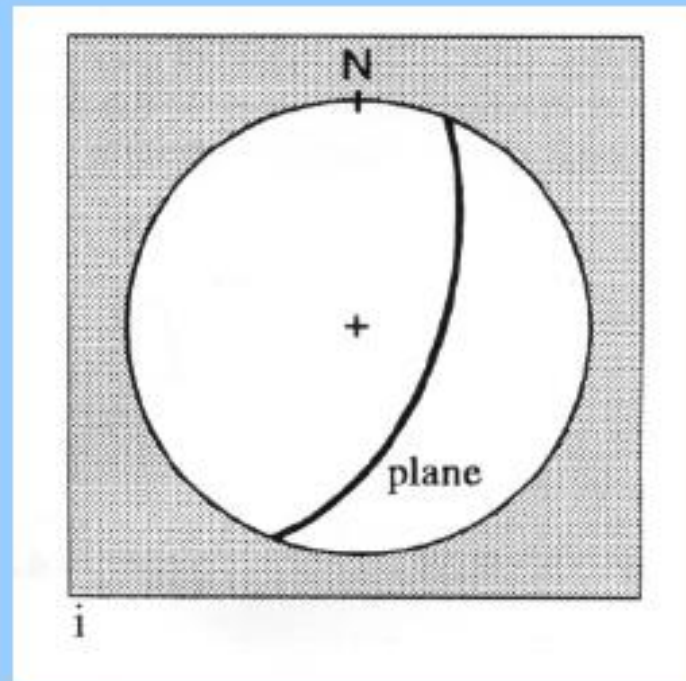
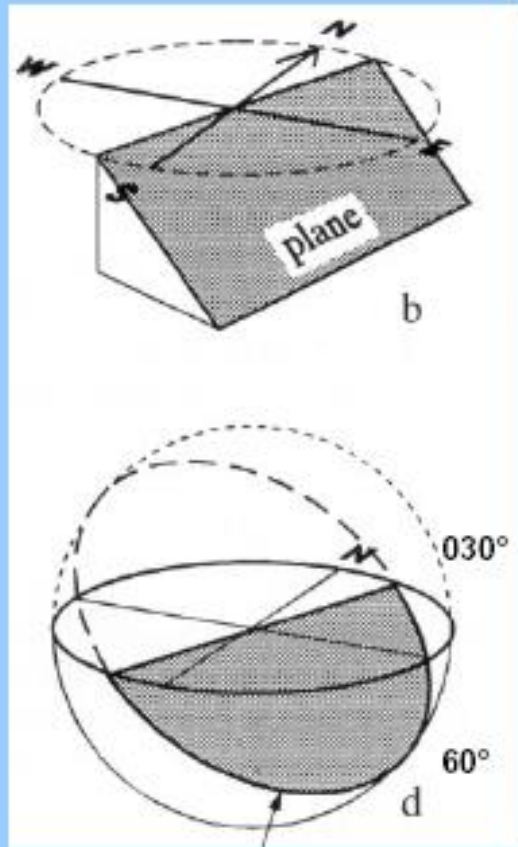

PLANE

1

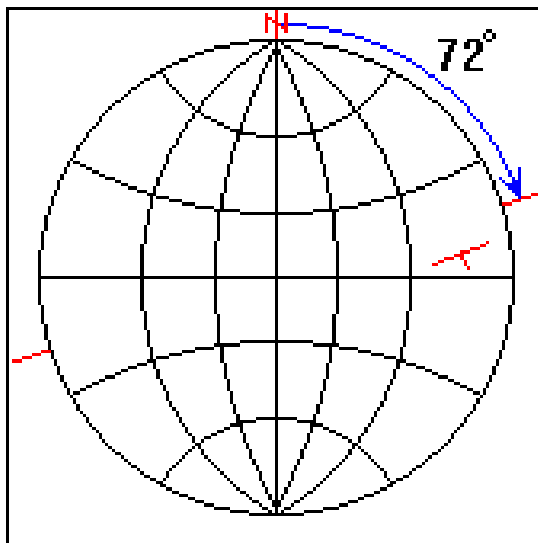

Strike = 072, Dip = 24 SE

2

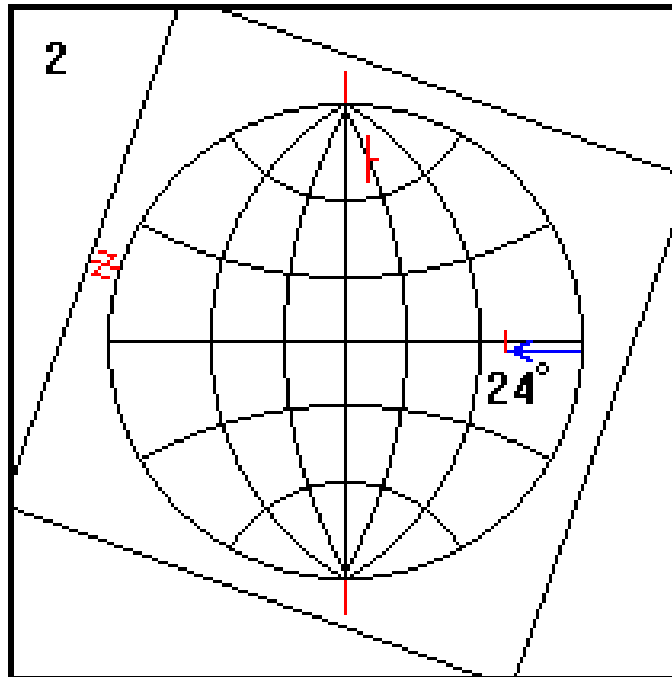

3

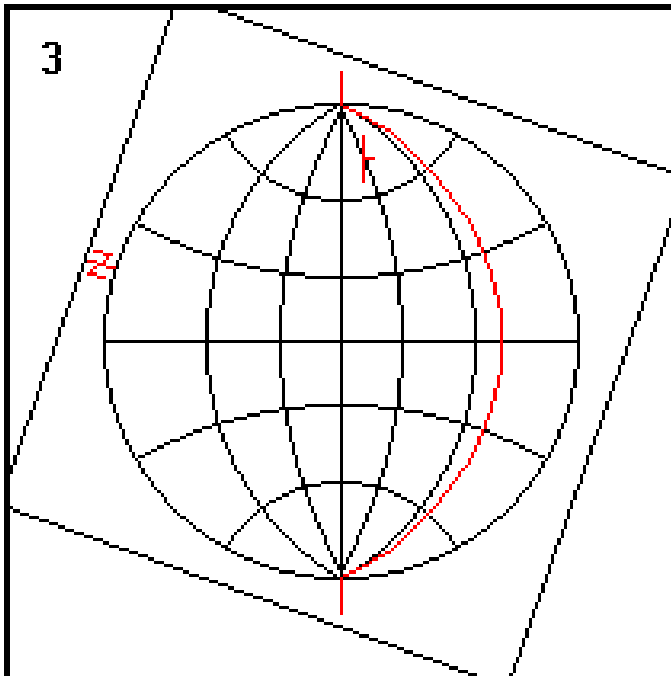

4

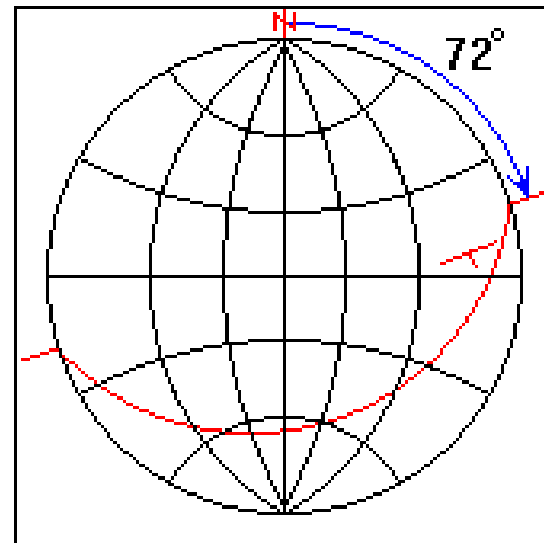

Strike = 072, Dip = 24 SE

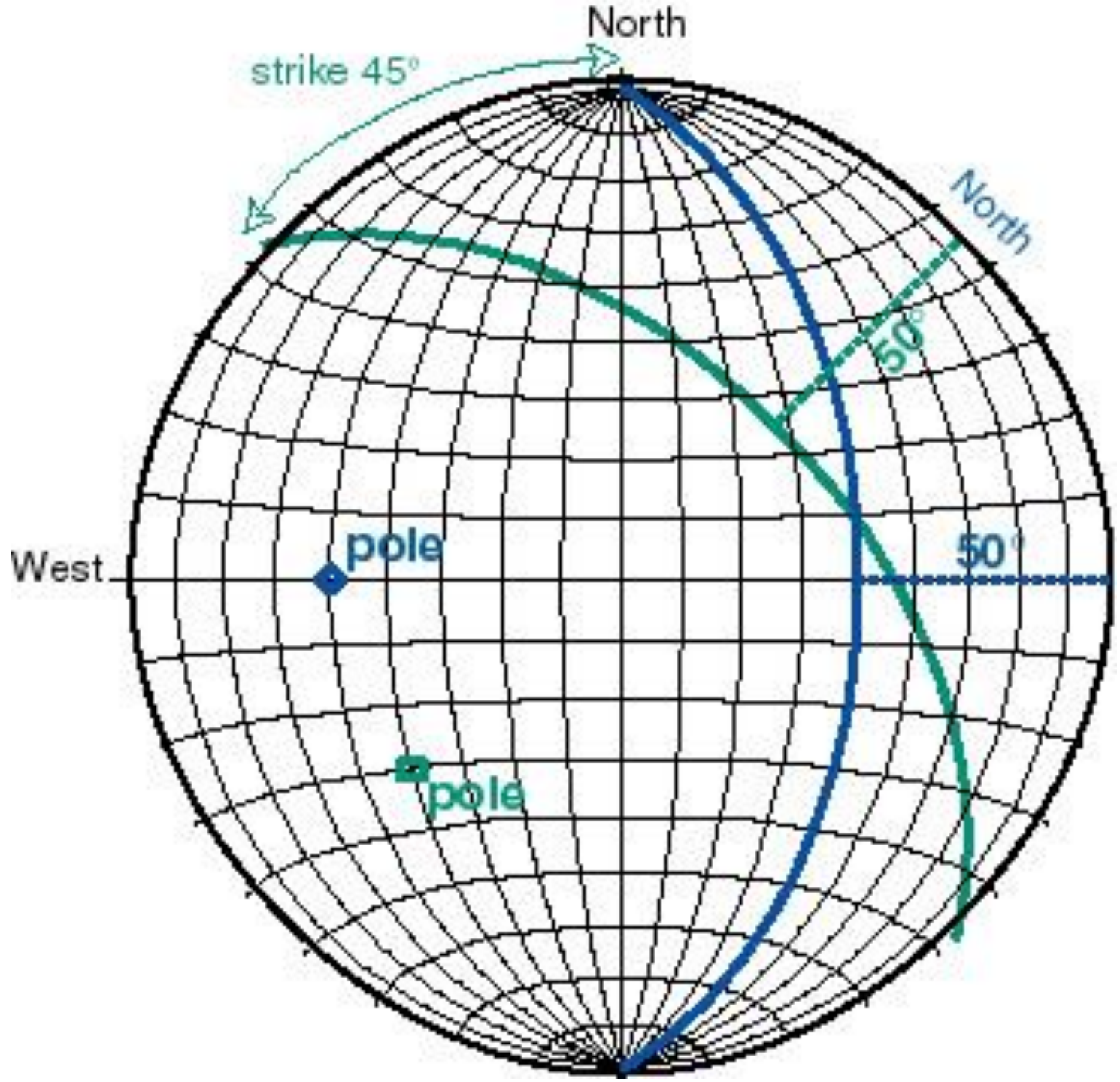

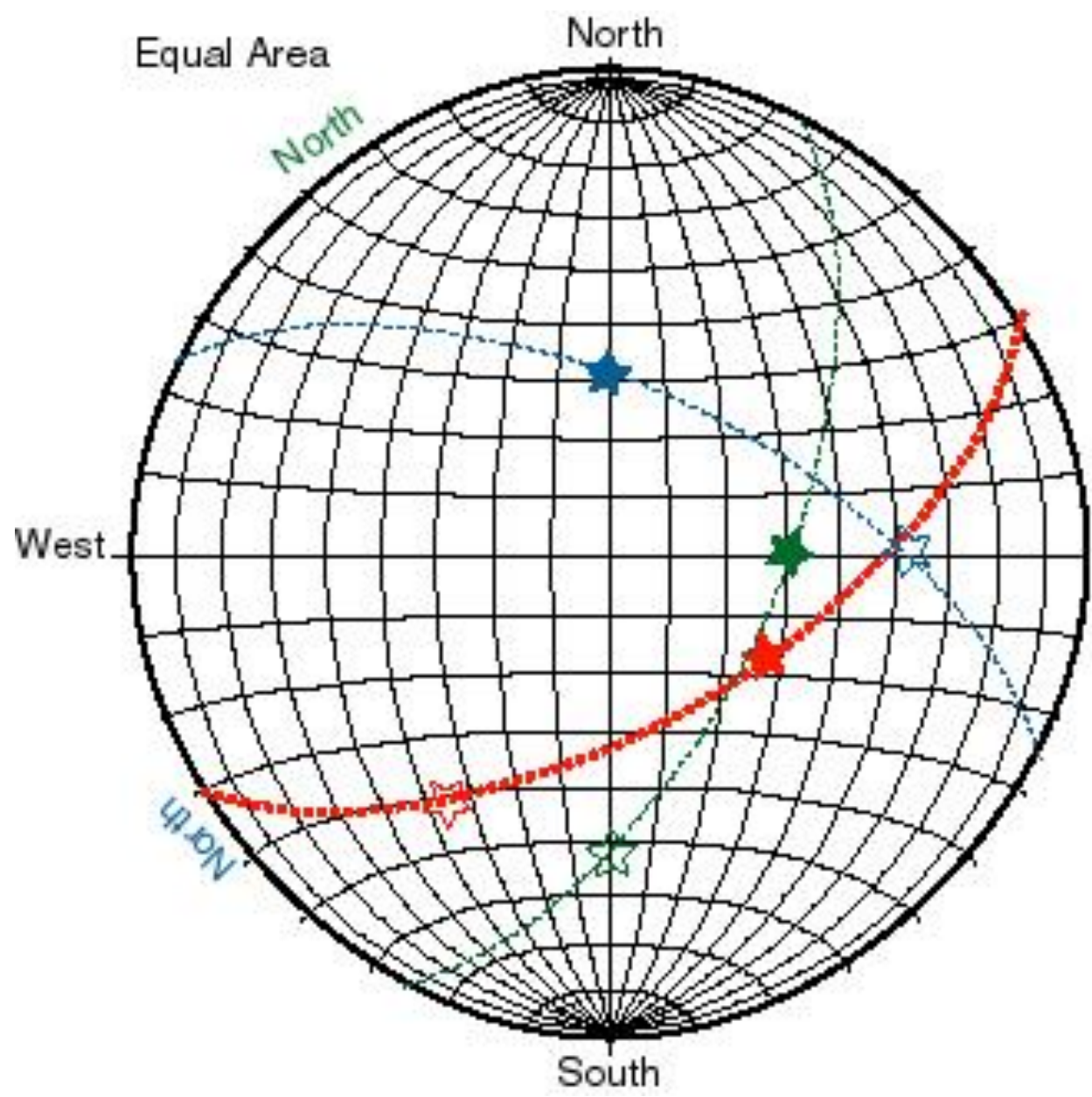

North

290 60E

75 70E

89 32

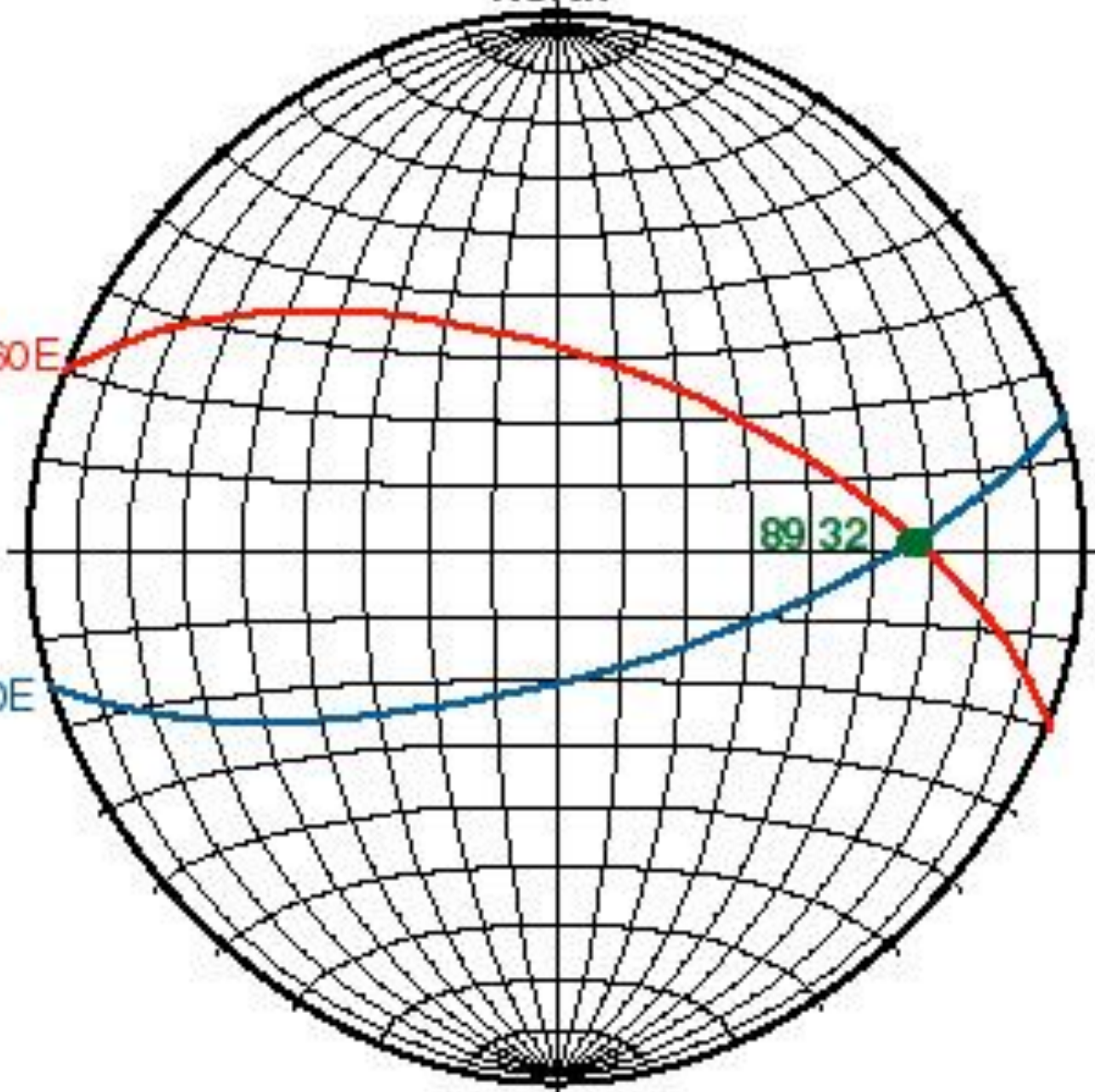

Equal Area

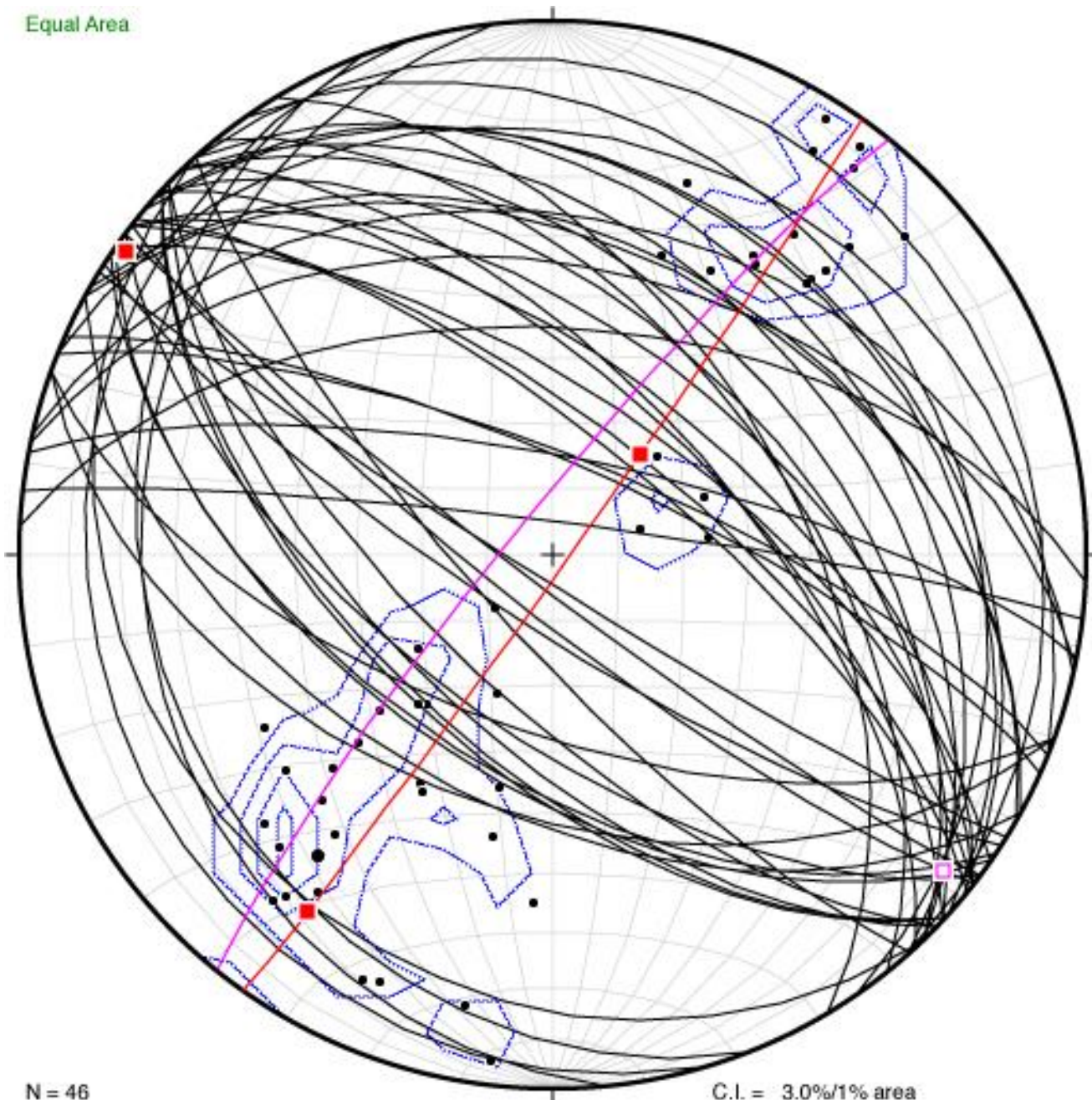

N = 46

C.I. = 3.0%/1% area

Intersection of Two Planes

Intersection of any two planes will produce a line in space
(provided they are not parallel)

- e.g. dike cross-cutting dipping strata

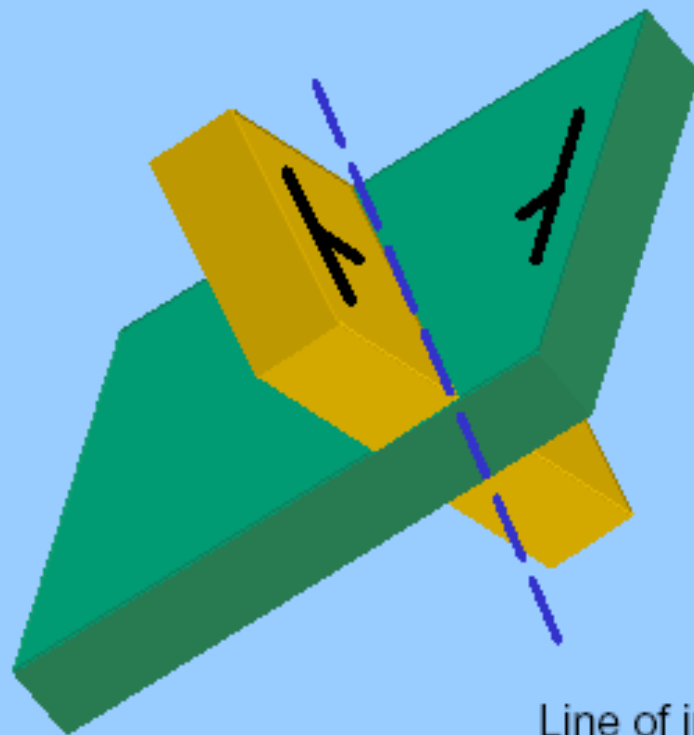

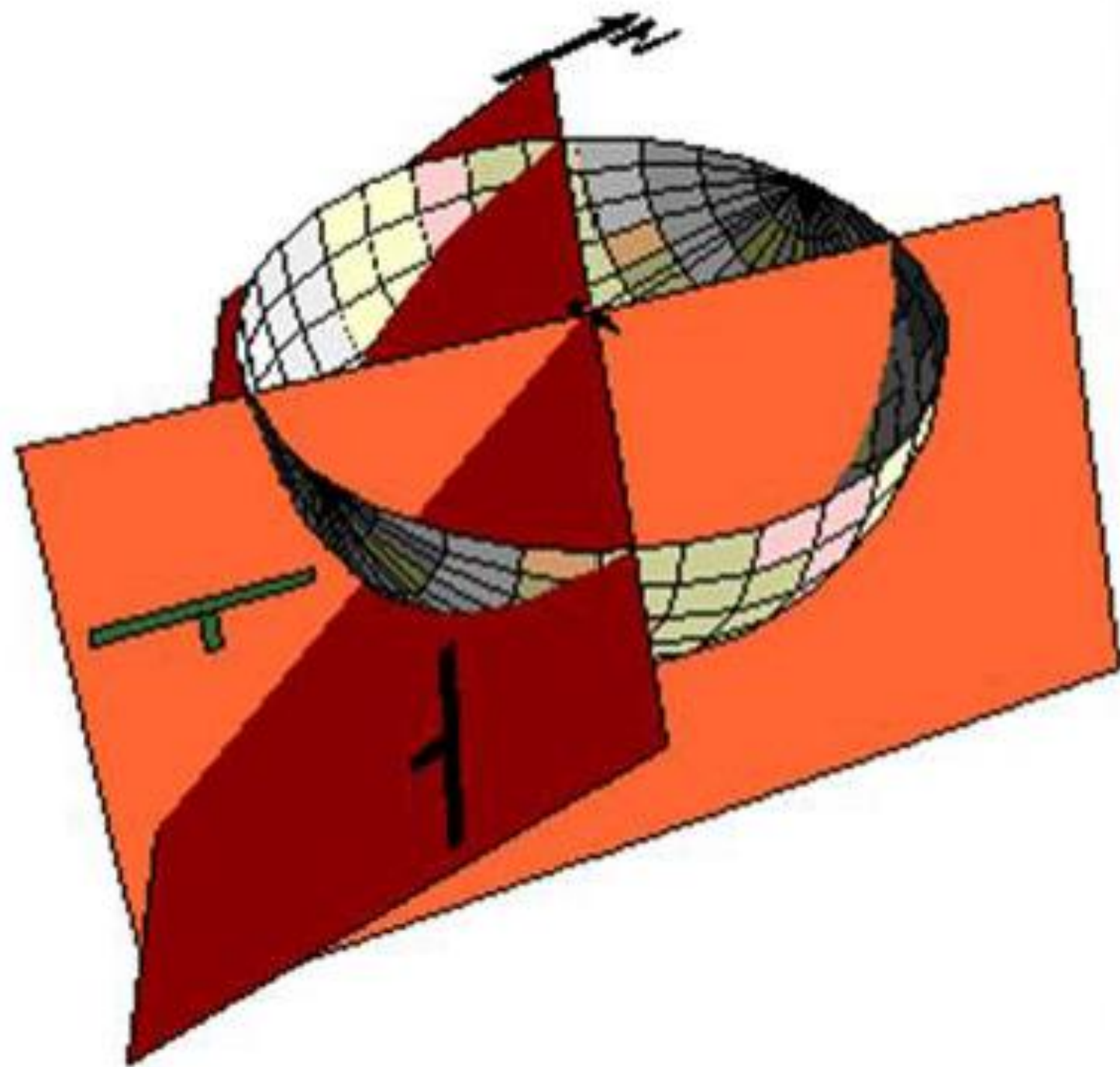

Intersecting planes

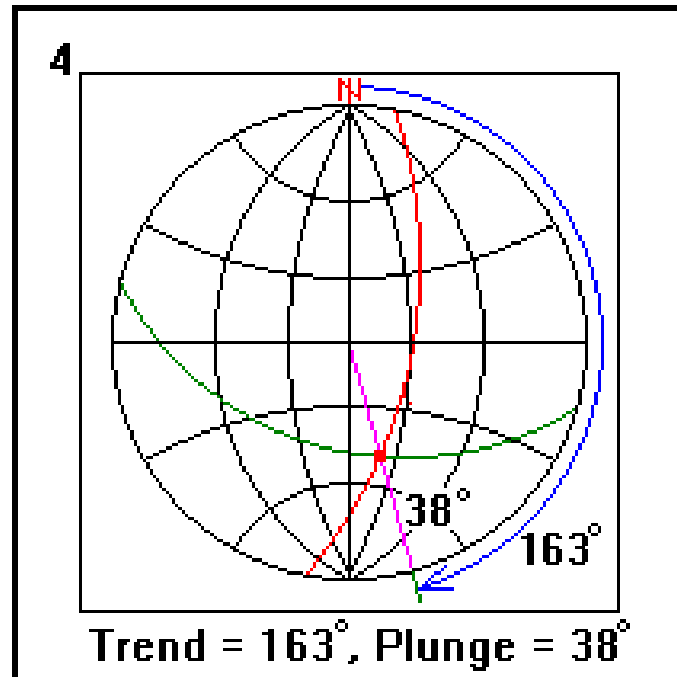
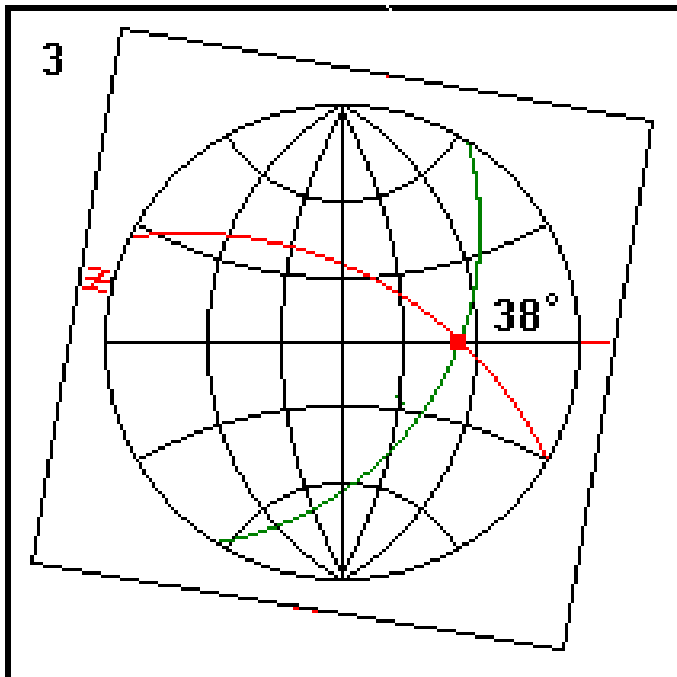
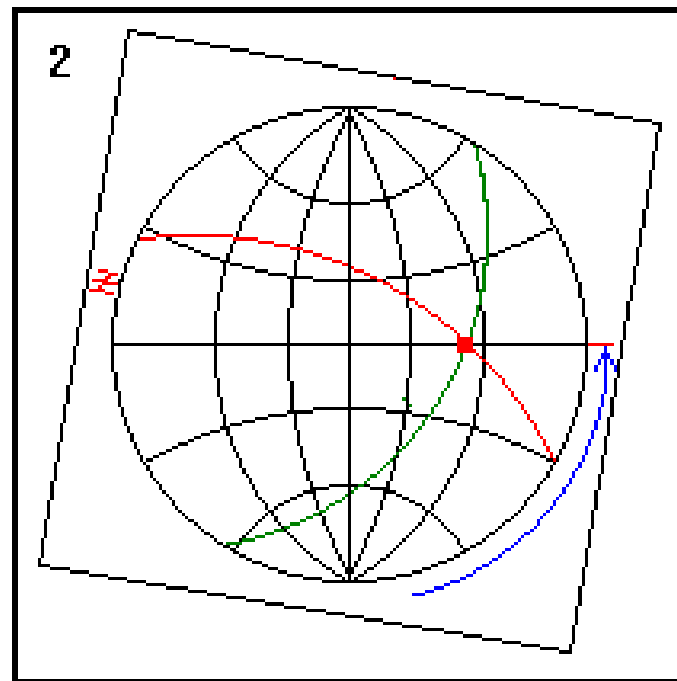
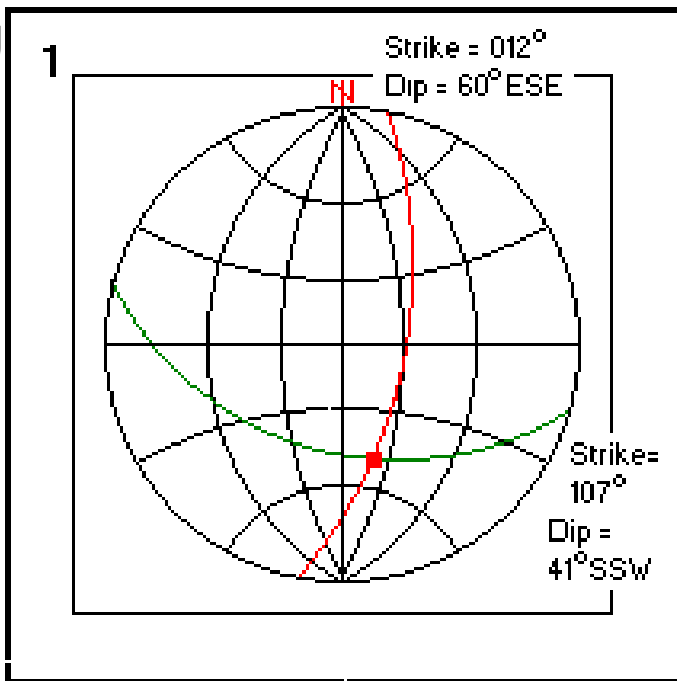

North

290 60E

89 32

75 70E

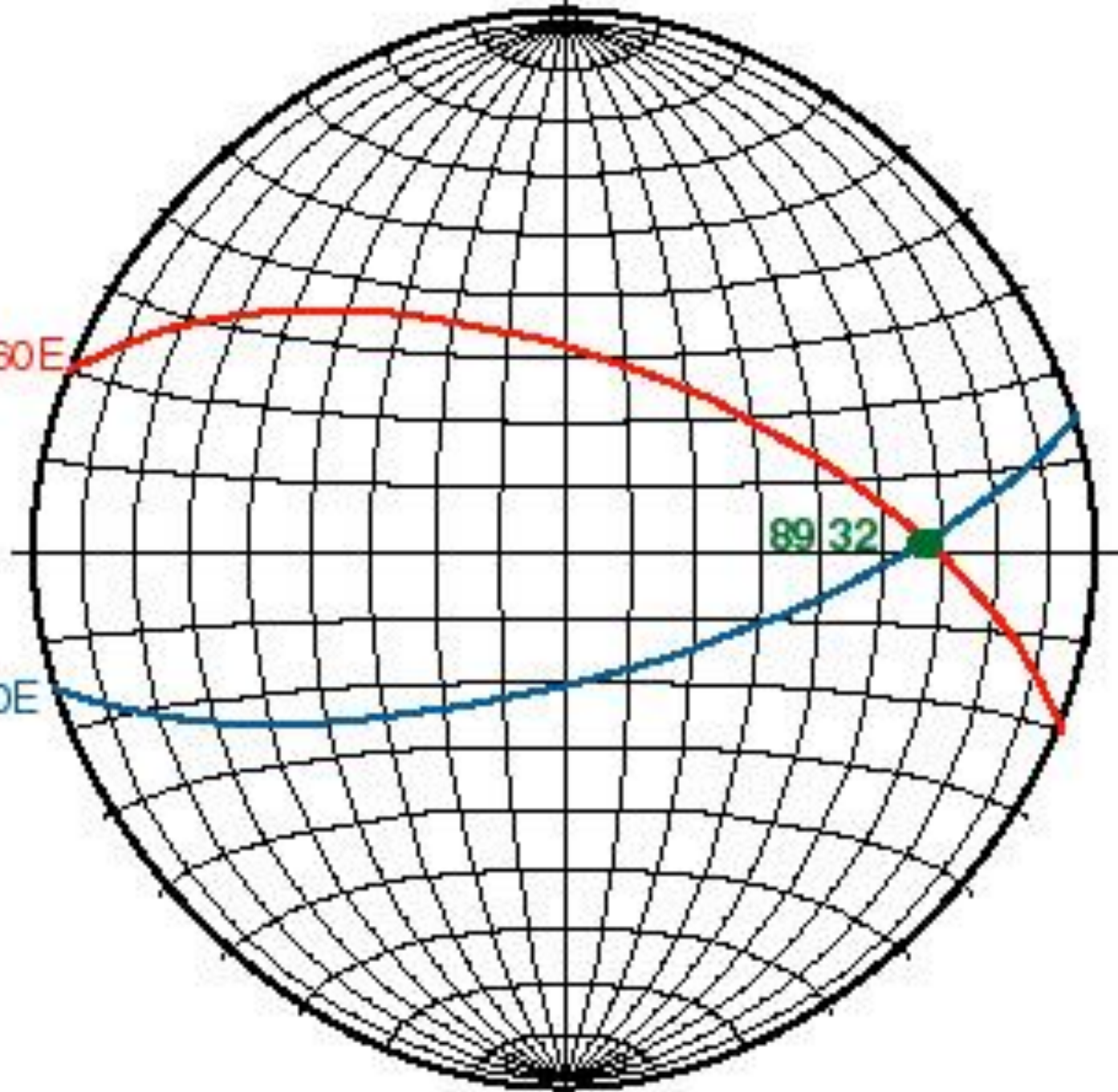

**End of Introduction to Concepts of
Stereographic Projections**