

The University of Zambia
School of Natural Sciences
Department of Physics
PHY 1015
Lecture 6B
Conservation of Linear momentum

Mr. Gift L. Sichone
Phone : +260764036560
Email : giftsichone@gmail.com

May 17, 2021

1 Introduction

This lesson introduces the principle of conservation of linear momentum and how its used to solve problems of simple interaction between bodies.

2 Learning Outcomes

The student should be able to:

1. state the principle of conservation of linear momentum;
2. apply the principle of conservation of linear momentum to solve simple problems,
3. define elastic and inelastic collisions between bodies in both one and two dimensions;
4. understand that, while total linear momentum of colliding bodies is always conserved, some change in kinetic energy may take place.

3 Principle of Conservation of Linear Momentum

The principle of conservation of linear momentum states that the total linear momentum is always conserved i.e. stays constant and is used to predict the motion of objects after either a collision or an explosion. The principle of conservation of linear momentum states that the total linear momenta (plural for momentum) of bodies before they collide or explode, is the sum total of all these linear momenta (accounting for their direction) will be the same as the total afterwards. This principle depends on the condition that no external force acts on the objects in question.

4 Conservation of Linear Momentum During Collisions

During a collision of two bodies with masses m_1 and m_2 , the sum of the linear momenta of the bodies in the x and y - direction before and after the collision is always the same. Therefore, if a body with mass m_1 travelling at speed u_1 collides with a body with mass m_2 with velocity u_2 , the two masses will proceed to move with velocities v_1 and v_2 after the collision. The total linear momenta of the bodies before and after the collision is always the same.

total linear momentum before collision = total linear momentum after collision

This conservation of linear momentum must be enforced in both the x and y -direction. Thus, it becomes important to find the components of the velocities of the masses in the x -direction (i.e. u_{1x} , u_{2x} , v_{1x} and v_{2x}) and in the y -direction (i.e. u_{1y} , u_{2y} , v_{1y} and v_{2y}).

In the x -direction, principle of conservation of linear momentum in a collision between two masses is expressed as

$$m_1u_{1x} + m_2u_{2x} = m_1v_{1x} + m_2v_{2x}$$

Similarly, in the y -direction, principle of conservation of linear momentum in a collision between two masses is expressed as

$$m_1u_{1y} + m_2u_{2y} = m_1v_{1y} + m_2v_{2y}$$

Note that the principle of conservation of linear momentum is always upheld.

However, the same conservation does not always work in the case of energy. If a body with mass is either at rest or is moving at a constant velocity, then the body in question has energy i.e. kinetic energy which is given by

$$KE = \frac{1}{2}mv^2 = \frac{p^2}{2m}$$

The total kinetic energy of the bodies before the collision and after the collision can be same or different. Collisions which result in the conservation of kinetic energy before and after the collision are called **perfectly elastic collisions**. Generally, there is always a loss of kinetic energy after the collision because though the total kinetic energy of the bodies cannot be destroyed, it can be converted into heat, sound or gravitational potential energy thereby resulting in a loss of total kinetic after a collision. These kinds of collisions in which there is a loss of kinetic energy are referred to as **inelastic collisions**.

In an elastic collision, there is conservation of total kinetic energy and thus obtain

$$\frac{1}{2}m_1u_1^2 + \frac{1}{2}m_2u_2^2 = \frac{1}{2}m_1v_1^2 + \frac{1}{2}m_2v_2^2$$

Example 1

A 8.0 g bullet fired horizontally into a 9.00 kg cube of wood, which is at rest, and sticks in it. The cube is forced to move and has a speed of 0.40 m/s after impact. Find the initial velocity of the bullet?

Solution

Let the mass of the bullet be denoted $m_b = 8.0 \text{ g} = 0.008 \text{ kg}$.

Let the unknown velocity of the bullet before impact be denoted u_b .

Let the mass of the wooden cube be denoted $m_w = 9.00 \text{ kg}$.

Let the velocity of the wooden cube be denoted u_w . Since the wooden cube is at rest before impact, then $u_w = 0 \text{ m/s}$.

The total linear momentum before impact is given by

$$m_bu_b + m_wu_w = (0.008 \text{ kg})u_b + (9.00 \text{ kg})(0 \text{ m/s}) = (0.008 \text{ kg})u_b$$

After impact the bullet and the wooden cube stick together and move with a velocity of 0.40 m/s.

Let us denote the combined mass of the bullet and the wooden cube as $m_b + m_w$ where

$$m_b + m_w = 0.008 \text{ kg} + 9.00 \text{ kg} = 9.008 \text{ kg}$$

Similarly, let us denote the velocity of the wooden cube with bullet stuck in it after as $v = 0.40 \text{ m/s}$.

The total linear momentum after impact is given by

$$(m_b + m_w)v = (9.008 \text{ kg})(0.4 \text{ m/s}) = 3.6032 \text{ kg m/s}$$

Since the total linear momentum is always conserved i.e the total linear momentum before impact is equal to the total linear momentum after impact, we get

total linear momentum before impact = total linear momentum after impact

$$(0.008 \text{ kg})u_b = 3.6032 \text{ kg m/s}$$

By making u_b the subject of the formula, we get

$$u_b = \frac{3.6032 \text{ kg m/s}}{0.008 \text{ kg}} = 450 \text{ m/s}$$

Therefore, we find the initial velocity of the bullet to be 450 m/s.

Example 2

A 16.0 g mass is moving in the positive x -direction at 0.3 m/s while a 4.0 g mass is moving in the negative x -direction at 0.5 m/s. They collide head-on and stick together. Find their velocity after collision.

Let the mass of the object moving in the positive x -direction be denoted as $m_1 = 16 \text{ g} = 0.016 \text{ kg}$. Mass is a scalar quantity, it has no direction. Since the object is moving at a velocity of 0.3 m/s in the positive x -direction before colliding, we denote its velocity as $u_1 = +0.3 \text{ m/s}$. The 0.3 m/s is the magnitude of the velocity and the + sign shows the direction i.e. positive x -direction. Unlike mass, it is possible to give direction to velocity in terms of either a + or - sign because velocity is a vector quantity.

Similarly, let the mass of the object moving in the negative x -direction be denoted $m_2 = 4.0 \text{ g} = 0.004 \text{ kg}$. Since the mass is moving in the negative x -direction, we denote its velocity before collision as $u_2 = -0.5 \text{ m/s}$.

We calculate the total linear momentum before collision as

$$m_1u_1 + m_2u_2 = (0.016 \text{ kg})(+0.3 \text{ m/s}) + (0.004 \text{ kg})(-0.5 \text{ m/s}) = 0.0028 \text{ kg m/s}$$

After the collision, the masses m_1 and m_2 stick together and move with unknown velocity v . Therefore, the total linear momentum after the collision is given by

$$(m_1 + m_2)v = (0.016 \text{ kg} + 0.004 \text{ kg})v = (0.02 \text{ kg})v$$

Since the linear momentum during a collision is always conserved, we get

total linear momentum before collision = total linear momentum after collision

$$0.0028 \text{ kg m/s} = (0.02 \text{ kg})v$$

We get the velocity after collision v as

$$v = \frac{0.0028 \text{ kg m/s}}{0.02 \text{ kg}} = 0.14 \text{ m/s}$$

Their velocity after collision is 0.14 m/s.

Example 3

A 0.25 kg ball moving in the positive x -direction at 13.0 m/s is kicked by a footabller. Its final velocity is 19 m/s in the negative x -direction. If the kick on the ball lasted for 0.010 s. Find the average force F exerted on the ball by the kick.

Solution

Let the mass of the ball be denoted $m = 0.25 \text{ kg}$.

The let velocity of the ball before being kicked be denoted $u = +13.0 \text{ m/s}$. The + sign in the velocity is because the ball is moving in the positive x -direction.

Let the velocity of the ball after being kicked be denoted $v = -19.0 \text{ m/s}$. The - sign in the velocity is because the ball is moving in the negative x -direction after being picked.

So, we see that the velocity of the ball changes from $u = +13.0 \text{ m/s}$ to $v = -19.0 \text{ m/s}$. This is a change in linear momentum of the ball also known as impulse. We find the impulse denoted Δp as

$$\Delta p = mv - mu$$

$$\Delta p = (0.25 \text{ kg})(-19.0 \text{ m/s}) - (0.25 \text{ kg})(+13.0 \text{ m/s})$$

$$\Delta p = -8 \text{ kg m/s}.$$

The impulse Δp is also given as a product of force F exerted on the ball and the length of time t the ball is kicked. We get Δp as

$$\Delta p = Ft = -8 \text{ kg m/s}.$$

Since $t = 0.010$ s, we get

$$F(0.010 \text{ s}) = -8 \text{ kg m/s.}$$

We get the average force F as

$$F = \frac{-8 \text{ kg m/s}}{0.010 \text{ s}} = -800 \text{ N}$$

The footballer's kick exerts a force of 800 N directed opposite the motion of the ball before it was kicked.

Example 4

A 40 000 kg freight car is coasting at a speed of 5.0 m/s along a straight track when it strikes a 30 000 kg stationary freight car and couples to it. What will be their combined speed after impact?

Solution

Let the mass of the moving freight car be denoted $m_1 = 40\,000$ kg.

Let the velocity of moving freight car before impact be denoted $u_1 = 5.0$ m/s.

Let the mass of the stationary freight car be denoted $m_2 = 30\,000$ kg.

Let the velocity of the stationary freight car before impact be denoted $u_2 = 0$ m/s.

The total linear momentum before impact is given by

$$m_1 u_1 + m_2 u_2 = (40\,000 \text{ kg})(5.0 \text{ m/s}) + (30\,000 \text{ kg})(0 \text{ m/s})$$

$$m_1 u_1 + m_2 u_2 = 200\,000 \text{ kg m/s}$$

After the impact, the freight cars couple therefore have a combined mass $m_1 + m_2$ and continue to move with unknown velocity v .

The total linear momentum after impact is given by

$$(m_1 + m_2)v = (40\,000 \text{ kg} + 30\,000 \text{ kg})v = (70\,000 \text{ kg})v$$

Since the total linear momentum is always conserved i.e total linear momentum before impact equal to total linear momentum after impact, we get

$$200\,000 \text{ kg m/s} = (70\,000 \text{ kg})v$$

We find the velocity v by making it the subject of the formula

$$v = \frac{200\,000 \text{ kg m/s}}{70\,000 \text{ kg}} = 2.85 \text{ m/s}$$

$$v \approx 2.9 \text{ m/s}$$

The combined speed of the freight cars after impact is $v \approx 2.9$ m/s.

Example 5

A 7.0 g bullet moving horizontally at 200 m/s strikes and passes through a 150 g tin can sitting on a post. Just after impact, the can has a horizontal speed of 1.80 m/s. What was the bullet's speed after leaving the can?

Solution Let the mass of the bullet be denoted $m_1 = 7.0 \text{ g} = 0.007 \text{ kg}$.

Let the velocity of the bullet before striking the can be denoted $u_1 = 200 \text{ m/s}$.

Let the mass of the tin can be denoted $m_2 = 150 \text{ g} = 0.15 \text{ kg}$.

Let the velocity of the tin can on the post be denoted $u_2 = 0 \text{ m/s}$.

The total linear momentum before impact is given by

$$m_1u_1 + m_2u_2 = (0.007 \text{ kg})(200 \text{ m/s}) + (0.15 \text{ kg})(0 \text{ m/s})$$

$$m_1u_1 + m_2u_2 = 1.4 \text{ kg m/s}$$

After impact, the bullet exits the tin can with unknown velocity v_1 and the tin can flies off with velocity $v_2 = 1.80 \text{ m/s}$.

The total linear momentum after impact is given by

$$m_1v_1 + m_2v_2 = (0.007 \text{ kg})v_1 + (0.15 \text{ kg})(1.80 \text{ m/s})$$

$$m_1v_1 + m_2v_2 = (0.007 \text{ kg})v_1 + 0.27 \text{ kg m/s}$$

Since the total linear momentum before and after the impact is always conserved, we get

$$m_1u_1 + m_2u_2 = m_1v_1 + m_2v_2$$

This gives

$$1.4 \text{ kg m/s} = (0.007 \text{ kg})v_1 + 0.27 \text{ kg m/s}$$

Simplifying, we get

$$(0.007 \text{ kg})v_1 = 1.4 \text{ kg m/s} - 0.27 \text{ kg m/s}$$

$$(0.007 \text{ kg})v_1 = 1.13 \text{ kg m/s}$$

Solving for v_1 by making it the subject of the formula, we get

$$v_1 = \frac{1.13 \text{ kg m/s}}{0.007 \text{ kg}} = 161 \text{ m/s}.$$

The bullet leaves the tin can with a speed of 161 m/s.

Example 6

Two identical balls collide head-on. If the initial velocity of one is 0.75 m/s east, while that of the other is 0.43 m/s west. If the collision is perfectly elastic, what is the final velocity of each ball?

The two balls are identical, thus their mass masses are equal. i.e. $m_1 = m_2 = m$.

The first ball is moving towards the east while the second ball is moving in the opposite direction towards the west. If we choose the east direction to be positive, then the first ball has velocity $u_1 = +0.75$ m/s before impact. Similarly, the second ball will have velocity $u_2 = -0.43$ m/s before impact.

We can work out the total linear momentum and total kinetic energy of the two balls before impact.

The total linear momentum before impact is given by

$$m_1u_1 + m_2u_2$$

However, since the two balls are identical, we get the total linear momentum as

$$m_1u_1 + m_2u_2 = mu_1 + mu_2 = m(u_1 + u_2)$$

The total kinetic energy of the two balls before impact is given by

$$\frac{1}{2}m_1u_1^2 + \frac{1}{2}m_2u_2^2$$

Similarly, since the two balls are identical, we get the total kinetic energy as

$$\frac{1}{2}m_1u_1^2 + \frac{1}{2}m_2u_2^2 = \frac{1}{2}m(u_1^2 + u_2^2)$$

After impact, the two balls bounce off each other and continue in a direction opposite their original direction of motion with velocities v_1 and v_2 respectively.

We get the total linear momentum after impact as

$$m(v_1 + v_2)$$

Since total linear momentum is conserved in a collision, we get

$$m(u_1 + u_2) = m(v_1 + v_2)$$

Cancelling out the m , on both side we get

$$u_1 + u_2 = v_1 + v_2$$

or

$$v_1 + v_2 = u_1 + u_2 = +0.75 \text{ m/s} + (-0.43 \text{ m/s})$$

$$v_1 + v_2 = 0.32 \text{ m/s}$$

Dropping the units, we get a more compact form of the above equation

$$v_1 + v_2 = 0.32$$

Similarly, the total kinetic energy of the two balls after impact is given by

$$\frac{1}{2}m_1v_1^2 + \frac{1}{2}m_2v_2^2$$

Since the two balls are identical, we get the total kinetic energy as

$$\frac{1}{2}m_1v_1^2 + \frac{1}{2}m_2v_2^2 = \frac{1}{2}m(v_1^2 + v_2^2)$$

Now, this collision is perfectly elastic. This means that the total kinetic energy of the two balls before and after the impact is conserved. We therefore get

$$\frac{1}{2}m(u_1^2 + u_2^2) = \frac{1}{2}m(v_1^2 + v_2^2)$$

Cancelling out the $\frac{1}{2}m$, on both side we get

$$u_1^2 + u_2^2 = v_1^2 + v_2^2$$

$$v_1^2 + v_2^2 = (+0.75 \text{ m/s})^2 + (-0.43 \text{ m/s})^2$$

$$v_1^2 + v_2^2 = 0.7474 \text{ m}^2/\text{s}^2$$

Dropping the units, we get a more compact form of the above equation

$$v_1^2 + v_2^2 = 0.7474$$

Making v_2 the subject of the formula from $v_1 + v_2 = 0.32$, we get

$$v_2 = 0.32 - v_1$$

Substituting for v_2 in $v_1^2 + v_2^2 = 0.7474$, we get

$$v_1^2 + (0.32 - v_1)^2 = 0.7474$$

Expanding, we get

$$v_1^2 + (0.32 - v_1)(0.32 - v_1) = 0.7474$$

$$v_1^2 + 0.32^2 - 0.32v_1 - 0.32v_1 + v_1^2 - 0.7474 = 0$$

$$2v_1^2 - 0.64v_1 - 0.645 = 0$$

This the above equation has the form $ax^2 + bx + c = 0$ which is a quadratic equation. In our case $x = v_1$, $a = 2$, $b = -0.64$ and $c = -0.645$.

We proceed to use the quadratic formula, which is given by

$$x = \frac{-b \pm \sqrt{b^2 - 4ac}}{2a}$$

Substituting, the appropriate values, we get

$$v_1 = \frac{-(-0.64) \pm \sqrt{(-0.64)^2 - 4(2)(-0.645)}}{2(2)}$$

$$v_1 = \frac{0.64 \pm \sqrt{0.4096 + 5.16}}{4}$$

$$v_1 = \frac{0.64 \pm 2.36}{4}$$

Thus we get

$$v_1 = \frac{0.64 + 2.36}{4} \quad \text{or} \quad v_1 = \frac{0.64 - 2.36}{4}$$

$$v_1 = 0.75 \quad \text{or} \quad v_1 = -0.43$$

$$v_1 = 0.75 \text{ m/s} \quad \text{or} \quad v_1 = -0.43 \text{ m/s}$$

As you can see, we have two solutions for the velocity of the first ball. Mathematically, both solutions are correct, but in the world of Physics, the solution $v_1 = +0.75 \text{ m/s}$ is not possible. This solution somehow implies that even after undergoing a perfectly elastic collision, the first ball somehow continued moving east at 0.75 m/s . Therefore, we discard

the solution $v_1 = +0.75$ m/s and return $v_1 = -0.43$ m/s. The - sign shows that the first ball bounced back after the collision and started heading west which matches with reality.

After find the velocity of the first ball after the collision as $v_1 = -0.43$ m/s. we can substitute back into $v_1 + v_2 = 0.32$, to obtain v_2

$$v_2 = 0.32 - v_1$$

$$v_2 = 0.32 - (-0.43) = 0.75$$

$$v_2 = 0.75 \text{ m/s}$$

The second ball bounces off and moves east with velocity $v_2 = 0.75$ m/s.

Example 7

As shown in Fig. 1, a 15 g bullet is fired horizontally into a 3.0 kg block of wood suspended on a long cord. The bullet sticks in the wooden block. Compute the speed of the bullet if the impact causes the bullet to swing 10 cm above the initial level.

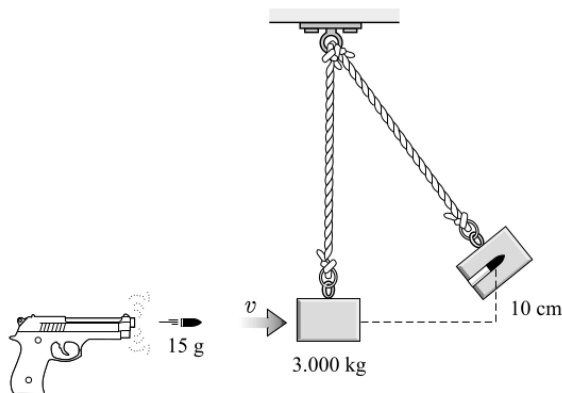

Figure 1: A bullet fired from a pistol

Let the mass of the bullet be denoted $m_1 = 15 \text{ g} = 0.015 \text{ kg}$.

Let the unknown velocity of the bullet before it strikes the wooden cube be denoted by u_1 .

Let the mass of the wooden cube be denoted $m_2 = 3.0 \text{ kg}$. Since the wooden cube is stationary before it is struck by the bullet, its velocity is denoted $u_2 = 0 \text{ m/s}$.

The total linear momentum before impact is given by

$$m_1u_1 + m_2u_2 = (0.015 \text{ kg})u_1 + (3.0 \text{ kg})(0 \text{ m/s})$$

$$m_1u_1 + m_2u_2 = (0.015 \text{ kg})u_1$$

After the bullet hits the wooden cube, it gets stuck in the wooden cube. The combined mass of the bullet and the wooden cube is now $m_1 + m_2 = 3.015 \text{ kg}$. The wooden cube with the lodged bullet does not stay stationary after being hit but moves with velocity v .

Therefore, we can work out the total linear momentum after impact as

$$(m_1 + m_2)v = (3.015 \text{ kg})v$$

Since the total linear momentum is always conserved, we get

$$(0.015 \text{ kg})u_1 = (3.015 \text{ kg})v$$

After impact, the wooden cube and lodged bullet have kinetic energy given by

$$KE = \frac{1}{2}(m_1 + m_2)v^2 = \frac{1}{2}(3.015 \text{ kg})v^2$$

$$KE = (1.5075 \text{ kg})v^2$$

When the wooden cube and the lodged bullet rise to the height of 10 cm, the velocity of the wooden cube and lodged bullet reduces to 0 m/s. This shows that the Kinetic energy of the wooden cube and lodged bullet is converted into gravitational potential energy(GPE). Since we know the mass of the wooden cube and lodged bullet as well as the height to which they rise, i.e. $h = 10 \text{ cm} = 0.1 \text{ m}$, we can calculate the change in GPE as

$$\Delta GPE = (m_1 + m_2)gh = (3.015 \text{ kg})(9.8 \text{ m/s}^2)(0.10 \text{ m})$$

$$\Delta GPE \approx 2.95 \text{ J}$$

Using the law of conservation of energy, we know that the change in kinetic energy is equal to the change in GPE. Thus we have

$$\Delta KE = \Delta GPE$$

where ΔKE is the change in kinetic energy of the wooden cube lodged with bullet and is given by

$$\Delta KE = (1.5075 \text{ kg})v^2$$

at this moment, we are only concerned with the size of energy change. if the energy change is negative, then the energy was lost and if positive then it was gained.

Therefore, we get

$$(1.5075 \text{ kg})v^2 = 2.95 \text{ J}$$

Working out the velocity v , by making the subject of the formula, we get

$$v^2 = \frac{2.95 \text{ J}}{1.5075 \text{ kg}}$$

$$v = \sqrt{\frac{2.95 \text{ J}}{1.5075 \text{ kg}}} = 1.4 \text{ m/s}$$

So, after impact the wooden cube and bullet have a velocity $v = 1.4 \text{ m/s}$

Now, recall that from conservation of total linear momentum that

$$(0.015 \text{ kg})u_1 = (3.015 \text{ kg})v$$

Making u_1 the subject of the formula, we get

$$u_1 = \frac{(3.015 \text{ kg})v}{0.015 \text{ kg}}$$

Substituting in the value of v , we get

$$u_1 = \frac{(3.015 \text{ kg})(1.4 \text{ m/s})}{0.015 \text{ kg}} = 281.4 \text{ m/s.}$$

The speed of the bullet when it exits the pistol is $\approx 281 \text{ m/s}$.

5 Conservation of Linear Momentum During Explosions

There is also conservation of linear momentum during explosions. For example, if the explosive has mass m and is at rest i.e. $u = 0$, the total linear momentum before the explosion is definitely zero. Since, the principle of conservation of linear momentum is always obeyed, the explosive will have to explode in different directions in such a manner that the total linear momenta of the bomb fragments add up to zero. Therefore, we obtain

total linear momentum before explosion = total linear momentum after explosion

For example, consider the case in which an explosive breaks up into 3 smaller particles, with masses m_1 , m_2 and m_3 after the explosion moving with velocities

v_1 , v_2 and v_3 respectively. We can enforce conservation of linear momentum in this case as follows:

In the x -direction, we enforce conservation of linear momentum before and after the explosion and obtain

$$mu_x = m_1v_{1x} + m_2v_{2x} + m_3v_{3x}$$

Since the explosive was at rest, before the explosion therefore $u_x = 0 \text{ m s}^{-1}$. Therefore, we obtain

$$0 = m_1v_{1x} + m_2v_{2x} + m_3v_{3x}$$

Similarly, in the y -direction, we enforce conservation of linear momentum before and after the explosion and obtain

$$mu_y = m_1v_{1y} + m_2v_{2y} + m_3v_{3y}$$

Again, since the explosive was at rest, before the explosion therefore $u_y = 0 \text{ m s}^{-1}$. Therefore, we obtain

$$0 = m_1v_{1y} + m_2v_{2y} + m_3v_{3y}$$