



1 Evaluate  $3^2 + 3^{-1} \times 2^0$

Answer:.....[2]

2 Simplify  $2(x + y) - 3(4x - 2)$

Answer:.....[2]

3 Factorise completely  $3x^2 - 27$

Answer:.....[2]

4 Find the gradient of a line which passes through the points  $(-3,1)$  and  $(0,3)$ .

Answer:.....[2]

5 Shade  $(A \cup B) \cap C'$  on the Venn diagram in the answer space below.

[www.eczpastpapers.com](http://www.eczpastpapers.com)

Answer:

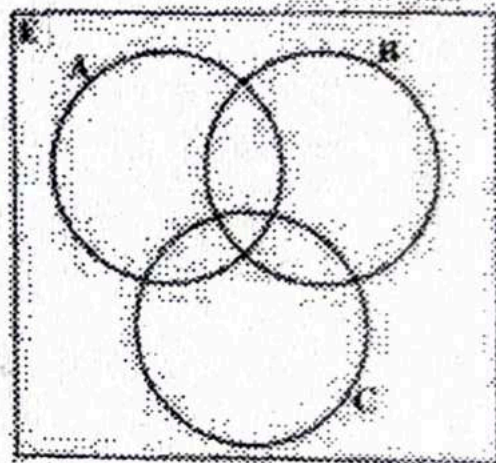

[2]

6 The position vector of a point P is  $\begin{pmatrix} 3 \\ 4 \end{pmatrix}$ . Given that point Q is  $(-1,1)$  find  $\overrightarrow{PQ}$ .

Answer:.....[2]

7 Given that  $P = \begin{pmatrix} 4 & -1 & 0 \\ 2 & 0 & 3 \end{pmatrix}$  and  $Q = \begin{pmatrix} 1 \\ 2 \\ 3 \end{pmatrix}$ , find

- (a)  $P^T$   
 (b)  $PQ$

Answer: (a).....[1]  
 (b).....[2]

8 An Arithmetic Progression is given as 1, 7, 13, ... Find the  
 (a) eighth term,  
 (b) sum of the first fifteen terms.

Answer: (a).....[1]  
 (b).....[2]

9 (a) In a bag there are 4 blue marbles, 3 red marbles and 2 white marbles. What is the probability of picking at random a red marble?  
 (b) Solve the equation  $2x^2 + x - 3 = 0$

Answer: (a).....[1]  
 (b).....[2]

10 (a) The universal set  $E = \{0, 1, 2, 3, 4, 5, 6, 7, 8, 9\}$ ,  
 set  $A = \{\text{prime numbers}\}$  and set  $B = \{3, 6, 9\}$

(b) The following diagram shows a regular hexagonal right pyramid.

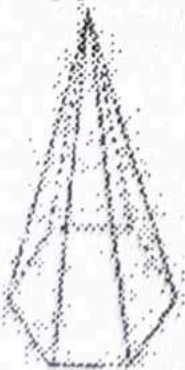

Answer: (a).....[1]  
 (b).....[2]

Find the number of planes of symmetry of the pyramid.

- 11 (a) Towns A and B are on longitudes  $75^\circ\text{W}$  and  $45^\circ\text{E}$  respectively. Find the time difference between these towns
- (b) The diagram shows  $P(45^\circ\text{S}, 75^\circ\text{W})$  and  $Q(0^\circ, 75^\circ\text{W})$ .

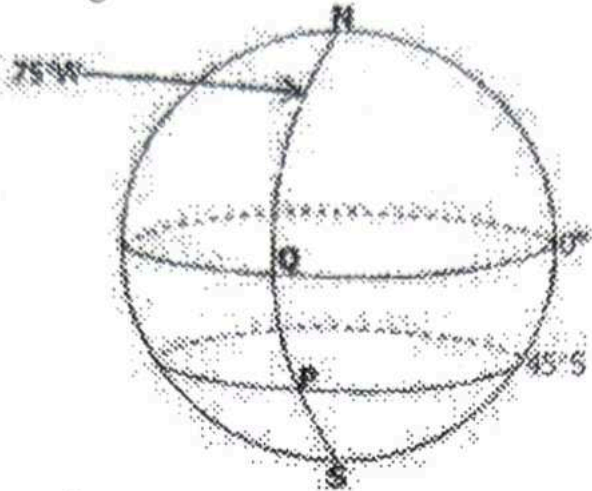

An aeroplane took  $4\frac{1}{2}$  hours to fly from town P to town Q. Find its average speed in knots.

Answer: (a).....[1]

(b).....[2]

[www.eczpastpapers.com](http://www.eczpastpapers.com)

- 12 (a) Solve  $5^{-3x} = 125$
- (b) The diagram shows a sector XOY. The angle subtended at the centre is  $70^\circ$  and the radius is 18cm.

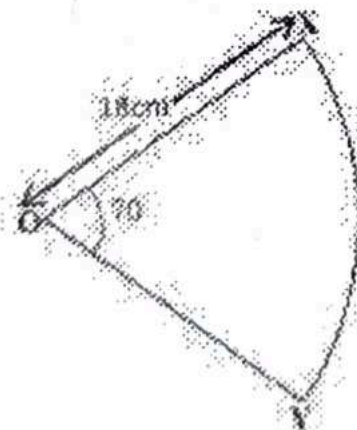

Calculate the area of the sector XOY.  $[\pi = \frac{22}{7}]$

Answer: (a).....[2]

(b).....[2]

- 13 The mass of a bag of mealie meal is 25.2kg. Calculate the  
 (a) Tolerance,  
 (b) Relative error

Answer: (a).....[2]

(b).....[2]

- 14 In the diagram, three points A, B and C are on level ground. The bearing of B from A is  $035^\circ$ , angle  $ABC = 90^\circ$  and angle  $ACB = 40^\circ$

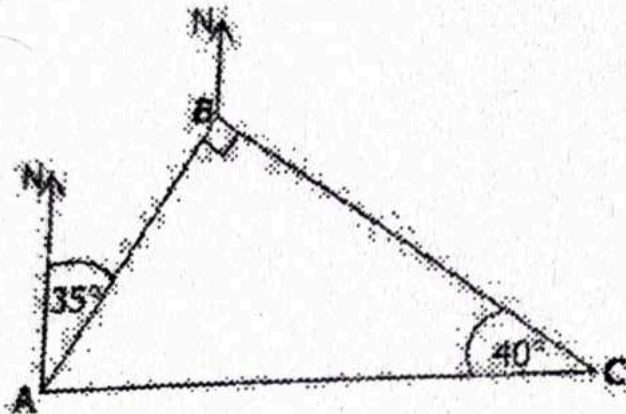

- Find the bearing of  
 (a) A from C  
 (b) A from B

www.eczpastpapers.com

Answer: (a).....[2]

(b).....[2]

- 15 Given that  $f(x) = \frac{3x-5}{2}$  and  $g(x) = x + 2$ , find  
 (a)  $f^{-1}(x)$   
 (b)  $f^{-1}(5)$   
 (c)  $fg(x)$

Answer: (a).....[1]

(b).....[1]

(c).....[2]

- 16 In the diagram, A, B, C and D are points on the circumference of a circle with centre O.  $BD=AD$  and  $\widehat{ADB}=40^\circ$

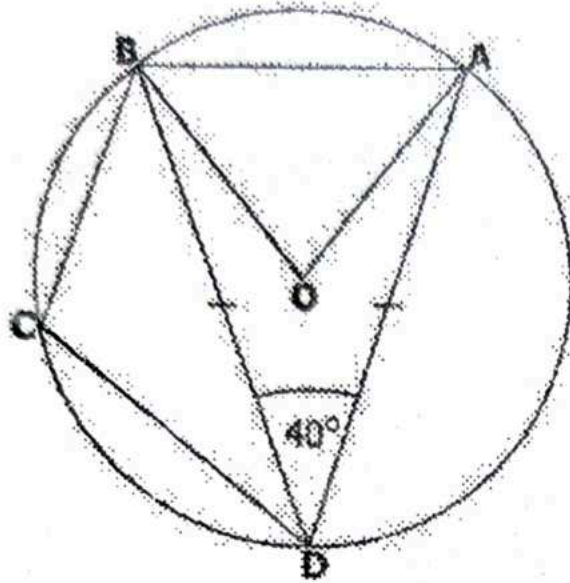

Find

- (a)  $\angle AOB$
- (b)  $\angle BCD$
- (c)  $\angle OBD$

[www.eczpastpapers.com](http://www.eczpastpapers.com)

Answer: (a).....[1]

(b).....[1]

(c).....[2]

- 17 (a) The diagram shows triangles P and Q.

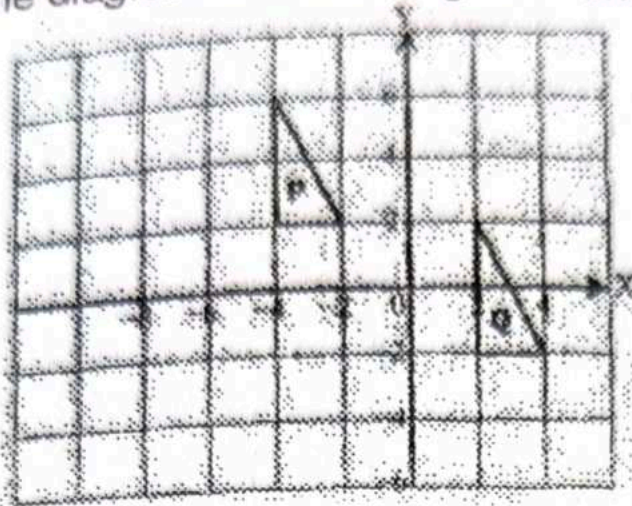

Describe fully the single transformation which maps triangle P onto triangle Q.

- (b) In the answer space below is an incomplete flowchart for calculating the volume ( $V$ ) of a cone. Given the radius ( $r$ ) and height ( $h$ ) of the cone, complete the flowchart.  $[V = \frac{1}{3}\pi r^2 h]$

www.eczpastpapers.com

Answer: (a) ..... [2]

(b)

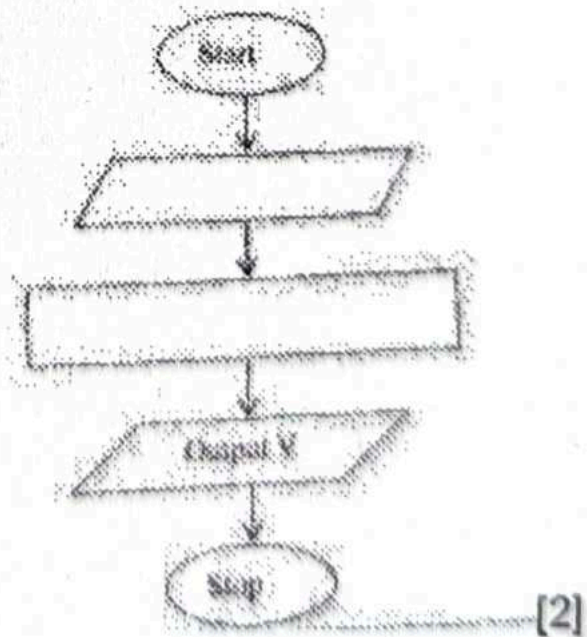

[2]

- 18 Z varies inversely as the square of  $x$  and directly as  $y$  and  $z = 6$  when  $x = -3$  and  $y = 27$ . Find the
- value of  $k$  the constant of variation
  - value of  $z$  when  $y = -6$  and  $x = -2$
  - values of  $x$  when  $y = 8$  and  $z = 1$

Answer: (a).....[1]

(b).....[1]

(c).....[2]

- 19 (a) Paul invests K50 000.00 in a government bond at 9% simple interest per annum. How much will the bond be worth after 3 years?
- (b) Two cylindrical tins are geometrically similar. The radius of the base of the smaller tin is 6cm and that of the bigger tin is 9cm. Given that the volume of the bigger tin is  $108\text{cm}^3$ , find the volume of the smaller tin.

Answer: (a).....[2]

(b).....[2]

- 20 (a) The diagram shows a right angled triangle ABC. BC is produced to D.  $AC = 13\text{cm}$  and  $\cos BAC = \frac{12}{13}$ .

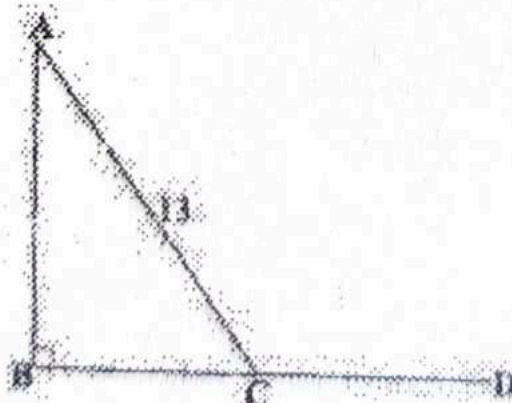

Find the value of  $\tan ACD$

(b) Find the equation of a straight line passing through the point  $(-2,3)$  and is parallel to the straight line whose equation is  $2y - 3x = 5$ .

Answer: (a) ..... [2]

(b) ..... [2]

21 Write three inequalities that define the unshaded region R in the diagram below.

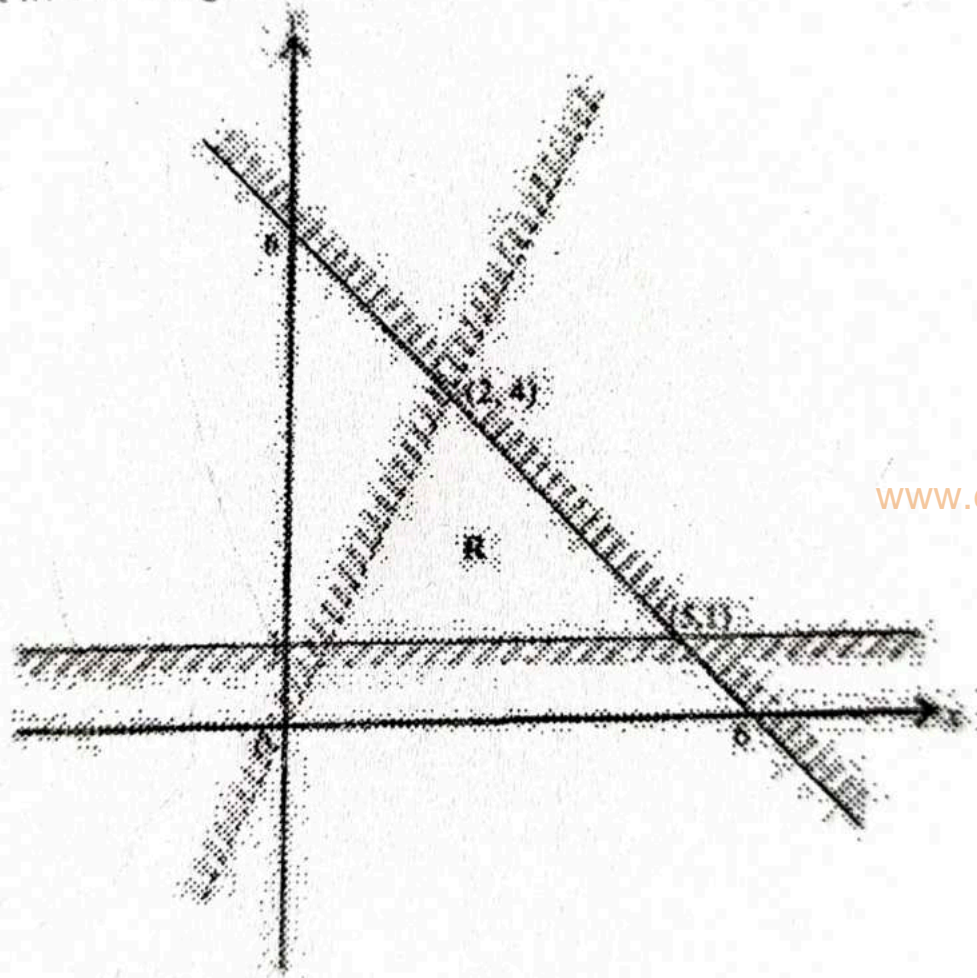

www.eczpastpapers.com

Answer: .....

.....

..... [5]

- 22 (a) Integrate  $3x^2 - 5x + \frac{9}{x^3}$  with respect to  $x$ .
- (b) The diagram shows the graph of the function  $y = x^2 + 2x - 15$ . The curve cuts the  $x$ -axis at A and B and the  $y$ -axis at C.

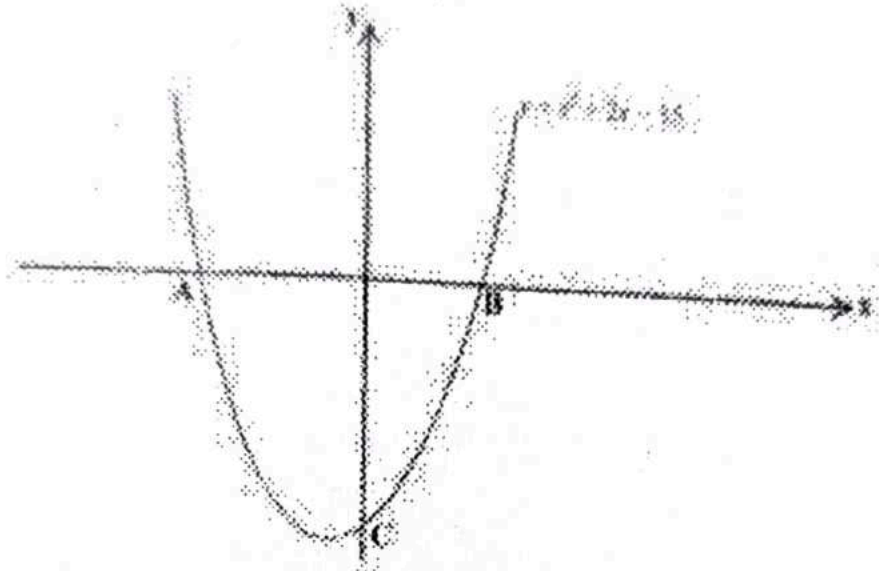

Find the

- (i) coordinates of B and C  
(ii) minimum value of  $y$

[www.eczpastpapers.com](http://www.eczpastpapers.com)

Answer: (a) ..... [2]  
(b) (i) ..... [2]  
(ii) ..... [2]

- 23 The following diagram is a speed-time graph of a car. The car starts from rest and accelerates uniformly at  $3\text{m/s}^2$  for 4 seconds until it reaches a speed of  $v$  m/s. It then travels at this constant speed for 8 seconds. It finally comes to rest after  $t$  seconds.

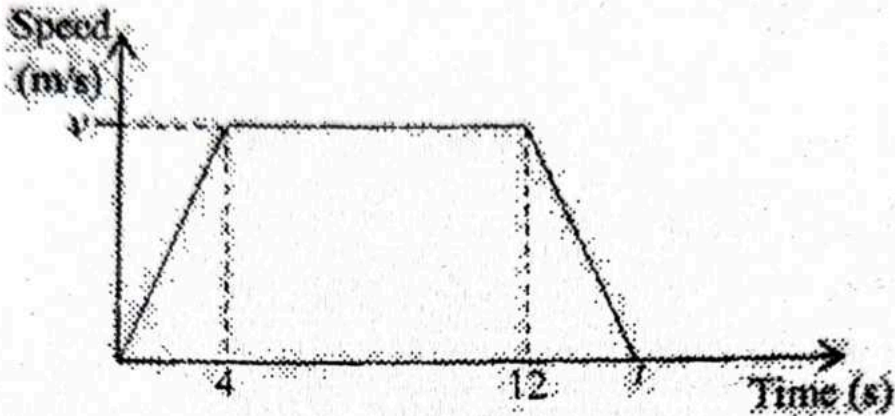

Find the

- value of  $v$ ,
- average speed for the first 12 seconds,
- value of  $t$ , if the speed at  $t = 14$  is  $4\text{m/s}$ .

www.eczpastpapers.com

Answer: (a).....[1]  
 (b).....[2]  
 (c).....[3]