

Candidate Name: _____

Centre Number		Candidate Number											

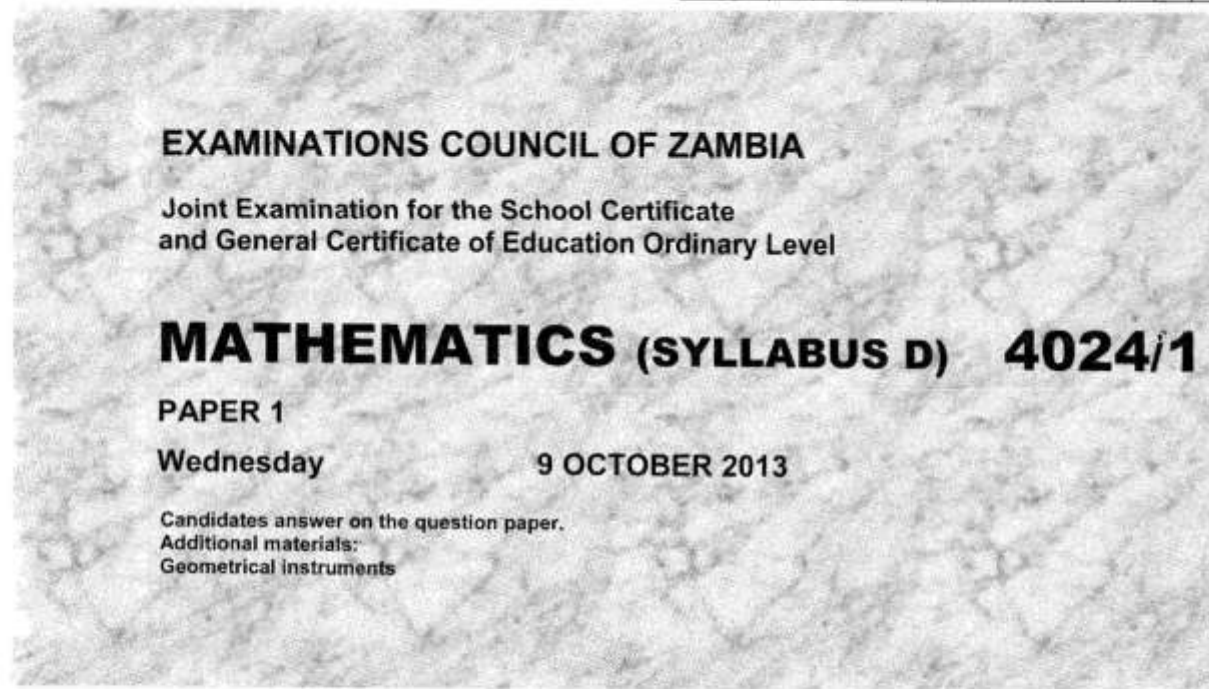

Time: 2 hours

INSTRUCTIONS TO CANDIDATES

Write your name, centre number and candidate number in the spaces provided at the top of this page.

There are **twenty-three** questions in this paper.

Answer **all** questions.

Write your answers in the spaces provided on the question paper.

If working is needed for any question, it must be shown in the space below that question.

No paper for rough work is to be provided.

Omission of essential working will result in loss of marks.

ELECTRONIC CALCULATORS AND MATHEMATICAL TABLES SHOULD NOT BE USED IN THIS PAPER.

CELL PHONES SHOULD NOT BE BROUGHT IN THE EXAMINATION ROOM.

INFORMATION FOR CANDIDATES

The number of marks is given in brackets [] at the end of each question or part question.

The total number of marks for this paper is 80.

FOR EXAMINER'S USE

--

1 Find the exact value of

(a) $2.025 + 42.1$,

(b) $\frac{2}{3} \div \frac{4}{5}$.

Answer: (a)..... [1]

(b)..... [1]

2 Express 50cm as a percentage of 2m.

Answer: [2]

3 Express 0.002304 in standard form, correct to one decimal place.

Answer: [2]

4 Evaluate

(a) $42 - 8 \div 2 + 5,$

(b) $\left(\frac{3}{4}\right)^{-2}.$

Answer: (a)..... [1]

(b)..... [1]

5 Use set notation to describe the shaded region in the diagram below.

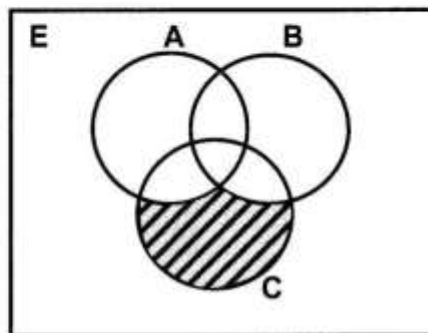

Answer: [2]

- 6 (a) 5 miles is approximately equal to 8km. What is the distance in miles between two towns which are 24km apart?
- (b) Madyelo bought 2kg of meat and 800g of kapenta. Express, as a ratio in its simplest form, the mass of meat to that of kapenta.

Answer: (a) [1]
(b) [1]

- 7 (a) Find the equation of the line joining the point A(0, 7) to the point B(7, 0).
- (b) Solve the inequality $3x > 4 - 2x$.

Answer: (a) [1]
(b) [1]

8 Solve the simultaneous equations

$$b = 6 - a,$$

$$2a + 3b = 13.$$

Answer: $a =$

$b =$ [3]

9 For the sequence 2, 5, 8, 11 . . . find

(a) the sixth term,

(b) an expression for the n^{th} term.

Answer: (a)..... [1]

(b)..... [2]

- 10 (a) How many subsets has the set $A = \{1\}$?
(b) In the diagram below, C is due East of A and due North of B. Angle BAC is 50° .

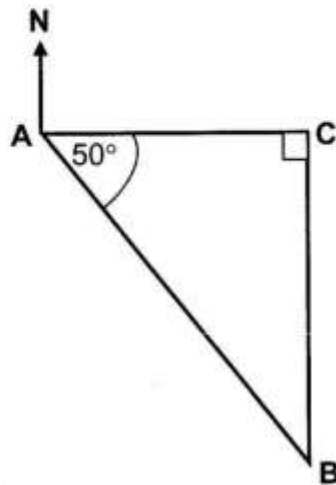

Find the bearing of A from B.

Answer: (a) [1]
(b) [2]

-
- 11 (a) Given that $\vec{AB} = \begin{pmatrix} 1 \\ -3 \end{pmatrix}$ and B is the point (4, 5), find the coordinates of A.
(b) Factorise completely $3ap - 8bq - 4aq + 6bp$.

Answer: (a) [1]
(b) [2]

12 A function h is defined as $h(x) = \frac{1}{2}x - 5$.

Find

- (a) $h(-4)$,
- (b) the value of x for which $h(x) = 3$,
- (c) $h^{-1}(x)$.

Answer: (a) [1]

(b) [1]

(c) [2]

13 (a) The diagram below shows a cylinder of height 9cm and diameter 7cm.

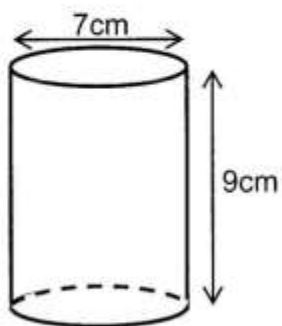

Calculate the curved surface area of the cylinder [Take π to be $\frac{22}{7}$].

(b) Solve the equation $(x - 1)(x + 1) = 8$.

Answer: (a) [2]

(b) $x =$ or [2]

- 14 (a) The results of a survey conducted at Kansapato Community School on the shoe sizes of 89 pupils are shown in the table below.

Shoe size	33	34	35	36	37	38	39	40
Number of pupils	5	12	10	16	15	17	9	5

Find

- (i) the modal shoe size,
 - (ii) the median shoe size.
- (b) In the diagram below, triangle A is mapped onto triangle B by a single transformation. Describe fully the transformation.

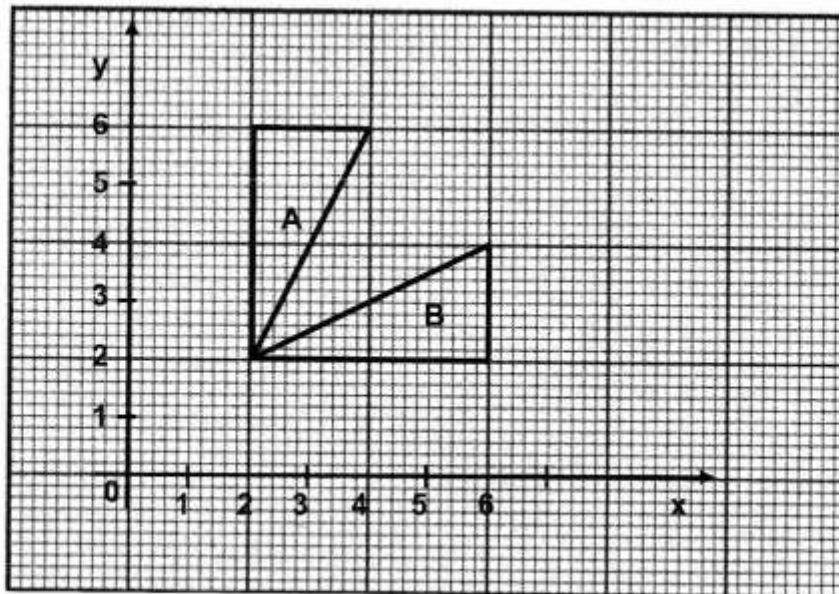

Answer: (a) (i)[1]

(ii)[1]

(b)

..... [2]

- 15 (a) A survey conducted in a certain village revealed that one out of every five boys drank chibwantu. If there were 215 boys in that village, how many drank chibwantu?
- (b) Bonzo is a town on $(53^{\circ}\text{S}, 65^{\circ}\text{W})$ and Munyefu is another town on $(53^{\circ}\text{S}, 19^{\circ}\text{E})$. A football match is scheduled to kick off at 15 30 hours local time at Bonzo. What will be the kick off time at Munyefu?

Answer: (a) [1]

(b)

..... [3]

- 16 A circle centre O passes through the points A, B, C, and D as shown in the diagram below. Angle $\text{AOC} = 110^\circ$ and AO is parallel to BC.

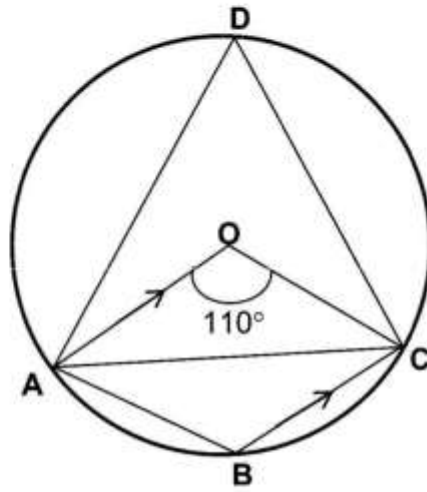

- Find
- (a) $\hat{\text{OCA}}$,
 - (b) $\hat{\text{ACB}}$,
 - (c) $\hat{\text{ABC}}$.

Answer: (a) [1]
 (b) [1]
 (c) [2]

17 (a) Given that $m = \frac{2my - 5x}{2}$, express x in terms of m and y .

(b) Kaponya got a simple interest of K375.00 from a bank after investing a sum of money for 18 months. Find the amount of money he invested, if the bank interest rate was 10% per annum.

Answer: (a) [2]

(b) [2]

18 (a) Each interior angle of a regular polygon is 17 times the size of the exterior angle. Find the size of each exterior angle.

(b) Given that the matrix $\begin{pmatrix} 3x & 2 \\ 1 & 4 \end{pmatrix}$ is singular, calculate the value of x .

Answer: (a) [2]

(b) [2]

- 19 Given that y varies directly as x and inversely as $2m - 1$ and that $y = 5$ when $x = 7$ and $m = 4$, calculate
- the constant of variation, k ,
 - the value of y when $x = 2$ and $m = 3$,
 - the value of m when $y = 2$ and $x = 4$.

Answer: (a) [1]
 (b) [1]
 (c) [2]

- 20 (a) A 10m ladder rests against a vertical wall with its foot 6m from the wall. How far up the wall does the ladder reach?
- Simplify $2x - 9 + 3x^2 - 2 - 4x$.
 - A road between two villages A and B is 1.2km long. It is represented by 3cm on the map. Calculate the scale of the map, in the form 1:n.

Answer: (a) [1]
 (b) [2]
 (c) [2]

21 In the diagram below, R is the unshaded region.

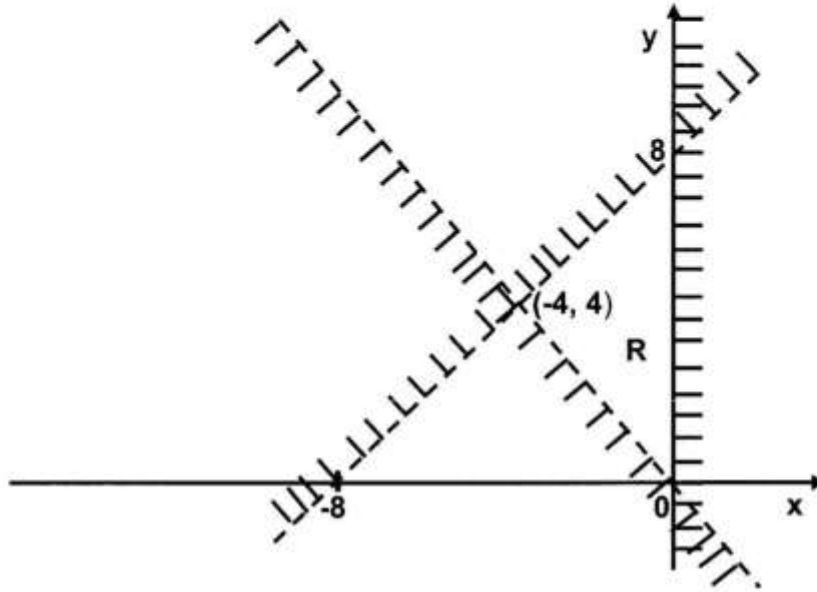

Write three inequalities which describe the region R.

Answer:
..... [5]

- 22 (a) Two containers are geometrically similar. The ratio of their base areas is 9:16. If the volume of the smaller container is 135m^3 , what would be the volume of the larger container?
- (b) In the diagram below, ABC is a straight line, $BC = 8\text{cm}$, $BD = 10\text{cm}$ and $\sin \hat{ABD} = \frac{3}{5}$.

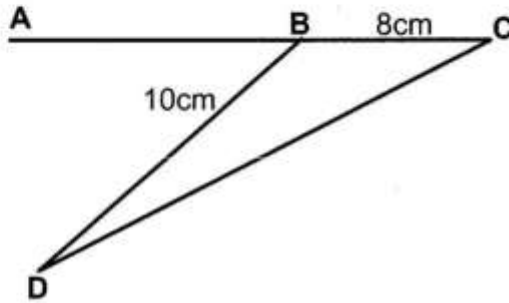

Find the area of triangle BCD.

- (c) On the diagram in the answer space, shade two more squares so that the figure has two lines of symmetry.

Answer: (a) [2]

(b) [2]

(c)

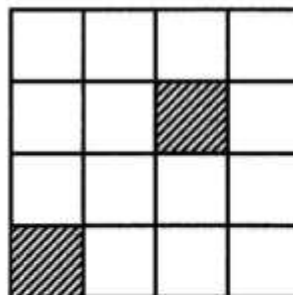

[2]

- 23 Two towns Katulya and Twasika are 50km apart. Kachova started off from Twasika for Katulya at the same time as Namutekenya from Katulya to Twasika as shown in the Distance – Time graph.

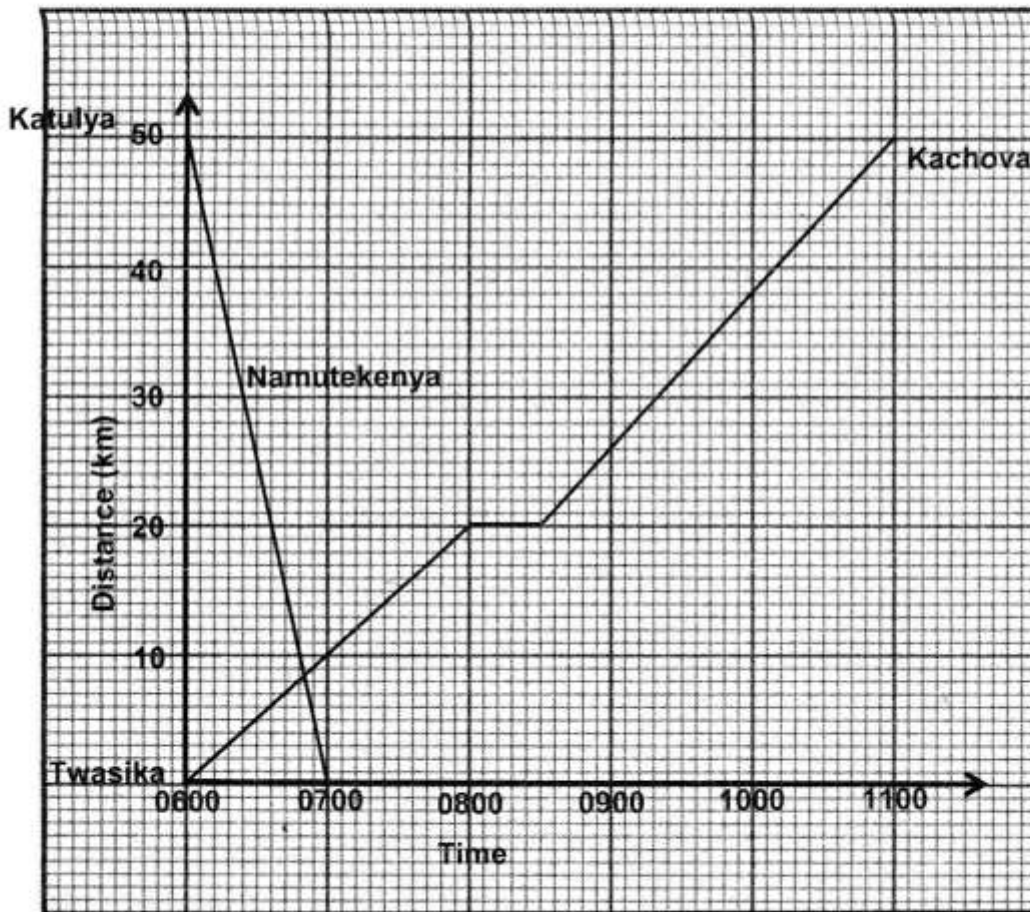

- How far was Kachova from arriving at Katulya when Namutekenya reached Twasika?
- How long had Namutekenya been in Twasika before Kachova restarted his trip after a short rest?
- Calculate the difference between the average speeds of Kachova and Namutekenya.

Answer: (a) [2]
 (b) [2]
 (c) [2]