

Using a Network Simulation Tool

Lecture 7

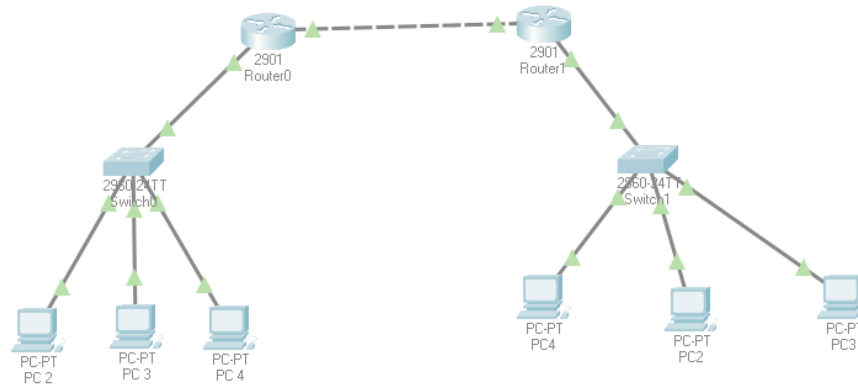

Phyela Mbewe
LIS Department
University of Zambia

Network Simulators



- Network Simulation

- The use of software which can replicate the design and performance of a network
 - this includes analyzing the connections of various network entities such as switches, routers, servers etc.
 - a software that can replicate the design and performance of a network is known as a **network simulator**

Network Simulators



- Advantages of a network simulator:
 - Allows a user to design and plan the physical and logical connections of a network before the network is implemented
 - A network simulator can provide feedback to the user concerning the design of the network,
 - the user can correct errors (or make improvements) in the design stage of a network before implementing certain errors in a real network environment
 - Network simulators are useful in teaching and demonstrating network concepts to others

Network Simulators

- Common Network Simulation Tools
 - GSN3
 - Cisco Packet Tracer
 - PRTG Network Monitor
 - Network Simulator (NS3)
 - Boson Network Simulator
 - Virtual Internet Routing Lab (VIRL)

Note: there are more network simulators, the list above is some of the common network simulators

Note 2: our focus will be on using **Cisco Packet Tracer** for network simulation

Network Simulators

- Cisco Packet Tracer
 - Packet Tracer is a program used to replicate networks for learning and network designing purposes
 - it is a network simulator designed and maintained by Cisco Systems, it is intended to be used for learning purposes primarily

Note: we will be utilizing **Cisco Packet Tracer** to demonstrate designing a network within ICT 4010. It is recommended that you download Packet Tracer and are familiar with the steps for designing a simple network in Packet Tracer



Packet Tracer - Installation

- **Download Packet Tracer from Cisco / NetAcad**
- **Download Links:**
 - Windows 64bit**
 - <https://www.netacad.com/portal/resources/file/ac467cce-d070-48a5-928c-81caf6142681>
 - (roughly 160 MB file download)
 - Windows 32bit**
 - <https://www.netacad.com/portal/resources/file/de238ba8-38e0-4b7e-b612-a6ca35df3118>

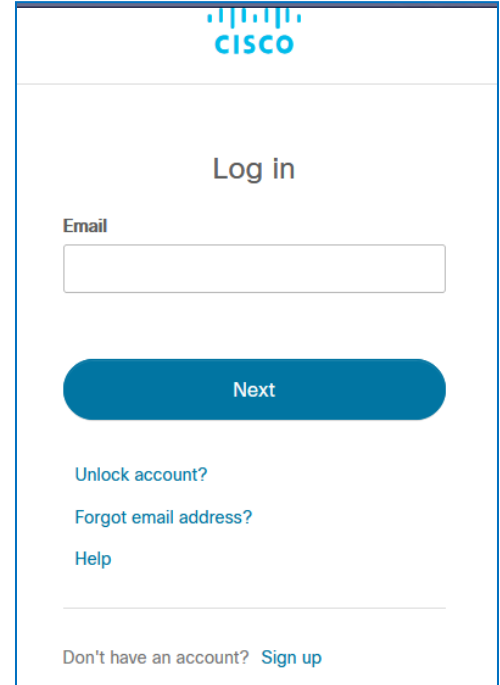

The screenshot shows the Cisco login interface. At the top is the Cisco logo. Below it is the text "Log in". There is an "Email" label above a text input field. Below the input field is a large blue button labeled "Next". Underneath the button are three links: "Unlock account?", "Forgot email address?", and "Help". At the bottom of the page, there is a link that says "Don't have an account? Sign up".

Note: you may be required to log into a Cisco account before packet tracer can be used (the links above may redirect to a login page, **Log in** with a Cisco account or select **Sign Up** to create a Cisco account)



Packet Tracer - Installation

- **Download Packet Tracer from Cisco / NetAcad (cont.)**

- Download Links:

- **Ubunut 64bit**

- <https://www.netacad.com/portal/resources/file/21267e14-5837-47a3-8819-39b65a958d15>

- **MacOS 64bit**

- <https://www.netacad.com/portal/resources/file/261dc7b6-1036-4867-bcc6-fe4f47ec7660>

CISCO

Log in

Email

Next

[Unlock account?](#)

[Forgot email address?](#)

[Help](#)

Note: Cisco may undergo a **verification process** on a new user account before that account is fully activated, i.e.. a newly created user account may be useable immediately or may be usable after a verification has been completed



Packet Tracer Installation

After downloading the Packet Tracer Setup file

- **Run the Packet Tracer setup file to install packet tracer on your PC**
 - follow the default installation options for Packet Tracer

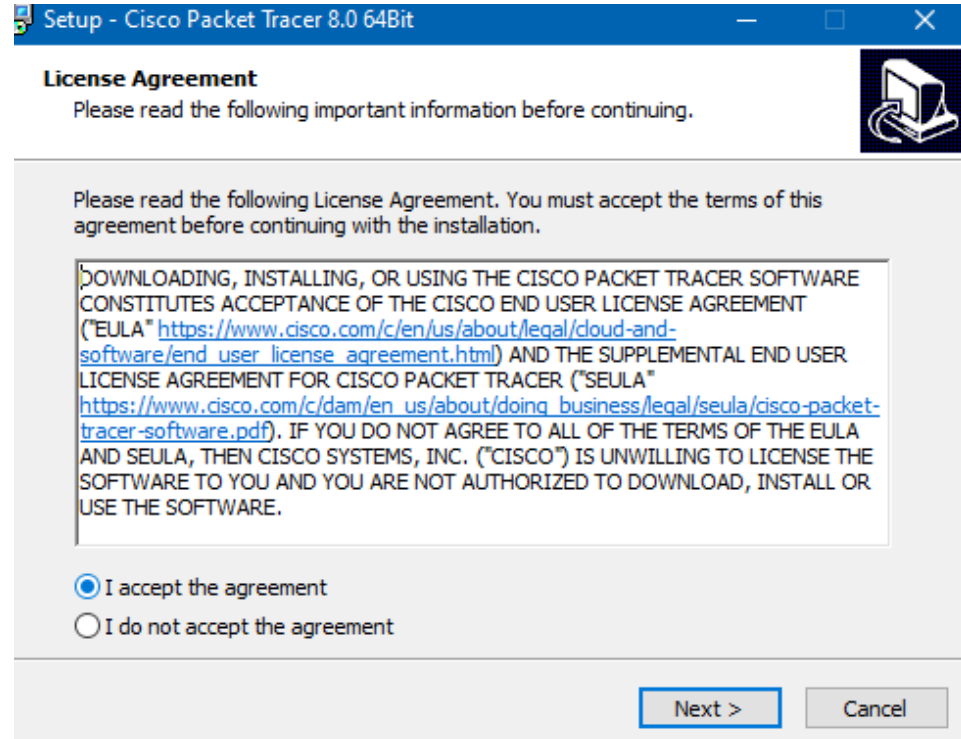



Packet Tracer Login

- *After installing Packet Tracer*
 - Run Packet Tracer from the Start Menu(Windows) or from the Desktop, etc.

- Note that Packet Tracer will require **logging into** a Cisco user account before the main workspace can be used

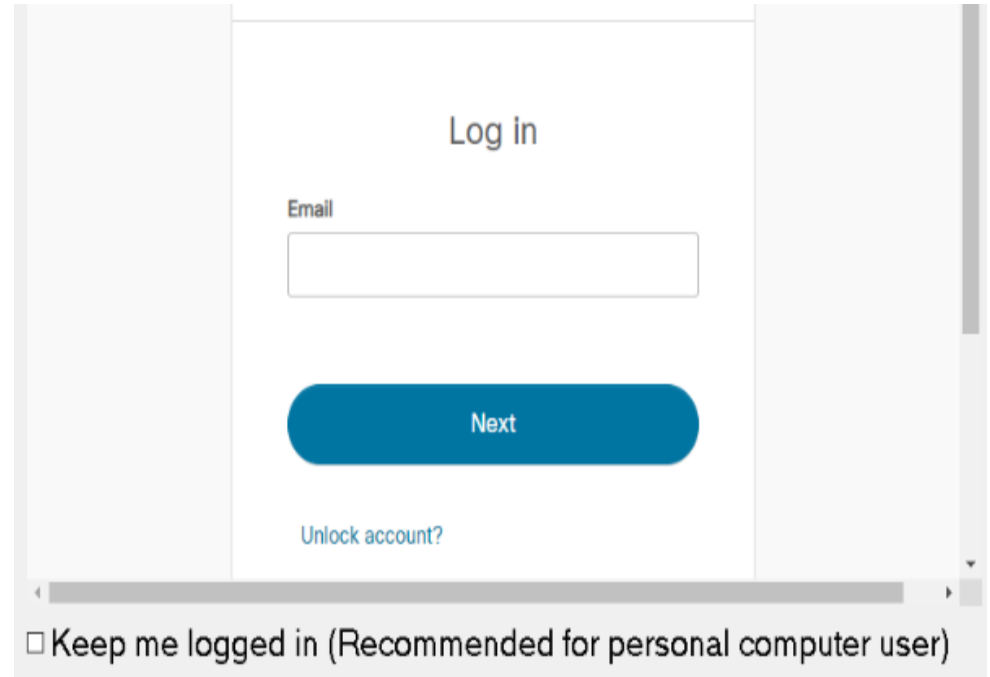
A screenshot of the Packet Tracer login interface. The title "Log in" is centered at the top. Below it is a text input field labeled "Email". Underneath the input field is a large, rounded blue button with the text "Next". At the bottom of the form, there is a link that says "Unlock account?". Below the main form area, there is a checkbox with the text "Keep me logged in (Recommended for personal computer user)".

Log in

Email

Next

Unlock account?

Keep me logged in (Recommended for personal computer user)



Packet Tracer Login

- *After installing and running Packet Tracer*
- Enter your Cisco user account details and login to use Packet Tracer
 - You can tick the **Keep me logged in** option before logging in (otherwise Packet Tracer will require logging in again the next time you open it, this option is suitable for personal computers)

Log in

Email

Next

[Unlock account?](#)

Keep me logged in (Recommended for personal computer user)



Packet Tracer Login

- *After installing and running Packet Tracer (cont.)*
- At the Packet Tracer login page, you can also choose **Sign Up** to create a Cisco user account
- You can choose **Continue as a Guest**
 - However a guest user is limited in the number of times that Cisco project files can be saved.
 - recommendation is to sign up and log in with a Cisco user account
 - A guest account can be used if there is a problem with logging in (problems with signing up, Cisco verification process etc.)

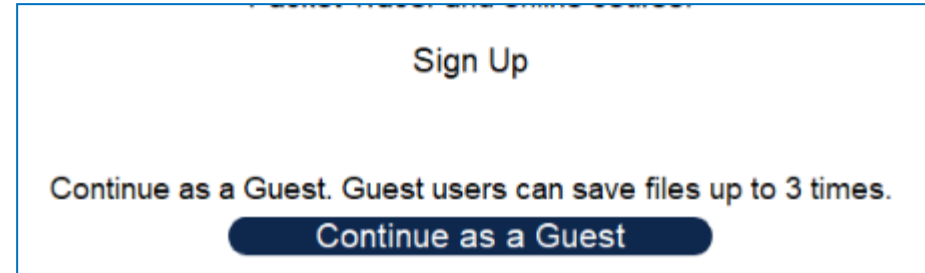



Packet Tracer Login

- *After installing and running Packet Tracer (cont.)*
- Note that you may have to click **Allow access** on your Windows Firewall...
- ...the first time that Packet Tracer is launched

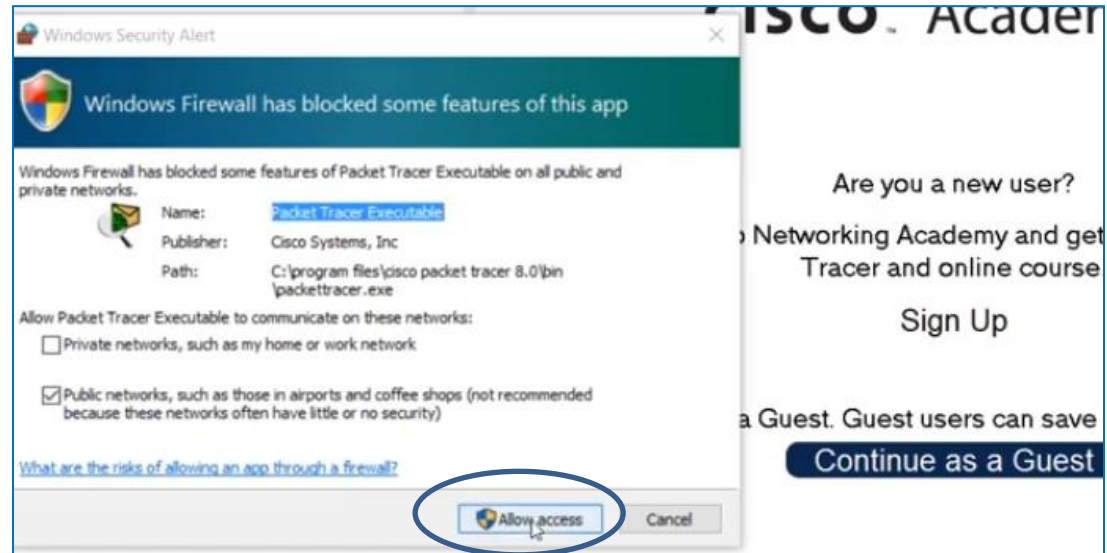



Packet Tracer Login – Error Message

- After logging into Packet Tracer *for the first time* with a Cisco account
- An error message may occur regarding your Cisco account not being linked with a NetAcad account (depicted below)

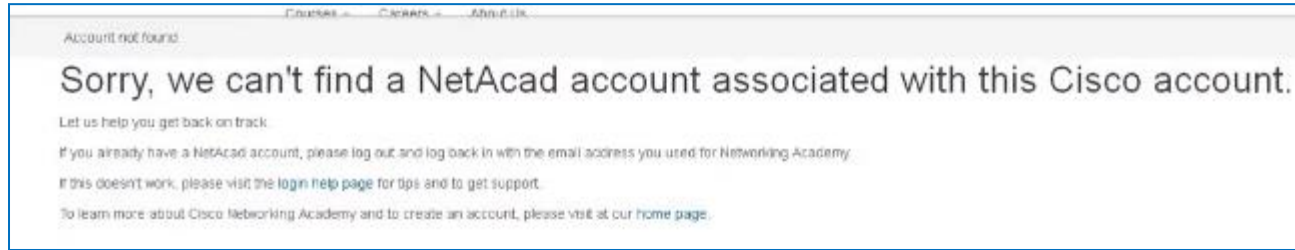

- **Both** a **Cisco** account and a **NetAcad** account (*which are associated*) are required to use Packet Tracer, there are different ways of achieving associated Cisco and NetAcad accounts, however a **verified Cisco account** will be required first

Packet Tracer Login – Cisco and NetAcad accounts

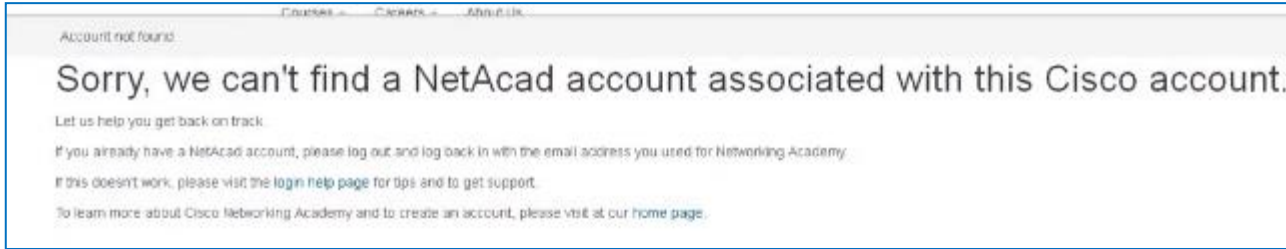

- ❖ **Setting up a NetAcad account. To resolve the (above) error: login into your Cisco account through a browser**
 - https://www.cisco.com/c/login/index.html?referer=/c/en_uk/index.html
- ❖ **Close and reopen Packet Tracer and select **Continue as a Guest** at the login page**
 - This will open a **NetAcad web page in your browser**

Packet Tracer Login – Cisco and NetAcad accounts



- ❖ Scroll down on the NetAcad web page and select **Sign up today** then select **English**

Required:

You'll Learn These Core Skills:

- Simulate data interactions traveling through a network.
- Visualize the network in both logical and physical modes.
- Apply skills through practice, using labs and Cisco Packet Tracer activities.
- Develop critical thinking and problem-solving skills.

[Sign up today!](#)

Note: you will have to enroll in at least one NetAcad online course in order to create a NetAcad account however, NetAcad offers a **free** Introduction to Packet Tracer course (along with other free courses)

Packet Tracer Login – Cisco and NetAcad accounts



After selecting **Sign up today** on the NetAcad webpage

❖ You will be redirected to the enrolment page of a free online course

❖ Fill in enrolment details (such as email address etc.) and then select **Create Account**

❖ Your NetAcad account will now be created

• Make sure to use the same email address that was used for your **Cisco** account

Introduction to Packet Tracer
English 1021a

Cisco Virtual Academy

-acm-
01 Oct 2021 - 31 Jan 2022
Jackson Smith

Enroll now

Email *

Packet Tracer Login – Cisco and NetAcad accounts



*After creating a **NetAcad account** through a free course*

- ❖ Activate your account through a link that will be sent to your email address

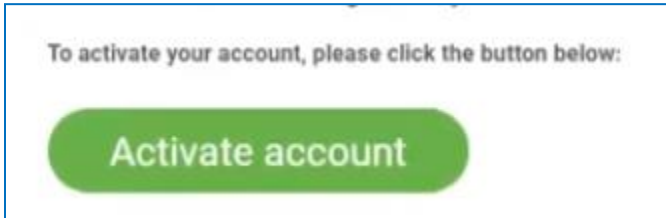
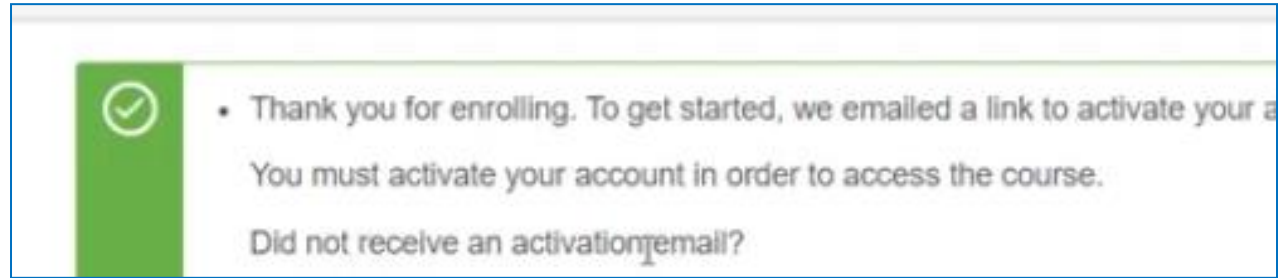

Go to your email address and click the Link sent via email

Packet Tracer Login – Cisco and NetAcad accounts



After clicking the **NetAcad activation** link (via email)

- ❖ You will be taken to a NetAcad web page that requires that you enter more details about yourself
 - ❖ (such as first name last name, birthday etc.)

We're excited to have you as part of Networking Academy. Learning more about you helps help people around the world. So tell us a little about you.

NetAcad webpage sample paragraph

- ❖ Fill in your NetAcad details and click **Create Account**

The 2nd time a NetAcad *Create Account* option is selected

Packet Tracer Login – Cisco and NetAcad accounts



*After clicking the **Create Account** (a second time, for a NetAcad account)*

- ❖ **Your NetAcad account sign up is complete** ✓
- ❖ You also have access to a free course (however you can ignore it, click the X, as indicated below)



You can access your free course in your own time via your NetAcad course*

Packet Tracer Login – Cisco and NetAcad accounts

- Now with a **verified Cisco account** and an **activated NetAcad account** (*which are associated and using the same email address*) you may log into Packet Tracer with you Cisco account. 
- The Packet Tracer workspace will be displayed upon successful login

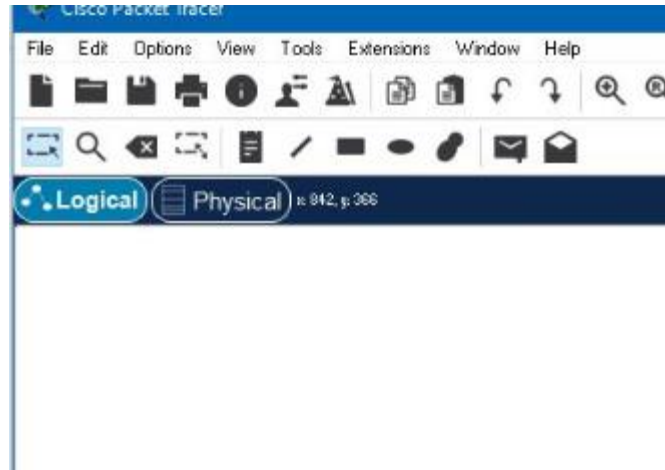

Packet Tracer Workspace

The screenshot displays the Cisco Packet Tracer workspace with the following numbered callouts:

- 1**: File menu
- 2**: Search icon
- 3**: Navigation icons (Home, Back, Forward, Refresh)
- 4**: Logical/Physical tabs and coordinate display (x: 535, y: 71)
- 5**: Main workspace area
- 6**: Time display (Time: 03:57:10) and Realtime/Simulation mode buttons
- 7**: Device selection toolbar
- 8**: Device list (4331, 4321, 1941, 2901, 2911, 8191OX, 8191HW, 829, 1240, PT-Router, PT-Empty, 184)
- 9**: Filter and Level/Element (Lev ele) buttons



Packet Tracer Workspace

1 - Menu Bar

- This bar provides the File, Options, and Help menus
- Provides basic commands such as Open, Save, Print, and Preferences in these menus

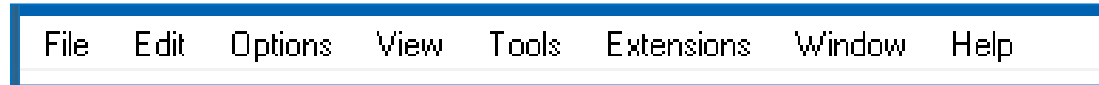

2- Main Tool Bar

- This bar provides shortcut icons to the File menu commands, and other shortcut icons.





Packet Tracer Workspace

- **3 - Common Tools Bar**
- This bar provides access to the following commonly used workspace tools
 - Select
 - Move Layout
 - Place Note
 - Delete
 - Inspect
 - Add Simple PDU
 - Add Complex PDU





Packet Tracer Workspace

4 - Workspace Type Bar

- Provides the option to toggle between the Physical Workspace and the Logical Workspace modes

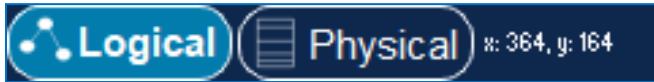



Packet Tracer Workspace

5 - Workspace

- This is the main area where a user will create networks, watch simulations, and view various information and statistics

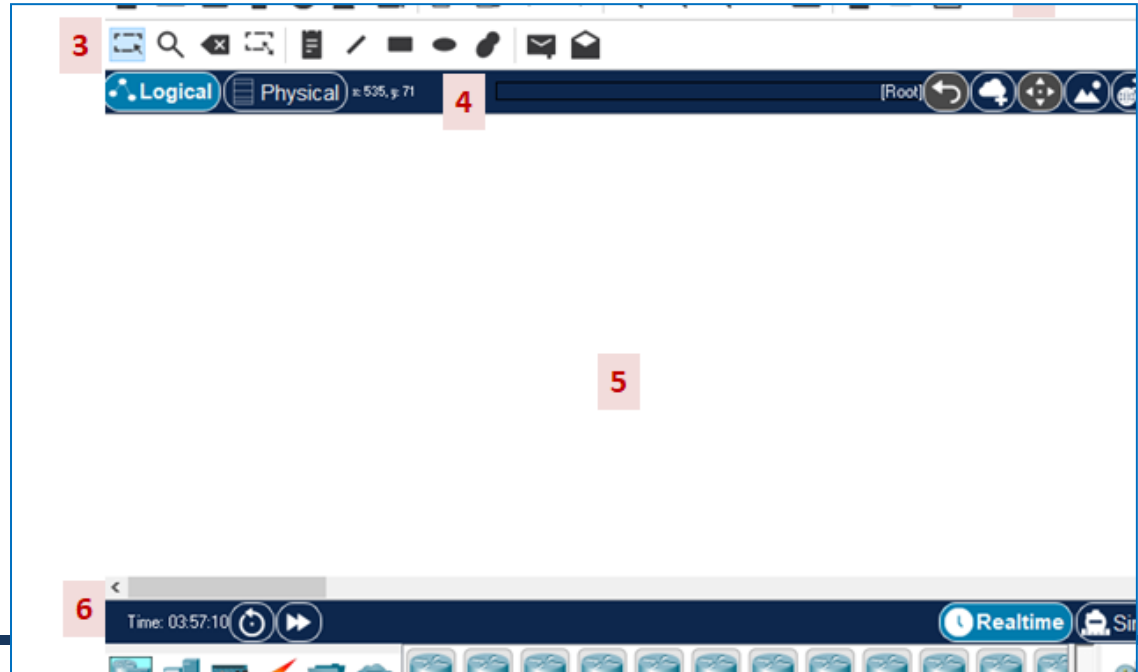



Packet Tracer Workspace

6 - Realtime or Simulation Bar

- You can toggle between Realtime Mode and Simulation Mode with the tabs on this bar





Packet Tracer Workspace

7 - Device Type Selection Box

- This box contains the various devices and connections available in Packet Tracer

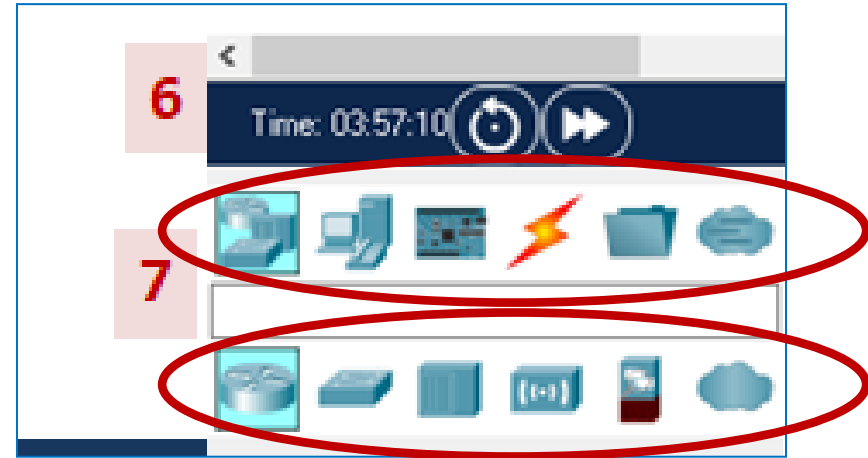

Note that a selection made in the device categories (top) will determine the device types displayed (bottom)



Packet Tracer Workspace

- **8 - Device Specific Selection Box**
- This box is where you choose specifically which devices you want to put in your network and which connections to make
- The Device-Specific Selection Box will change depending on which device type selected (from the **Device Type Selection Box**)





Packet Tracer Workspace

9 - Created Packet Window

- This window manages the packets you put in the network during simulation scenarios
 - Can indicate if a packet sent has been transmitted successfully or not

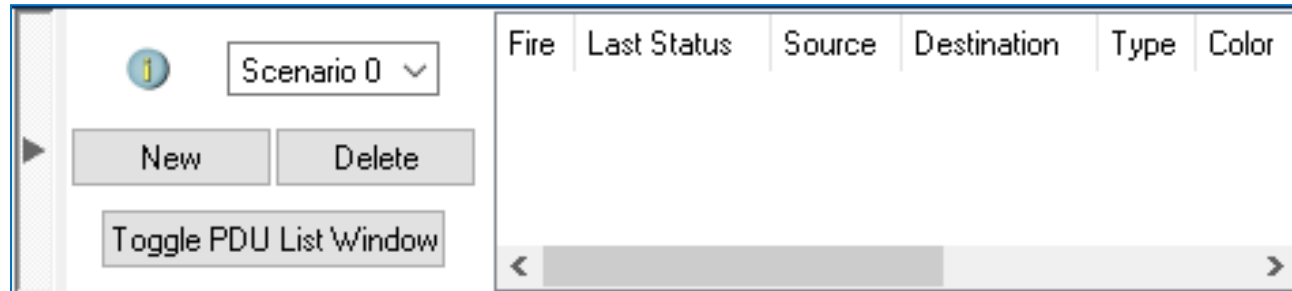



Creating A Simple Network

The following slides will indicate some of functionality in Packet Tracer with the goal of designing a **simple network** of devices in a Local Area Network (LAN)

- *By default (when a new packet tracer project is started) the Workspace displayed will be a **Logical Workspace***
- **Logical Workspace:**
 - allows users to build logical network topologies by placing, connecting and configuring virtual network devices in the workspace

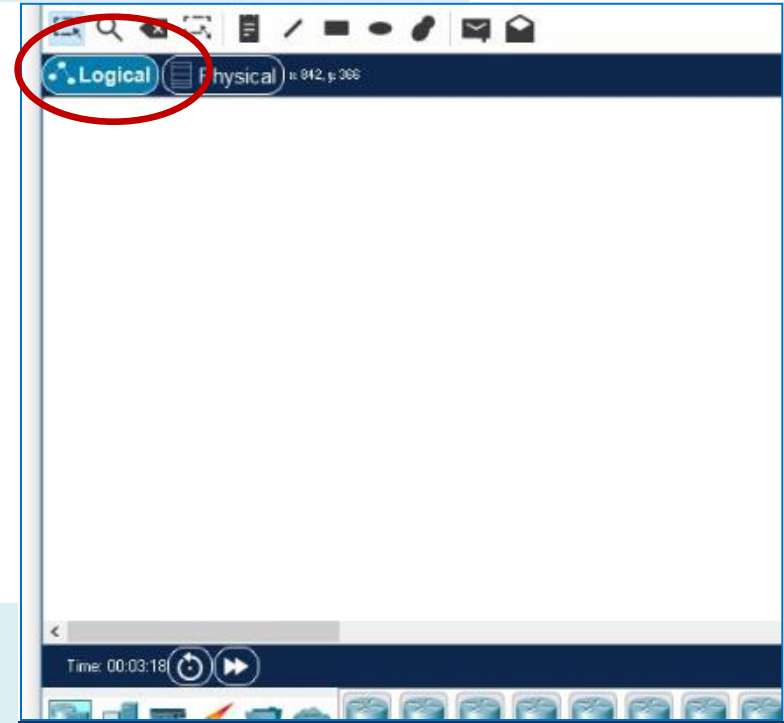

Note: there will be a *presented demonstration* which shows designing a simple network in Packet Tracer (and will match with the information in the following slides)



Creating A Simple Network

- **Physical Workspace:**
 - The physical workspace provides **geographic representations** of networks, including designing networks for multiple cities and buildings.



Note: our focus will be on using the Logical Workspace to create a basic LAN



Creating A Simple Network

Placing a **network device (PC)** in the workspace

- Within the **Logical Workspace**:
- Network devices can be added into the workspace using the **Device Type Selection Box (a and b)** and the **Device Specific Selection Box (c)**.

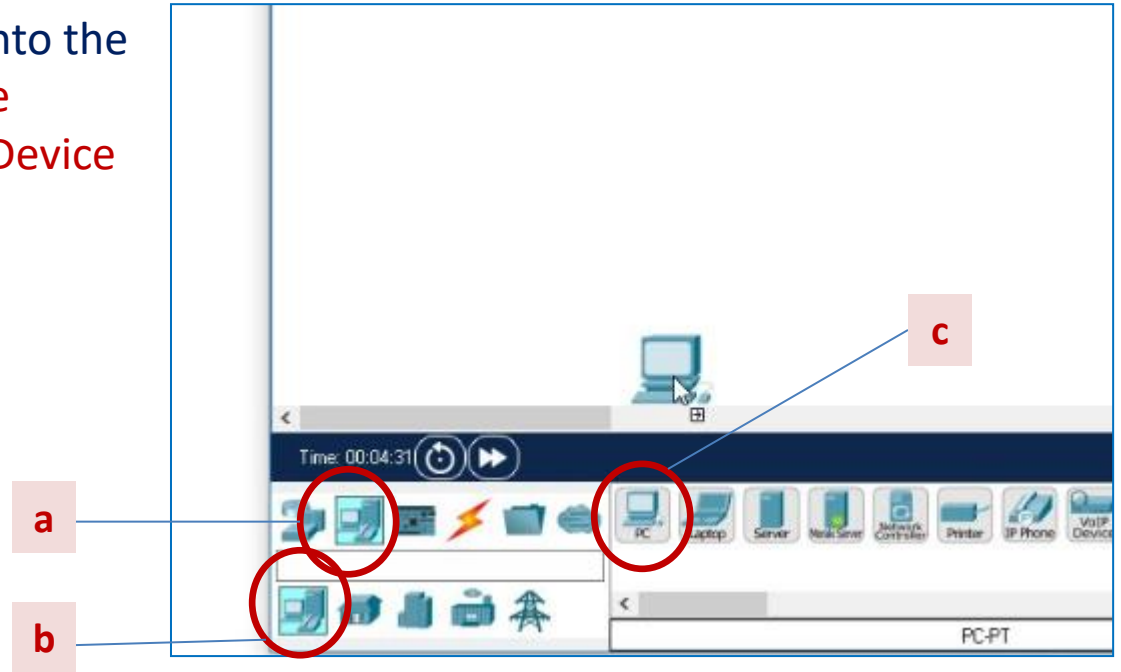



Creating A Simple Network

Placing a PC in the workspace

- a) Select the **End Devices** device category
- b) select the **End Devices** device type
- c) left-click on the **PC** specific device and then left-click within the **workspace** to add a PC to the workspace

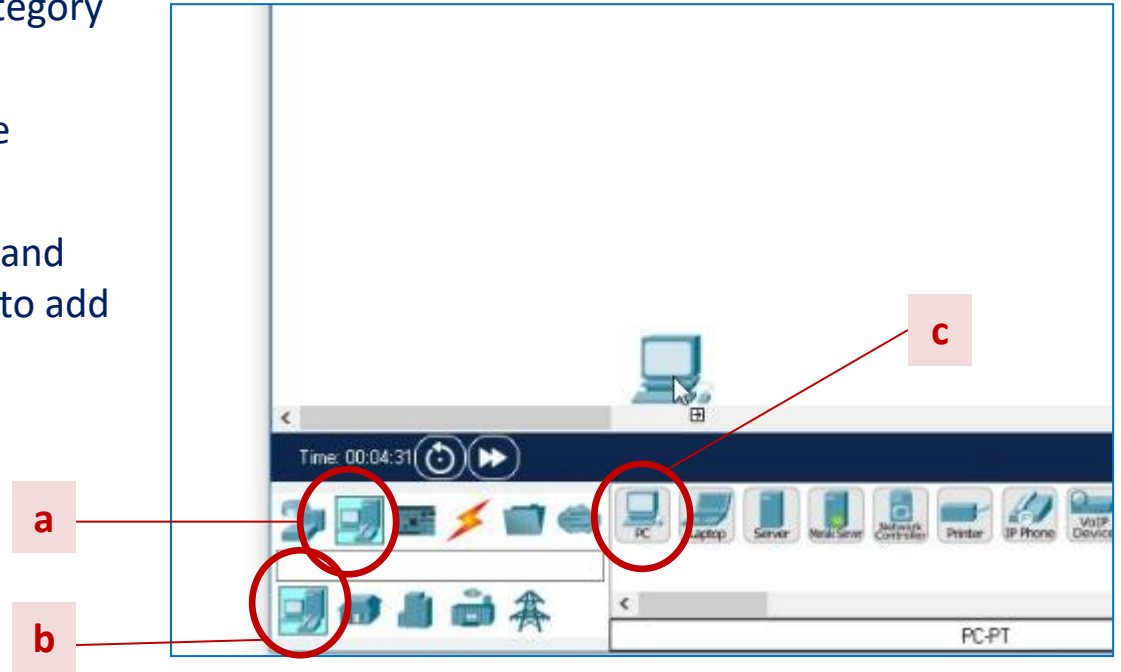



Creating A Simple Network

Placing **another PC** in the workspace

- left-click on the **PC** specific device and then left-click within the **workspace** to add another PC to the workspace
- Repeat this step to add roughly four PCs to the workspace
- *Note: you can also drag a PC from the device specific selection box into the workspace (this can be done for the other devices as well)*

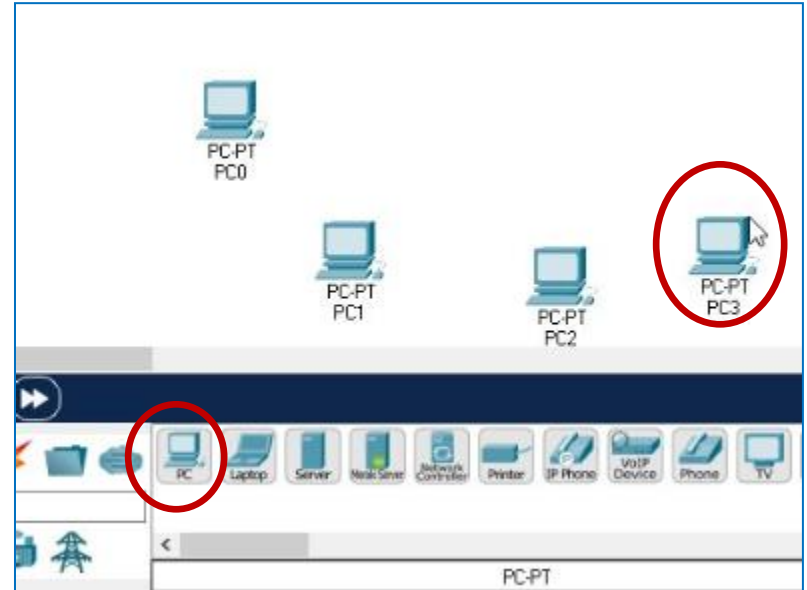



Creating A Simple Network

Placing a Router in the workspace

- a) Select the **Network Devices** device category
- b) select the **Routers** device type
- c) drag and drop a **2911 Router** specific device from the device specific selection box into the workspace

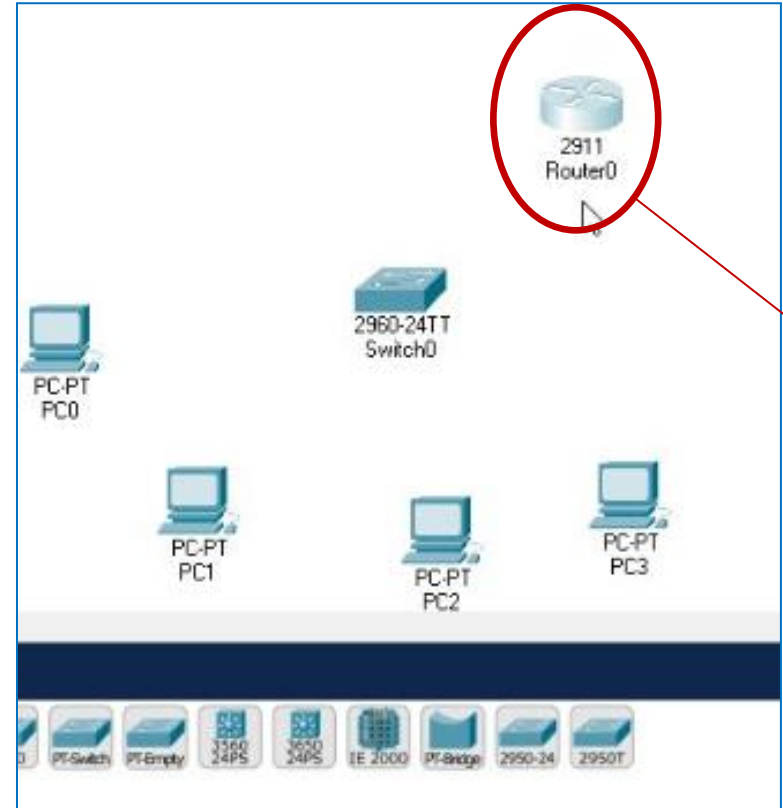

Note: a basic LAN can be created by connecting PCs to a Switch (without a Router), *however we will add a Router now for connecting two LANs together later*



Creating A Simple Network

Viewing device properties for a PC

- Left-click on a PC in the workspace
 - This will bring a device properties window which has options to change the hardware modules and change the settings of a PC

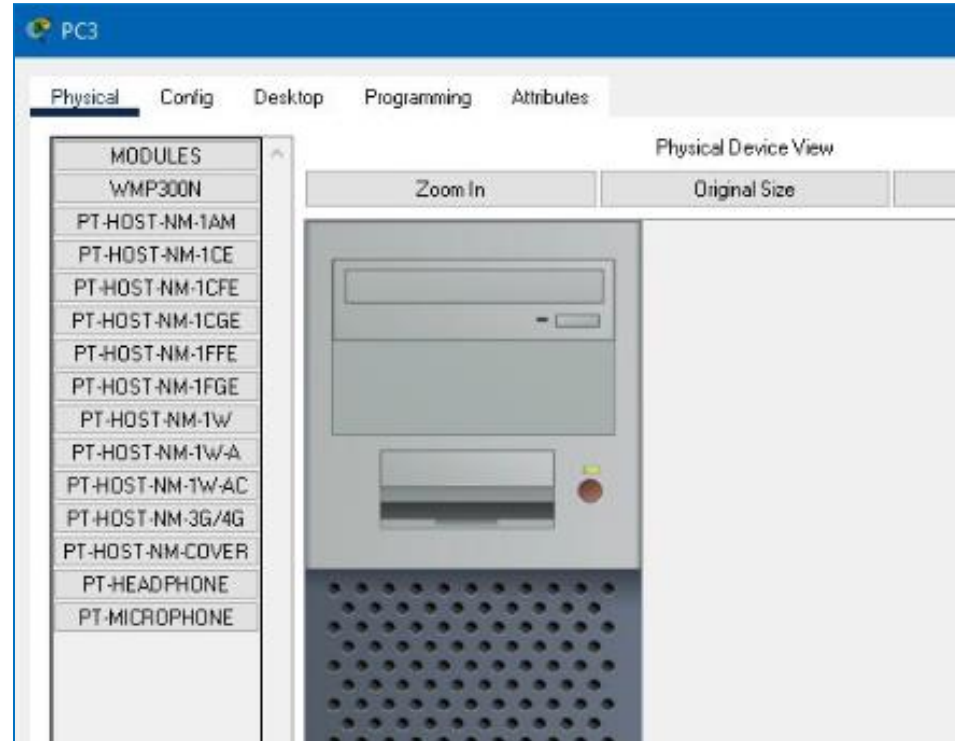



Creating A Simple Network

Viewing device properties for a Switch

- Left-click on the Switch in the workspace
 - This will bring a device properties window for the Switch

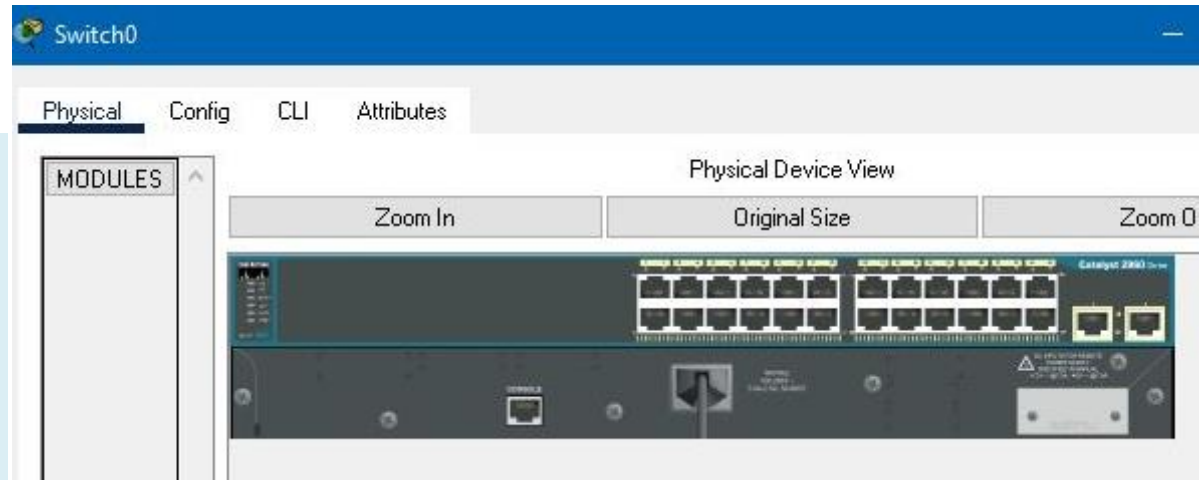

Note: we will change the IP settings for the PCs (and the router), the Switch settings will be left to their defaults. The Switch will mainly be used to connect multiple PCs together



Creating A Simple Network

Viewing device properties for a Router

- Left-click on the Router in the workspace
 - This will bring the device properties window for the Router
 - The device properties window will have various tabs, however, the **Physical** tab will be displayed first when opening device properties for a PC, Switch or a Router

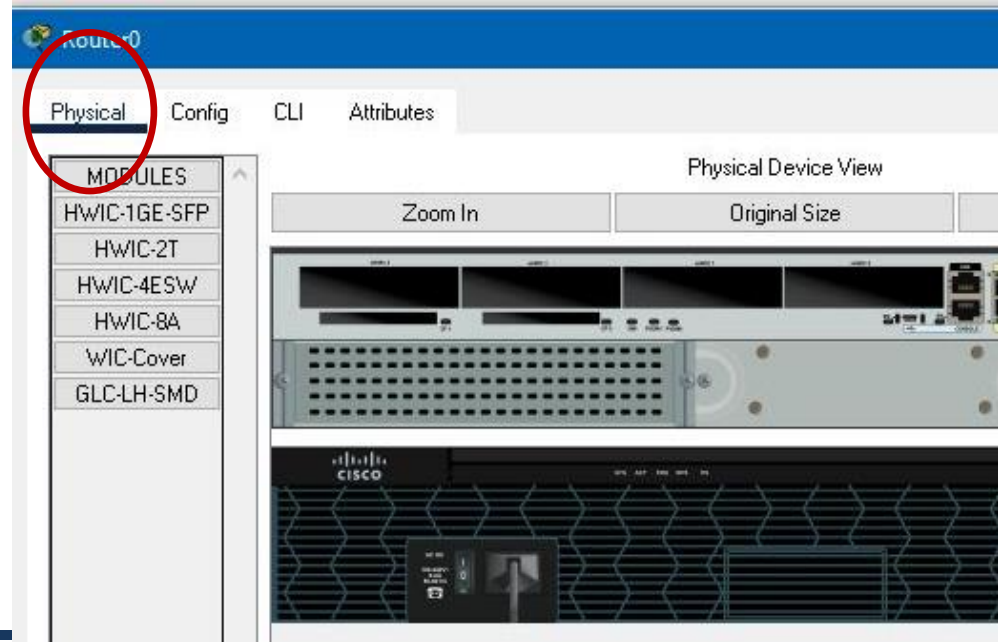

Creating A Simple Network



Turning a Router on or off

- From the device properties window of the Router:
 - Under the **Physical** tab (see Slides 39)
 - Left-click the power button on the router (depicted on the right) to turn the router on or off
 - By default the Router will already be on when placed in the workspace (*the power button can be used to turn off and on the router when necessary*)

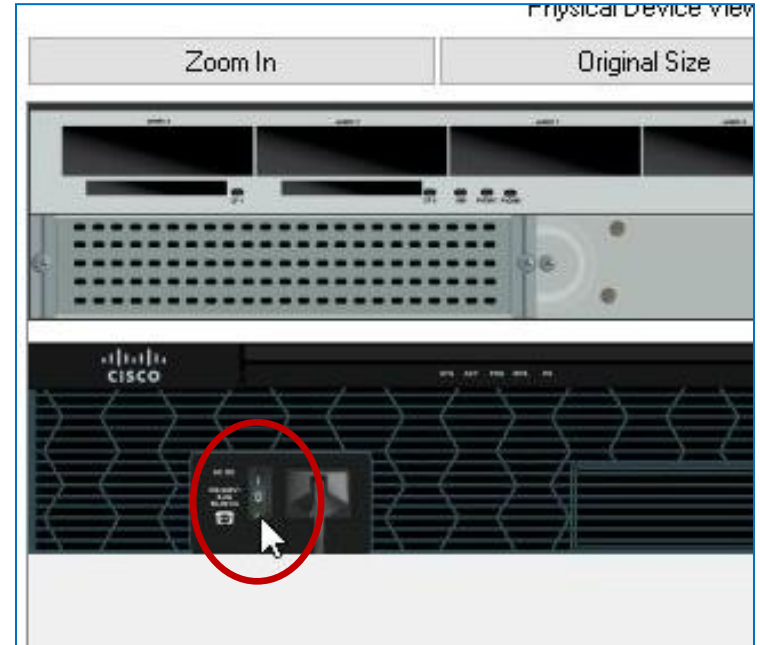



Creating A Simple Network

Changing Config settings for a PC

- Left-click on a PC in the workspace
 - This will bring the device properties window for that PC
 - click on the Config tab

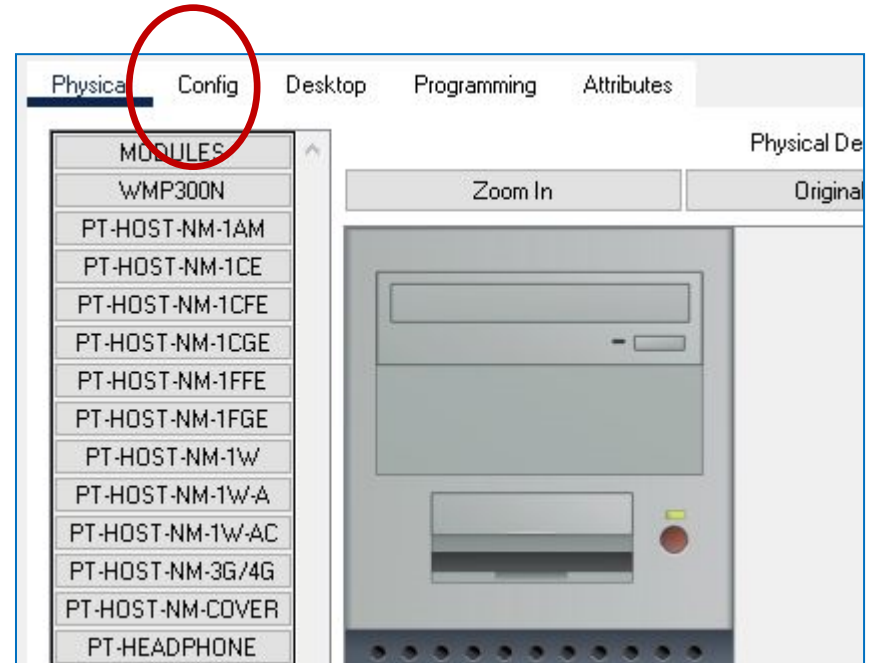



Creating A Simple Network

Changing Config settings for a PC

- The **Config** tab for a PC will show **Global Settings** by default
- The first PC placed into the workspace will be named PC0 by default, its Display Name *can be changed from the Config tab Global Settings*
- (equally the 2nd PC entered into the workspace will be named PC1 (as depicted on the right))

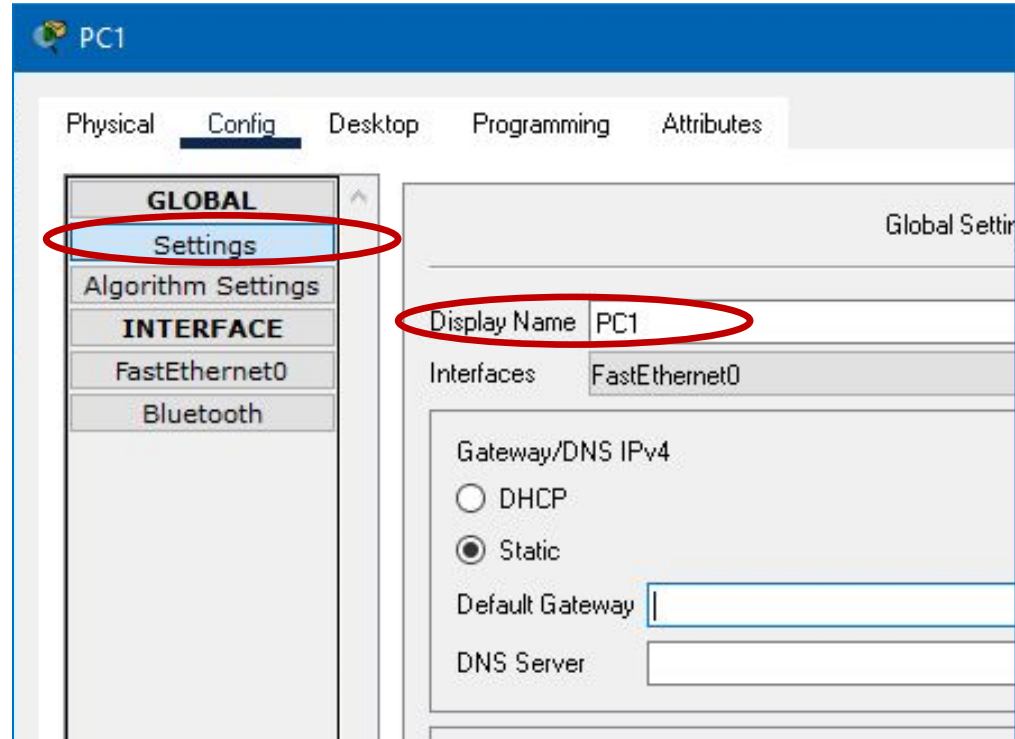



Creating A Simple Network

Changing IP Address settings for a PC

- Under a PC's device properties Config tab:
- Click on the **FastEthernet0** option
 - This will bring options to change the PC's IP address (on the right)

Physical Config Desktop Programming Attributes

FastEthernet0

Port Status

Bandwidth 100 Mbps

Duplex Half Duplex

MAC Address 0006.2A8A.929D

IP Configuration

DHCP

Static

IPv4 Address 192.168.10.11

Subnet Mask 255.255.255.0

IPv6 Configuration

Automatic



Creating A Simple Network

Changing IP Address settings for a PC

- Give PC1 an IP address:
 - **192.168.10.11**
- Subnet mask:
 - **255.255.255.0**

*This will indicate that PC1 is on the Class C network **192.168.10.0 /24***

Physical Config Desktop Programming Attributes

FastEthernet0

Port Status

Bandwidth 100 Mbps 10 Mbps A

Duplex Half Duplex Full Duplex A

MAC Address 0006.2A8A.929D

IP Configuration

DHCP

Static

IPv4 Address 192.168.10.11

Subnet Mask 255.255.255.0

IPv6 Configuration

Automatic



Creating A Simple Network

Closing device properties for a PC

- Click on the X (top right) of the device properties box to return to the workspace
- Alternatively click on an empty space in the workspace to return to the workspace
 - (however this will keep the device properties box open in the background)

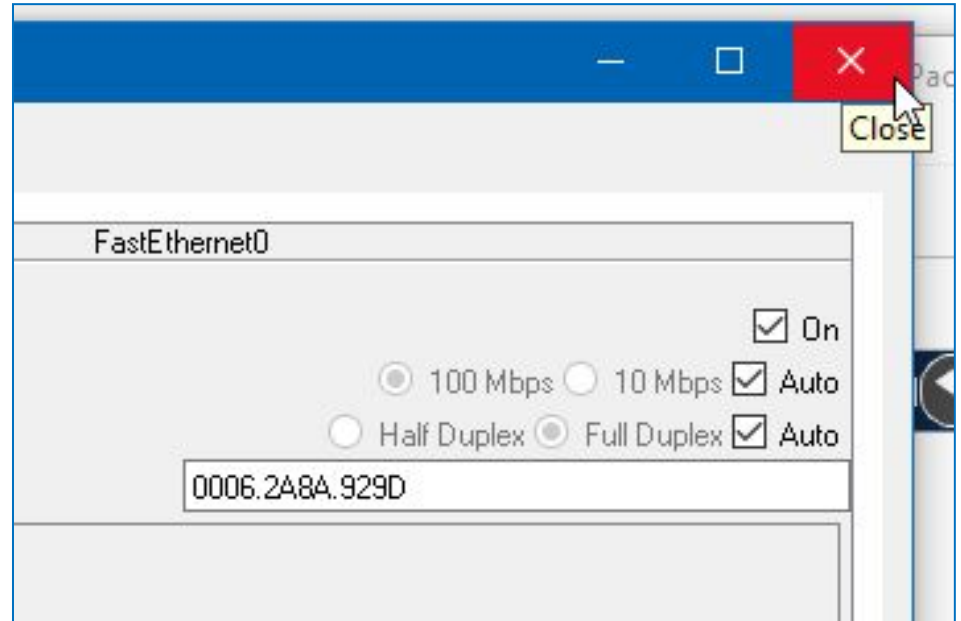



Creating A Simple Network

Minimizing device properties for a PC

- Alternatively, click on an empty space in the workspace to return to the workspace
 - (however this will keep the device properties box open in the background)

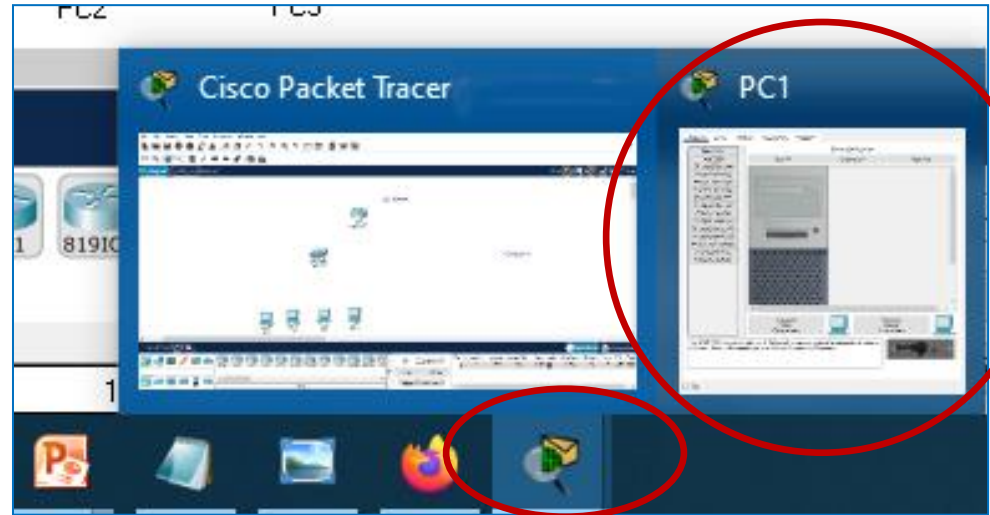



Creating A Simple Network

Viewing the Desktop tab for a PC

- Left-click on PC1 to open the device properties
- Click on the **Desktop** tab to view more settings options available to the PC



Note: There are many options under the **Desktop** tab, however, our focus will be on the **IP Configuration** and **Terminal** options

Creating A Simple Network



Changing IP Address settings for the other PCs

- For each of the other PCs (PC0, PC2 and PC3):
 - Use the **FastEthernet0** setting (see Slide 43) to give the PCs the following **IP addresses**:
 - PC0: **192.168.10.10**
 - PC2: **192.168.10.12**
 - PC3: **192.168.10.13**
 - Set the **subnet mask** (for each PC) to:
 - **255.255.255.0**

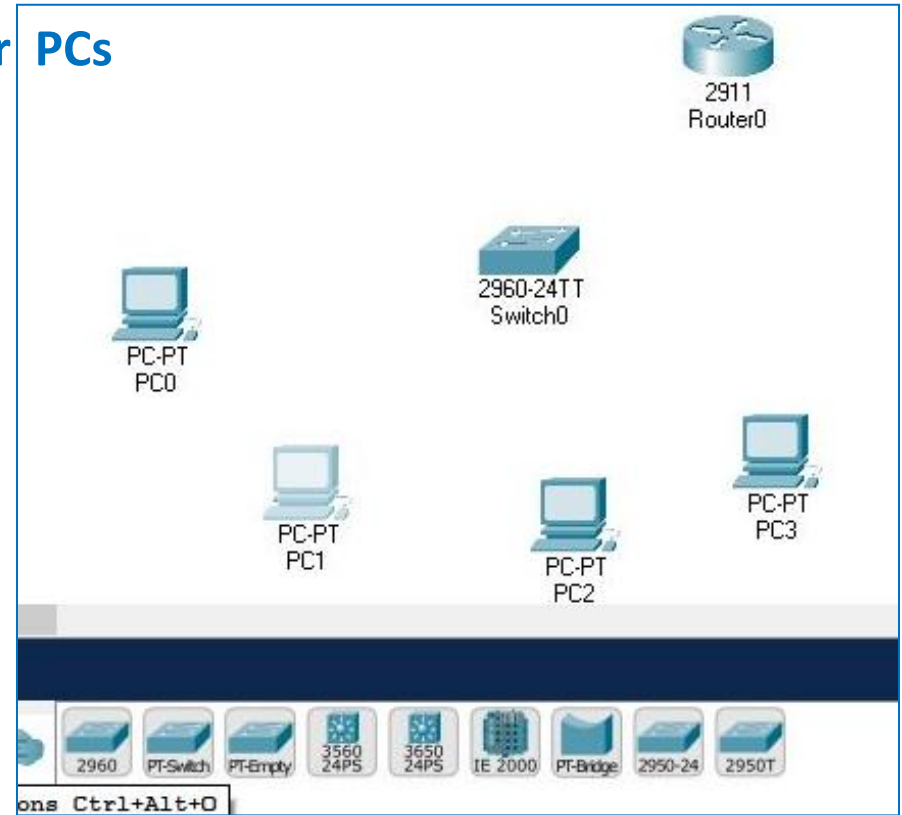

Creating A Simple Network



Changing IP Address settings for the other PCs

- Being a Class C network, the first 3 octets make up the Network ID and the last octet makes the Host ID
- e.g. for PC0 to PC3 the network ID should be the same (**192.168.10**)
- however the last octet should be different to uniquely identify each host on this network,
 - PC0 with IP address 192.168.10.10
 - and PC1 with IP address 192.168.10.11 etc.

Creating A Simple Network

Changing IP Address settings for the other PCs

- Note that with a Class C network:
 - **1** (one) in the last octet is typically reserved for routers ([recommended but not a must](#))
 - e.g. we will set the router's IP address to **192.168.10.1** for our network (later)
 - 2 to 9 in the last octet are usually reserved for shared network such as network printers ([recommended but not a must](#))
 - Hence why we choice to set PC0's IP address to 192.168.10.**10** and above for the other PCs





Creating A Simple Network

Adding cable connections for the PCs

- a) Click on the **Connections** device category

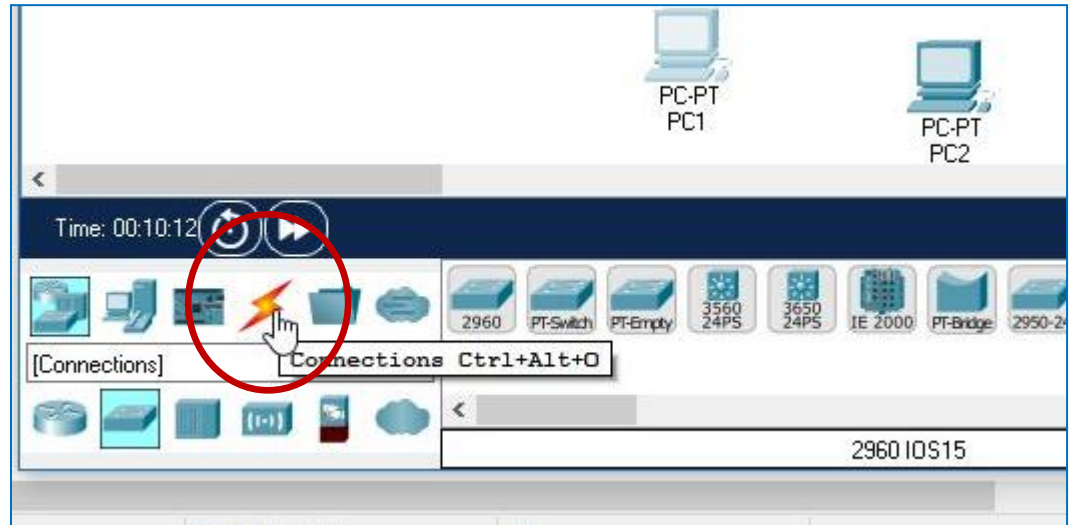



Creating A Simple Network

Adding cable connections for the PCs

- b) Click on the **Connections** device type (bottom left)
 - This will display different cables connection types (on the right side) in Device Specific Selection Box

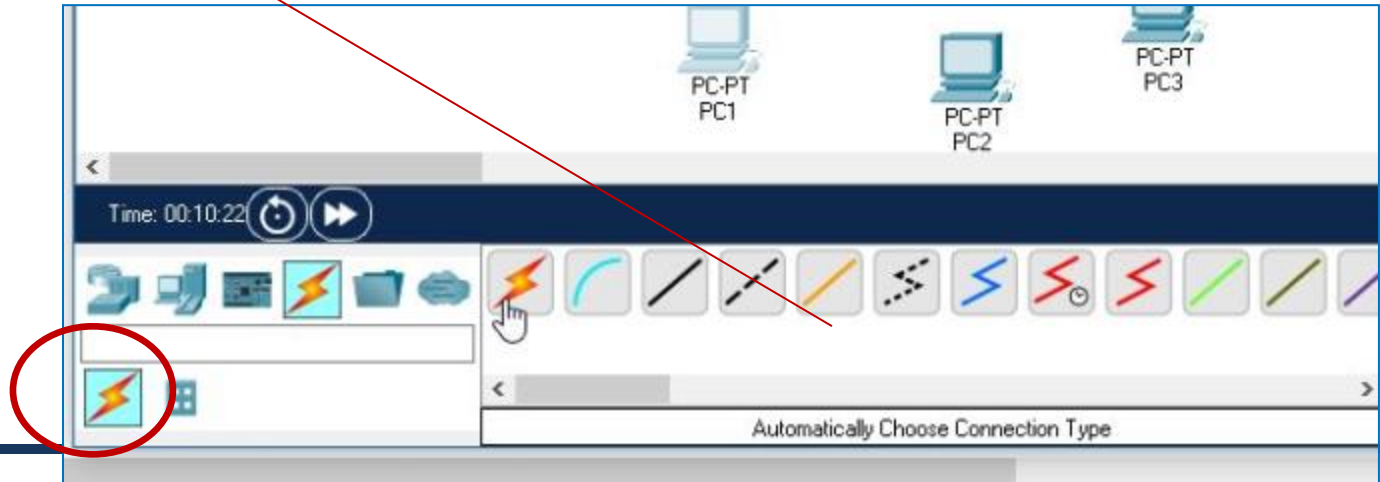



Creating A Simple Network

Adding cable connections for the PCs

- Use a **Straight through** cable to connect a PC to the Switch:
 - Left-click on the Straight through cable

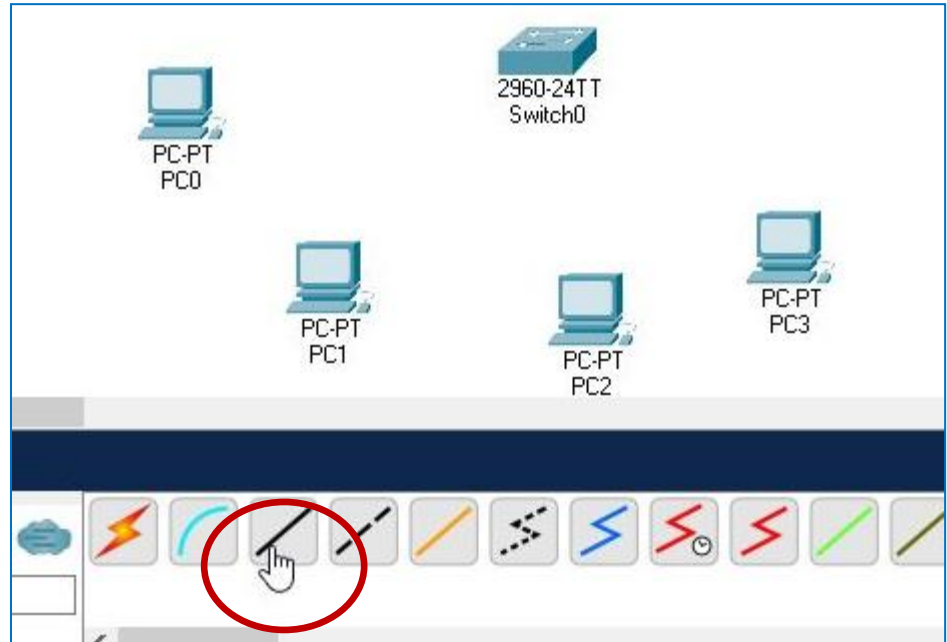



Creating A Simple Network

Adding cable connections for the PCs

- *After clicking on the Straight through cable:*
 - Click on PC0 to indicate the starting point of the cable

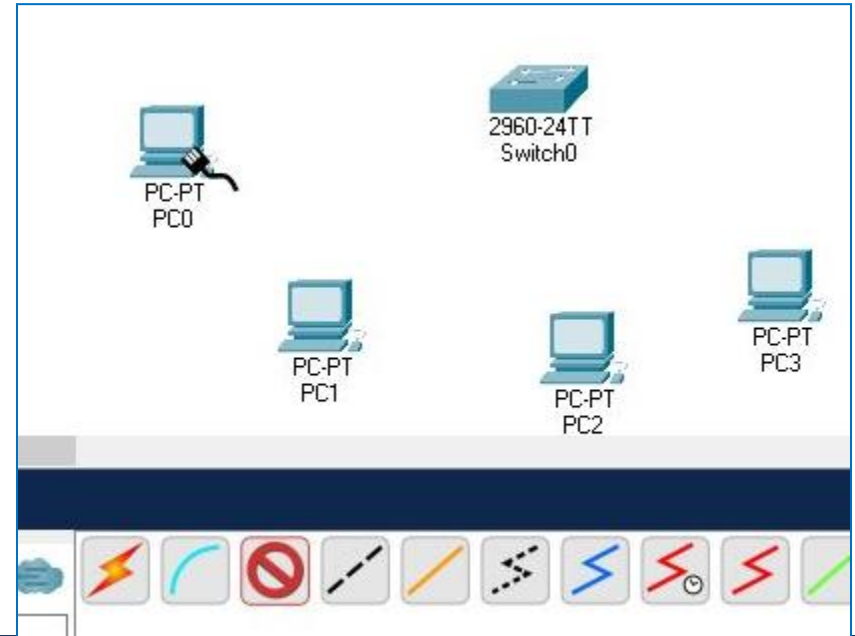

Creating A Simple Network



Adding cable connections for the PCs

- *After click on PC0 with a Straight through cable:*
 - Choose the **FastEthernet0** interface (connection type)
 - By default a PC (in Packet Tracer) will have USB and Fast Ethernet interfaces

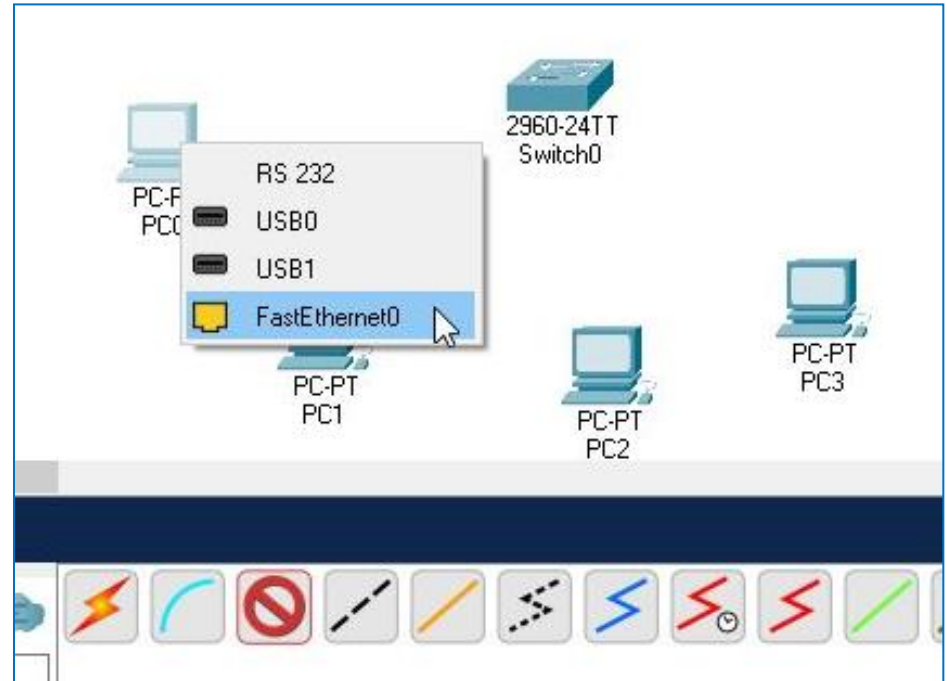

Creating A Simple Network

Adding cable connections for the PCs

- Now click on the Switch to indicate the ending point of the straight through cable:
 - when the Switch is selected, choose the **FastEthernet 0/1** interface (or any Fast Ethernet interface)

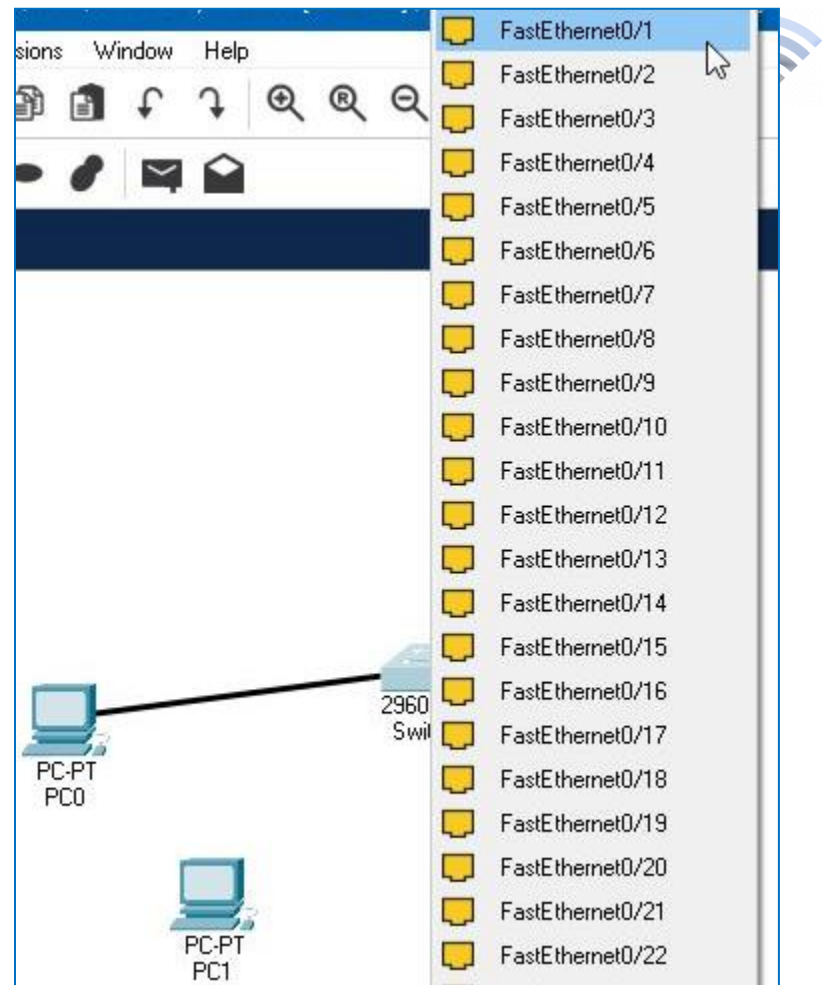

Creating A Simple Network

Adding cable connections for the PCs

- Note that a Switch will have multiple Fast Ethernet interfaces as a Switch is designed to connect multiple network devices to the same LAN

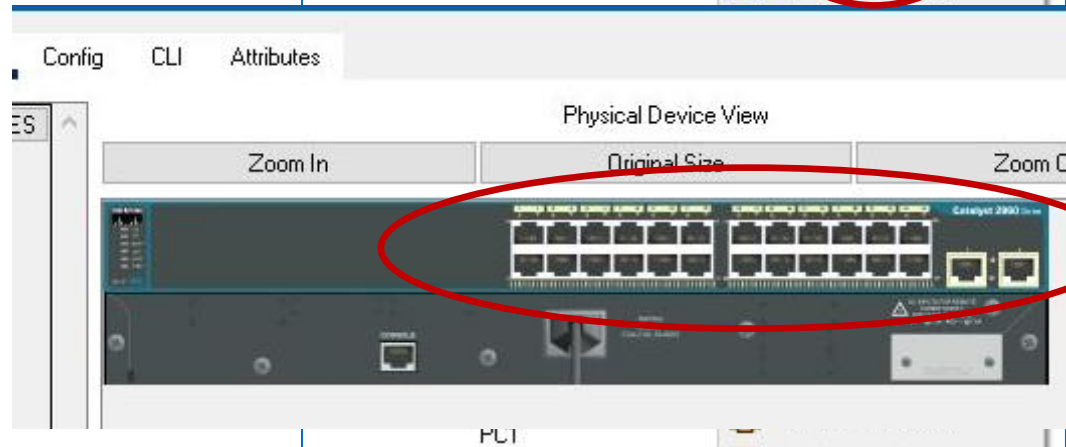
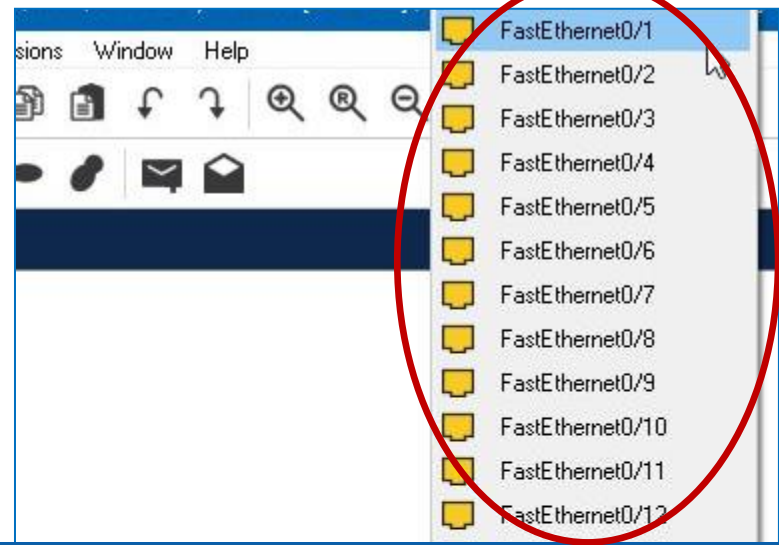

Note: There are also **Gigabit Ethernet** interfaces however our focus will be on a Fast Ethernet Network

Creating A Simple Network



Adding cable connections for the PCs

- Note that a different Switches will have a different number of interfaces (also known as **Ethernet ports**)
 - Switches can have any number of ports between **5 to 52 ports**,
 - when designing a network and choosing which switch to use, **the number of users** (and their devices) to be connected to a LAN will need to be considered





Creating A Simple Network

Adding cable connections for the PCs

- Continue adding straight through cables for the other PCs
- i.e. PC1 **FastEthernet0** connected to Switch **FastEthernet0/2**
- PC2 **FastEthernet0** connected to Switch **FastEthernet0/3**
- and PC3 **FastEthernet0** connected to Switch **FastEthernet0/4**

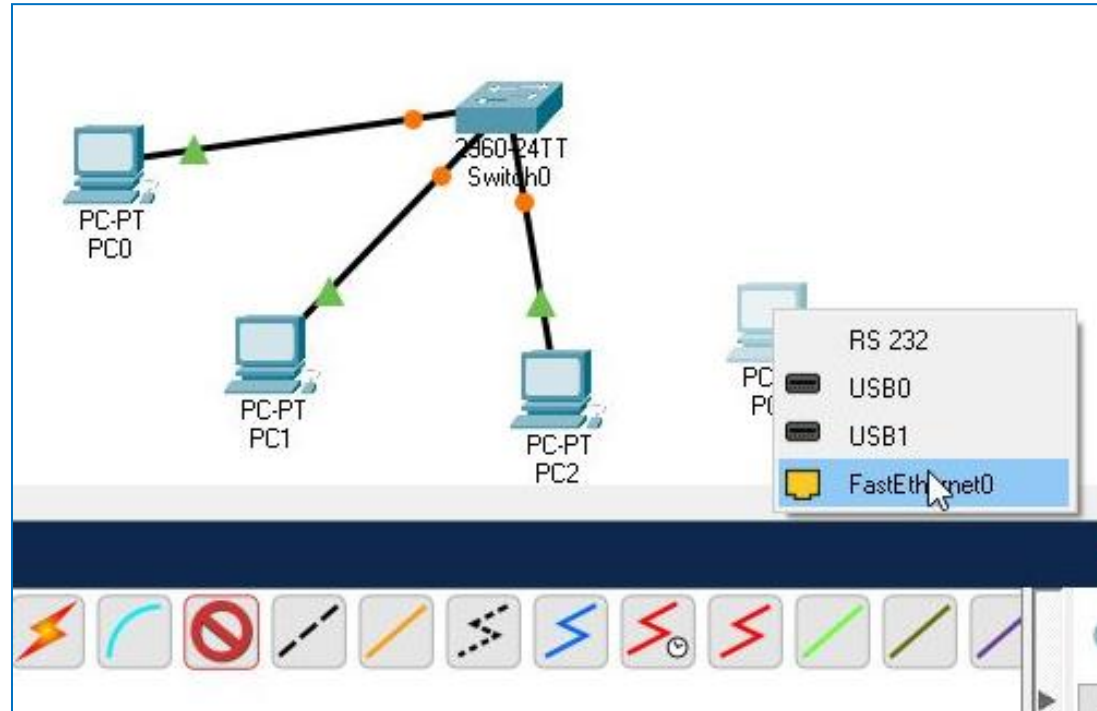



Creating A Simple Network

A simple Local Area Network is complete

- Through the use of the Switch, the PCs will be able to send packets (data) to each other (even before a router is used)
- In Packet Tracer, connections will be represented in **green** when the connection has been established successfully

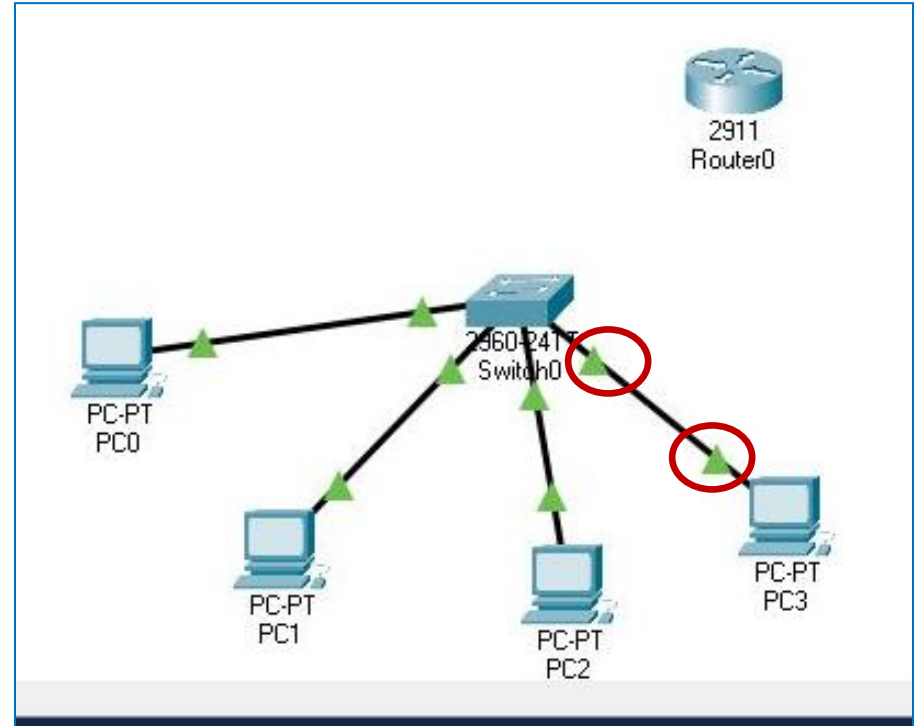



Creating A Simple Network

A simple Local Area Network is complete

- A connection will be represented in **red** if a PC is turned off
 - (see Slides 83 for turning off a PC)
- *Additionally, a connection will be red if a Router has not been configured properly*

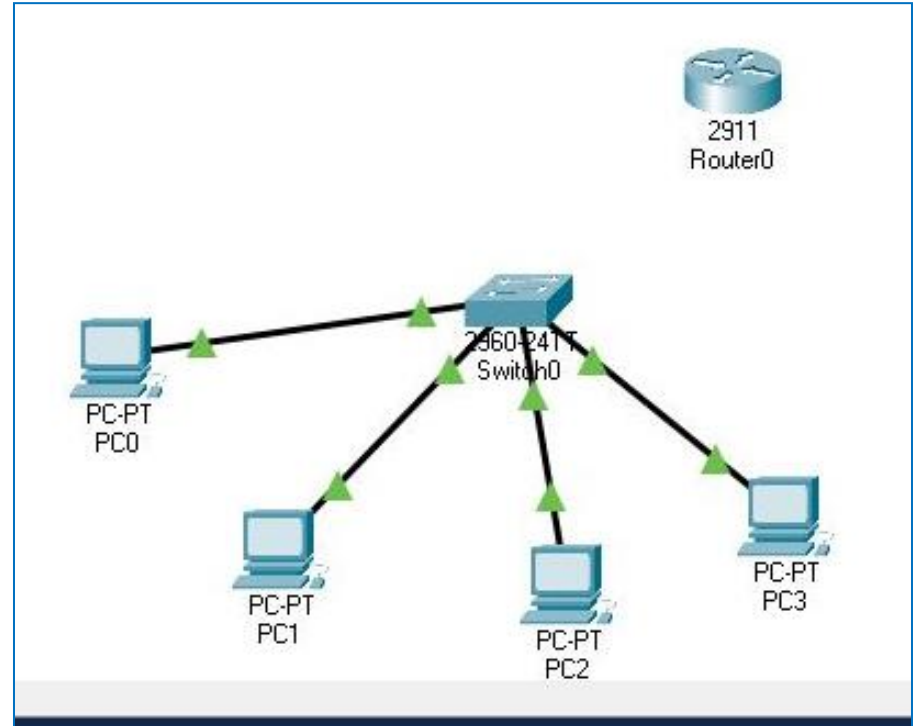

Creating A Simple Network



A simple Local Area Network is complete

- Note: the straight through cables in a real network will most likely not connect from a PC to a Switch in a straight line as indicated in Packet Tracer's Logical Workspace
 - however the Logical Workspace is a suitable logical representation of a real network

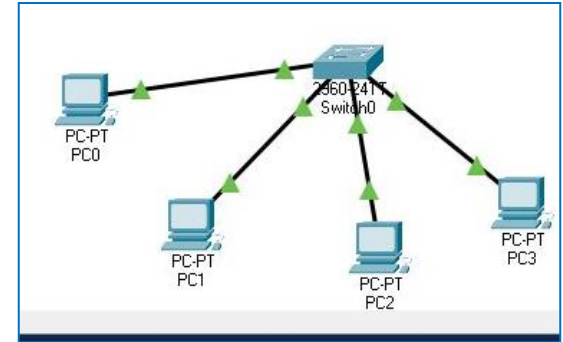

Creating A Simple Network

A simple **Local Area Network** is complete

- Cables in a real network will likely run along walls and into other rooms until connecting to a Switch (which will usually be placed in a **network cabinet**)
 - This can include a wall mounted network cabinet



Creating A Simple Network



Expanding the simple LAN

- Set the default gateway of PC1 to **192.168.10.1**
 - In preparation for connecting the LAN to another LAN using **routers**
 - go to PC1's **device properties** > **Desktop** tab > **IP Configuration** option > type in the Default Gateway, then close the device properties

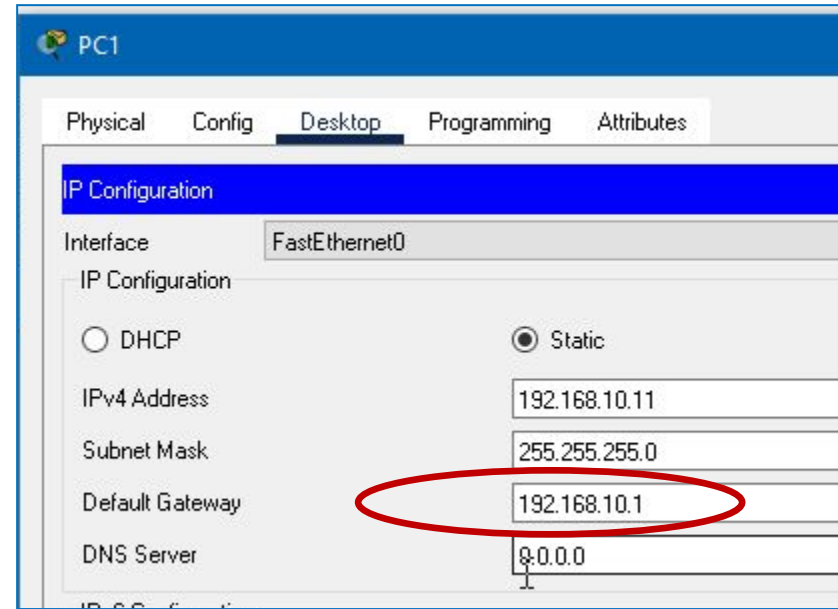

Creating A Simple Network



Expanding the simple LAN

- Set the default gateway of the other **3 PCs** to **192.168.10.1** as well
 - This will be the IP address for the router
- A **network gateway** is a network device that forwards and receives data to and from another network
 - i.e. a router is a network gateway for LANs

A screenshot of a network configuration window titled "IP Configuration" for the "FastEthernet0" interface. The window has tabs for "Physical", "Config", "Desktop", "Programming", and "Attributes". The "IP Configuration" section shows the following settings:

Field	Value
Interface	FastEthernet0
IP Configuration	
<input type="radio"/> DHCP	<input checked="" type="radio"/> Static
IPv4 Address	192.168.10.11
Subnet Mask	255.255.255.0
Default Gateway	192.168.10.1
DNS Server	8.0.0.0

Expanding the simple LAN – device information



- Hover the mouse of a PC to see more information about that PC, Information such:
 - as the IP address on the PC's **FastEthernet** port
 - the Gateway IP address

PC-PT
PC-PT
PC-PT
PC-PT

PC-PT
PC-PT

```
Device Name: PC1
Device Model: PC-PT

Port          Link  IP Address
FastEthernet0 Up    192.168.10.10
Bluetooth     Down  <not set>

Gateway: 192.168.10.1
DNS Server: <not set>
Line Number: <not set>

Physical Location: Intercity > H
```



Expanding the simple LAN – changing a PC's Display Name without the device properties window

- Click on a PC's display name in the workspace, this will bring an input field
 - Type in the PC's display name and hit enter.
 - An alternative way of changing a display name

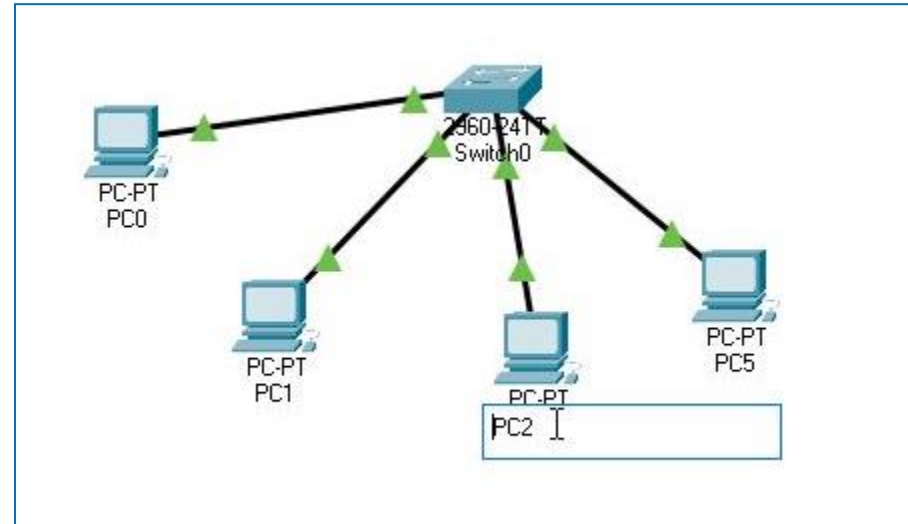

This can also be achieved by opening the Device Properties (**left click on the device**) > **Config** tab > enter a name in the **Display name field** (see the image on Slide 42)



Testing the simple LAN – using the ping command

- The ping command can be used (PCs and routers) to check if a packet successfully reached a destination device
 - i.e. a form of testing the network connectivity
- To use the ping command on PC1: go to PC1's **device properties** > **Desktop** tab > **Command Prompt** option
 - Note: click the blue X on a desktop option to return to all the desktop options

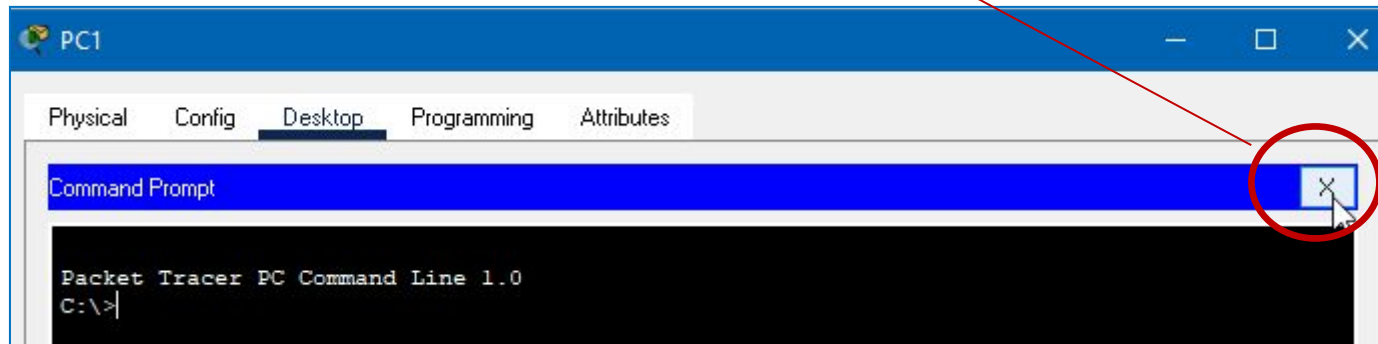



Testing the simple LAN – using the ping command

- From PC1's **command prompt**:
- type in `ping 192.168.10.13`
- to send a packet to PC3

syntax:

```
ping ip_address
```

- A ping request will send 4 replies for a good connection
 - (i.e the packet was sent to PC3 and PC3 sent a packet back to PC1 successfully)

```
Command Prompt

Packet Tracer PC Command Line 1.0
C:\>ping 192.168.10.13

Pinging 192.168.10.13 with 32 bytes of data:

Reply from 192.168.10.13: bytes=32 time<1ms TTL=128
Reply from 192.168.10.13: bytes=32 time<1ms TTL=128
Reply from 192.168.10.13: bytes=32 time<1ms TTL=128
Reply from 192.168.10.13: bytes=32 time=4ms TTL=128

Ping statistics for 192.168.10.13:
    Packets: Sent = 4, Received = 4, Lost = 0 (0% loss),
    Approximate round trip times in milli-seconds:
        Minimum = 0ms, Maximum = 4ms, Average = 1ms

C:\>|
```

Testing the simple LAN – using the ping command



- A ping request will send 4 **Request timed out** messages if the packet was not transmitted successfully
 - i.e. the two devices are not properly connected
 - this error message will occur if the ping command's IP address is not actually associated to any device on the network (as depicted on the right)

```
C:\>ping 192.168.10.99
Pinging 192.168.10.99 with 32 bytes of data:
Request timed out.
Request timed out.
Request timed out.
Request timed out.

Ping statistics for 192.168.10.99:
    Packets: Sent = 4, Received = 0, Lost = 4 (100%
C:\>
```

Testing the simple LAN – using the ping command



- A ping request will send 4 **Request timed out** messages if the packet was not transmitted successfully

Note that a ping request with 1 timeout and 3 replies can be regarded as a suitable connection, i.e. the packets had a problem but were not all lost

```
C:\>ping 192.168.10.99

Pinging 192.168.10.99 with 32 bytes of data:

Request timed out.
Request timed out.
Request timed out.
Request timed out.

Ping statistics for 192.168.10.99:
    Packets: Sent = 4, Received = 0, Lost = 4 (100%
C:\>
```





Expanding the simple LAN – adding a laptop and a server

- Click on the **End Devices** device category
- Click on the **End Devices device** type
- Drag and drop a laptop into the workspace
- Drag and drop a server into the workspace

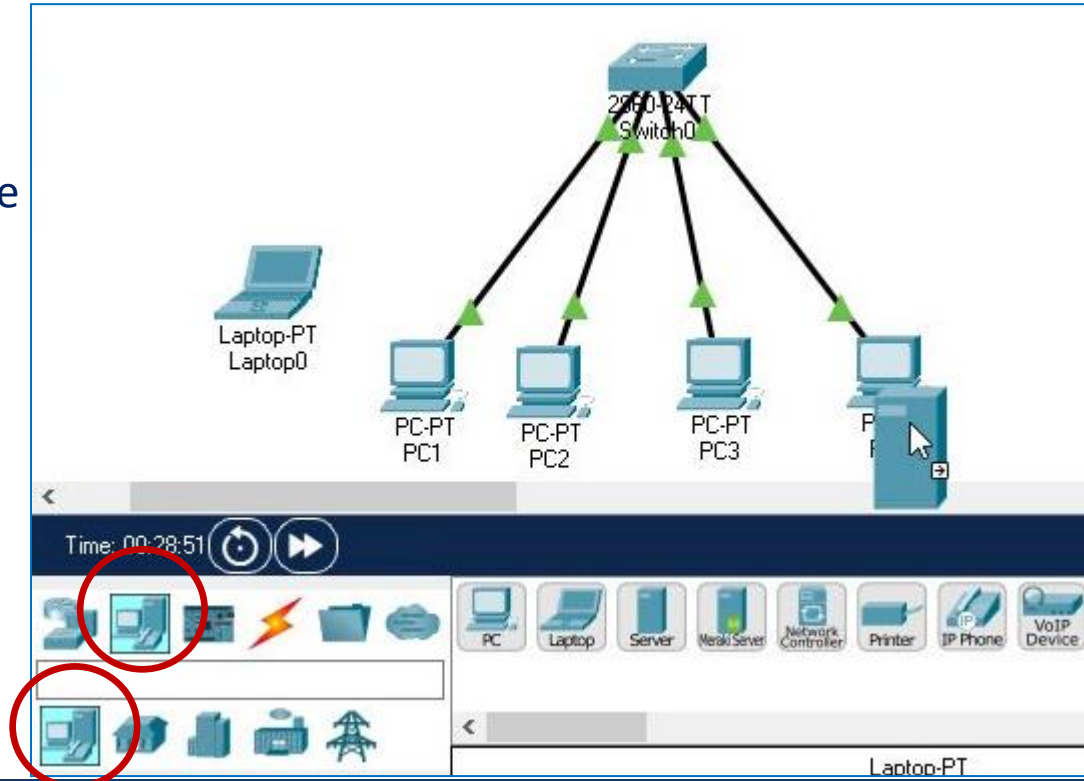



Expanding the simple LAN – adding a laptop and a server

- Change the laptop and server Display Names (indicated on the right)
- Connect the laptop and the server to the switch using straight through cable connections

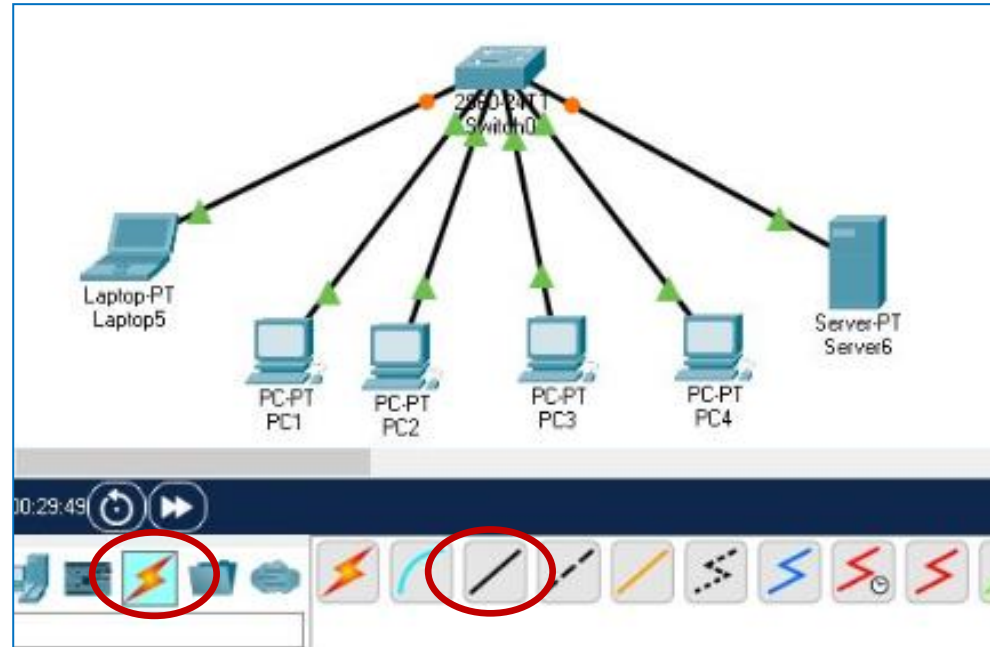



Expanding the simple LAN – adding a laptop and a server

- Give the laptop an IP address:
 - IP address: **192.168.10.15**
 - Subnet mask: **255.255.255.0**
 - Default Gateway: **192.168.10.1**
- Give the server an IP address:
 - IP address: **192.168.10.16**
 - Subnet mask: **255.255.255.0**
 - Default Gateway: **192.168.10.1**

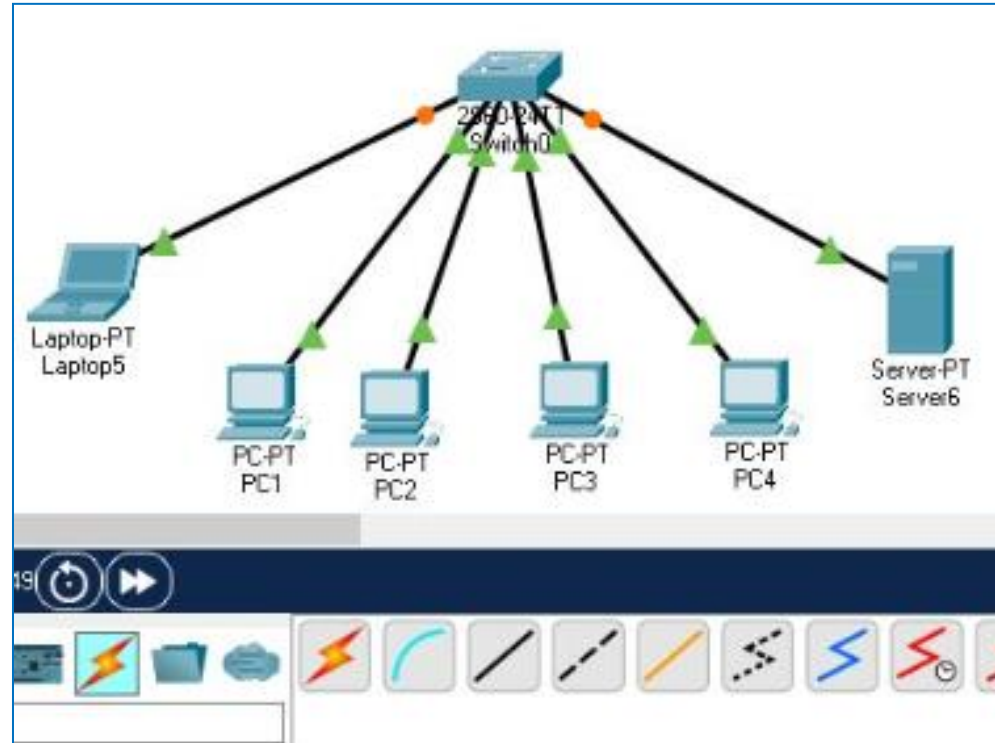



Viewing the simple LAN - moving multiple devices in the workspace

- Click and drag from an empty space in the workspace in order to select multiple devices

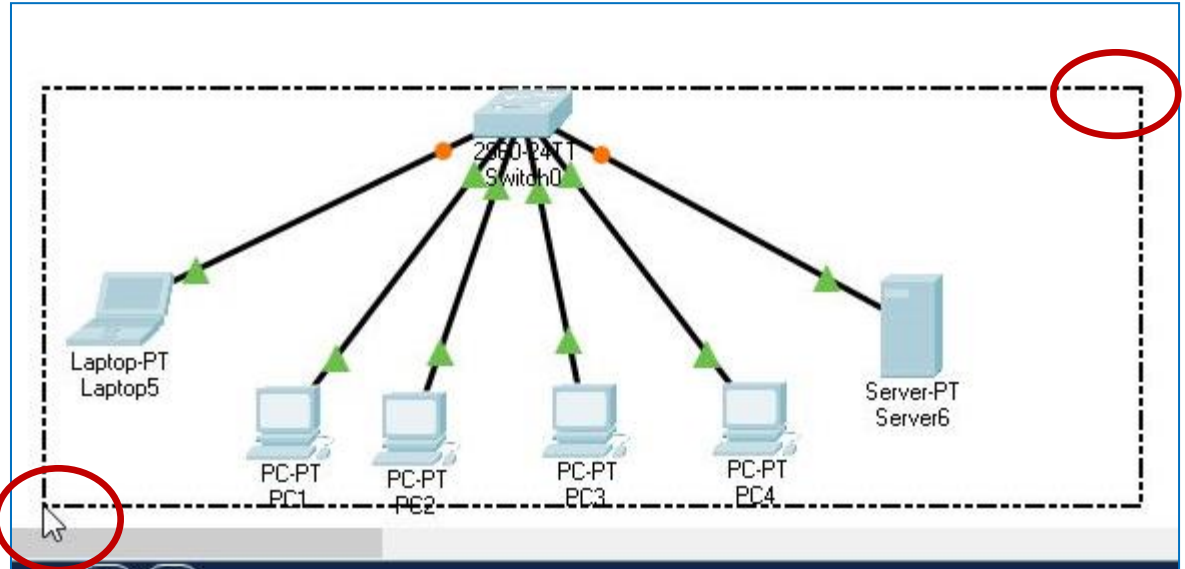



Viewing the simple LAN - moving multiple devices in the workspace

- With multiple devices selected:
 - click and drag any of the selected objects to move all of the selected devices
 - i.e. to move the entire LAN within the workspace

- click on an empty space in the workspace to deselect the selected devices

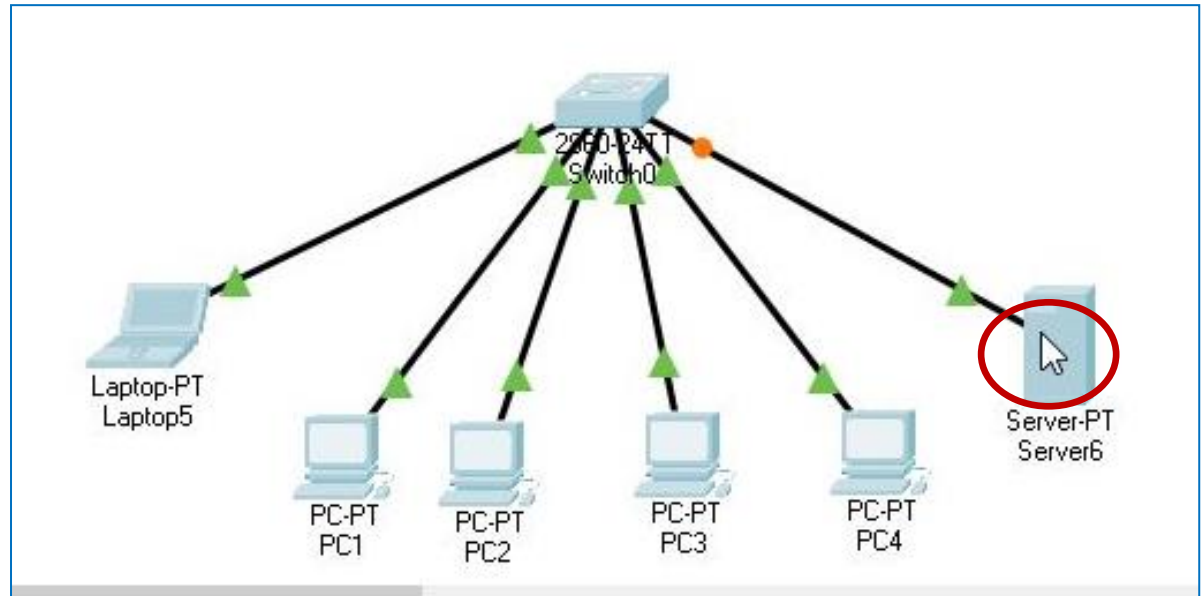



Viewing the simple LAN - zooming in the workspace

- Use the **Ctrl** key + the **mouse wheel** to zoom in and out in the workspace

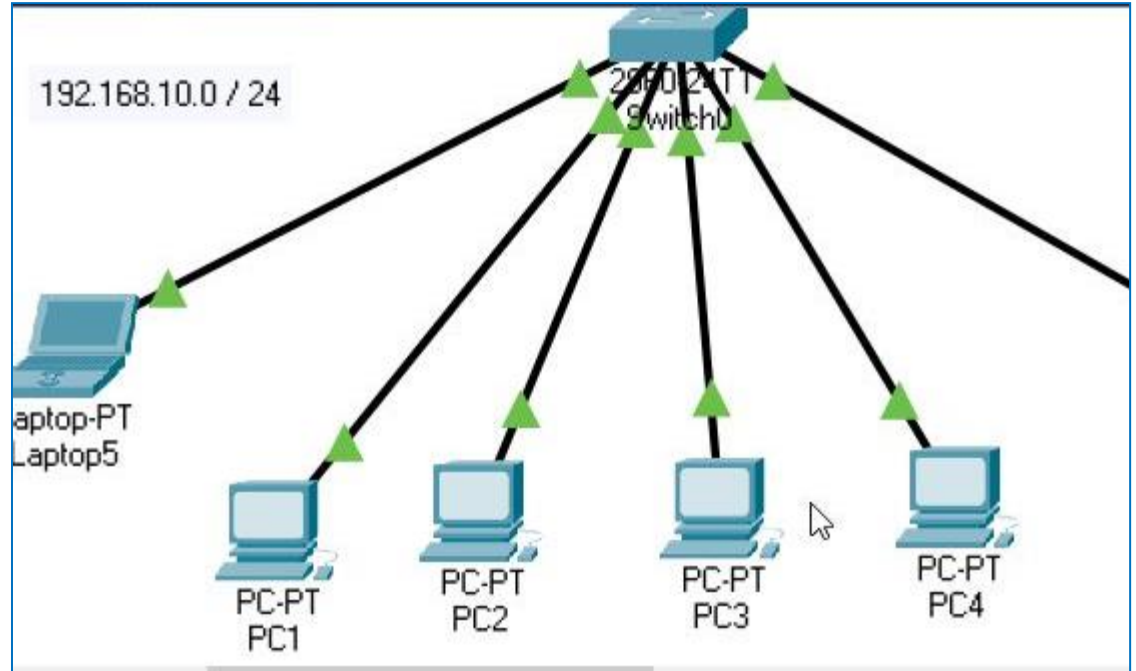



Viewing the simple LAN - zooming in the workspace

- Alternatively use the zoom in and zoom out icons to zoom in and out in the workspace

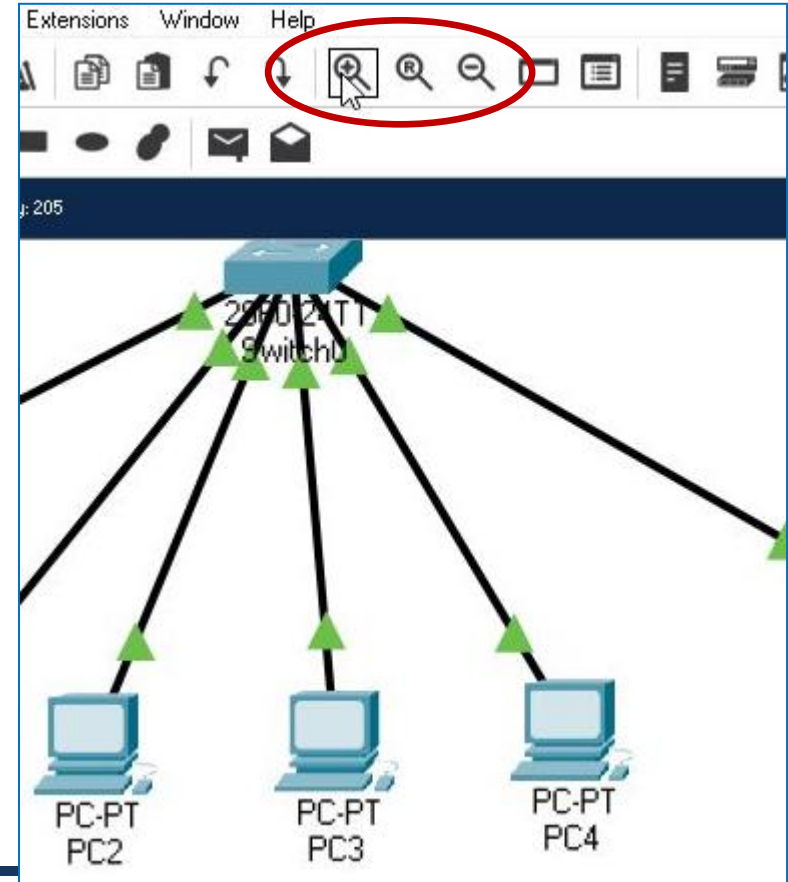



Viewing the simple LAN - moving in the workspace

- Use the **mouse wheel** to move **vertically** in the workspace
- Use the **Alt** key + the **mouse wheel** to move horizontally in the workspace
- Alternatively click and drag the workspace scrollbars
 - bottom scrollbar to move horizontally
 - right scrollbar to move vertically

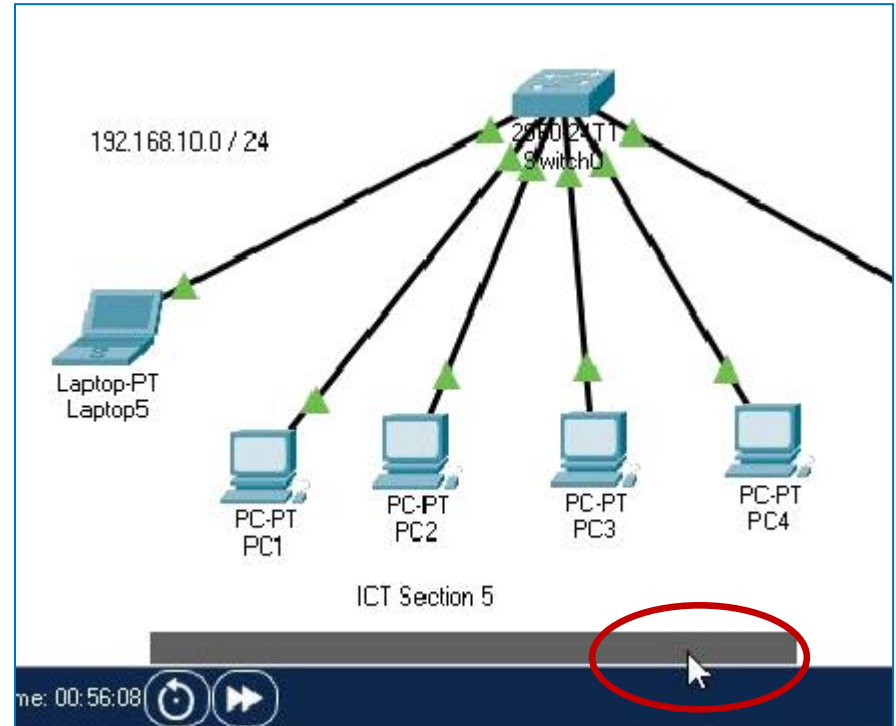



Expanding the simple LAN – adding a note in the workspace

- Click on the **Place Note** icon, then click on an empty space in the workspace to add a note
 - Type in the note then hit enter

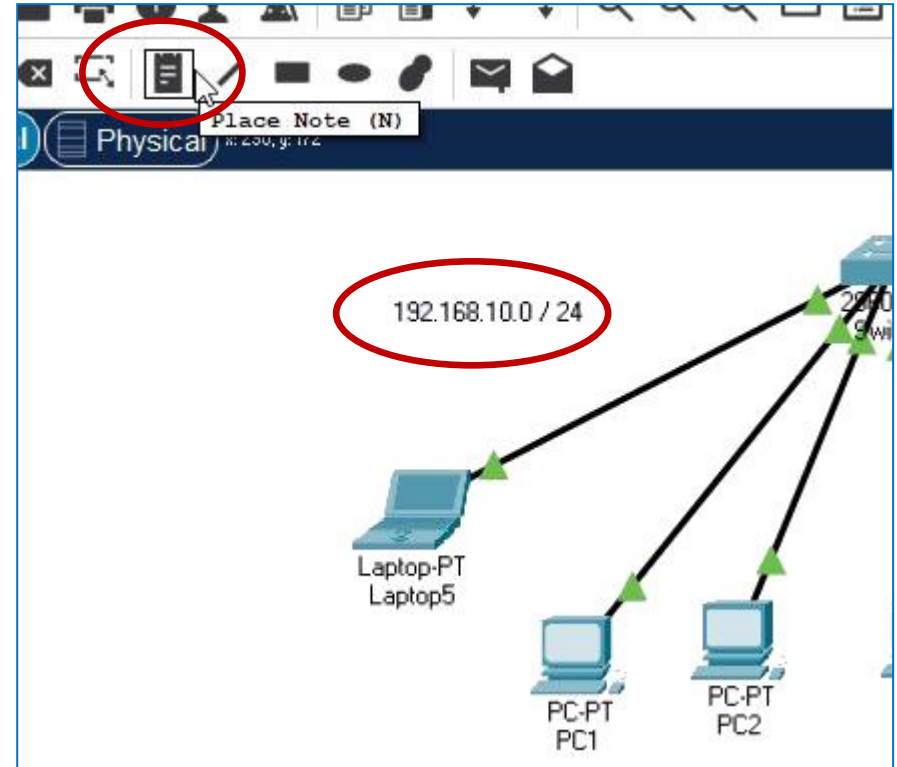

Expanding the simple LAN – modifying a PC's physical modules

- Open a PC's device properties, go to the **Physical** tab
- Drag and drop a PC's Fast Ethernet interface / port / module (named **PT-HOST-NM-1CFE**) from the and onto the Modules list (*as depicted in the next slide*)

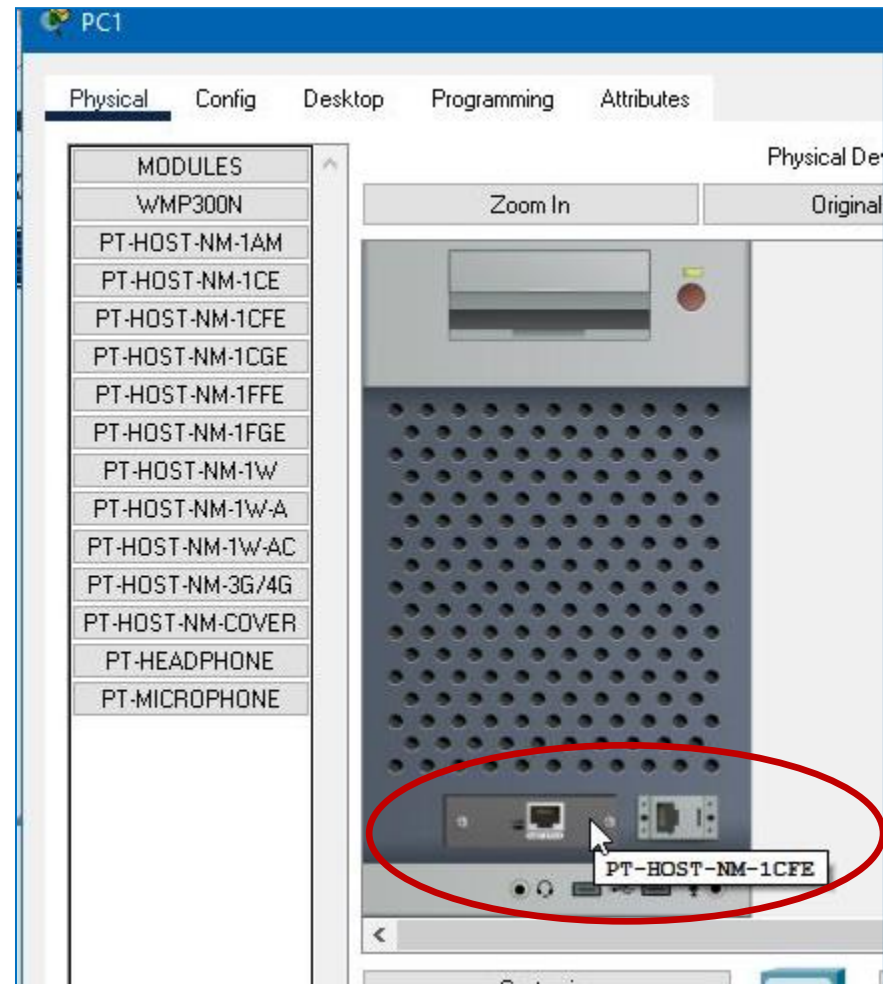



Expanding the simple LAN – modifying a PC's physical modules

- Note that a Gigabit Ethernet port / module (named **PT-HOST-NM-ICGE**) can only be added if the Fast Ethernet port is first removed

Note 2: for our simple LAN we will keep the Fast Ethernet port. A Gigabit Ethernet port could be added but keep in mind some routers are not able to support a Gigabit Ethernet network



Drag and drop from the PC to the Modules list empty space



Expanding the simple LAN – almost modifying a PC's physical modules

- Additionally note that a PC's physical modules can not be changed while the PC is on (in Packet Tracer)
 - Attempting to do so will bring up an error message

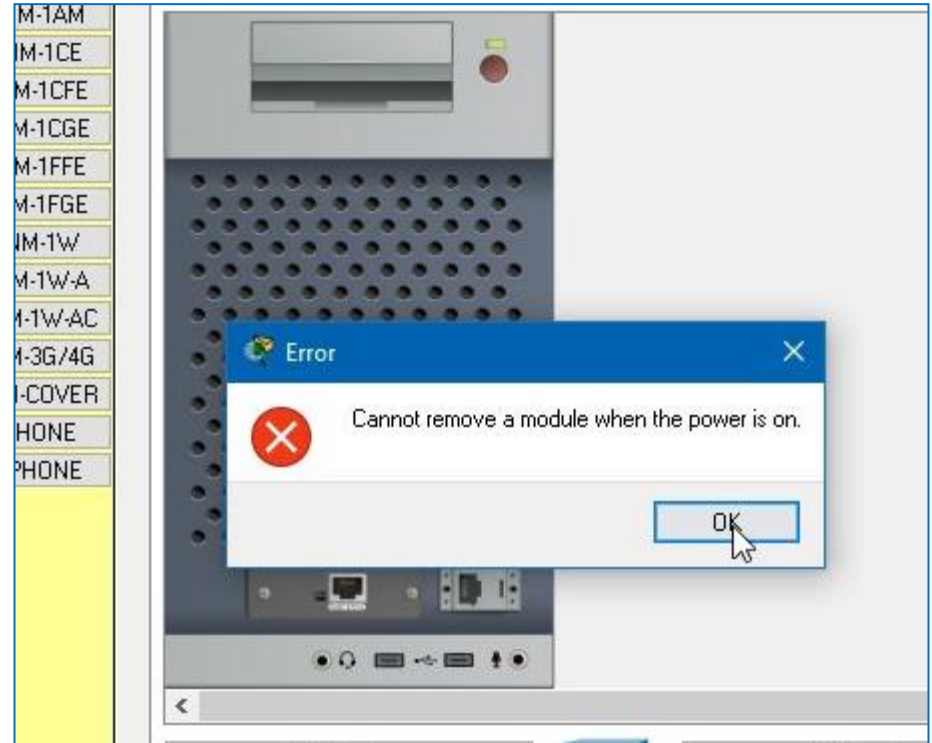

Expanding the simple LAN – almost modifying a PC's physical modules



- Turn off the PC by clicking the **PC's red power** before attempting to change / drag and drop physical modules
- A **green** indicator (above the red power button) indicates that the PC is on
- A **grey** indicator (above the red power button) indicates that the PC is off

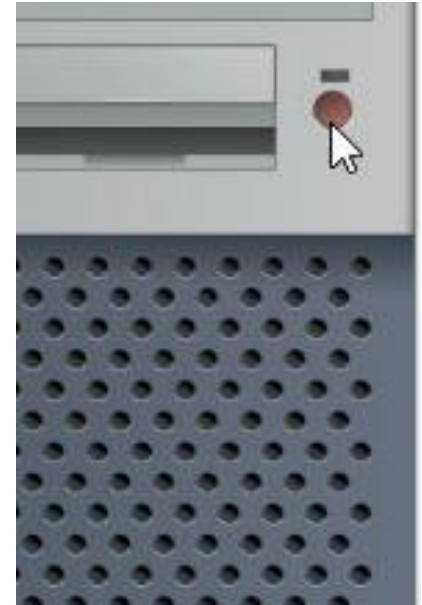
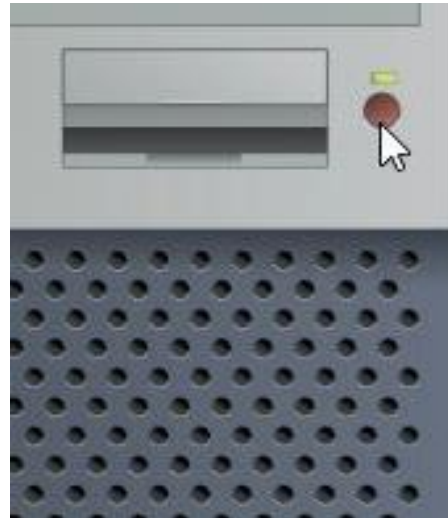



Expanding the simple LAN – turning a PC off and on

- The PC's connection will be indicated with red arrows if a PC is off
- Packets will not be sent to that PC when the PC is off, remember to turn a PC back on when necessary:
 - Go to the PC's device properties and click on the red power button

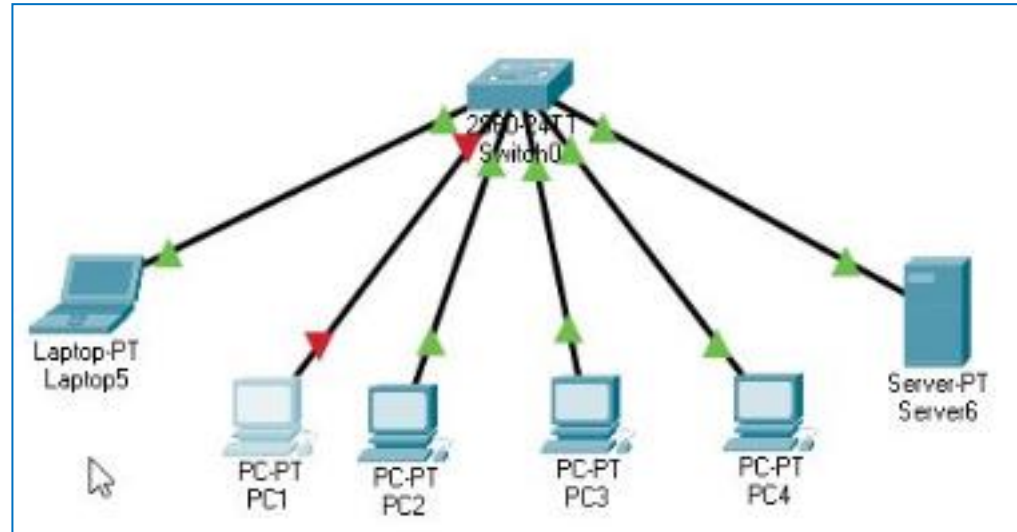



Not expanding the simple LAN – deleting network devices

- Click on the **Delete** icon (above the Workspace Type Bar)
 - then click on a network device to be deleted





Not expanding the simple LAN – deleting network devices

- A network device will bring up a delete prompt (to ask if you are sure you want to delete a device) click **Delete** to confirm the delete
- Note however that a cable connection will **not** bring up a delete prompt, *with the Delete icon selected*: clicking on a cable connection will delete the cable instantly

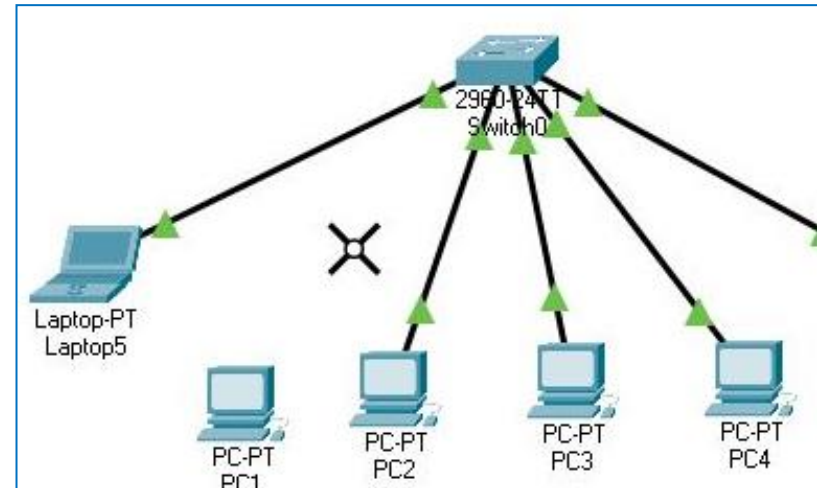
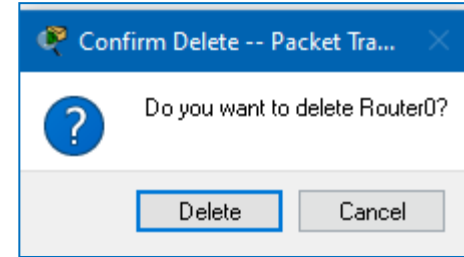



Expanding the simple LAN – return to selecting network devices

- Click on the **Select** icon, to restore the option to select devices, *after making any necessary deletions*

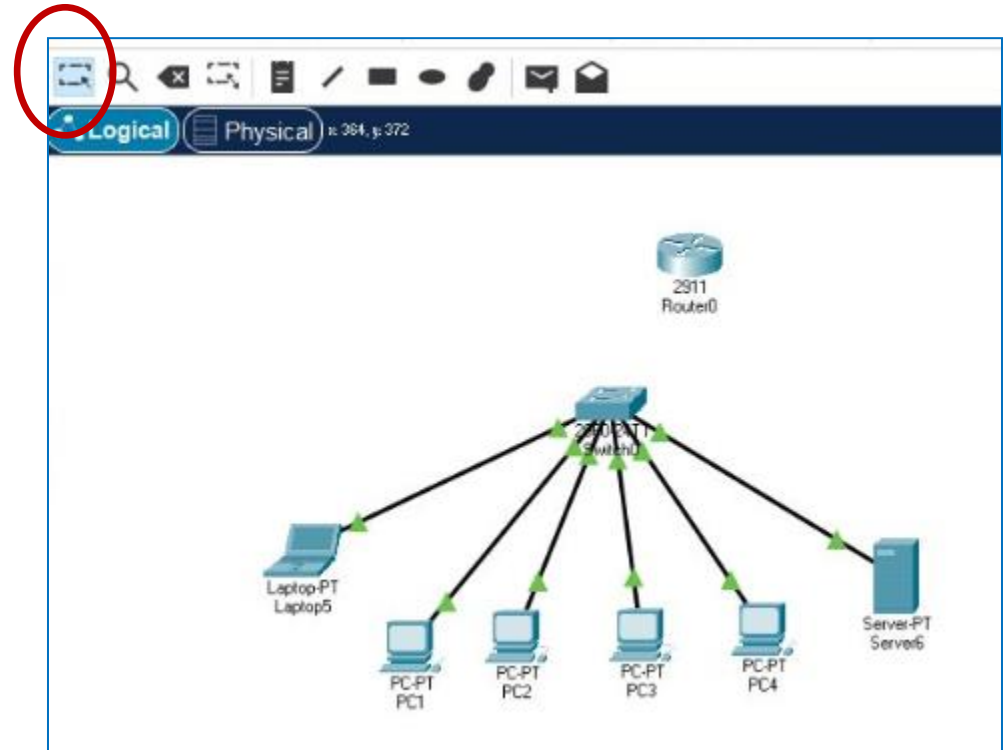



The simple LAN summary

- This Local Area Network consists of 4 PCs, 1 laptop and 1 server connected to 1 switch
- The network connectivity of a Packet Tracer network can also be testing using **Simulation Mode** (in addition to using the ping command)

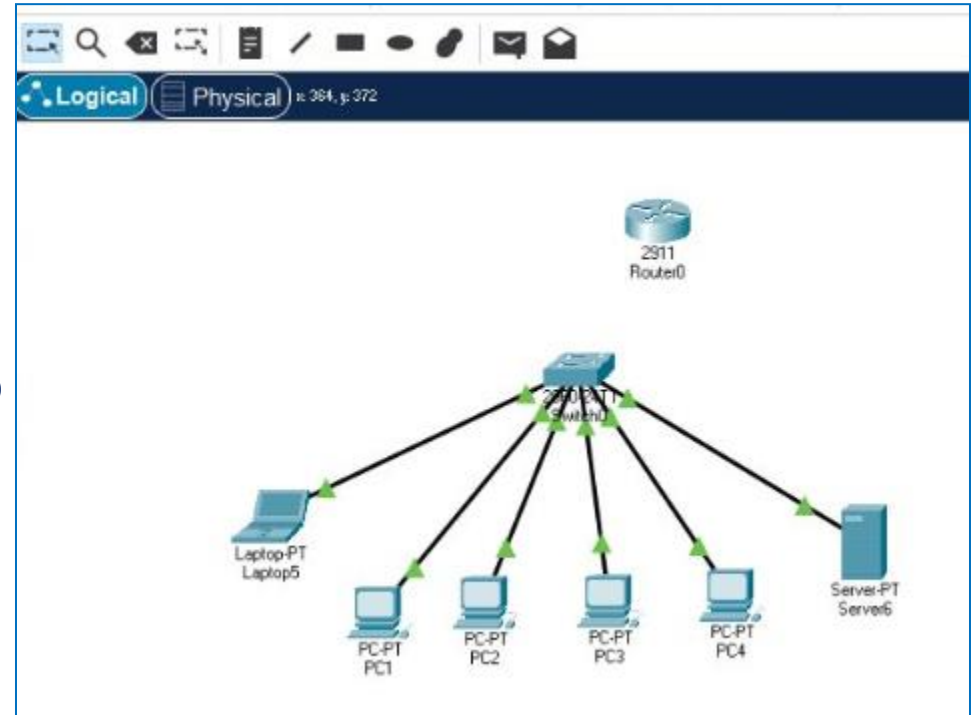



The simple LAN and Simulation Mode

- Click on **Simulation Mode** (bottom right) to enter Simulation mode

Click on Realtime mode to exit simulation mode when necessary)

The screenshot displays a network simulation environment. On the left, a central switch labeled '2400-2411 Switch0' is connected to four devices: three PCs labeled 'PC-PT PC2', 'PC-PT PC3', and 'PC-PT PC4', and a server labeled 'Server-PT Server6'. The interface includes a top control bar with 'Reset Simulation', a checked 'Constant Delay' box, and a 'Captured to: (no captures)' field. Below this is a 'Play Controls' section with play, stop, and back buttons. A large 'Event List Filters - Visible Events' list is shown, containing protocols such as ACL Filter, ARP, BGP, Bluetooth, CAPWAP, CDP, DHCP, DHCPv6, DNS, DTP, EAPOL, EIGRP, EIGRPv6, FTP, H.323, HSRP, HSRPv6, HTTP, HTTPS, ICMP, ICMPv6, IPSec, ISAKMP, IoT, IoT TCP, LACP, LLDP, Meraki, NDP, NETFLOW, NTP, OSPF, OSPFv6, RADIUS, POP3, PPP, PPPoE, PTP, RADIUS, REP, RIP, RIPng, RTP, SCCP, SMTP, SNMP, SSH, STP, and SYSLOG. At the bottom, a navigation bar features 'Event List', 'Realtime', and 'Simulation' buttons, with the 'Simulation' button circled in red. Below the navigation bar is a toolbar with various drawing tools and a 'Scenario 0' dropdown menu with 'New' and 'Delete' buttons.



The simple LAN and Simulation Mode

- **Realtime Mode**

- Shows the user network changes in real-time
- The network devices respond as real devices do, with immediate real-time response for all network activities

- **Simulation Mode**

- Allows the user to view packets moving from one node to another,
- The user can also click on a packet to view more information about the packet

The simple LAN and Simulation Mode

When in Simulation Mode

- Packets can be sent from one device to another using the option to **Add Simple PDU**
 - Click on the **Add Simple PDU** icon

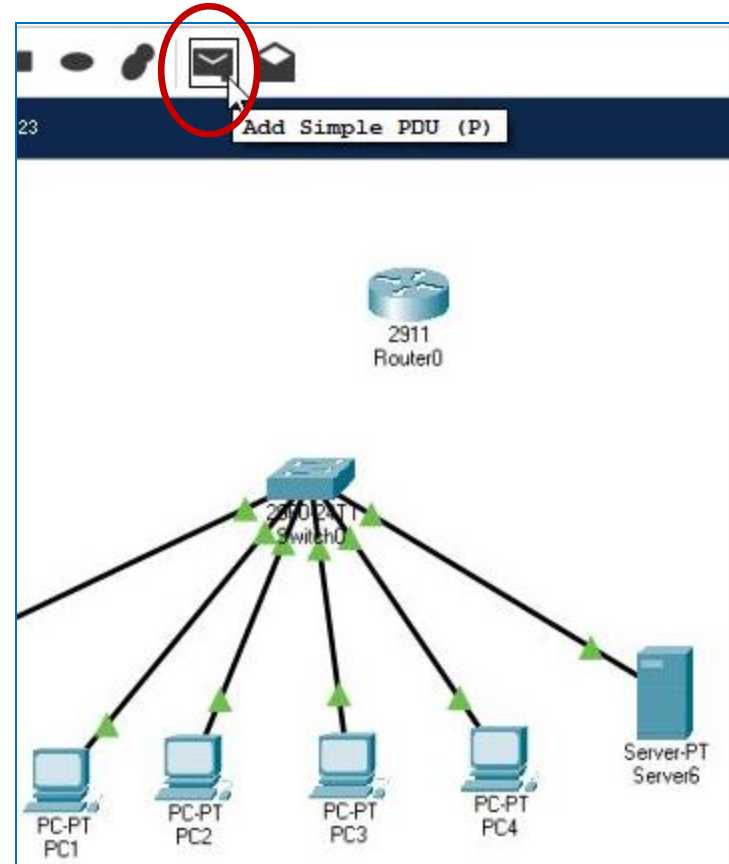



The simple LAN and Simulation Mode

- **Protocol Data Unit (PDU)**

- A protocol data unit is a specific block of information delivered sent between network connected devices. It containing control information, source information and destination information.
- PDU is related to the first 4 layers of the OSI model. In Layer 1, PDU is a bit, in Layer 2 it is a frame, in Layer 3 it is a packet and in Layer 4 it is a segment. In Layer 5 and above a PDU is referred to as data.

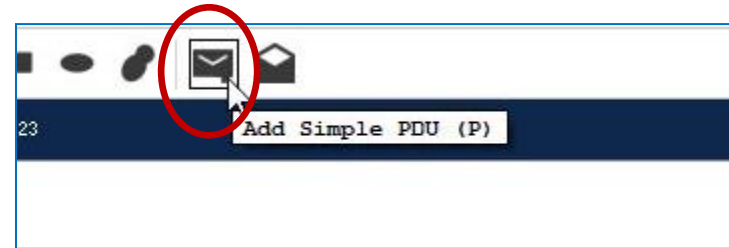



The simple LAN and Simulation Mode

- *After clicking on Add Simple PDU*
 - Click on a **source device** for the PDU

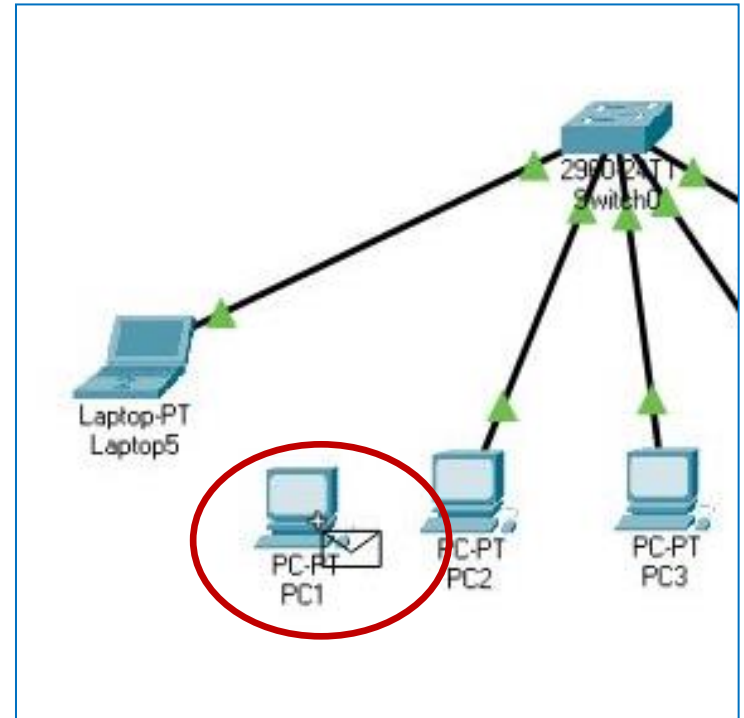



The simple LAN and Simulation Mode

- *After clicking on Add Simple PDU and selecting a source device*
 - Click on another device which will be the **destination device** for the PDU

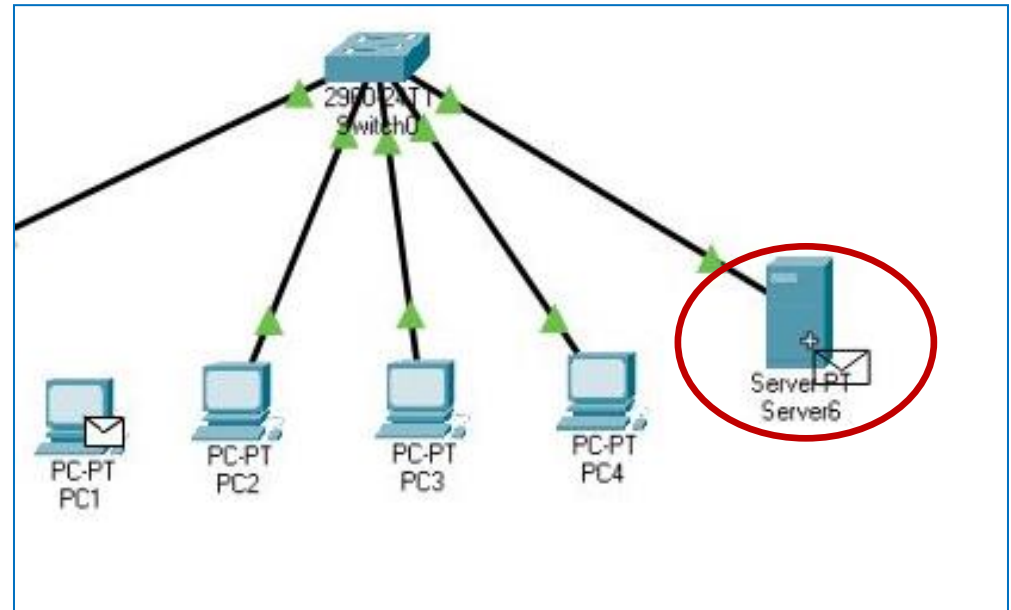



The simple LAN and Simulation Mode

- When using a Simple PDU, the **Created Packet Window** will indicate:
 - **Successful**, if the PDU has been sent successfully over the network
 - **Failed**, if the PDU has not been sent indicating a problem with the network
 - This could be wrong IP address setting
 - A device is turned off and unreachable
 - A router has wrong configuration settings
 - **In Progress**, the status when a PDU is moving from a source to destination device in Simulation Mode

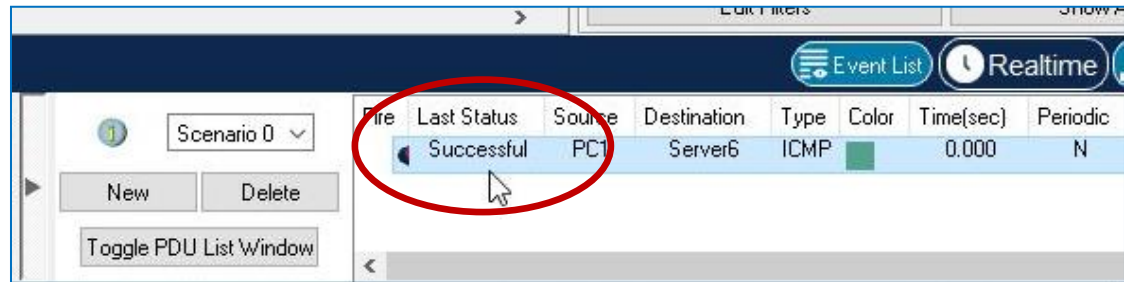



The simple LAN and Simulation Mode

- Using the Scenarios subsection of the **Created Packet Window**:
 - Click on PDU event (right side), A PDU event will be highlighted in blue when selected
 - Click on the **Delete** button, this will remove the PDU event
 - This can be useful for testing one PDU event at a time, i.e. using a Simple PDU yet again for another source and destination

The screenshot shows the 'Created Packet Window' in a network simulation software. At the top, there is a list of protocols including ICMP, OSPF, POP3, PPP, etc. Below this is a table of PDU events. The first row is highlighted in blue and circled in red. The 'Delete' button is also circled in red. A tooltip is visible over the 'Delete' button, indicating the action: 'Delete Scenario and All PDUs (Ctrl+Shift+E)'.

File	Last Status	Source	Destination	Type	Color	Time(sec)	Periodic	Num	Edit	Delete
	Successful	PC1	Server5	ICMP	Green	0.000	N	0	(edit)	(delete)



The simple LAN – PDU status in Realtime Mode

- Click on **Realtime Mode** to return to Realtime Mode (and hide the Simulation Mode section)
- Click on the **Add Simple PDU**, then click on a source and destination device
 - Note that the *Created Packet Window* will still indicate **Successful** or **Failed** for the PDU sent (even though the workspace will not show the PDU moving from device to device like with Simulation Mode)

Fire	Last Status	Source	Destination	Type	Color	Time(sec)	Periodic	Num	Edit	De
	Successful	PC3	PC4	ICMP		0.000	N	0	(edit)	(de

The diagram shows a network topology with three devices: PC-PT PC3, PC-PT PC4, and Server-PT Server6. PC3 and PC4 are connected to each other and to Server6. The 'Realtime' mode button is circled in red, and the 'Successful' status in the table is also circled in red.

This can be useful for checking the network connectivity in Realtime Mode



Connecting 2 Local Area Networks (LANs)

- Add a second **2911 Router** to the workspace
 - *(see Slide 36 for adding a router)*

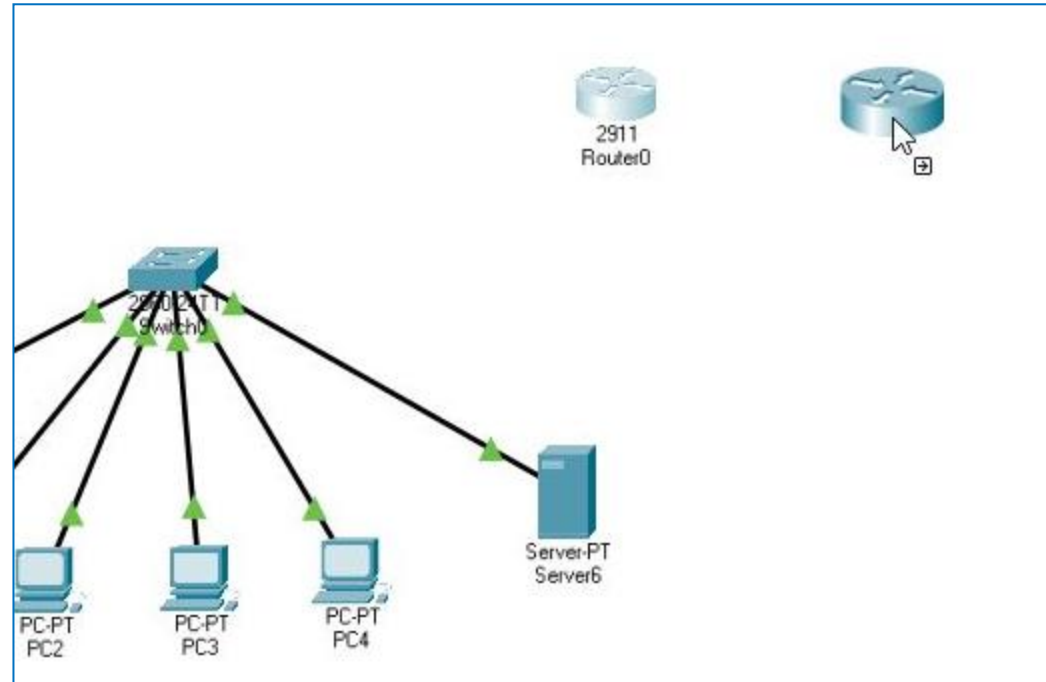



Connecting 2 Local Area Networks (LANs)

- Create a second LAN in the workspace
 - Add 3 PCs, 1 Server and 1 2960 Switch to the workspaceand connect them using Straight through cables (connecting through the Fast Ethernet ports)

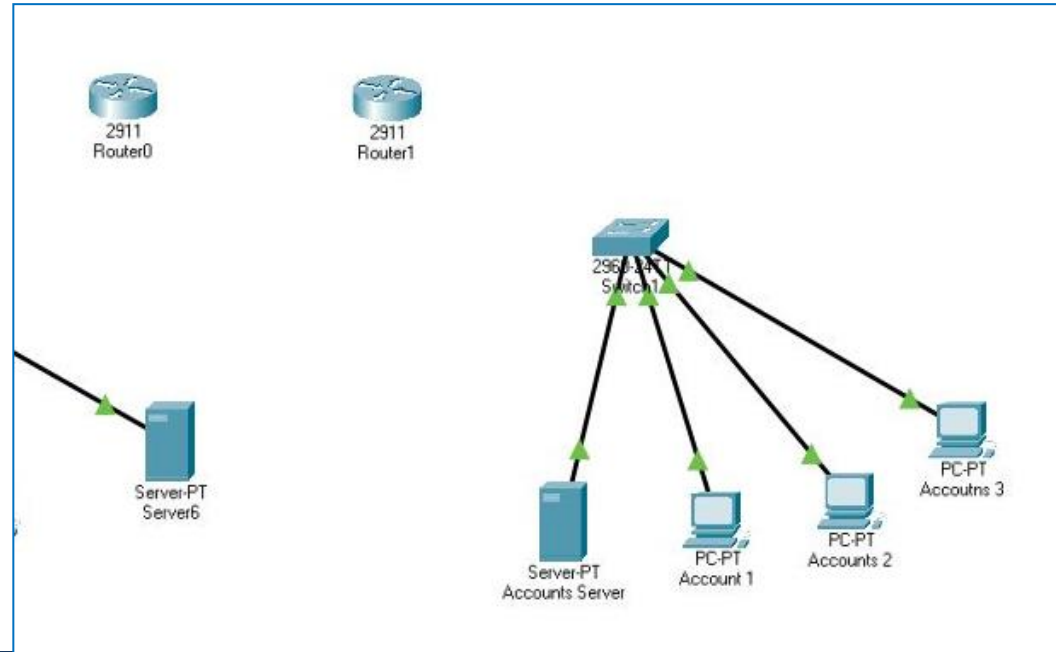



Connecting 2 Local Area Networks (LANs)

- For the second LAN in the workspace, give the devices Display Names and IP addresses (using a class B network)
- PC Accounts 1:
 - IP: **172.168.10.11**
 - Subnet mask: **255.255.0.0**
 - Gateway: **172.168.10.1**

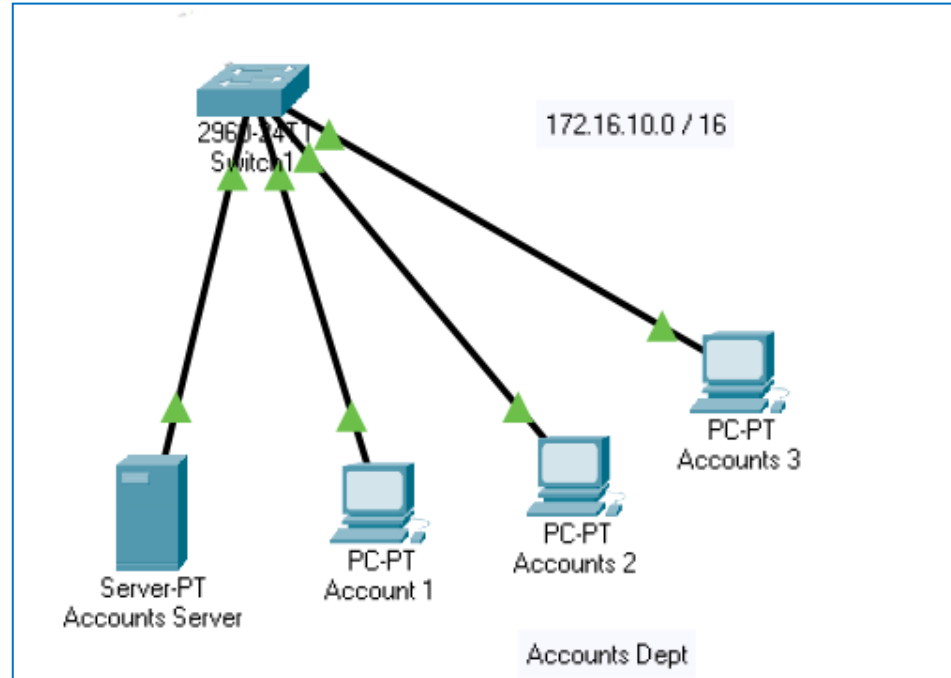



Connecting 2 Local Area Networks (LANs)

- Display Names and IP addresses for the 2nd LAN
- PC Accounts 2 :
 - IP: **172.168.10.12**
 - Subnet mask: **255.255.0.0**
 - Gateway: **172.168.10.1**
- PC Accounts 3:
 - IP: **172.168.10.12**
 - Subnet mask: **255.255.0.0**
 - Gateway: **172.168.10.1**

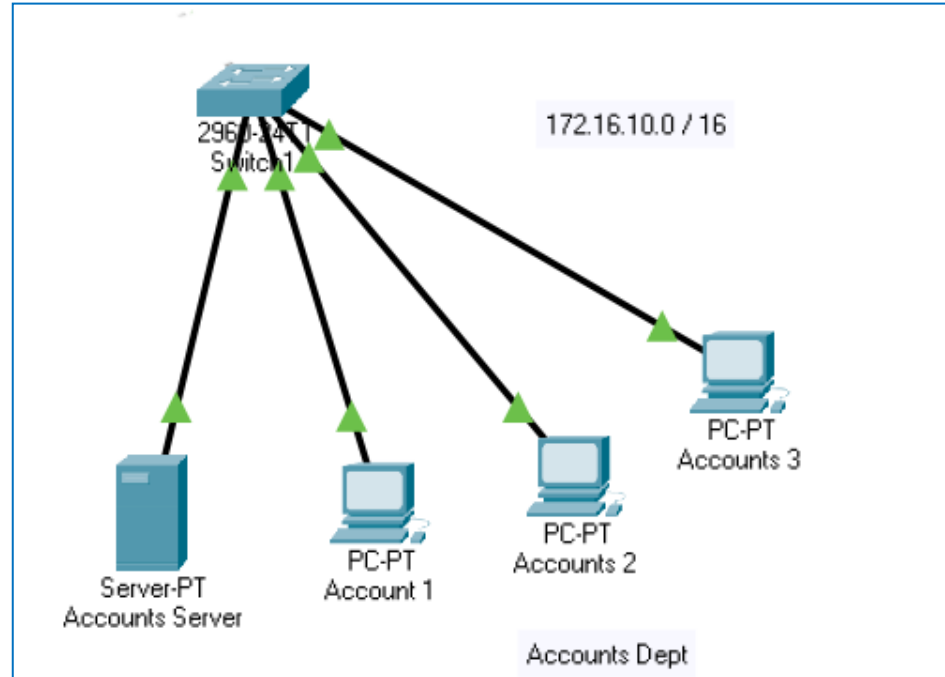



Connecting 2 Local Area Networks (LANs)

- Display Names and IP addresses for the 2nd LAN (cont.)
- Accounts Server:
 - IP: **172.168.10.14**
 - Subnet mask: **255.255.0.0**
 - Gateway: **172.168.10.1**

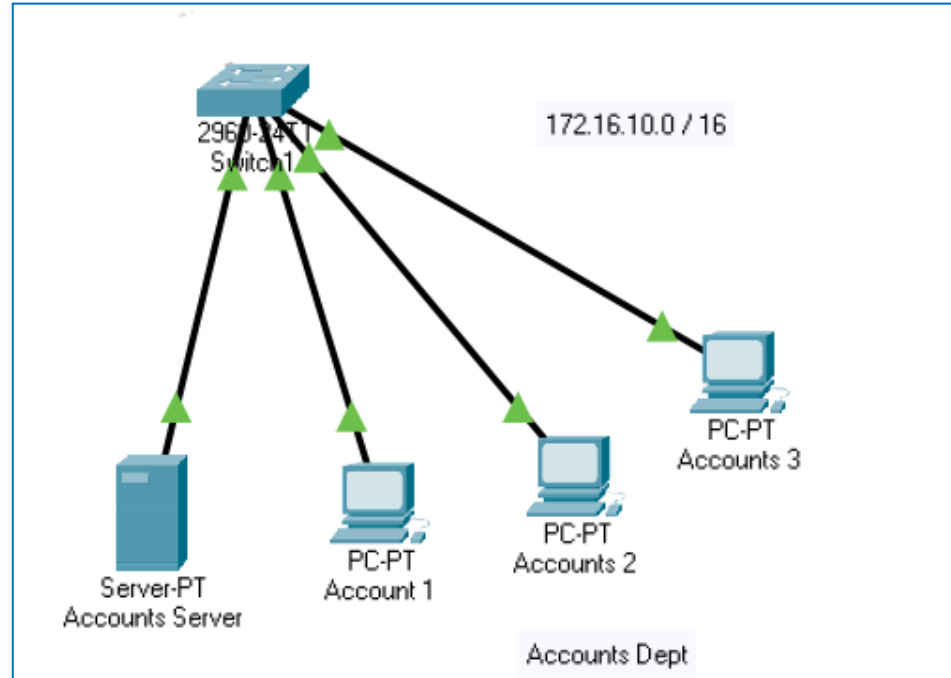

The Default Gateway will be the IP address of the router

Connecting 2 Local Area Networks (LANs)



- Rename the Display Names of the two routers (*an extra step, not a must for the network to function*)
 - named **Router ICT** for the 1st router
 - **Router AC** for the 2nd router

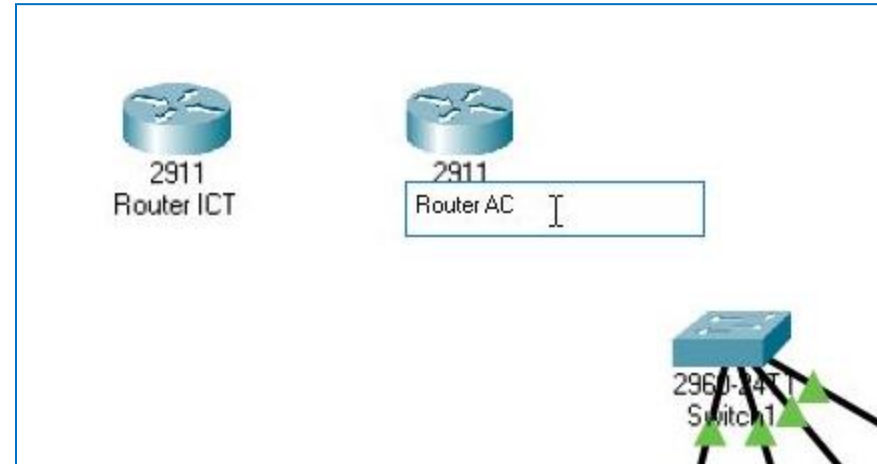



Connecting 2 Local Area Networks (LANs)

- Using a straight through cable, connect the 2nd LAN's Switch to Router AC
 - Connect the switch's **GigabitEthernet0/1** port to the router's **GigabitEthernet0/1** port

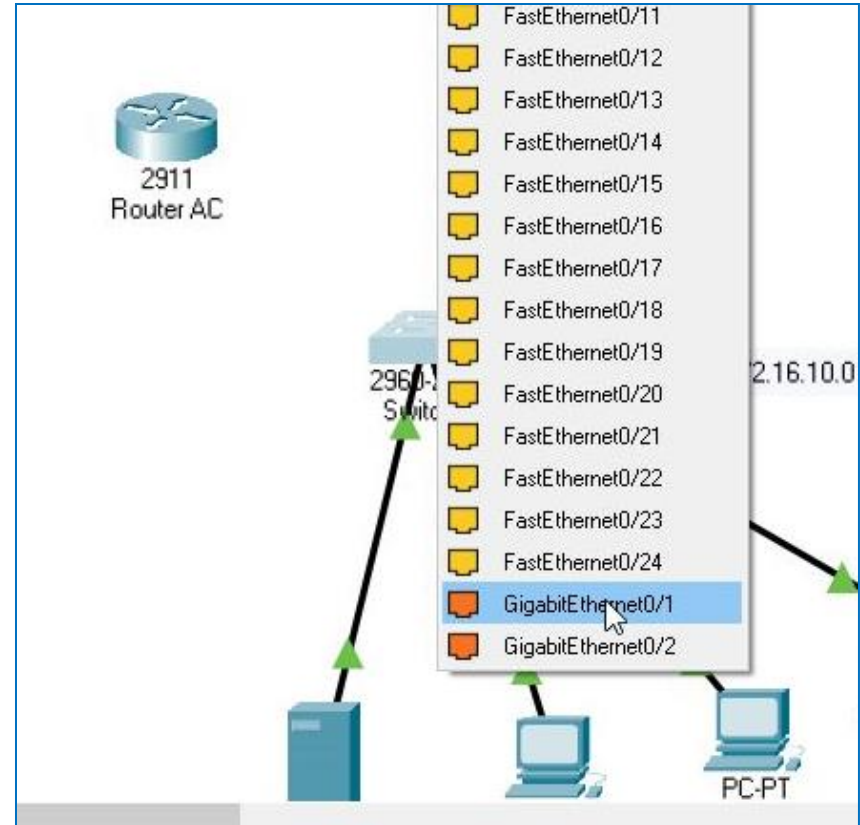



Connecting 2 LANs

- Using a straight through cable, connect the 2nd LAN's Switch to Router AC
 - Connect the switch's **GigabitEthernet0/1** port to the router's **GigabitEthernet0/1** port

The names of these ports will be required when configuring the router. Note that any GigabitEthernet port (number) can be used, however for consistency **GigabitEthernet0/0** will be **reserved** for connecting the two routers together (i.e. Gig0/0 connecting to another Gig0/0 port on the other router)

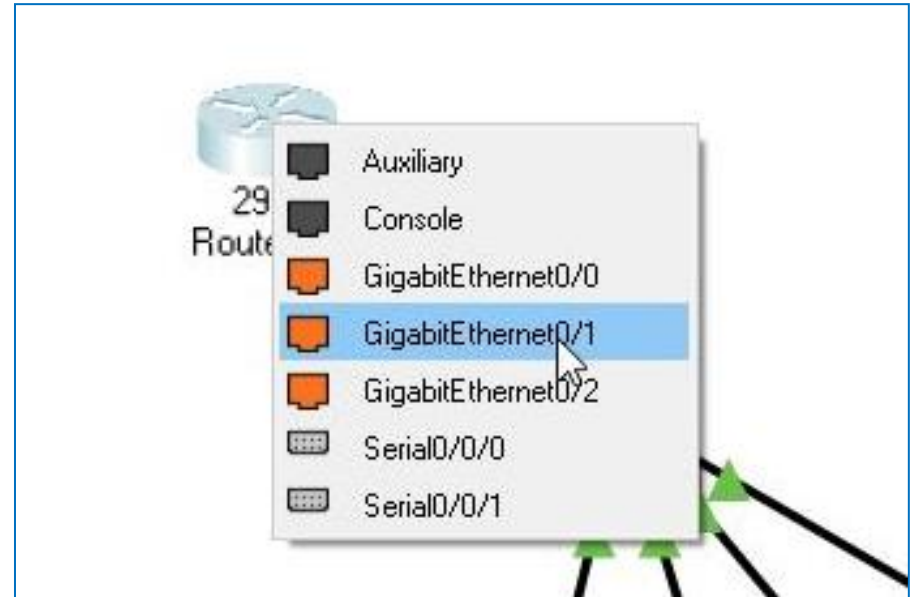



Connecting 2 LANs

- After the straight through cable has been connected from the switch to the router, note that the connection is indicated in **red**
 - The network connection is not (yet) successful as the router has not yet been configured
 - e.g. the router does not have an IP address

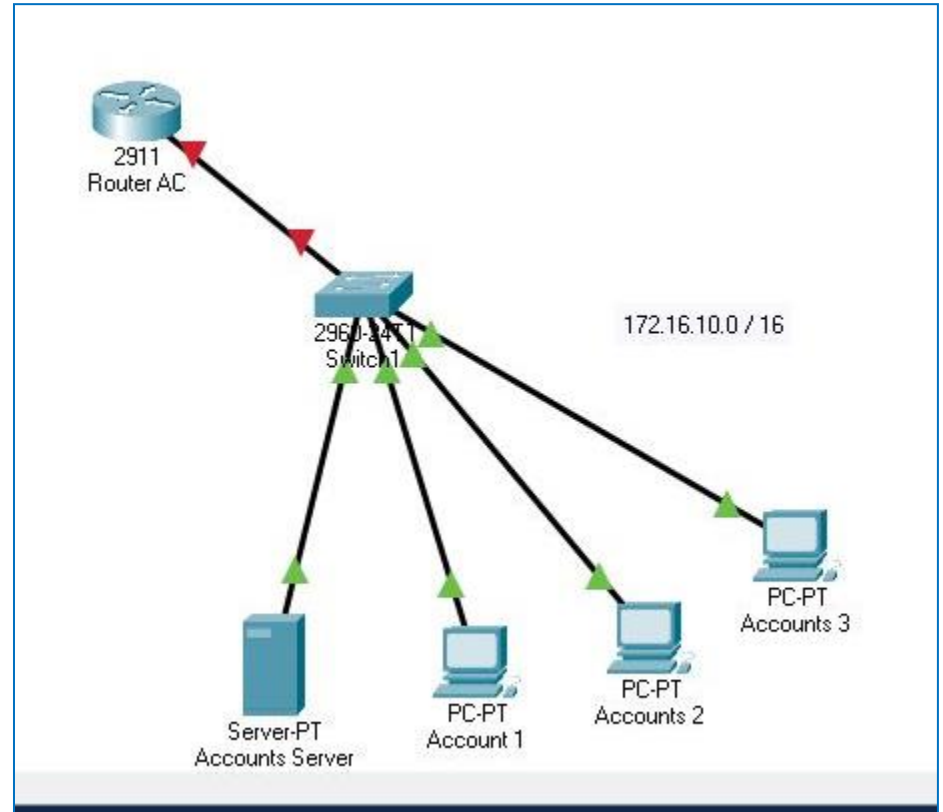



Connecting 2 LANs

- Using a straight through cable, connect the 1st LAN's Switch to Router ICT
 - Connect the switch's **GigabitEthernet0/1** port to the router's **GigabitEthernet0/1** port

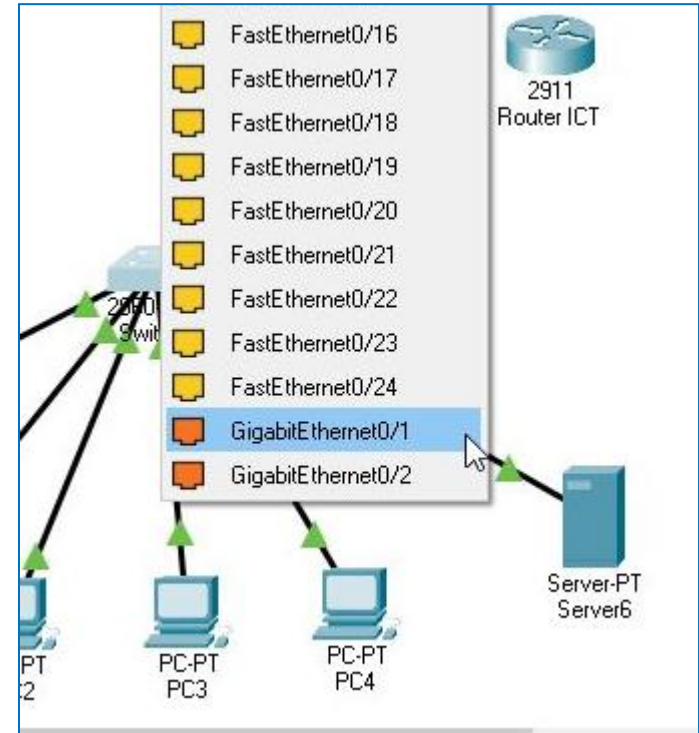



Connecting 2 LANs

- Connect the 1st LAN's switch to Router ICT (cont.)

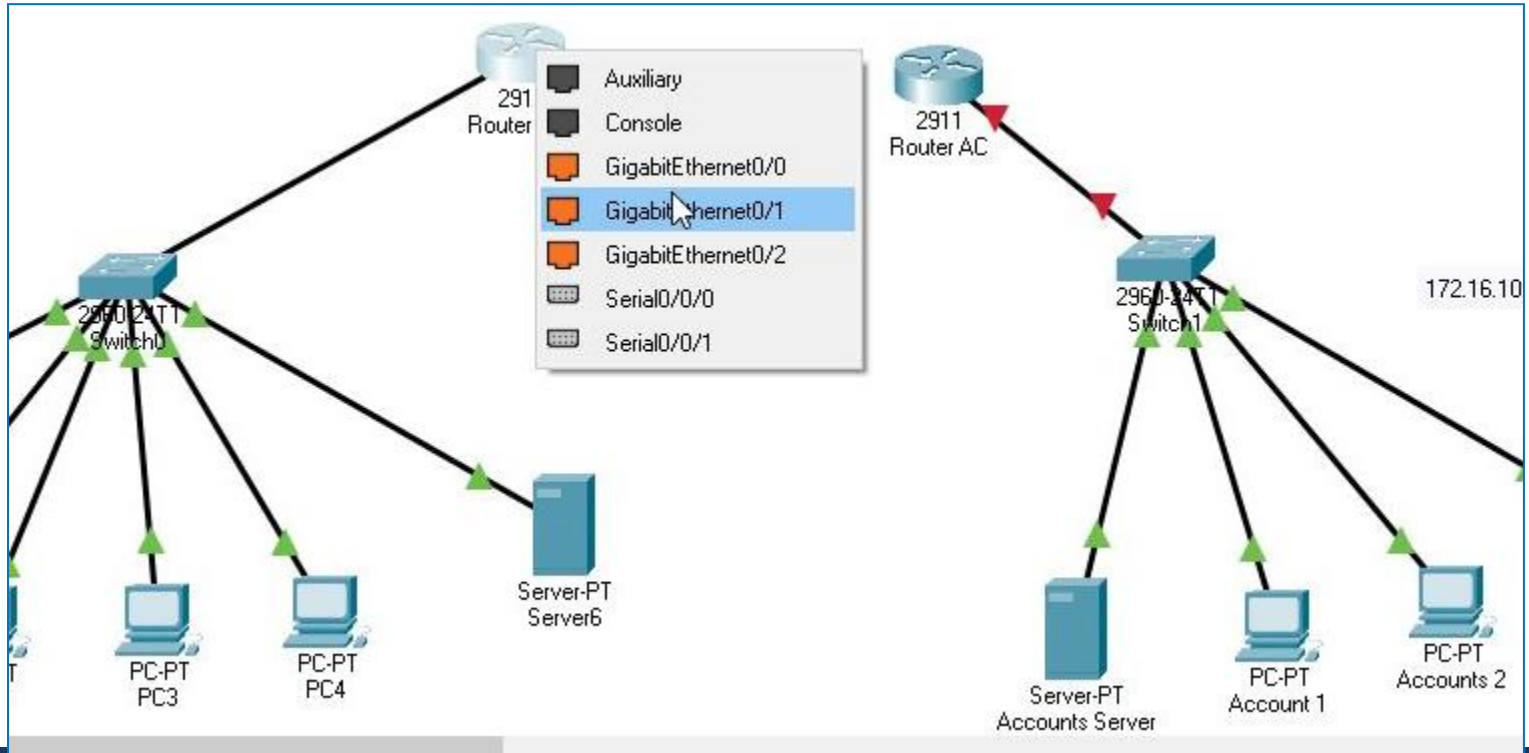



Connecting 2 LANs

- Once again the connection will not yet be successful before Router ICT has been configured

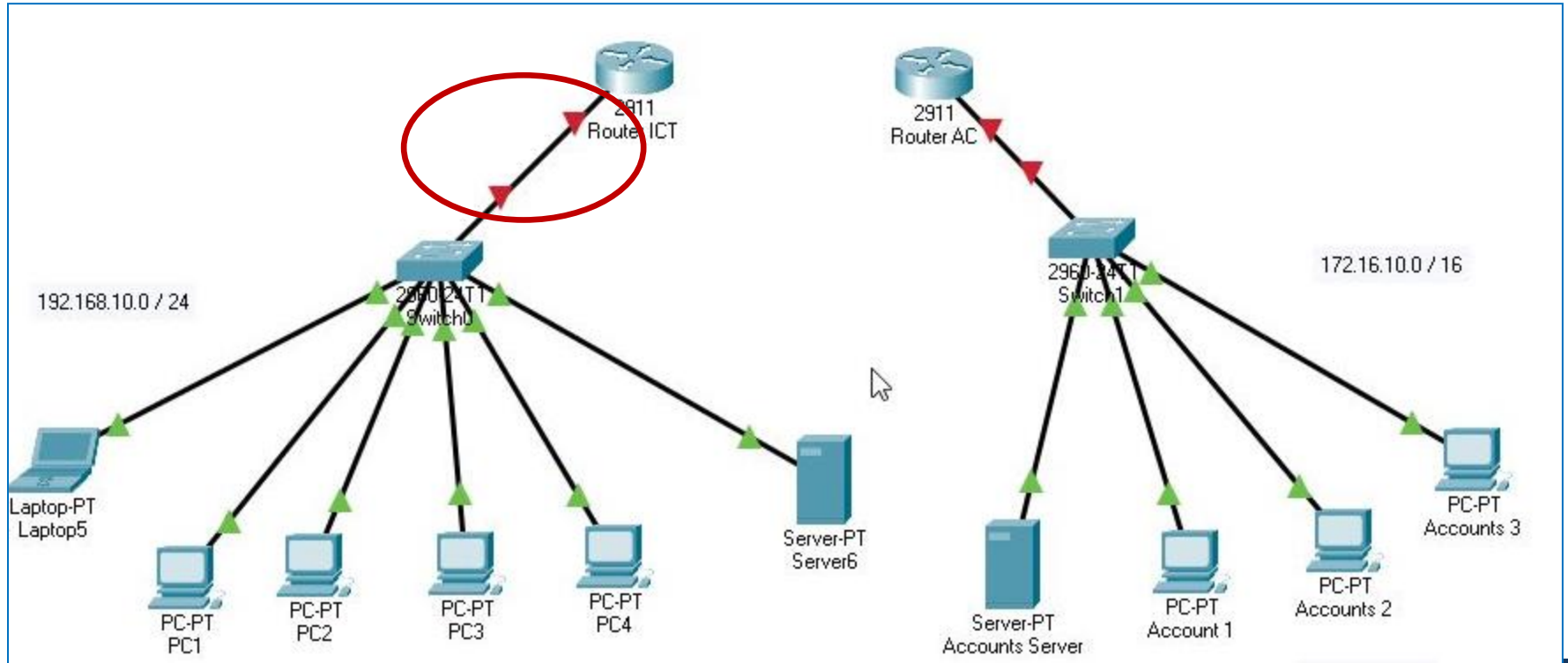

Connecting 2 LANs

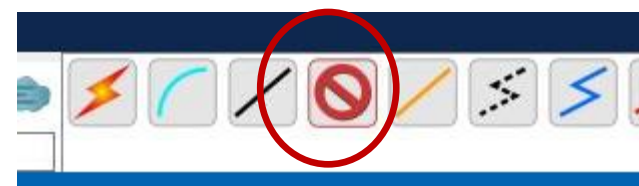

- Now connect Router ICT to Router AC using **Crossover** cable
 - (recap: straight through cables are used for different devices whereas crossover cables are used to similar devices, i.e. 2 routers)

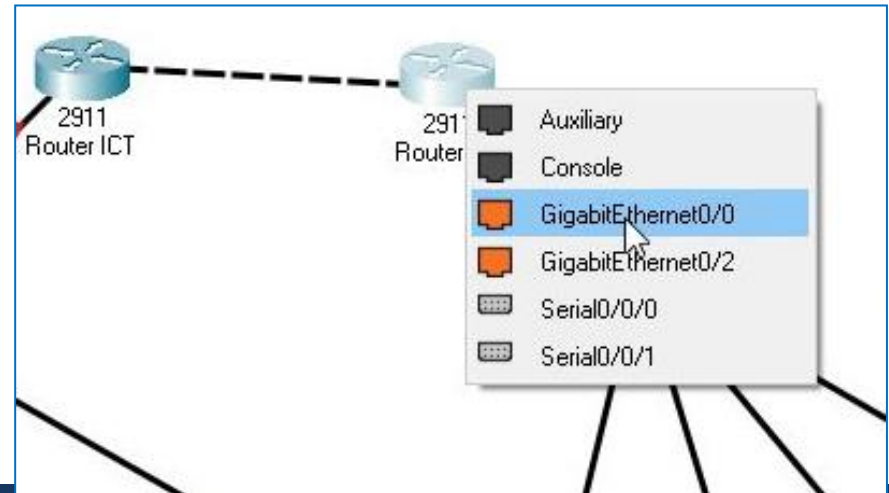
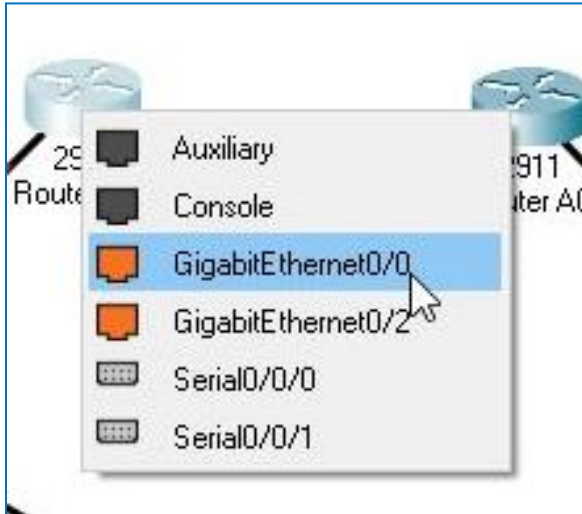



Connecting 2 LANs

- Now connect Router ICT to Router AC using **Crossover** cable
 - Connect the **GigabitEthernet0/0** port of Router ICT to the **GigabitEthernet0/0** port of Router AC

Note that **GigabitEthernet0/0** can also be referred to as **Gig0/0** (which is how it will be written in following slides)

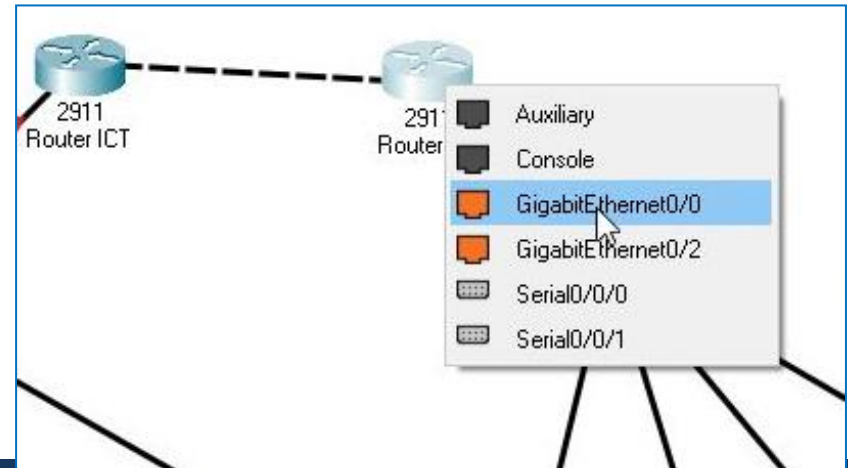
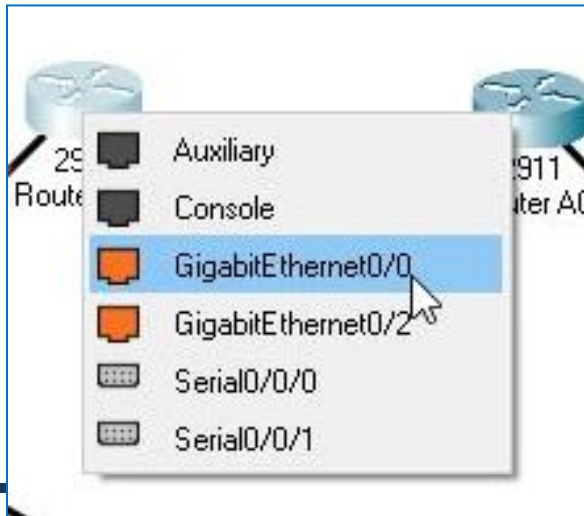



Connecting 2 LANs

- Now all the cable connections are completed for connecting the 2 LANs together, however the routers still need to be configured
- The routers can be configured using **router commands**

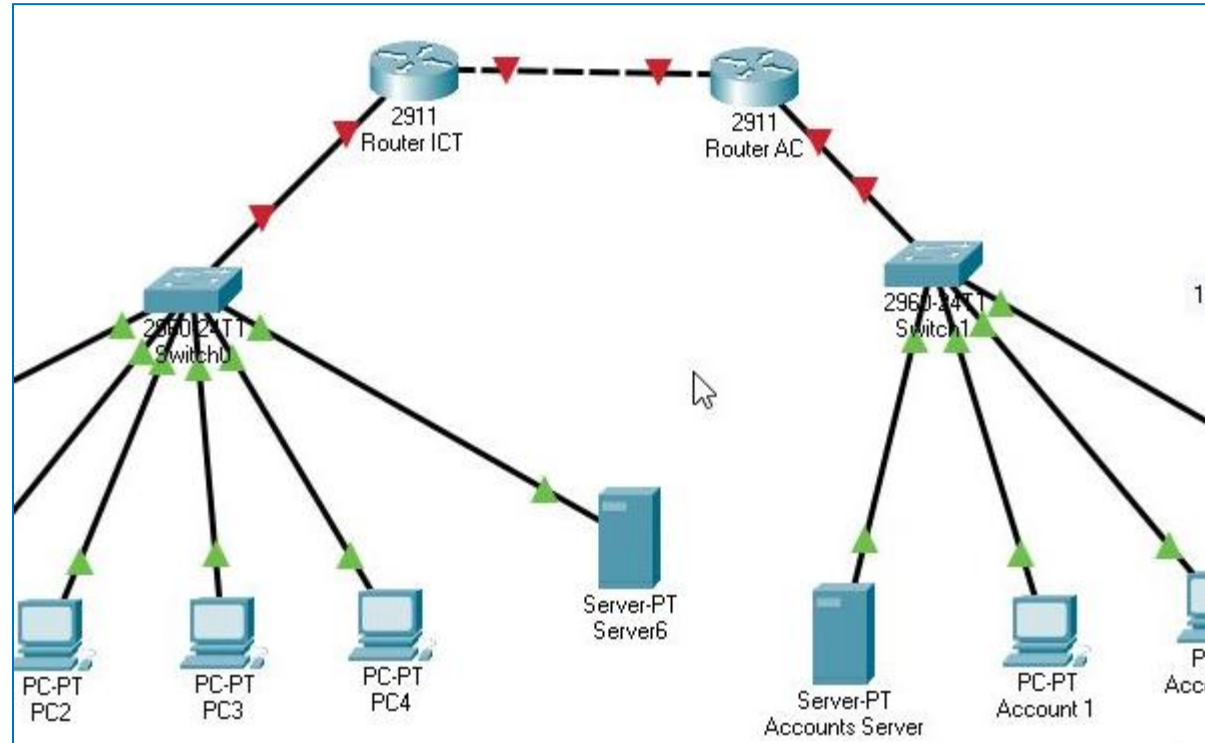



Connecting 2 LANs

- *Preparing to use router commands from a router's **Command Line Interface (CLI)***
 - The font size of a router's CLI can be adjusted within Packet Tracer:
 - Click **Options** (from the main menu)
 - > click on **Preferences** option
 - > click on the **Font** table
 - > click on the **font size dropdown** (next to the CLI label), **choose a larger or smaller font size (based on personal preference)**
 - > click **Apply**

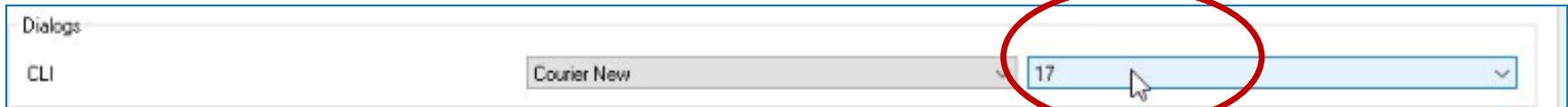
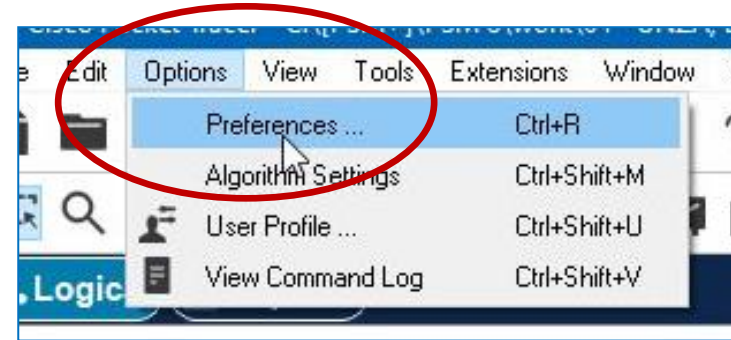



Connecting 2 LANs

- Hover the mouse over a cable connection and the interfaces/ports connected will be indicated
 - The port names will be used with router commands when configuring the routers

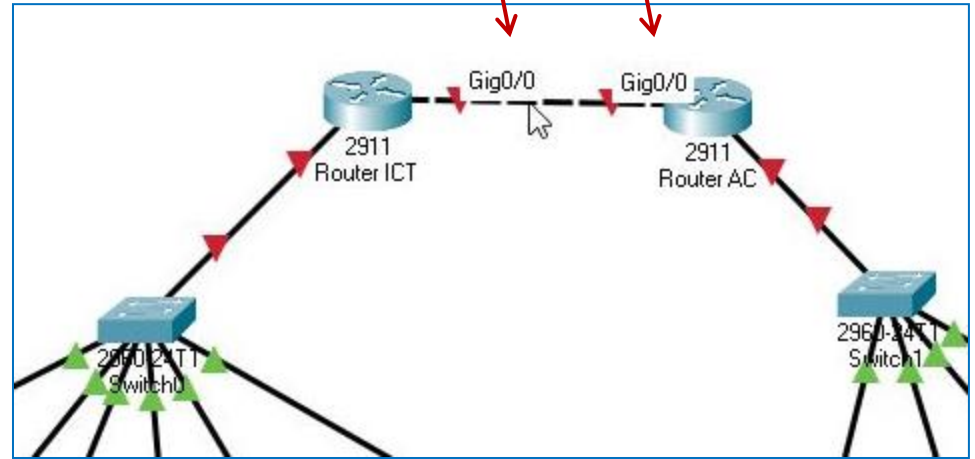

Connecting 2 LANs – Basic Router Commands



Router command	Description
<code>enable</code>	logs a user in from <i>user mode</i> into <i>privileged mode</i>
<code>configure terminal</code>	enables access to <i>global configuration mode</i>
<code>hostname</code>	allows user to change the name of the router
<code>enable password</code>	allows user to change the password of a router
<code>interface</code>	switches a user into <i>interface mode</i>
<code>ip address</code>	allows a user to set an IP address when in <i>interface mode</i>
<code>no shutdown</code>	turns an interface on
<code>shutdown</code>	turns an interface off (shuts down a specific port)

Connecting 2 LANs – Basic Router Commands



Router command	Description
<code>show ip route</code>	shows the routing table of the router (i.e. all the networks the router can forward packets to)
<code>ip ospf</code>	allows the router to find (identify) other routers' networks which will be added to the router's routing table

Note that there are several other router commands, we will focus on basic router commands for connecting two LANs together (i.e. connecting two networks together)

Connecting 2 LANs – Basic Router Commands



- Configuring a router through basic router commands, objectives:
 - Set IP addresses for the two routers' interfaces
 - Turning on the router interfaces (off by default)
 - Allow data (packets) to be transmitted from a device on LAN 1 to a device on LAN 2

Connecting 2 LANs – Basic Router Commands



- Configuring a router through basic router commands:
 - Click on Router ICT to bring up its **device properties**
 - Click on the **CLI** tab to go to the Command Line Interface (CLI)

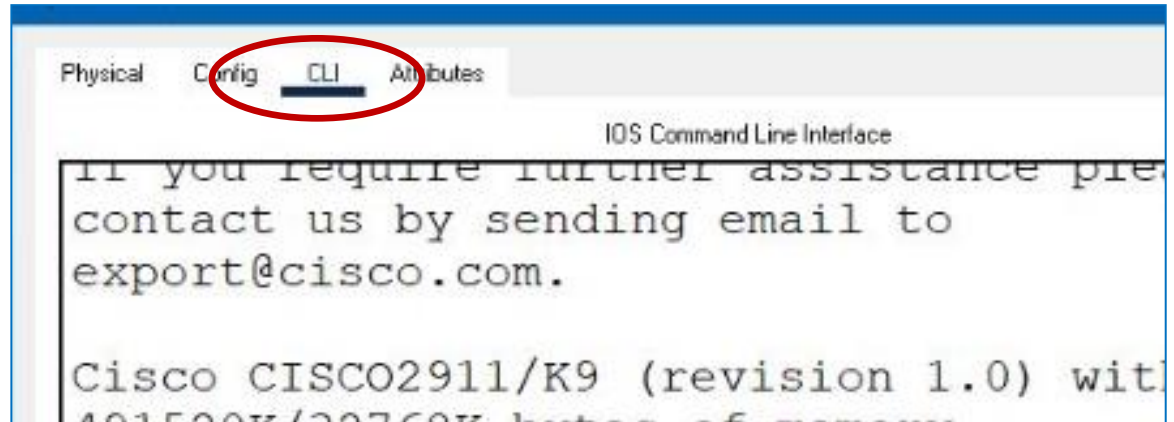



Router Commands – Entering the CLI for the first time

- Upon entering a router's CLI for the first time, an option for an initial configuration will be presented
 - Type in **no** and hit enter, hit enter again
 - You will now have access to entering in router commands on the router

Note that the initial configuration dialog includes configuring aspects of the router beyond our scope (connecting two basic LANs) hence why **no** is used

```
--- System Configuration Dialog ---  
  
Would you like to enter the initial  
configuration dialog? [yes/no]: no  
  
Press RETURN to get started!  
  
Router>
```





Connecting 2 LANs

- **Enable** command
 - Allows the user to enter *Privileged Mode*
- From *User Mode* (the first router mode by default), type in `enable` and hit enter to enter *Privileged Mode*
 - *Privileged Mode* allows for more router settings' changes that *User Mode* does not allow

syntax:
`enable`
or
`en`

```
Press RETURN to get started!
```

```
Router>enable| I
```

Connecting 2 LANs



- *User Mode* can be identified by the **angular bracket (>)** next to the router's name
- *Privileged Mode* can be identified by the **hashtag (#)** next to the router's name

```
Router>enable
Router#|
```



Connecting 2 LANs

- **Configure terminal** command
 - Allows the user to enter *Global Configuration Mode*
- From *Privileged Mode* type in `conf t` and hit enter to enter *Global Configuration Mode*

syntax:
`configure terminal`
or
`conf t`

- *Global Configuration Mode* is identified by the word (config) next to the router's name

```
Router>enable
Router#conf t
Enter configuration commands,
End with CNTL/Z.
Router(config)# I
```





Connecting 2 LANs

- **Hostname** command
 - Allows the user to change the name of the router
 - (not to be confused with the router's Display Name in the workspace (which is specific to Packet Tracer))
- Type in `hostname RouterICT` and hit enter to change the name of the router

syntax:
`hostname name`

```
END WITH CTRL/Z.  
Router(config)#hostname RouterICT  
RouterICT(config)#
```



Connecting 2 LANs

- **Enable password** command
 - Allows the user to set a password of the router
 - Once a password has been set, it will be required when changing from *User Mode* into *Privileged Mode*

syntax:

```
enable password password
```

- Type in `enable password ict` and hit enter to make ict the password of the router

```
RouterICT (config) #enable password ict
RouterICT (config) #
```



Connecting 2 LANs

- **Exit** command
 - Used to go back to a previous mode (when necessary)
 - ie entering the exit command from *Configuration Mode* will return the user to *Privileged Mode*

syntax:
exit

```
RouterICT(config)#enable password ict
RouterICT(config)#exit
RouterICT#
%SYS-5-CONFIG_I: Configured from console by
console
RouterICT#
```



Connecting 2 LANs

- **Exit command and Router Modes**

There are 4 router modes in our scope (for connecting 2 LANs together), the `exit` command can be used to return to a previous mode

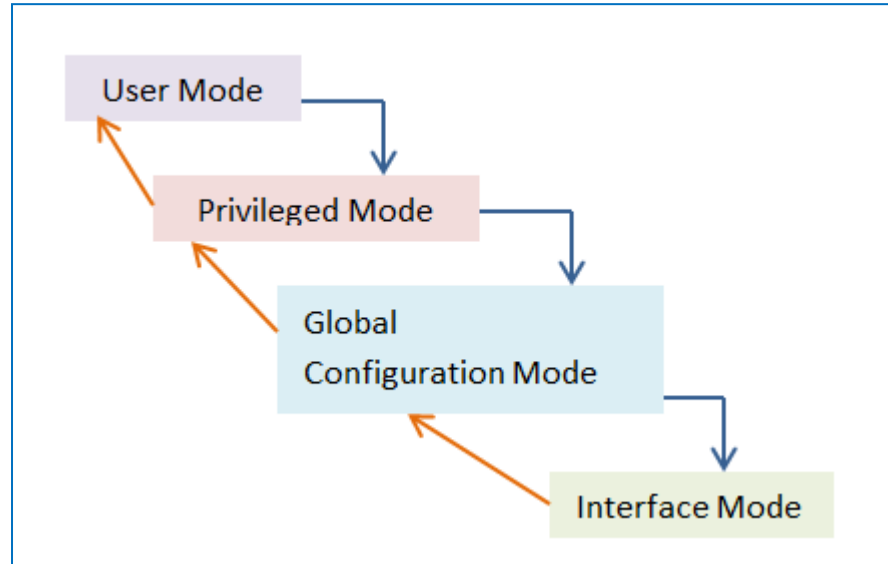

Note: mode changes from the `exit` command are represented with the orange arrows



Connecting 2 LANs

- Exit command and Router Modes

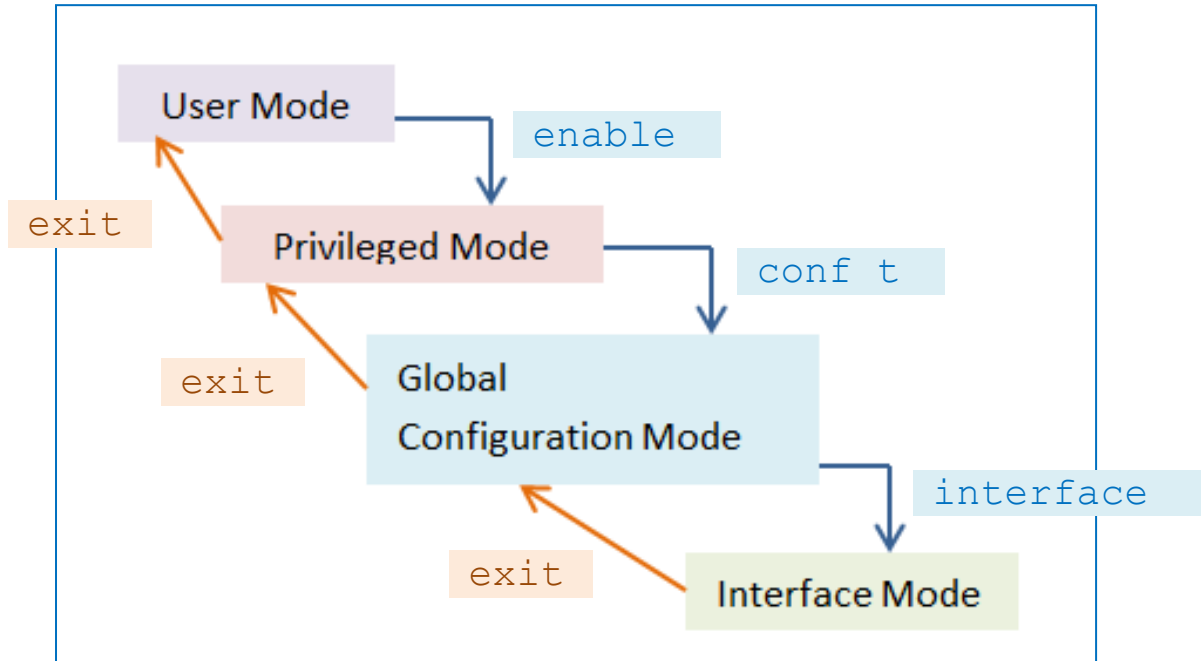



Connecting 2 LANs

After setting a password

- back in *User Mode*, the user will now be required to enter a password in order to enter *Privileged Mode*

```
RouterICT>enable  
Password:  
RouterICT#
```

Note that password characters will not be displayed, i.e. for this router the user will have to type in `ict` and hit enter even though `ict` will not be displayed



Connecting 2 LANs

- **Interface** command
 - Used to go from *Global Configuration Mode* into *Interface Mode* **for a specific interface (port)**

syntax:

```
interface interface_name
```

- *Interface Mode* is identified by the word (config-if) next to the router's name
- in *Global Configuration Mode*
 - type in `interface Gig0/1` to enter *Interface Mode* for the Gig0/1 interface (i.e. the connection between Router ICT and the LAN 1 switch)

```
RouterICT (config) #interface Gig0/1  
RouterICT (config-if) #
```

Connecting 2 LANs

- **IP Address** command
 - Used to set an IP Address for **specific interface** *in Interface Mode*

syntax:

```
ip address ip_address subnet_mask
```

```
RouterICT(config)#interface Gig0/1  
RouterICT(config-if)#ip address 192.168.10.1 255.255.255.0
```

Gig0/1 interface

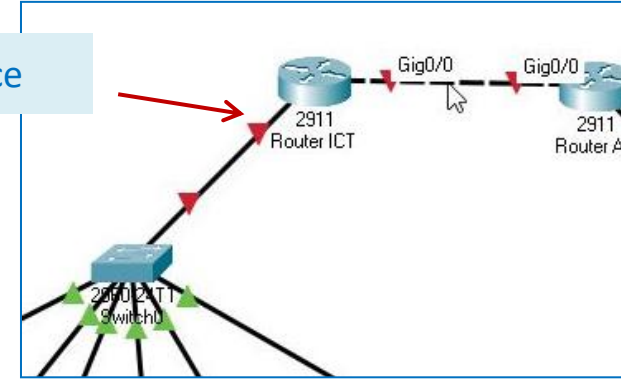



Connecting 2 LANs

- **IP Address** command (cont.)
 - in Interface Mode
 - `type in ip address 192.168.10.1 255.255.255.0` to set an IP address and subnet mask on Router ICT's Gig0/1 interface (i.e. the connection between Router ICT and the LAN 1 switch)
 - The IP address for port Gig0/1 (port connected to the switch) should be on the same network (192.168.10.0) as the other devices on LAN 1

```
RouterICT(config)#interface Gig0/1  
RouterICT(config-if)#ip address 192.168.10.1 255.255.255.0
```



Connecting 2 LANs

- **IP Address** command (cont.)

- Note that an IP address has to be set for the **Gig0/0** interface as well in order for the two LANs to be connected

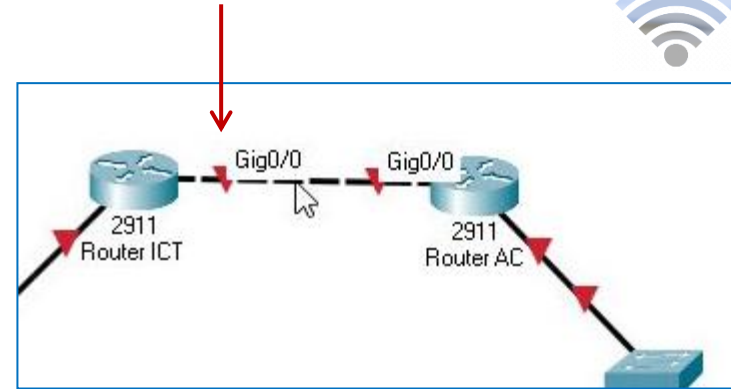

- The connection between the routers is regarded as its own network, this network can use a subnet with few hosts as it will only require **2 hosts** (the two routers)

- i.e. there will be 3 networks connected together, LAN 1, LAN 2 and connection between the routers



Connecting 2 LANs

- **IP Address** command (cont.)

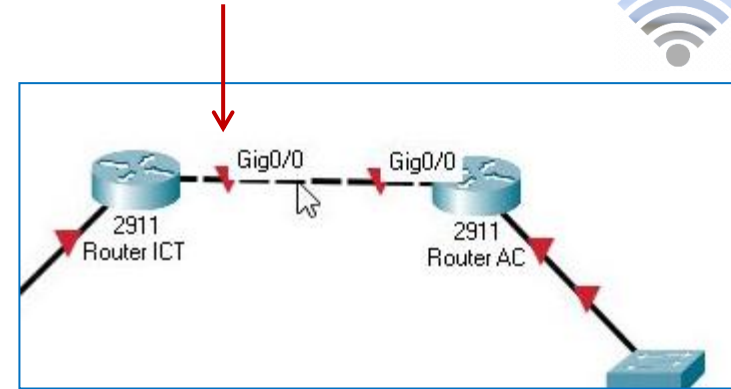

– in Interface Mode (or Global Configuration Mode)

- type in `interface Gig0/0` to enter Interface Mode for interface Gig0/0
- type in `ip address 201.5.5.1 255.255.255.252` to set an IP address for interface Gig0/0

```
RouterICT(config-if)#interface Gig0/0
RouterICT(config-if)#ip address 201.5.5.1 255.255.255.252
```



Connecting 2 LANs

- **IP Address** command (cont.)

```
RouterICT(config-if)#interface Gig0/0  
RouterICT(config-if)#ip address 201.5.5.1 255.255.255.252
```

- This will be a class C network (**201.5.5.0 /30**) whereby (due to Subnetting) only 2 hosts can be set. i.e. only 4 host addresses are available (two of which are reserved)
 - 201.5.5.0 reserved as the network address
 - 201.5.5.1 can be set to a host (*Router ICT's Gig0/0 port*)
 - 201.5.5.2 can be set to a host (*Router AC's Gig0/0 port*)
 - 201.5.5.3 reserved as the broadcast address

201.5.5.4 is not available, for a /30 network, this is the network address of another subnet / network



Connecting 2 LANs

IP Address command (cont.)

- Hover the mouse over a router to view information about the router's ports
- After setting IP addresses from the router's CLI, the Gig0/1 and Gig0/0 interfaces should now indicate the IP addresses set

In the router's Interface Mode, enter the IP address command again to change an IP address (when necessary)

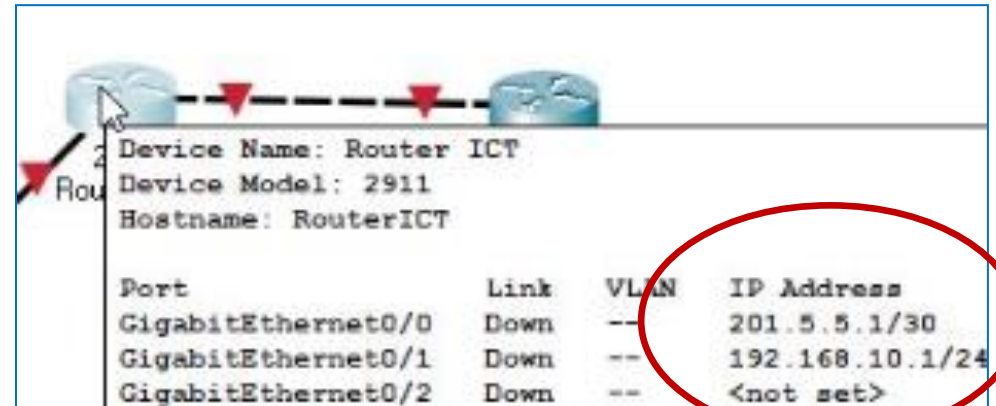

Port	Link	VLAN	IP Address
GigabitEthernet0/0	Down	--	201.5.5.1/30
GigabitEthernet0/1	Down	--	192.168.10.1/24
GigabitEthernet0/2	Down	--	<not set>



Connecting 2 LANs

- **No shutdown** command
 - Used to turn on an interface (by default router interfaces will be set to 'down', no shutdown will set an interface's status to 'up')

syntax:
no shutdown

```
RouterICT(config)#interface Gig0/0
RouterICT(config-if)#no shutdown

RouterICT(config-if)#
%LINK-5-CHANGED: Interface
GigabitEthernet0/0, changed state to up
```



Connecting 2 LANs

- **No shutdown** command (cont.)
- The `no shutdown` command has to be set for each interface (Gig0/0 and Gig0/1) individually
 - Enter Interface Mode for interface Gig0/0
 - type in `no shutdown` and hit enter

 - Enter Interface Mode for interface Gig0/1
 - type in `no shutdown` and hit enter

 - Both interfaces will now be set to **up** (on)

```
RouterICT(config-if)#interface Gig0/1
RouterICT(config-if)#no shutdown
```



Connecting 2 LANs

- **No shutdown** command (cont.)
 - Note: now that the Gig0/1 interface has been given an IP address and set to up, the connection between the router and the switch will be successfully connected

- The connection between the 2 routers is not yet successful since Router AC has not yet been configured

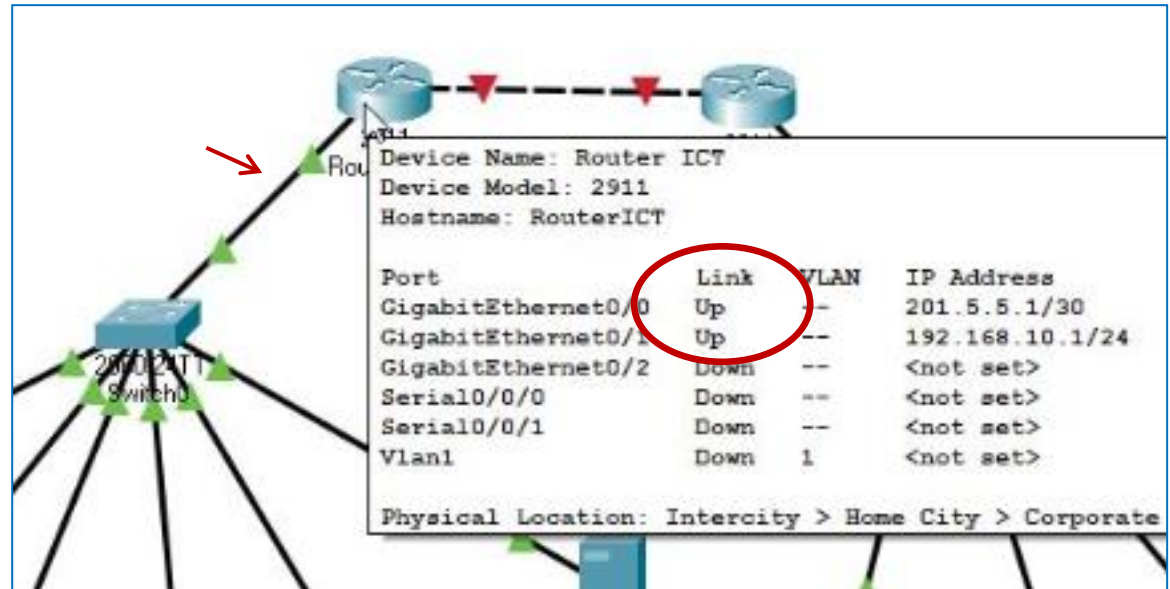

Connecting 2 LANs



- In order to connect the two LANs
 - Configure the 2nd router, Router AC, using the similar commands from Router ICT

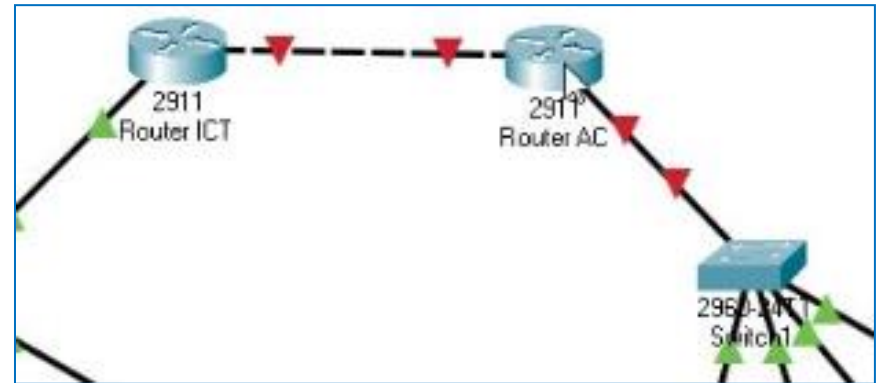



Connecting 2 LANs

- open **device properties** for Router AC
 - click on the **CLI** tab
 - type and enter `no` for the initial configuration
 - type in and enter `enable` (or `en`) to enter *Privileged Mode*
 - type in and enter `conf t` to enter *Global Configuration Mode*
 - type in and enter `hostname RouterAC` to change the name of the router

```
Router>en
Router#conf t
Enter configuration commands, one per line.  End with CNTL/Z.
Router(config)#hostname RouterAC
RouterAC(config)#interface Gig0/1
RouterAC(config-if)#ip address 172.16.10.1 255.255.0.0
RouterAC(config-if)#no shutdown
```

Connecting 2 LANs



- **Setting up IP addresses for a second router (Gig0/1)**
- *In Global Configuration Mode:*
 - type in and enter `interface Gig0/1` to enter *Interface Mode* for the Gig0/1 interface
 - type in and enter `ip address 172.16.10.1 255.255.0.0` to set an IP address for interface Gig0/1
 - type and enter `no shutdown` to set the interface status to up

```
Router#conf t
Enter configuration commands, one per line.  End with CNTL/Z.
Router(config)#hostname RouterAC
RouterAC(config)#interface Gig0/1
RouterAC(config-if)#ip address 172.16.10.1 255.255.0.0
RouterAC(config-if)#no shutdown
```

Connecting 2 LANs



- **Setting up IP addresses for a second router (Gig0/1)**
 - *Note: the IP address (for the Gig0/1 interface, which connects the router to the LAN 2 switch) should be on the same network as the LAN 2 devices*

```
Router#conf t
Enter configuration commands, one per line.  End with CNTL/Z.
Router(config)#hostname RouterAC
RouterAC(config)#interface Gig0/1
RouterAC(config-if)#ip address 172.16.10.1 255.255.0.0
RouterAC(config-if)#no shutdown
```

Connecting 2 LANs



- **Setting up IP addresses for a second router (Gig0/0)**
- In *Global Configuration Mode (or Interface Mode for another interface)*:
 - type in and enter `interface Gig0/0` to enter *Interface Mode* for the Gig0/0 interface
 - type in and enter `ip address 201.5.5.2 255.255.255.252` to set an IP address for interface Gig0/0
 - type and enter `no shutdown` to change the interface's status to up

```
RouterAC(config-if)#interface Gig0/0
RouterAC(config-if)#ip address 201.5.5.2 255.255.255.252
RouterAC(config-if)#no shutdown
```

Connecting 2 LANs



- **Setting up IP addresses for a second router (Gig0/0)**
 - *Note: the IP address (for the Gig0/0 interface, which connects the Router AC to Router ICT) should be on the same network as Router ICT's Gig0/0 interface*
 - *i.e. the 201.5.5.0 /30 network which only has two hosts, the two routers*

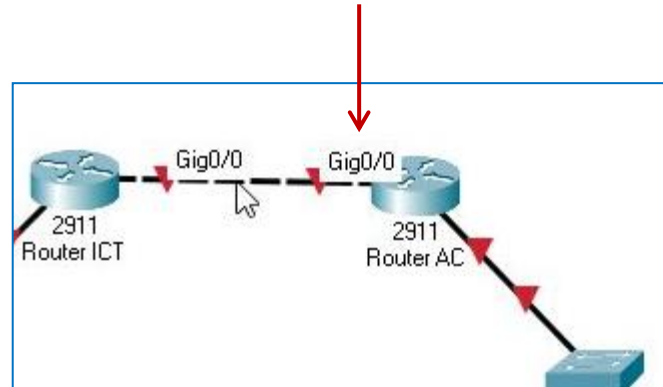



Connecting 2 LANs

- After setting up the interfaces for both routers, the crossover cable connection will be indicated as a successful connection (indicated in green)

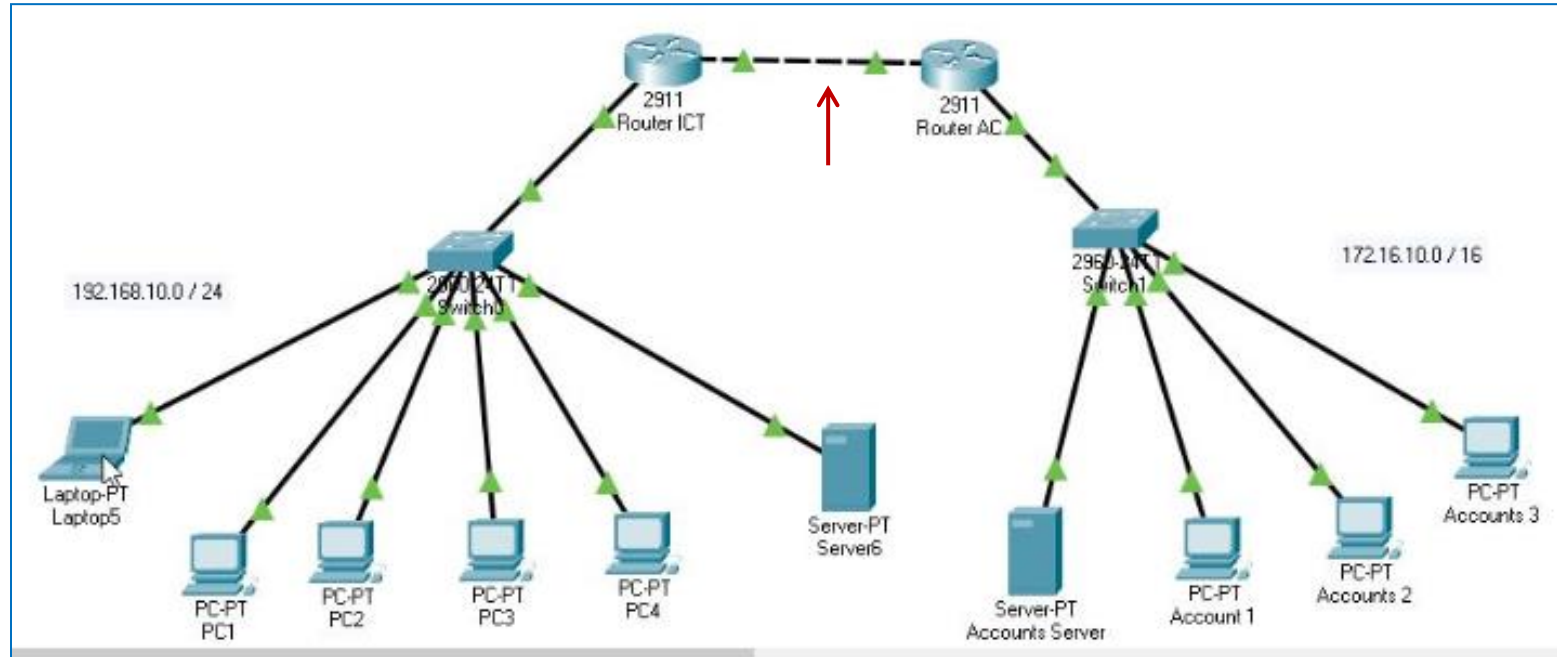



Connecting 2 LANs

- For successful connection between the devices across the two LANs:
 - Make sure the Default Gateway has been set to 192.168.10.1 (**Router ICT's Gig0/1 interface IP address**) for all the devices on LAN 1

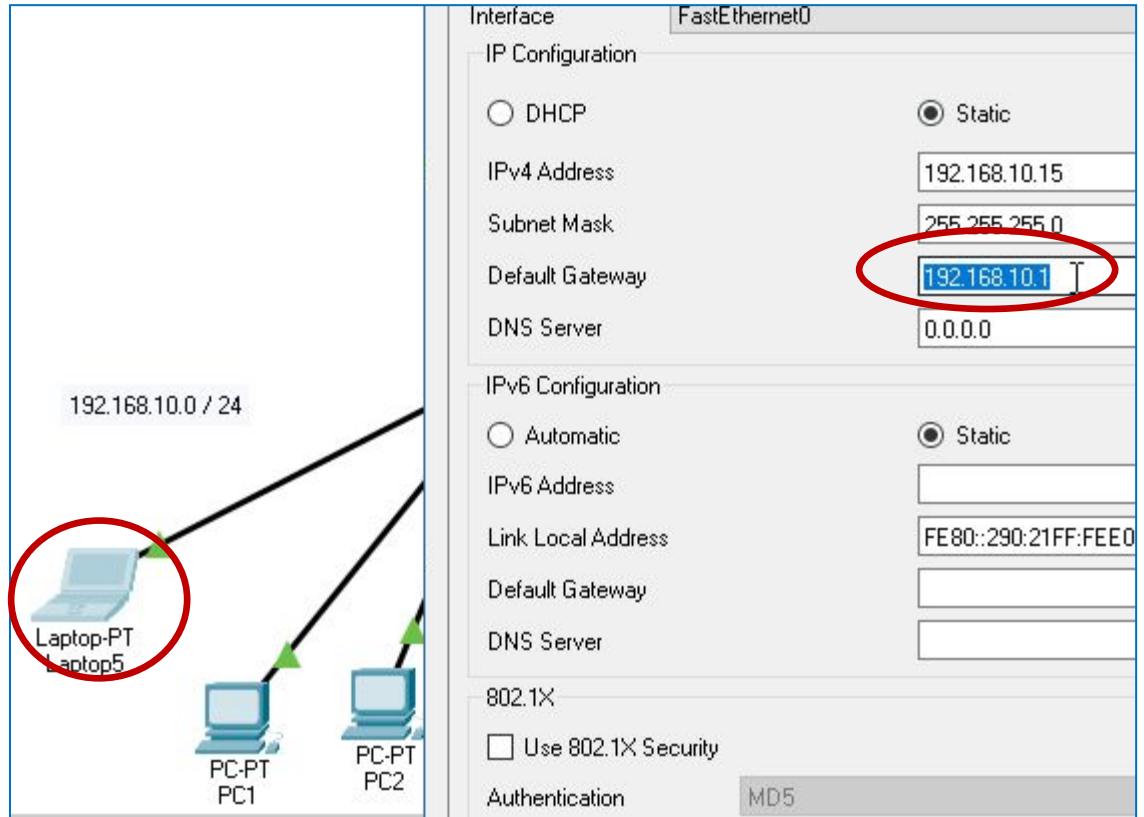

See Slides 64 for setting a Default Gateway for a PC / laptop



Connecting 2 LANs

- Similarly, for successful connection between the devices across the two LANs:
 - Make sure the Default Gateway has been set to 172.16.10.1 (**Router AC's Gig0/1 interface IP address**) for all the devices on LAN 2

The diagram shows a network topology where Router AC (2911) is connected to Switch1 (2960-24T1). Switch1 is connected to Server-PT Accounts Server. A red circle highlights the Server-PT Accounts Server in the diagram.

<input type="radio"/> DHCP	<input checked="" type="radio"/> Static
IPv4 Address	172.16.10.14
Subnet Mask	255.255.0.0
Default Gateway	172.16.10.1
DNS Server	0.0.0.0
IPv6 Configuration	
<input type="radio"/> Automatic	<input checked="" type="radio"/> Static
IPv6 Address	
Link Local Address	FE80::20A:F3FF:F
Default Gateway	
DNS Server	
802.1X	
<input type="checkbox"/> Use 802.1X Security	
Authentication	MD5
Username	
Password	



Connecting 2 LANs

- **Show IP route** command
 - shows the routing table of the router (i.e. all the networks the router can forward packets to)

syntax:

```
show ip route
```

- When in *Privileged Mode*
 - Type and enter `show ip route` to display routing table information

```
RouterAC>en
RouterAC#show ip route|
```



Connecting 2 LANs

- **Show IP route** command (cont.)

- For example: for our Router AC , the routing table will only show two networks which the router can forward packets to:
 - **172.16.0.0 /16** (LAN 2)
 - and **201.5.5.0 /30** (The routers network)
- As such a packet sent from LAN 2 with a destination in LAN 1 (192.168.10.0) the packet will be dropped at Router AC which has not included the LAN 1 network in its routing table (by default)

*In the routing table information:
C means **connected**
L means **local***

```
C      172.16.0.0/16 is directly connected,
GigabitEthernet0/1
L      172.16.10.1/32 is directly connected,
GigabitEthernet0/1
                201.5.5.0/24 is variably subnetted, 2 subnets
C      201.5.5.0/30 is directly connected, GigabitEthernet0/1
L      201.5.5.2/32 is directly connected, GigabitEthernet0/1

RouterAC#
```



Connecting 2 LANs

- **IP OSPF** command
 - allows the router to find (identify) other routers' networks which will be added to the router's routing table

syntax:

```
ip ospf process_id area area_number
```

- When in *Interface Mode* for a specific interface
 - Type and enter `ip ospf 1 area 1` to enable the OSPF protocol which will enable the router to search for the networks of other connected routers

```
RouterAC#en
RouterAC#conf t
Enter configuration commands, one per line
RouterAC(config)#interface Gig0/0
RouterAC(config-if)#ip ospf 1 area 1|
```



Connecting 2 LANs

- IP OSPF command (cont.)

syntax:

```
ip ospf process_id area area_number
```

- the **process_id** can be any integer (*we will use 1 for simplicity*)
 - An ID is assigned to the router's process maintaining the OSPF settings, this process ID can also be used when resetting the OSPF changes
- the **area_number** should be the same integer for both routers, i.e. when the interfaces are in the same **area**, each of the routers can add the other router's associated networks into their routing tables

```
RouterAC#en
RouterAC#conf t
Enter configuration commands, one per line.
RouterAC(config)#interface Gig0/0
RouterAC(config-if)#ip ospf 1 area 1
RouterAC(config-if)#
```



Connecting 2 LANs

- **IP OSPF** command (cont.)
 - **Open Shortest Path First (OSPF)**
 - A **routing protocol** which uses a Shortest Path First (SPF) algorithm to identify routers and networks within the same **area**

whereby the area can be set by the users setting up the routers

- **Protocol**
 - an **established set of rules** that determine how data is transmitted between different devices in the same network. Standardized rules which essentially allow different devices to communicate with each other



Connecting 2 LANs

- **IP OSPF** command
 - Note that the IP OSPF command has to be run for each interface of the router
 - When in *Interface Mode* for Router AC's **Gig0/0** and **Gig0/1** interfaces:
 - Type and enter `ip ospf 1 area 1` to enable the OSPF protocol for the interfaces
 - i.e. the command will be entered twice for Router AC

```
RouterAC (config-if) #interface Gig0/1  
RouterAC (config-if) #ip ospf 1 area 1
```

Connecting 2 LANs



- **IP OSPF** command
 - Add the use of the IP OSPF command should be done for the other router (Router ICT) as well
- When in *Interface Mode* for Router ICT's **Gig0/0** and **Gig0/1** interfaces:
- Type and enter `ip ospf 1 area 1` to enable the OSPF protocol for the two interfaces
- i.e. the command will be entered twice for Router ICT
 - and a total of 4 times for both routers

```
RouterICT>en
Password:
RouterICT#conf t
Enter configuration commands, one per line.
RouterICT(config)#interface Gig0/1
RouterICT(config-if)#ip ospf 1 area 1
RouterICT(config-if)#interface Gig0/0
RouterICT(config-if)#ip ospf 1 area 1
RouterICT(config-if)#exit
RouterICT(config)#exit
RouterICT#
```



Connecting 2 LANs

- After OSPF has been set
 - type and enter the `show ip route` command in *Privileged Mode* for RouterICT
 - A new connection should now be included in the routing table

```
RouterICT#show ip route|
```

```
O 172.16.0.0/16 [110/2] via 201.5.5.2, 00:00:33,  
GigabitEthernet0/0  
    192.168.10.0/24 is variably subnetted, 2 subnets  
C    192.168.10.0/24 is directly connected,  
GigabitEthernet0/1  
L    192.168.10.1/32 is directly connected,  
GigabitEthernet0/1  
    201.5.5.0/24 is variably subnetted, 2 subnets, 2  
C    201.5.5.0/30 is directly connected, GigabitEthernet0/0  
L    201.5.5.1/32 is directly connected, GigabitEthernet0/0  
RouterICT#
```

In the routing table information:

O means **OSPF**

C means **connected**

L means **local**

Connecting 2 LANs



- The 2 LANs are now connected successfully

- devices in LAN 1 can send and receive packets from LAN 2 through the two routers
 - After setting IP addresses on the routers' interfaces
 - turning the interfaces status to up via the `no shutdown` command
 - enabling OSPF settings for the routers to update their routing tables

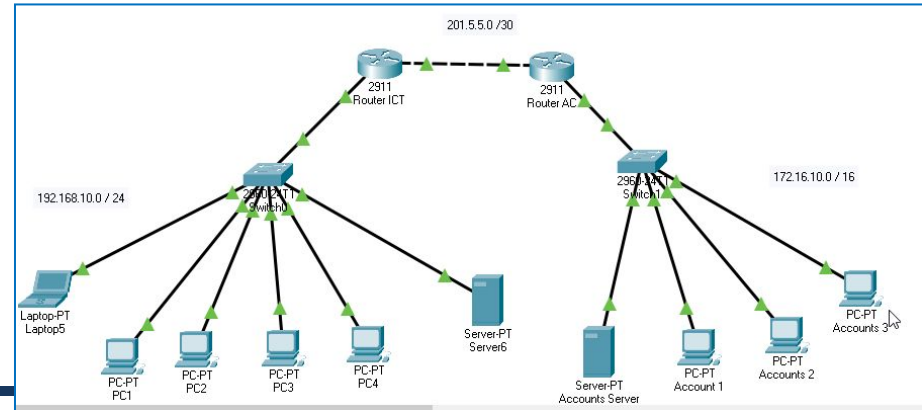



Connecting 2 LANs

- The 2 LANs are now connected successfully

Note: there are router commands for manually adding a network to a router's routing table, however, for our scope, we will utilize OSPF finding networks of other connected routers in the same area

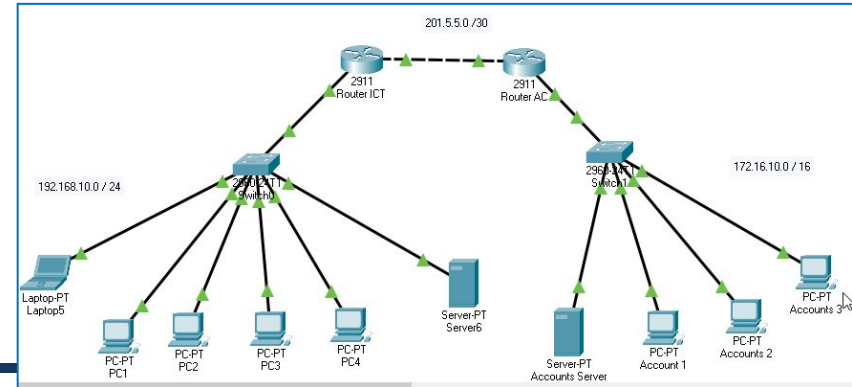

Connecting 2 LANs



- **Testing network connectivity:**
 - Use the **ping** command from a device in LAN 2
 - ping an IP address in LAN 1 (and vice versa)

A screenshot of a Packet Tracer PC Command Line window. The window title is "Accounts 2" and it has tabs for "Physical", "Config", "Desktop", "Programming", and "Attributes". The "Desktop" tab is active, showing a "Command Prompt" window. The text in the Command Prompt is as follows:

```
Packet Tracer PC Command Line 1.0
C:\>ping 192.168.10.15

Pinging 192.168.10.15 with 32 bytes of data:

Request timed out.
Reply from 192.168.10.15: bytes=32 time<1ms TTL=126
Reply from 192.168.10.15: bytes=32 time<1ms TTL=126
Reply from 192.168.10.15: bytes=32 time<1ms TTL=126

Ping statistics for 192.168.10.15:
    Packets: Sent = 4, Received = 3, Lost = 1 (25% loss),
    Approximate round trip times in milli-seconds:
        Minimum = 0ms, Maximum = 0ms, Average = 0ms

C:\>|
```

Connecting 2 LANs



- **Testing network connectivity:**
 - Alternatively, use the **Add Simple PDU** option
 - Click on the Add Simple PDU icon
 - click on a source in LAN 1 and then click on a source in LAN 2

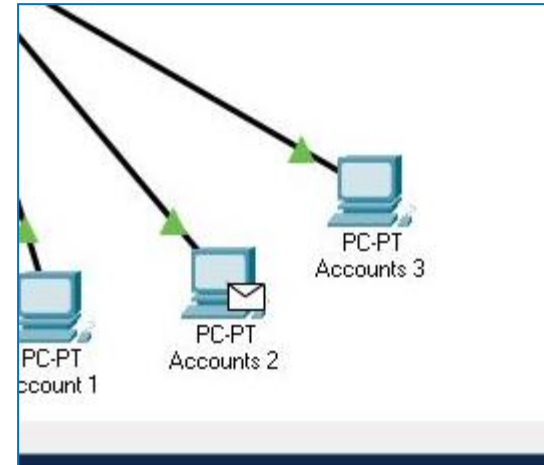
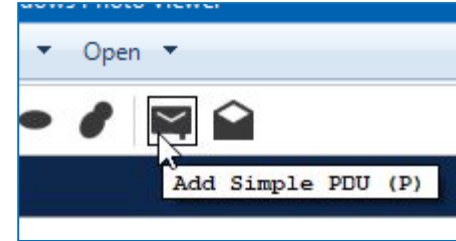



Connecting 2 LANs

- **Testing network connectivity:**
 - using the **Add Simple PDU** option
 - if the packet has been sent successfully, from LAN 1 to LAN 2, then the **Created Packet Window** (*bottom right*) will indicate a **Successful** last status

Fire	Last Status	Source	Destination	Type	Color
	--	PC3	PC1	ICMP	
	Successful	Account	Laptop5	ICMP	

Connecting 2 LANs – Clear IP OSPF Settings



- **No router OSPF** command
 - allows user to reset OSPF settings previously made on the router

syntax:

```
no router ospf process_id
```

- When in *Global Configuration Mode*
 - Type and enter `no router ospf 1` to reset the OSPF settings
 - The process id should match the process ID used in the previously used `ip ospf` command
 - This command (`no router ospf`) can be used when necessary, for example if the two routers have been set in two different areas (unintentionally) with the `ip ospf` commands



Reserved Private IP Addresses

- The Internet Engineering Task Force (IETF) organization has reserved **3 IP address ranges** to be used on private networks
 - **10.0.0.0** (for Class A)
 - **172.16.0.0** (for Class B)
 - **192.168.0.0** (for Class C)

As such, organizations may commonly use **192.168.0.0** Class C networks and **172.16.0.0** Class B networks, **however**, other Class A,B and C IP addresses can be used for private networks



Reserved Private IP Addresses

- The **3 IP address ranges** reserved and recommended for private networks:
 - **10.0.0.0 to 10.255.255.255** (16,777,216 IP addresses) (for Class A)
 - **172.16.0.0 to 172.31.255.255** (1,048,576 IP addresses) (for Class B)
 - **192.168.0.0 to 192.168.255.255** (65,536 IP addresses) (for Class C)



Reserved Private IP Addresses

- Routers using reserved private IP addresses **by default**:
- **Linksys** routers use 192.168.1.1
- **D-Link** routers are set to 192.168.0.1
- **Cisco** routers use either
 - 192.168.10.2
 - 192.168.1.254
 - or 192.168.1.1
- **SMC** routers often use 192.168.2.1

Note: these are simply default settings which can be changed in the routers settings where necessary

Router Modes

- User Mode
- Privileged Mode
- Global Configuration Mode

- Interface Mode
- Router Configuration Mode
- Line Mode
- Subinterface Mode

User EXEC Commands - Router>
ping enable
show (limited) etc...

Privileged EXEC Commands - Router#
all User EXEC commands
debug commands
reload
configure etc...

Global Configuration Commands - Router(config)#
hostname enable secret
ip route

interface ethernet
serial
bri
etc...

Interface Commands - Router(config-if)#
ip address encapsulation
ipx address shutdown / no shutdown
etc...

router rip
ospf
igrp
etc...

Routing Engine Commands - Router(config-router)#
network auto-summary
version etc.

line vty
console
etc...

Line Commands - Router(config-line)#
password modem commands
login etc...



More Common Router CLI Commands

- The following link includes more common router commands (*beyond the commands we have covered above*):
- https://www.netwrix.com/cisco_commands_cheat_sheet.html

*Exercise: from a Packet Tracer router's CLI: use (and know the use of) the **ping**, **speed**, **duplex** and **show interfaces** commands