

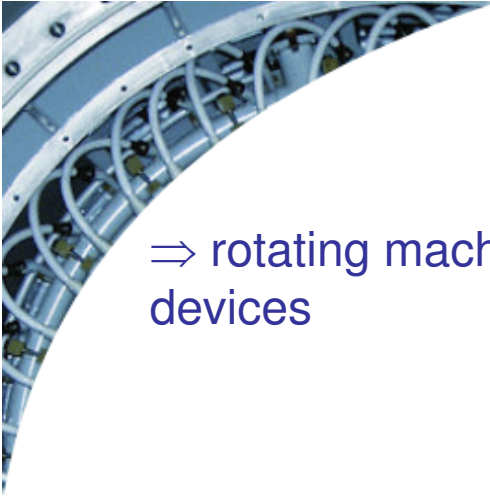

Rotating Machines

- introduction
- induced voltage
 - typical electrical machine
 - average value
 - frequency
- connection to output
 - slip ring
 - commutator
- torque



Introduction

⇒ rotating machines include motors and generators: they are both power conversion devices

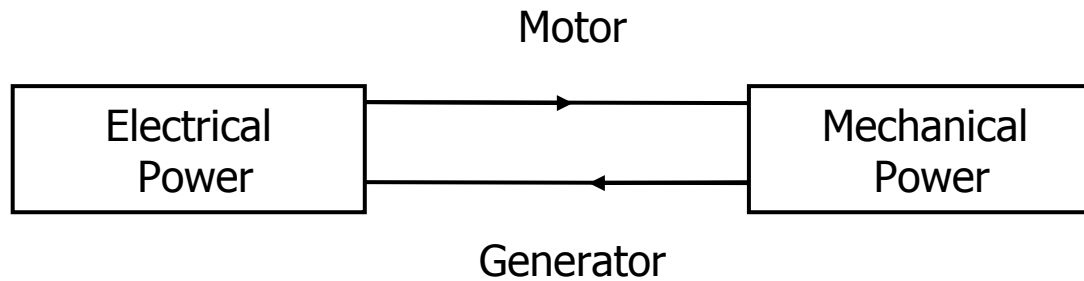

⇒ Faraday's law for one turn of coil:

$$v = \frac{d\phi}{dt} = \frac{\partial\phi}{\partial t} + \frac{\partial\phi}{\partial x} \cdot \frac{\partial x}{\partial t} = \frac{\partial\phi}{\partial t} + u \frac{\partial\phi}{\partial x}$$

$\frac{\partial\phi}{\partial t}$: changing flux with time, as in transformer, i.e. Flux-linking

$u \frac{\partial\phi}{\partial x}$: with motion at speed u , as in rotating machines, i.e. Flux-cutting

Induced voltage

- consider a conductor of length l
- carrying a current i ,
- moving at speed u ,
- in a steady field of flux density B
- (B , l , u are mutually perpendicular)

in a time δt , the motion

$$\delta x = u \delta t$$

flux cut is

$$\delta \phi = Bl \delta x$$

induced voltage is

$$v_{in} = u \frac{\delta \phi}{\delta x} = Blu$$

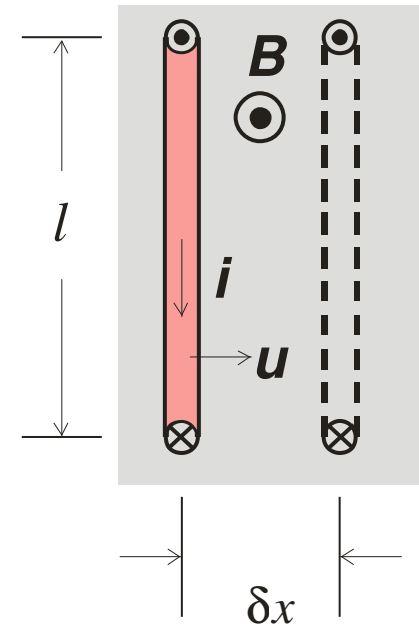

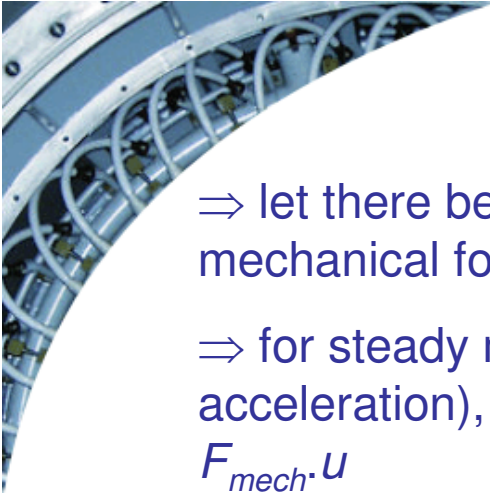

⇒ let there be an associated mechanical force, F_{mech} .

⇒ for steady motion (no acceleration), Mechanical power is $F_{mech} \cdot u$

⇒ electrical power is

$$vi = Blui$$

⇒ applying law of conservation of energy in unit time, ignoring losses

$$F_{mech}u = Blui$$

$$F_{mech} = Bli$$

Typical electrical machine

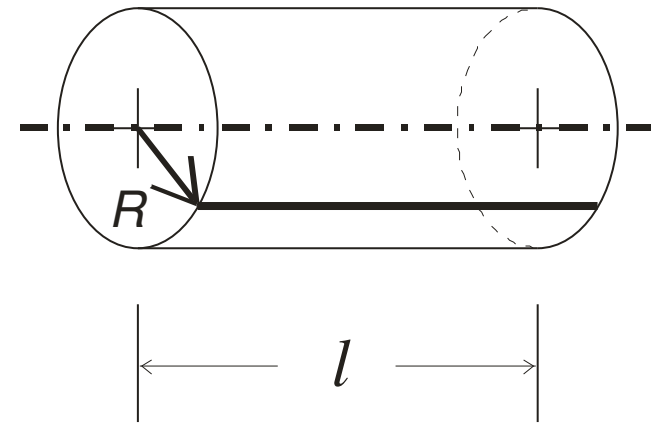
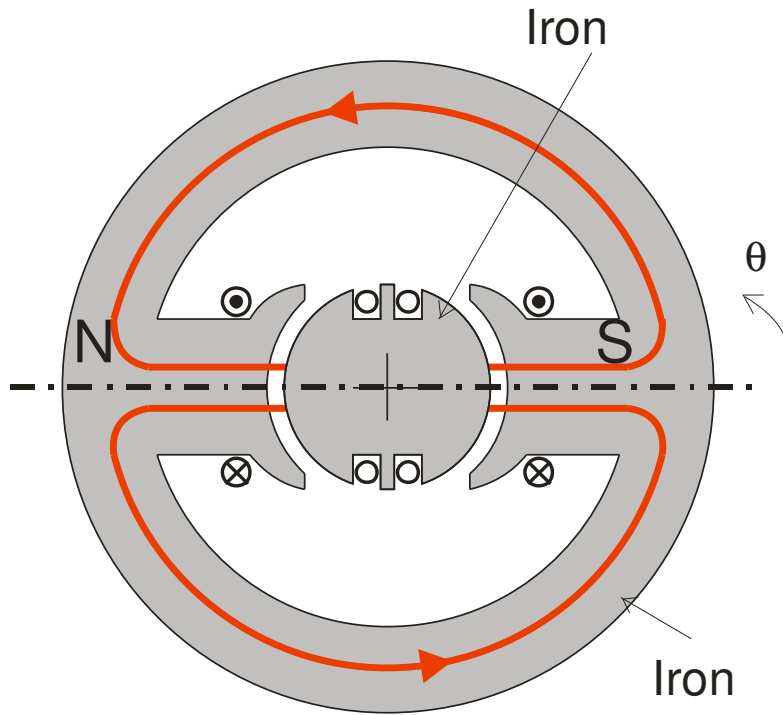

⇒ for a conductor of length l , moving at speed u , in rotor,

$$v_{in} = Blu$$

⇒ rotational speed is n [rev/s}

$$u = 2\pi Rn$$

$$v_{in} = (2\pi Rnl)B$$

$$v_{in} \propto B$$

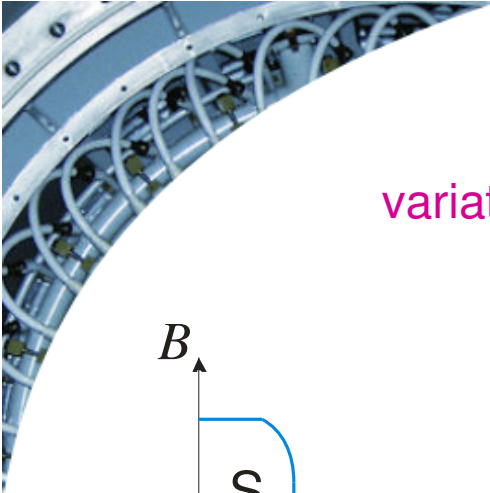

variation of B for 1 rev.

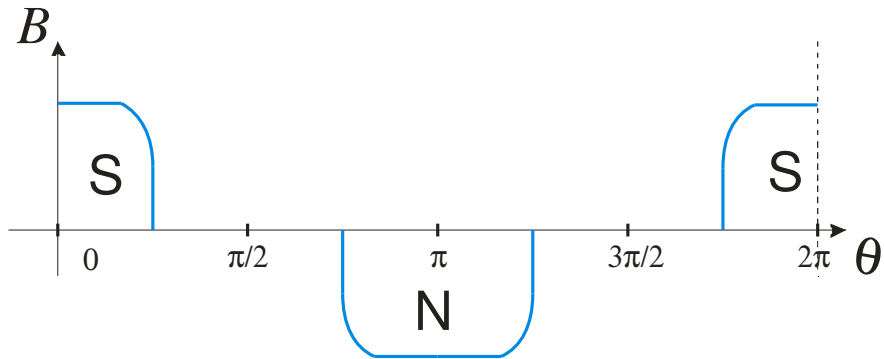

variation v_{in} for rev

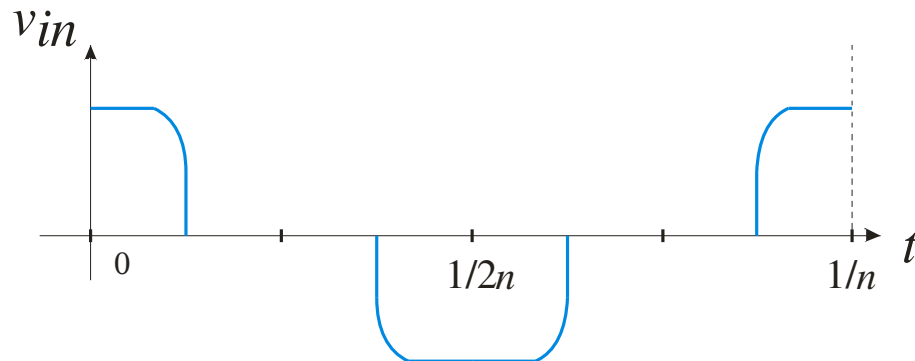

a more realistic B - θ distribution

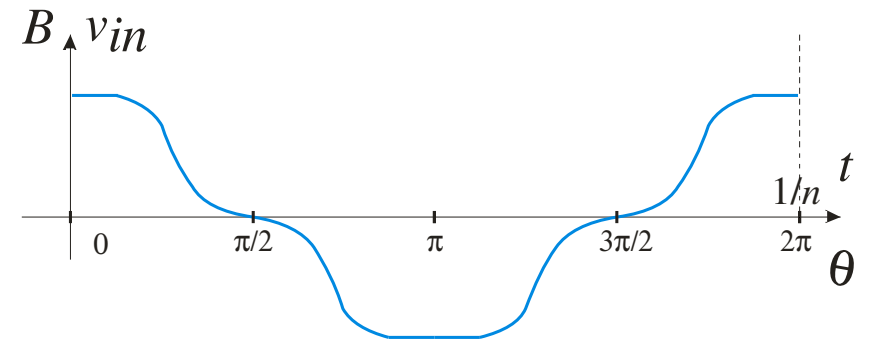

\Rightarrow the detailed graph of B against θ can be used with suitable change of scales for v_{in} against time

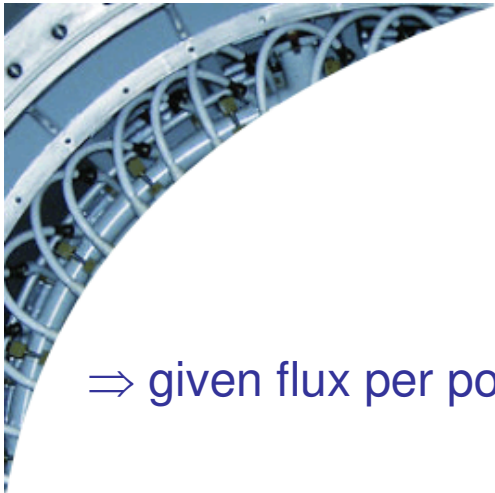

average value of induced voltage

⇒ given flux per pole, ϕ

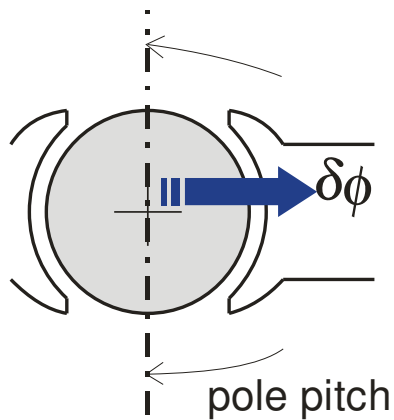

$$\int \delta\phi = \phi$$

$$v_{in|_{av}} = \frac{\int_0^{\frac{T}{2}} Bludt}{\frac{T}{2}} = \frac{\int_0^{\frac{1}{2n}} Bludt}{\frac{1}{2n}} = \frac{\int d\phi}{\frac{1}{2n}} = 2n\phi$$

⇒ for a m/c with p pole pairs

⇒ time for 1 rev is $1/n$

⇒ time for 1 pole pitch is

$$= \frac{1}{2p} \frac{1}{n}$$

⇒ if flux per pole is ϕ

$$V_{in|_{av}} = \frac{\phi}{1/2np}$$

$$V_{in|_{av}} = 2np\phi$$

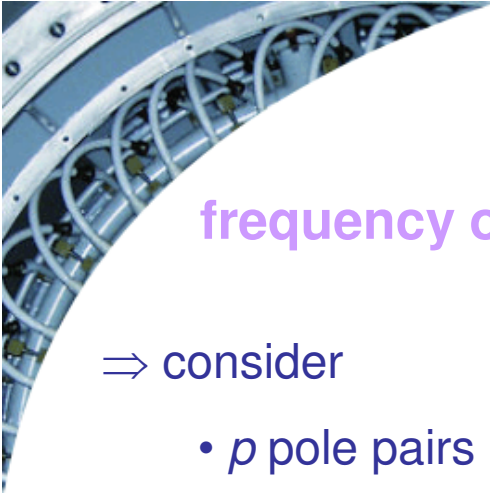

frequency of induced voltage

⇒ consider

- p pole pairs
- speed of rotation n

⇒ 1 pole gives half cycle

⇒ 1 pole pair gives 1 cycle

⇒ p pole pairs give p cycles

- this is 1 rev, happening in time $1/n$ [s]

⇒ ∴ p cycles occur in $1/n$ [s]

⇒ this is the frequency measured in c/s or Hertz [Hz]

$$f = np$$

summary

$$V_{av} = 2np\phi$$

$$f = np$$

Connection to output

Case 1: ac output (slip rings)

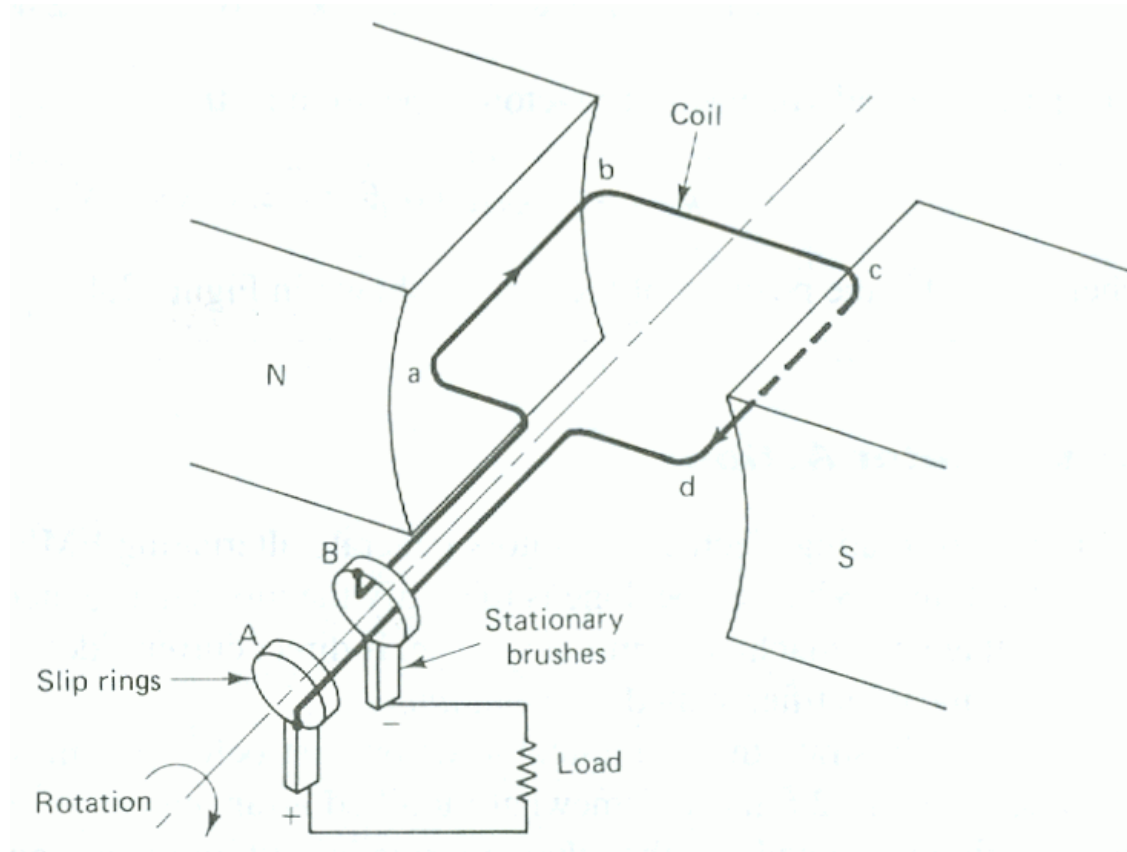

⇒ brass rings fixed to shaft
⇒ carbon brushes pick up

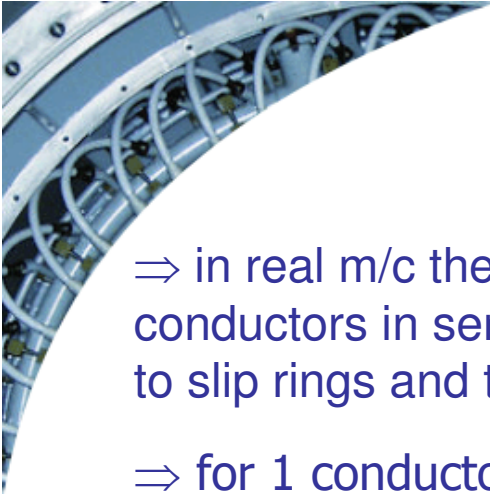

⇒ in real m/c there will be many conductors in series Z_s for connection to slip rings and the output

⇒ for 1 conductor

$$V_{av} = 2pn\phi$$

⇒ for Z_s conductors connected in the same slot

$$V_{av} = 2pn\phi Z_s$$

⇒ for Z_s conductors spread around the rotor periphery:

- the voltage vs time for each conductor will have the same shape and magnitude
- if the slots are spread every 10° for example, the voltage waveforms for the conductors in adjacent slots will be shifted every 10°
- the waveform of the total voltage will be bigger and also smoother than that for a single conductor
- taking into account the form factor for sine waves and winding factor for cylindrical rotor, we have output rms voltage as

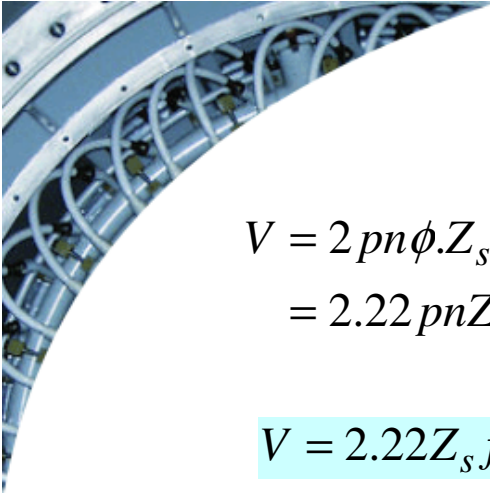

$$V = 2pn\phi.Z_s.k.(1.11)$$

$$= 2.22pnZ_s\phi k$$

$$V = 2.22Z_s f \phi k$$

⇒ k is winding factor, which includes distribution factor k_d

⇒ this particular m/c with slip rings gives out an ac waveform which is designed to be sinusoidal

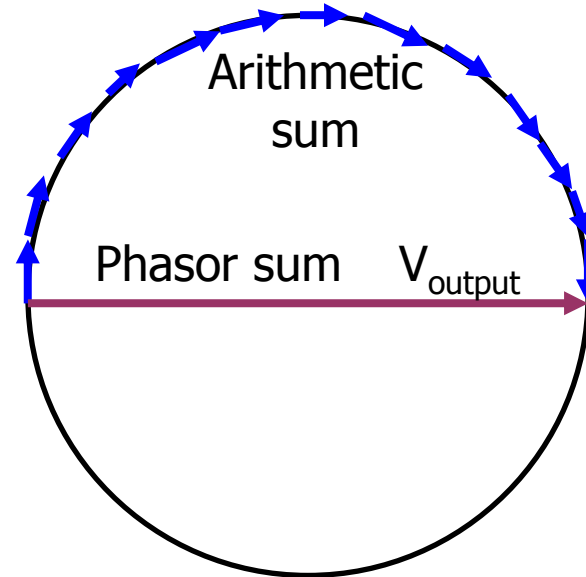

$$k_d = \frac{\text{Phasor sum}}{\text{Arithmetic sum}} = \frac{\text{chord}}{\text{arc}}$$

Case 2: dc output (commutator)

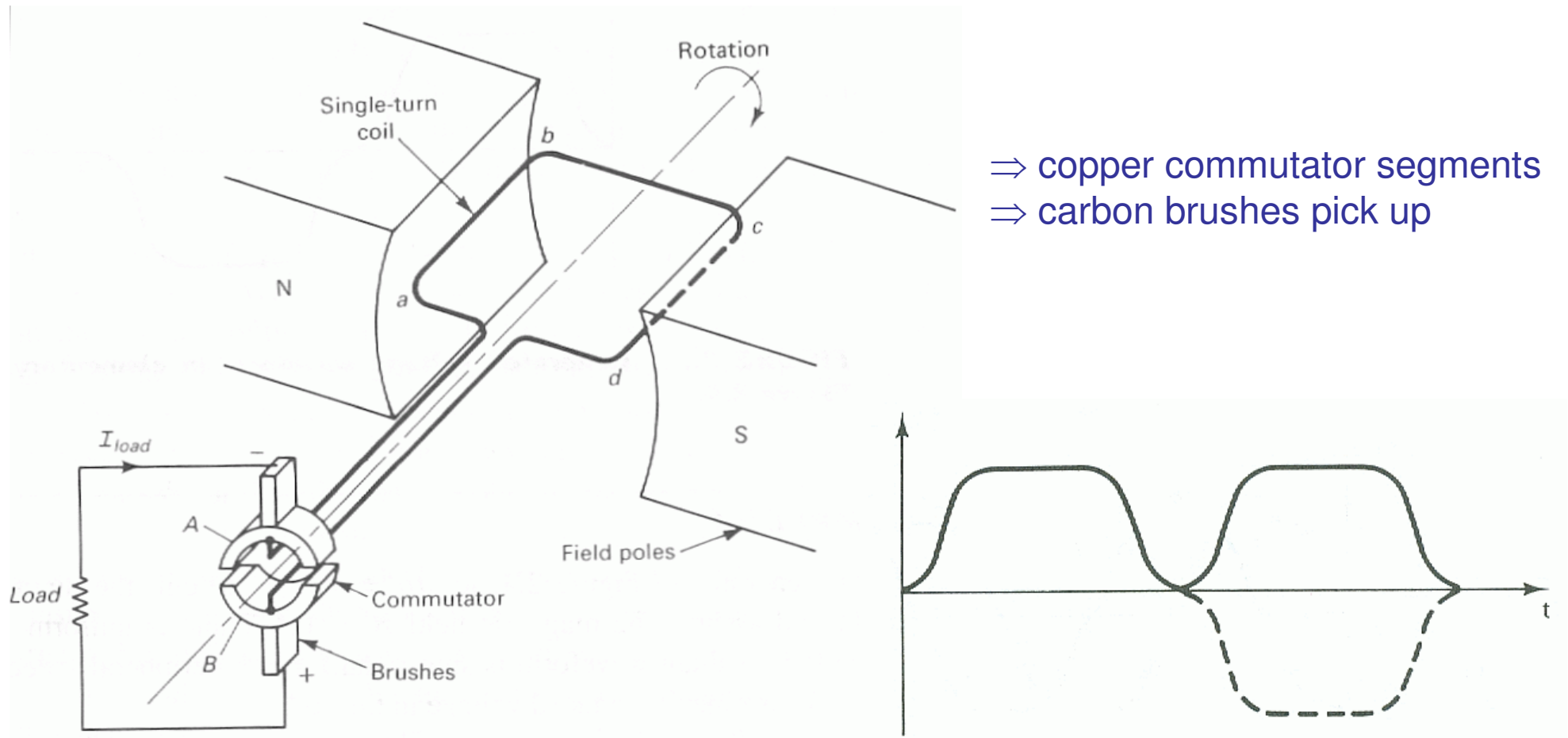

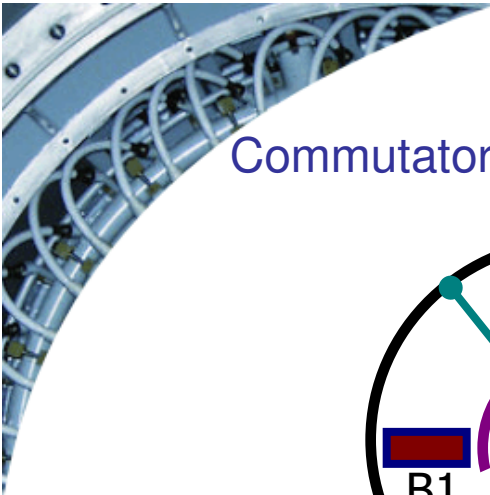

Commutator connections:

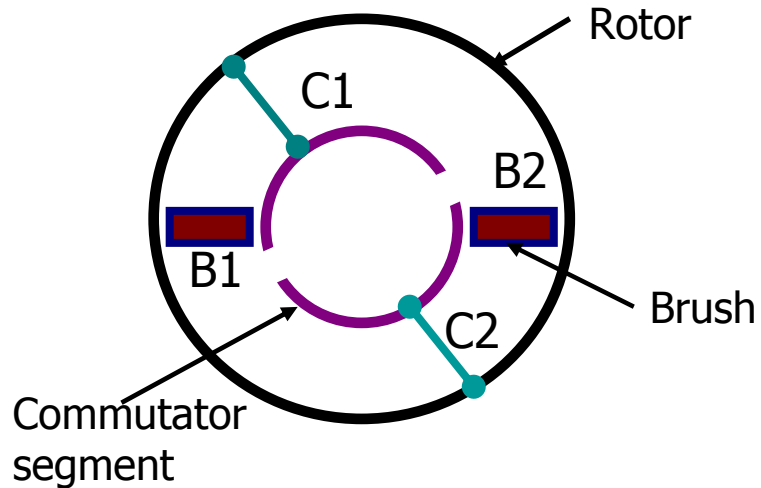

1 st half Period	2 nd half Period
B1 – C1	B1 – C2
B2 – C2	B2 – C1

B = brush terminal

C = commutator segment

⇒ connections thru' a commutator will give an output voltage which is unidirectional

$$V_{av} = 2pn\phi$$

⇒ if the rotor has a total of Z conductors; and if there are c paths in parallel, e.g.

$Z = 20, c = 4$:

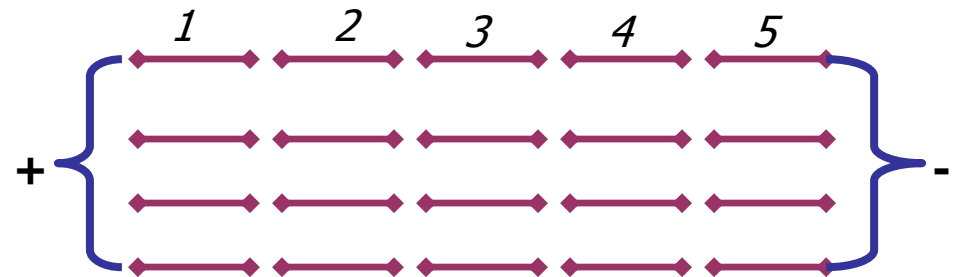

$$Z_s = \frac{20}{4}$$

⇒ In general

$$Z_s = \frac{Z}{c}$$

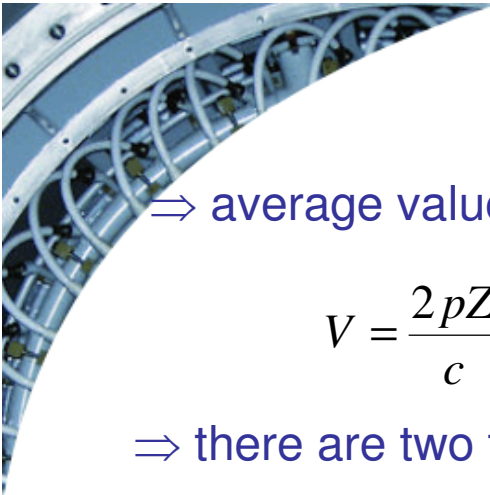

⇒ average value of total d.c. voltage output

$$V = \frac{2pZ}{c} n\phi$$

⇒ there are two types of windings:

LAP winding, for which $c = 2p$

WAVE winding, for which $c = 2$

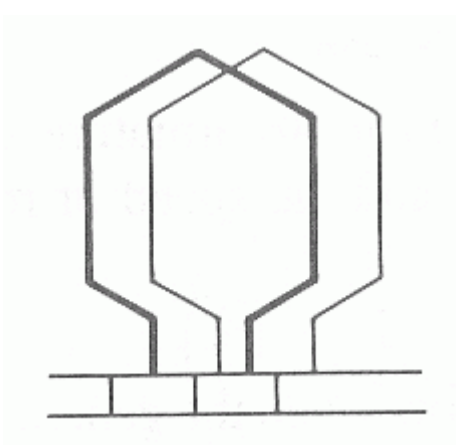

Lap interconnection

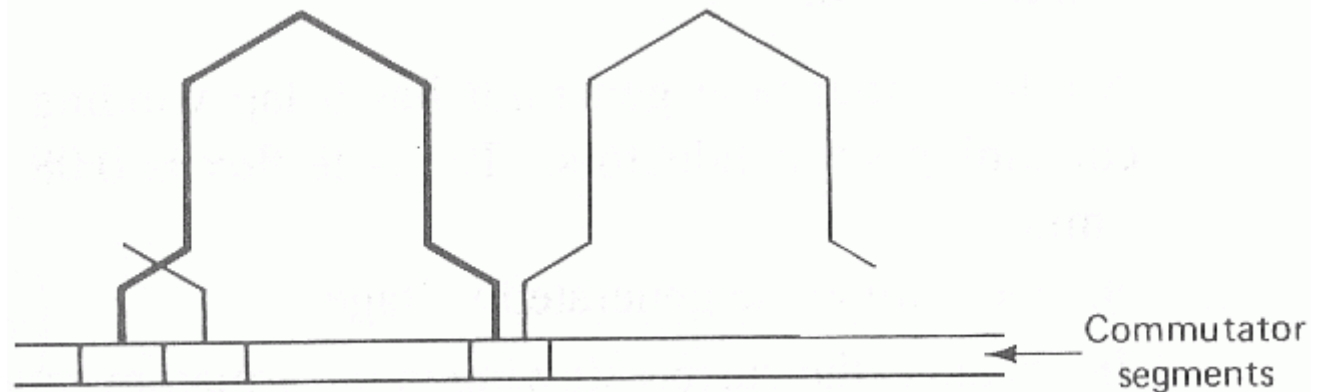

wave interconnection



Torque

⇒ applying the “law of conservation of energy” and neglecting losses:

Mechanical power input = Electrical power output

$$2\pi nT = VI$$

$$T = \frac{1}{2\pi n} \left(\frac{2pZ}{c} n\phi \right) I$$

$$T = \frac{1}{2\pi} \left(\frac{2pZ}{c} \right) I\phi$$

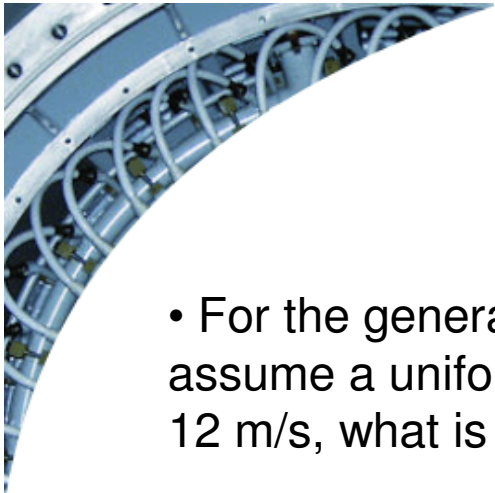

Examples

- For the generator shown in the caption (slip ring output), $ab = cd = 20$ cm and assume a uniform magnetic field $B = 0.5$ T. For a peripheral speed of the coil sides of 12 m/s, what is the maximum voltage appearing at the slip rings?
- A 60-kW 4-pole generator has a lap winding placed in 48 armature slots, each slot containing 6 conductors. The pole flux is 0.08 Wb and the speed of rotation is 1040 r/min
 - what is the generated voltage?
 - what is the current flowing in the armature conductors when the generator delivers full load?
- The armature of a dc motor has 320 conductors, only 70% of which lie directly under poles, where the flux density is 1.1 T. The armature diameter is 26 cm and its length is 18 cm. The conductor current is 12 A. Find
 - the total force created by the conductors
 - the shaft torque developed