

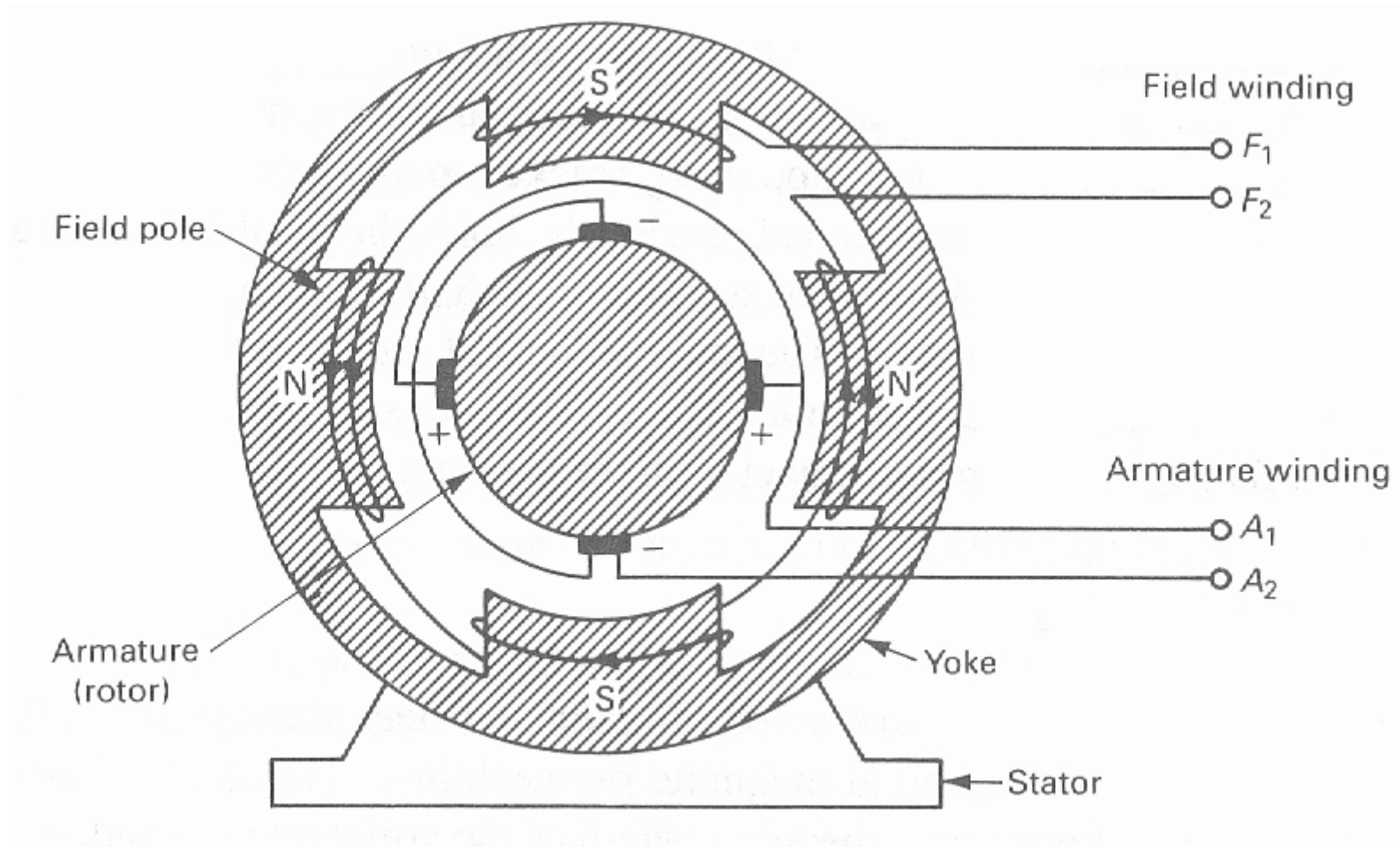

DC Machines

- Introduction
- Equivalent circuit
- Production of flux
- Power flow diagrams
- DC machine configurations
- DC generator
 - separate excitation
 - shunt excitation
- DC motor
 - separate excitation
 - shunt excitation
 - series excitation
- Starting of DC motors

Introduction



4-pole dc machine



Introduction

⇒ dc machines consist of 2 or more sources of magnetic excitation coupled magnetically by means of a magnetic system

⇒ there are 2 principal excitations (hence doubly excited machine), i.e.

- field
- armature

Field System

⇒ function is to supply energy to establish a magnetic field in the magnetic circuit

⇒ use of electrical **field winding** gives great DIVERSITY and VARIETY of performance characteristics that typify dc machines

⇒ **permanent magnet** excitation may be employed

⊂ is often less costly & occupies less space

⊂ eliminates need for separate source of energy

⊂ limited power for large machines (limited to few 100 W, until recently)

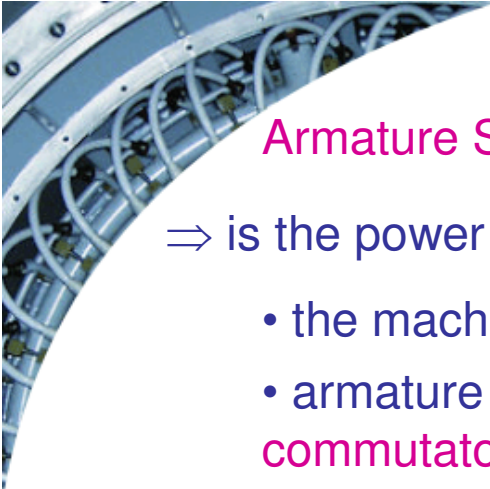

Armature System

⇒ is the power winding of a dc machine

- the machine's electromagnetic torque is a function of armature current
- armature terminals are connected to the external power source/use through **commutator / brush** system

⇒ commutator / brush system acts a mechanical switching device between the external circuit and the armature winding within the machine

⇒ external connection of the armature winding are made through the brushes resting on the commutator

- brushes are held in stationary fixed positions
- commutator rotates with the rotor
- brushes are one pole-pitch apart

⇒ In **lap** winding:

- a number of brush positions equal to number of poles is required
- half the positions are +ve, half are -ve; positive and negative groups are paralleled through external electrical connections

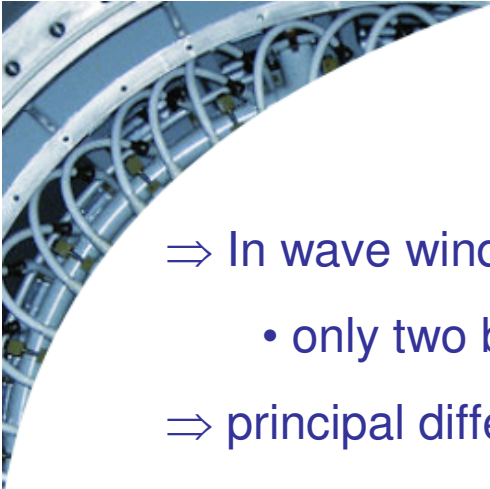

⇒ In wave winding

- only two brush position are required: one +ve and one –ve

⇒ principal difference between lap and wave concerning electrical performance:

- the number of parallel electrical paths through the winding between +ve and –ve terminals of the armature

⇒ designate c for number of parallel paths between armature winding terminals

- lap: $c = 2p$

- wave: $c = 2$

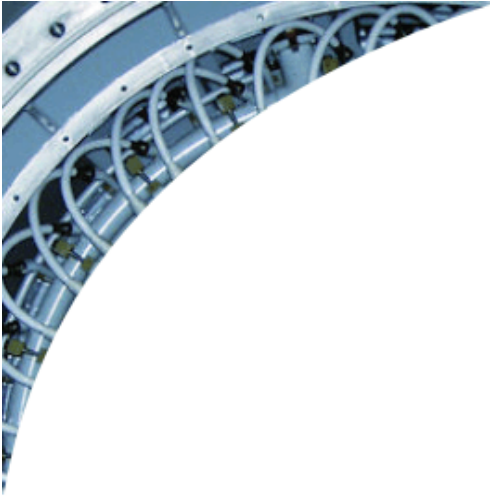

Equivalent circuit of DC machine

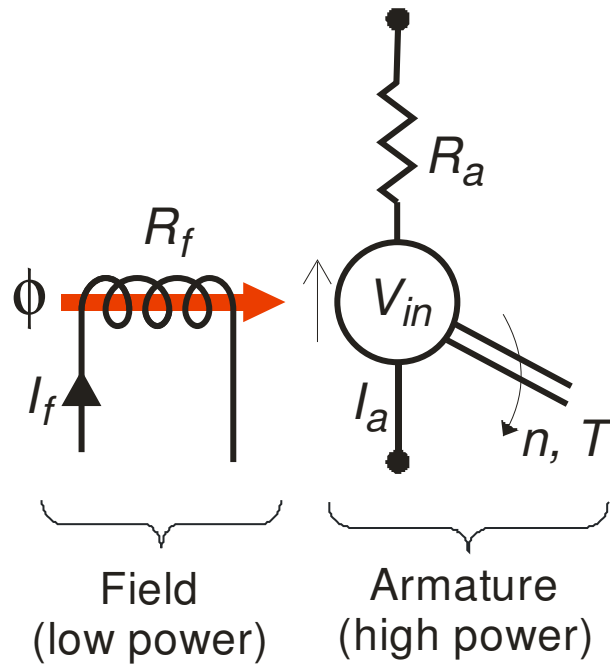

Losses

1. Copper Loss:

- armature $\rightarrow I_a^2 R_a$
- field $\rightarrow I_f^2 R_f = V_f I_f = \frac{V_f^2}{R_f}$

2. Mechanical loss

- iron loss
- friction
- windage

Production of flux

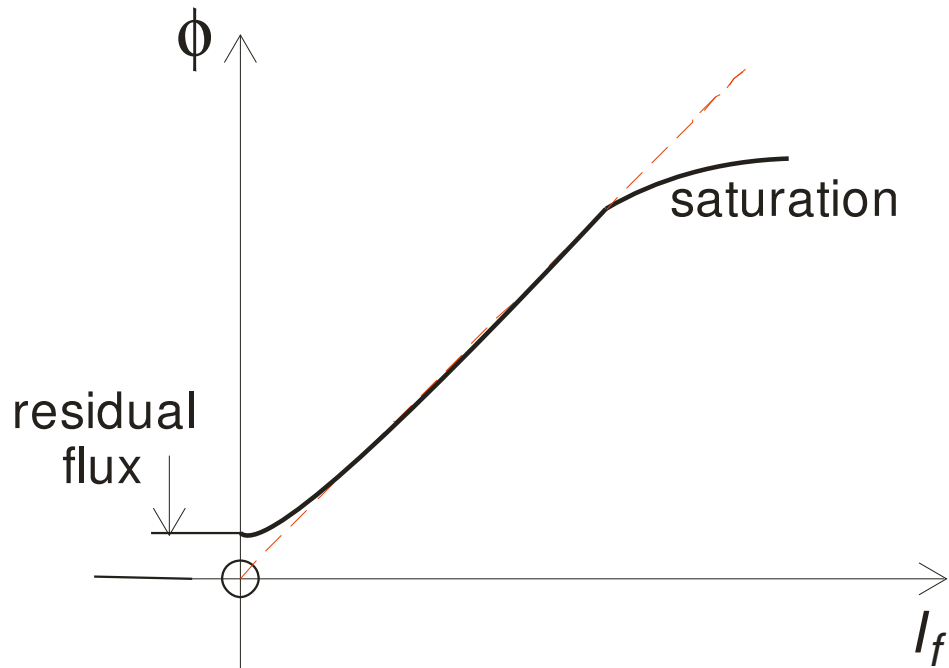

$$\phi = \frac{F}{S} = \frac{N_f I_f}{S}$$

- it is a linear relationship between ϕ and I_f if S is assumed constant
- deviation occurs because saturation appears when ϕ increases

Power flow diagrams

Generator

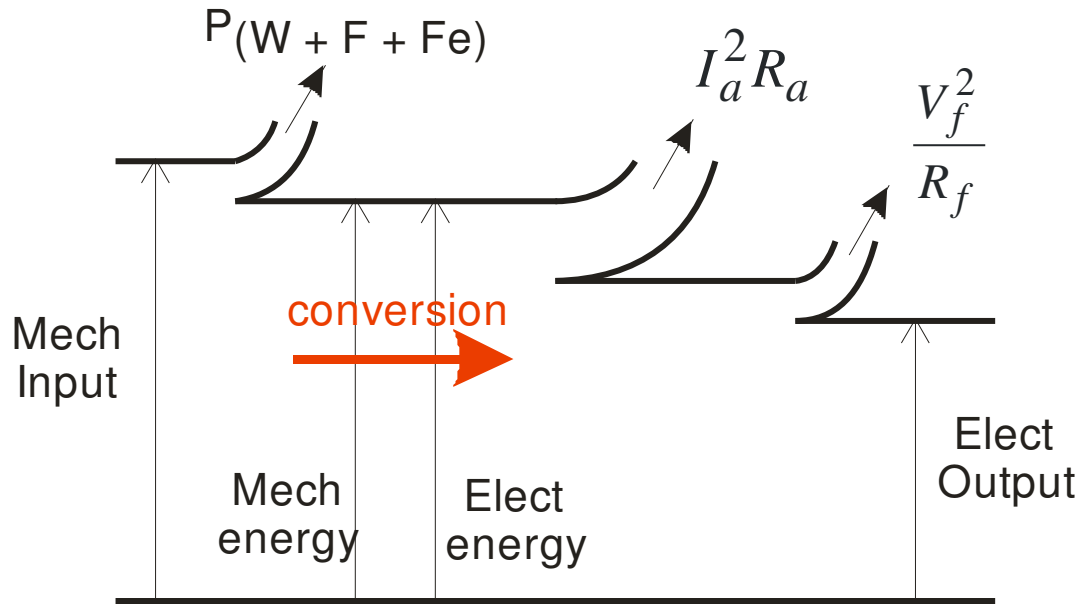

$$\eta = \frac{\text{elec. output}}{\text{mech. input}}$$

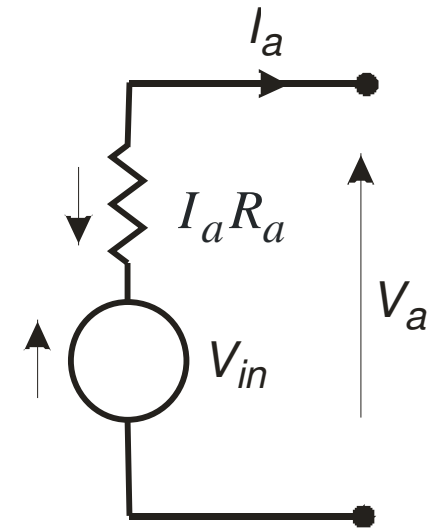

$$V_{in} = \left(\frac{2pZ}{c} \right) n \phi$$

$$V_a = V_{in} - I_a R_a$$

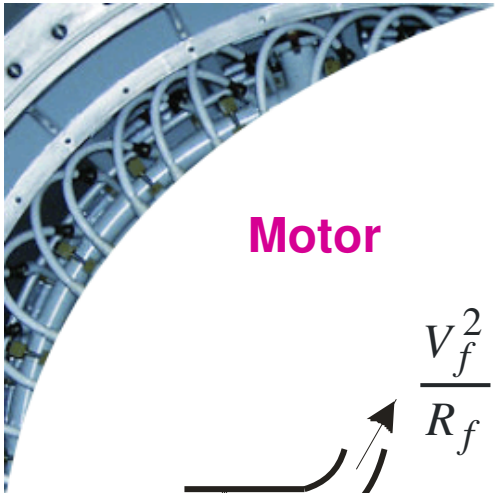

Motor

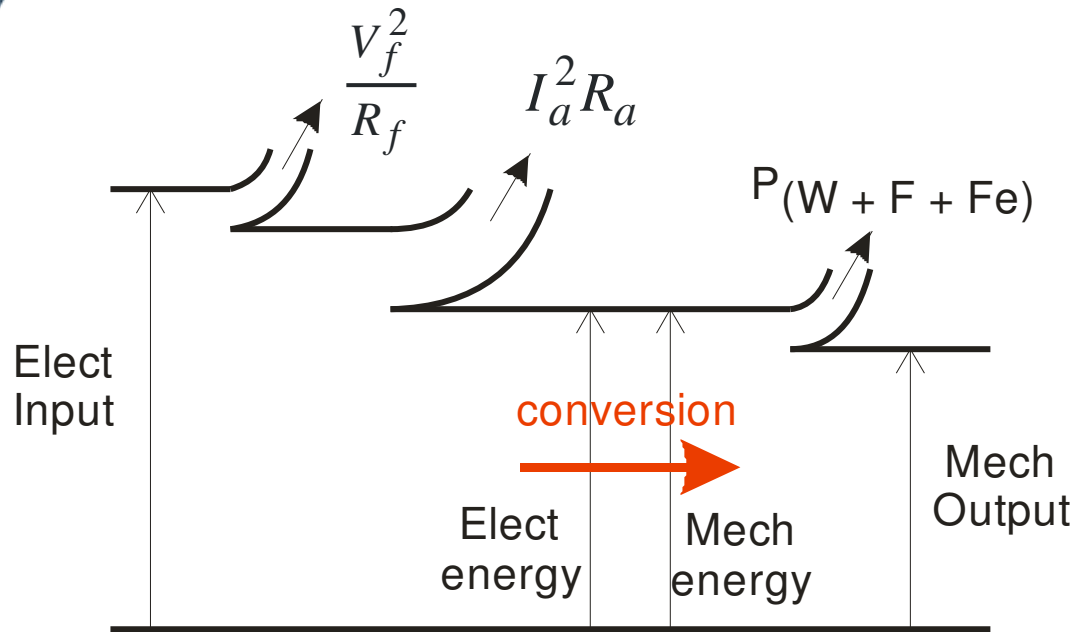

$$\eta = \frac{\text{elec. output}}{\text{mech. input}}$$

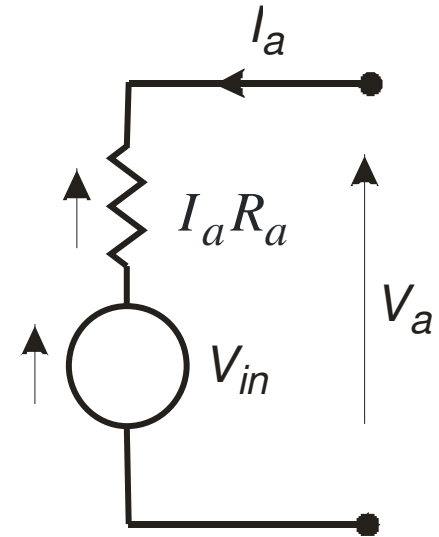

$$V_{in} = \left(\frac{2pZ}{c} \right) n\phi$$

$$V_a = V_{in} + I_a R_a$$



DC machine configurations

⇒ field winding connection determines the type of dc machine arrangement

⇒ field winding can either be connected in

- separate
 - series
 - shunt
 - compound
- a winding in dc machine is designated as:

winding	BS4999 pt3 (1977)	BS8222 pt 6 (1964)
armature	A1 – A2	A – AA
separate	F1 – F2	X – XX
series	D1 – D2	Y – YY
shunt	E1 – E2	Z – ZZ

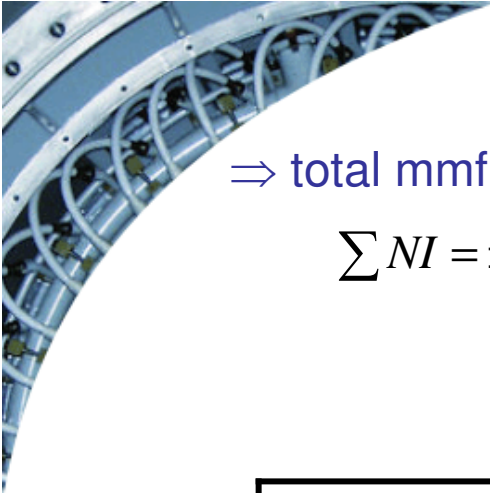

⇒ total mmf on d -axis is

$$\sum NI = \pm N_X I_X \pm N_Y I_Y \pm N_Z I_Z$$

Field	$\sum NI$	
separate	$\pm N_X I_x + 0 + 0$	
series	$0 \pm N_Y I_Y + 0$	
shunt	$0 + 0 \pm N_Z I_Z$	
Compound (cumulative)	$0 + N_X I_x + N_Z I_Z$	$0 - N_X I_x - N_Z I_Z$
Compound (differential)	$0 + N_X I_x - N_Z I_Z$	$0 - N_X I_x + N_Z I_Z$

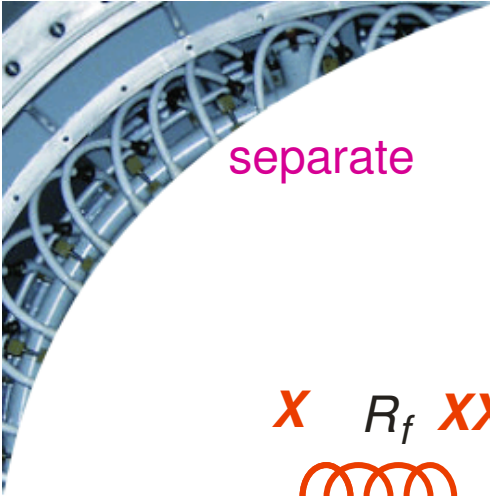

separate

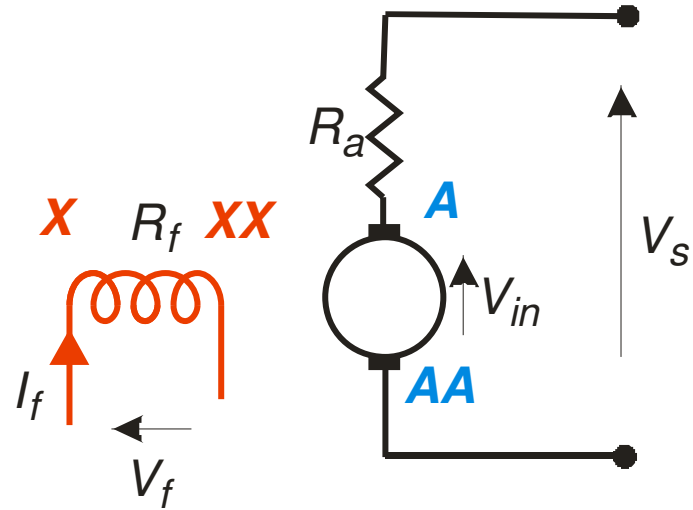

shunt

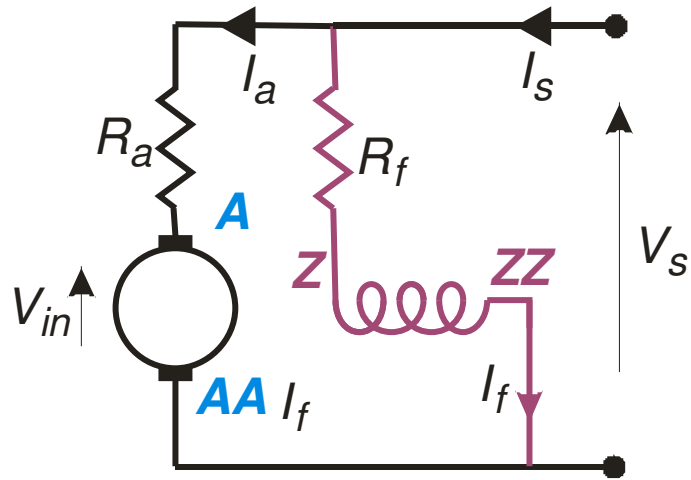

series

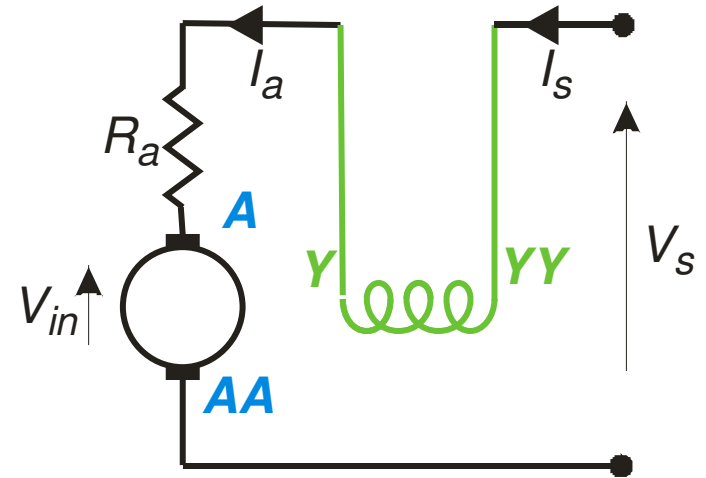

compound

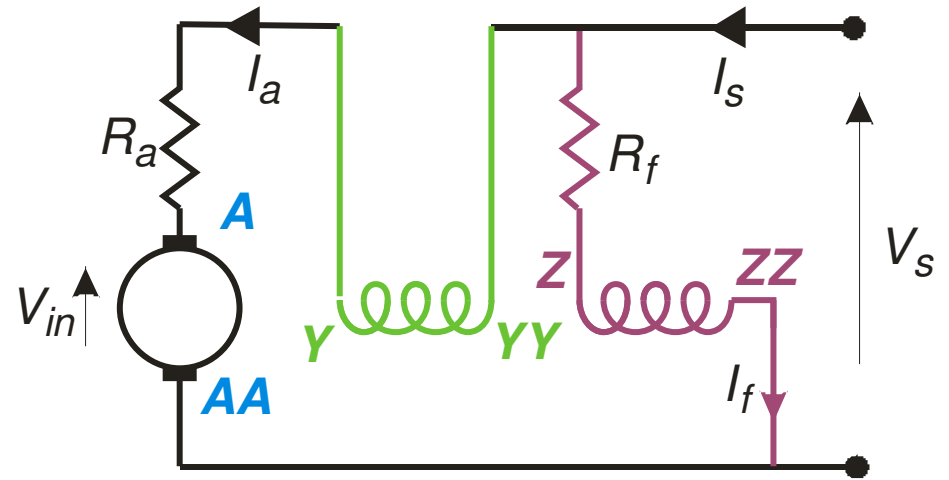



DC Generator

⇒ dc supplies are commonly derived from ac supplies by rectification

⇒ dc generators are built with outputs of a few W to several MW for applications in

- electrochemical plants for electro deposition and metal refining
- battery charging for standby or emergency supply
- diesel-electric locomotives
- synchronous machine excitation
- automatic control systems
- etc

Saturation curve

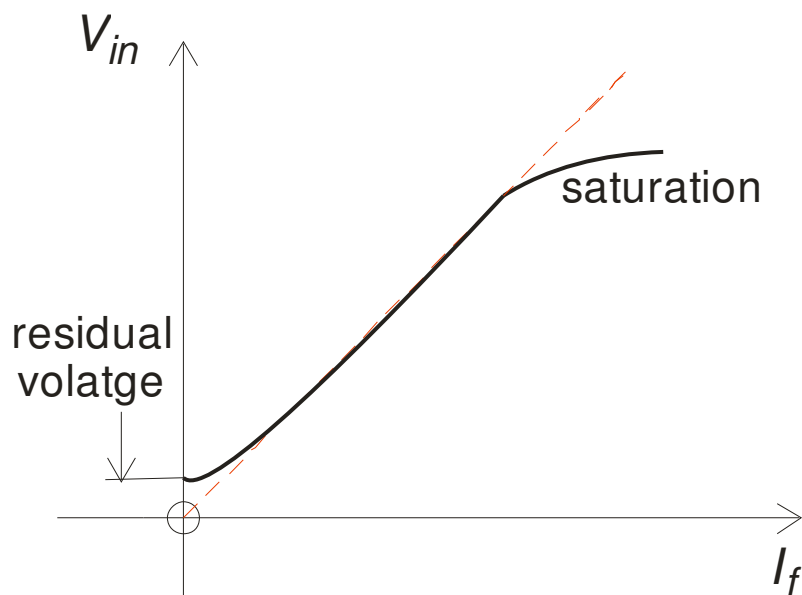
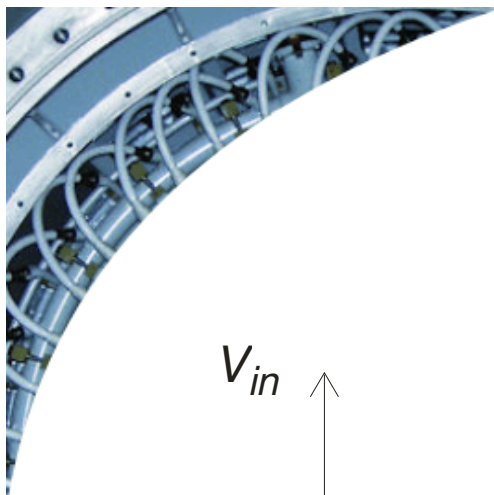

⇒ the no-load saturation curve a dc machine is a curve of induced armature emf V_{in} versus field current I_f for the machine running at rated speed on no-load

⇒ a.k.a. **open-circuit characteristic** or **magnetisation curve**

$$V_{in} = \left(\frac{2pZ}{c} \right) n \phi$$

$$V_{in} \propto \phi \quad (n \text{ const.})$$

$$V_{in} \propto n \quad (I_f \text{ const.})$$

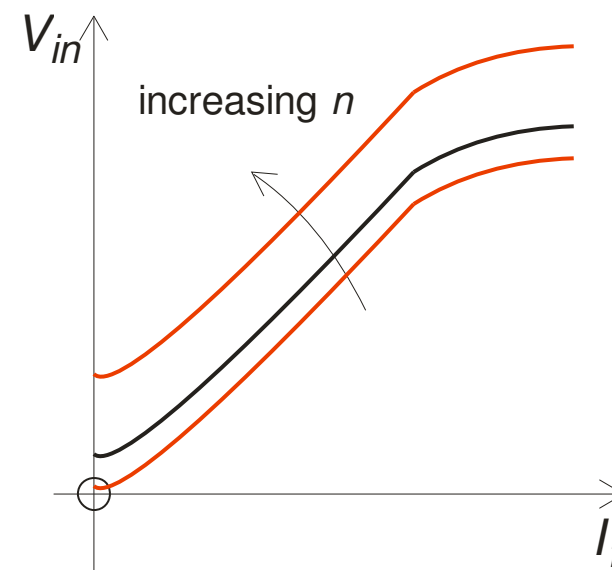

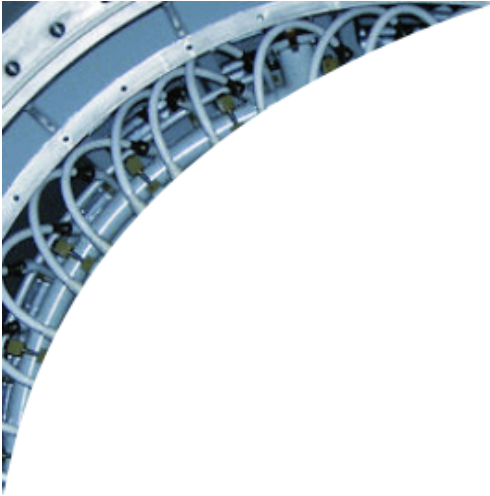

DC generator equivalent circuit

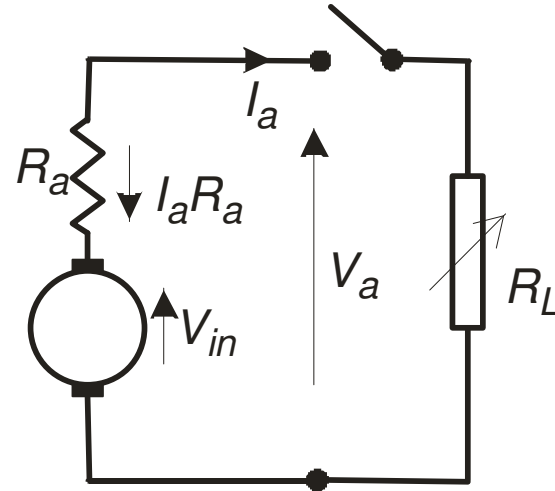
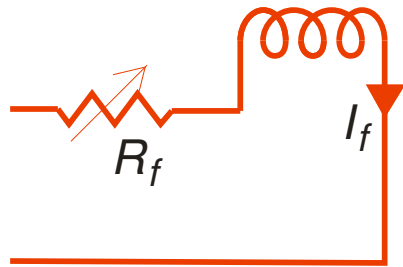

$$V_{in} = \left(\frac{2pZ}{c} \right) n\phi$$

$$V_a = V_{in} - I_a R_a$$

Separate excitation

⇒ I_f from a separate source (external)

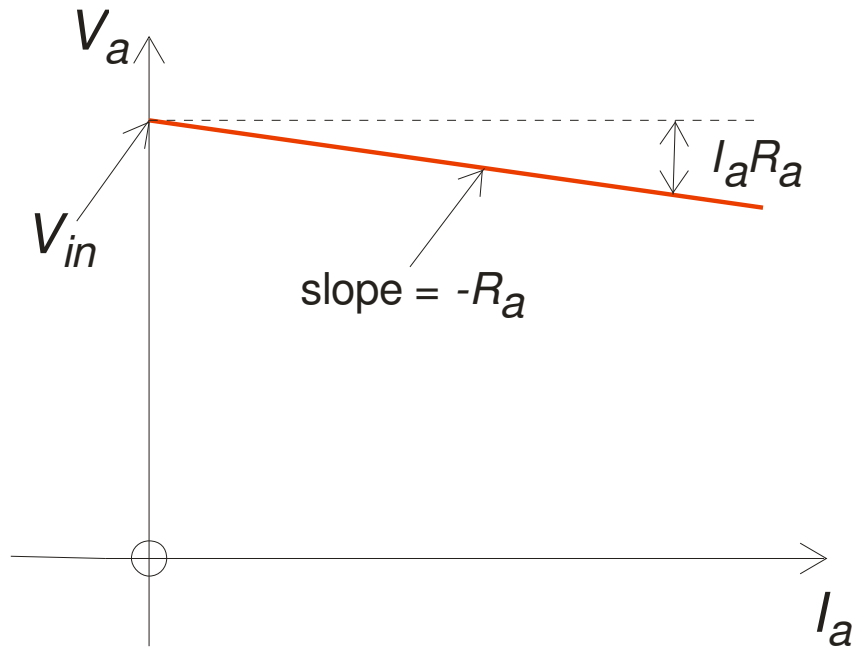

$$V_a = V_{in} - I_a R_a$$

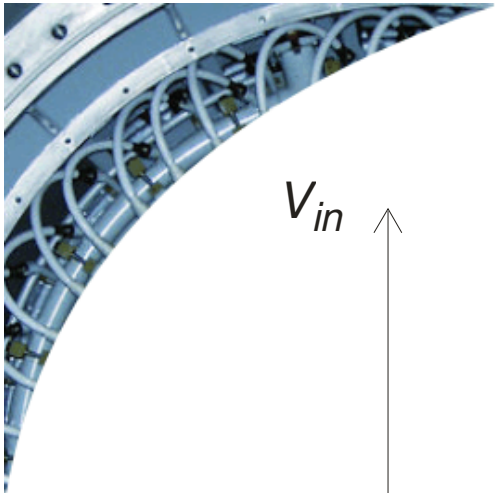

Vary n

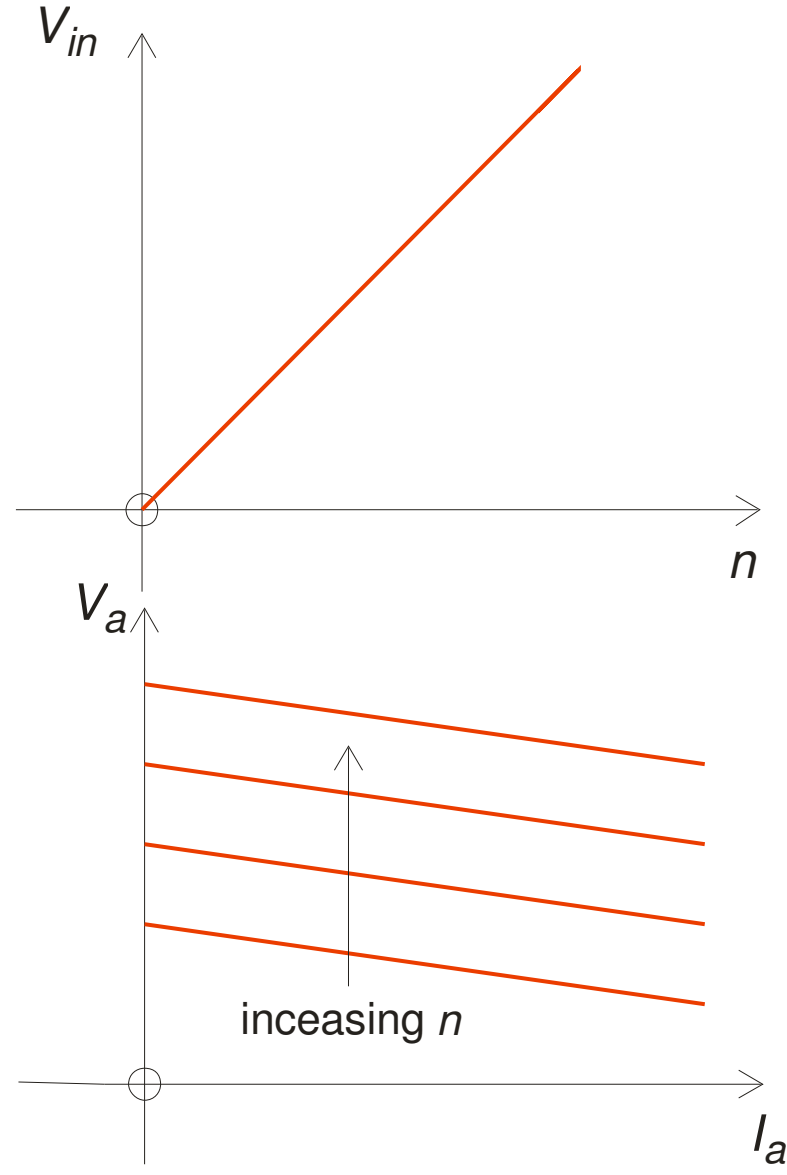

Vary I_f
no saturation

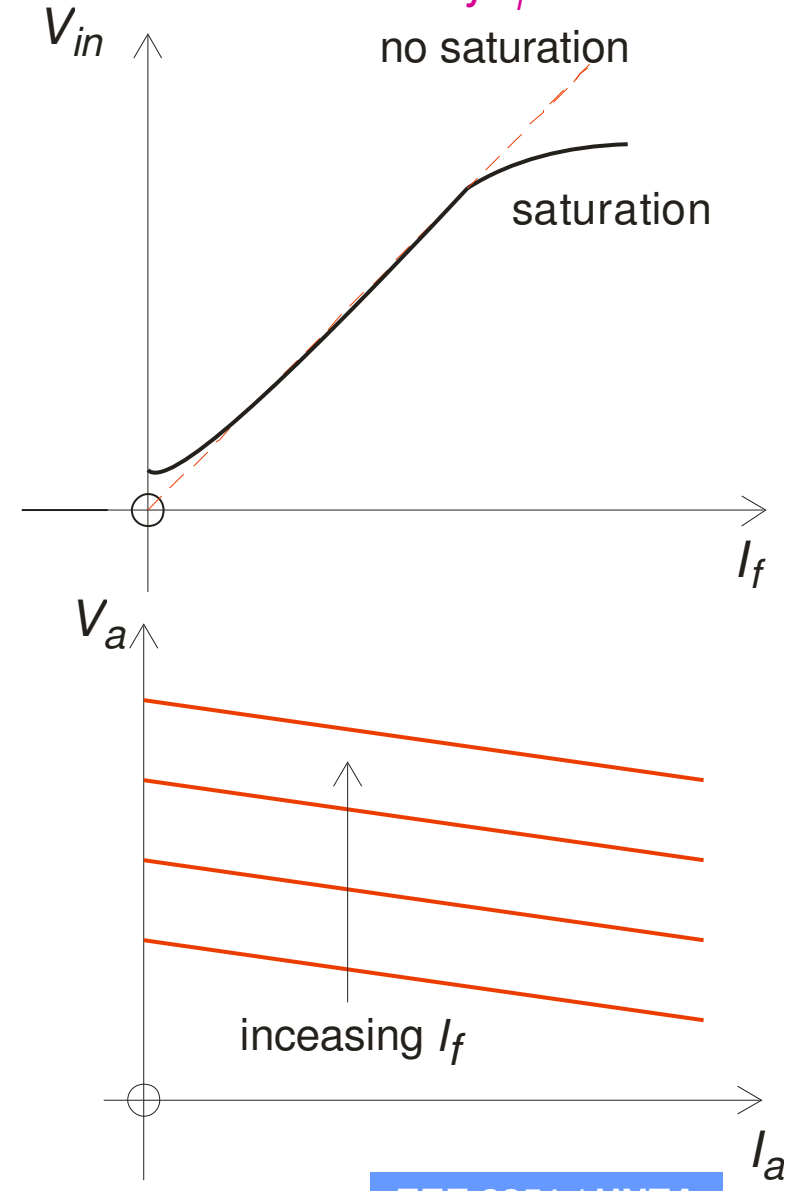

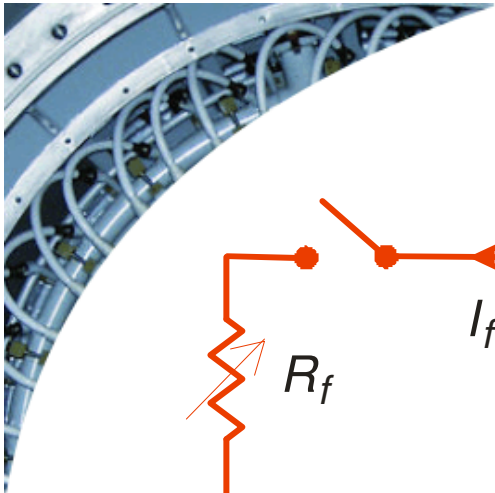

Shunt excitation

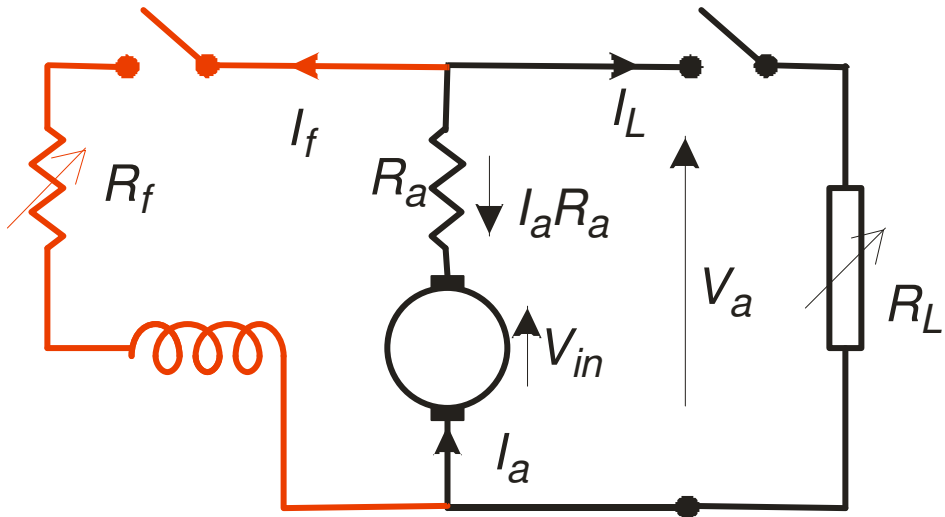

⇒ close field switch, then

$$V_f = V_a$$

⇒ on load with load switch closed

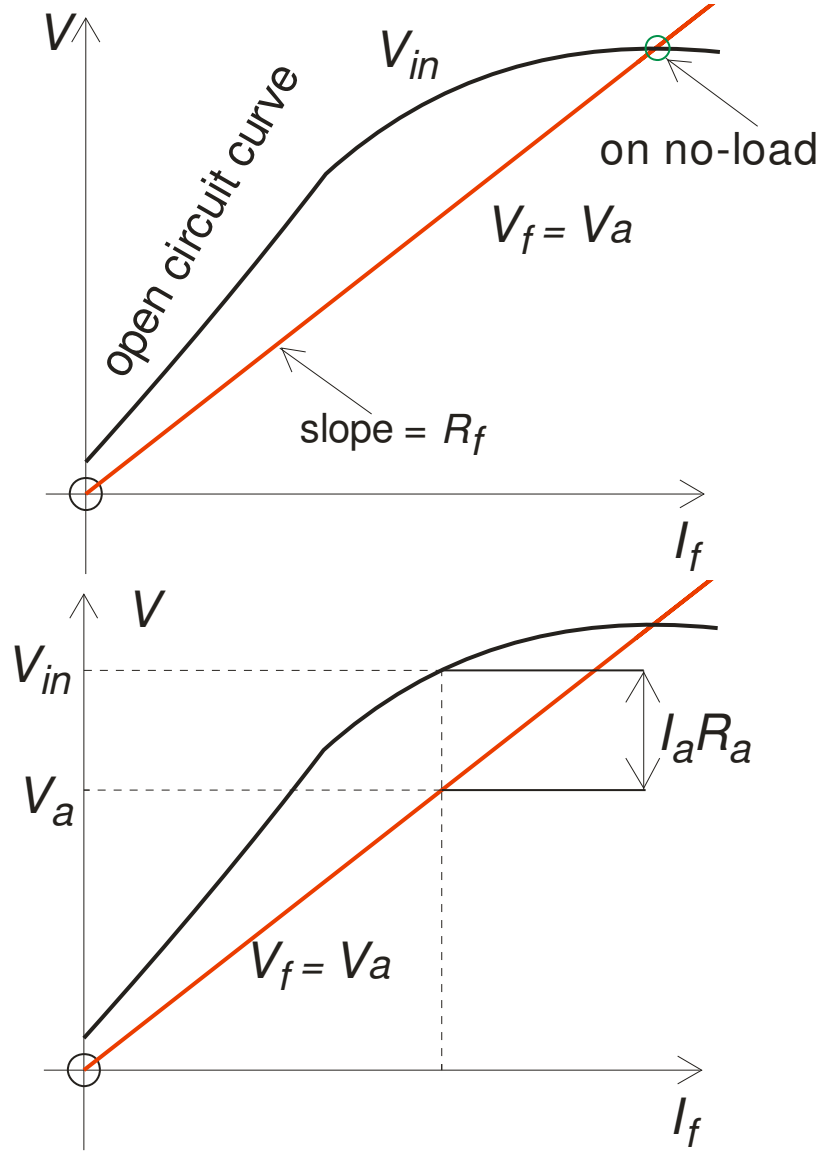

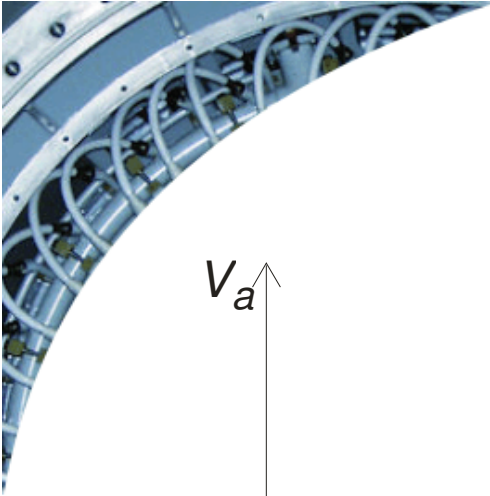

Why shunt generator may fail to self-excite

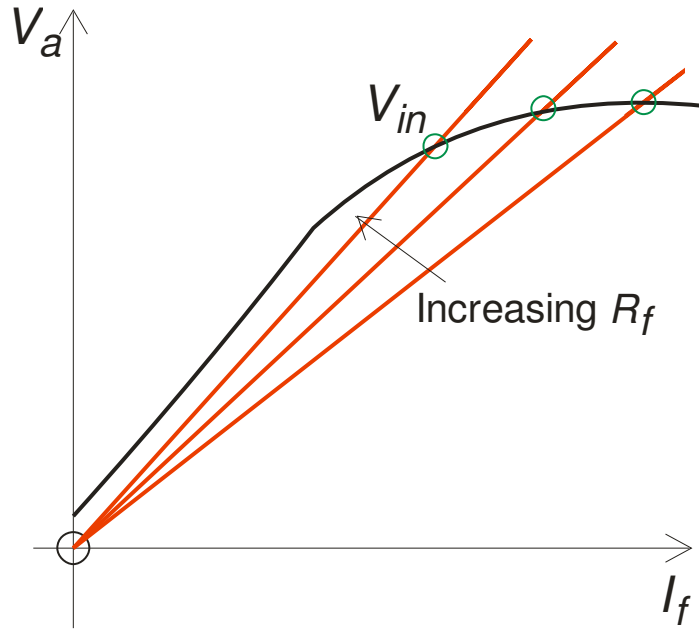

Too high R_f

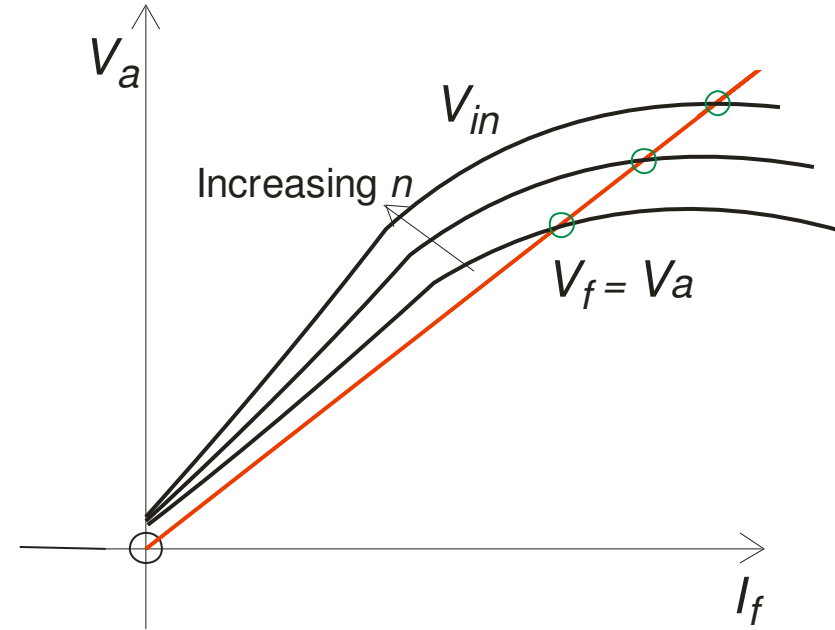

Too low n

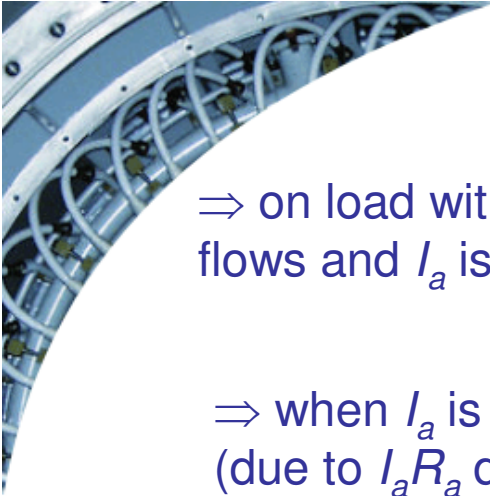

⇒ on load with load switch closed, I_L flows and I_a is significant

⇒ when I_a is increased, V_a reduces (due to $I_a R_a$ drop), as in the case of separate excitation

⇒ V_f reduces, I_f reduces, ϕ reduces (unlike in separate excitation)

⇒ $\therefore V_{in}$ reduces

⇒ V_a reduces even further

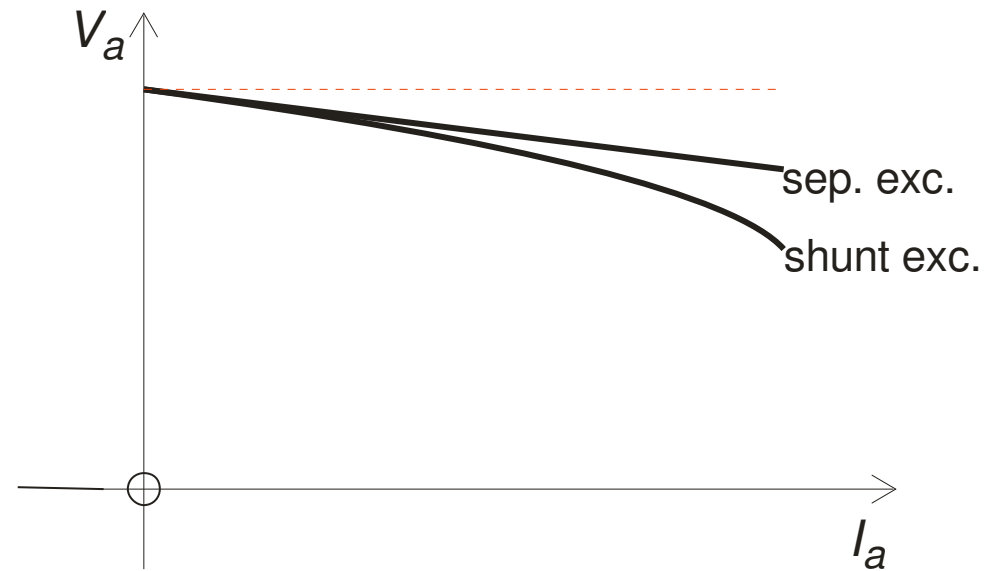

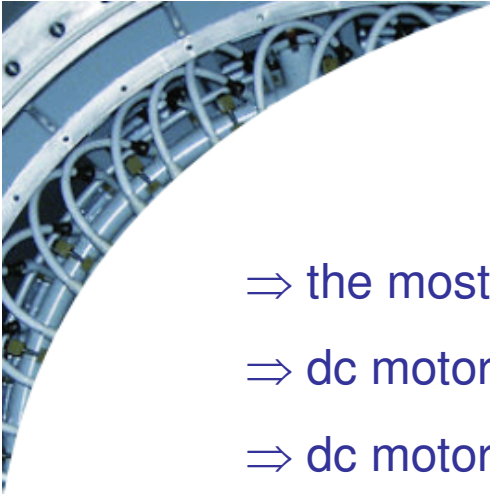

DC Motors

⇒ the most common industrial workhorse is the ac cage induction motor

⇒ dc motor is more complex and more costly

⇒ dc motor has advantage of

- a wide variety of torque-speed characteristics
- economical speed control

⇒ relationship between speed and torque corresponds to relationship between voltage and current for a generator

⇒ speed at which motor will run depends on the balancing point of the electromagnetic torque T_e and the mechanical load torque T_m

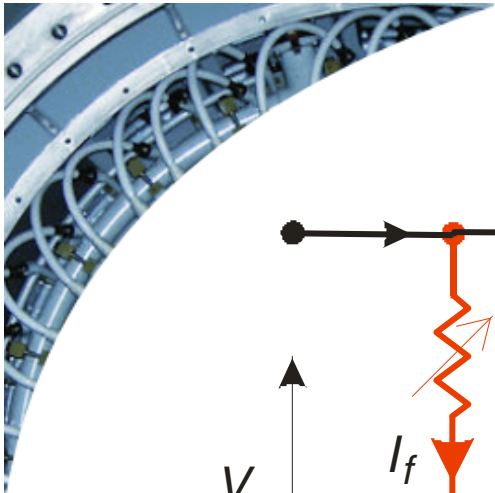

DC shunt motor

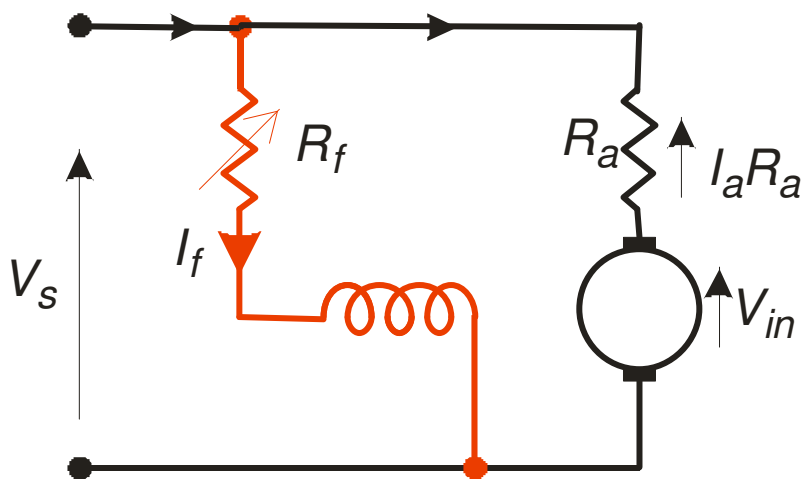

$$V_s = V_{in} + I_a R_a$$

$$T = \frac{1}{2\pi} \left(\frac{2pZ}{c} \right) \phi I_a$$

⇒ at const. I_f (∴ const. ϕ),

$$V_{in} \propto n$$

$$T \propto I_a$$

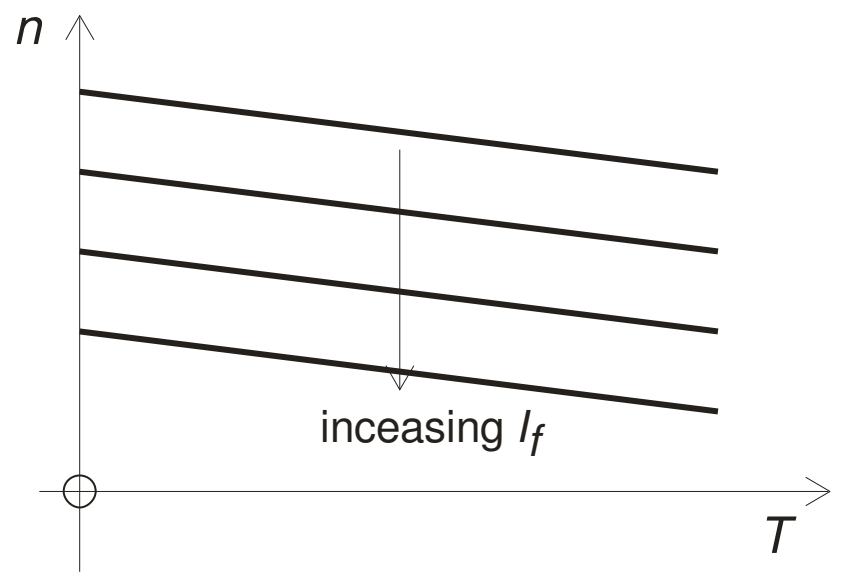
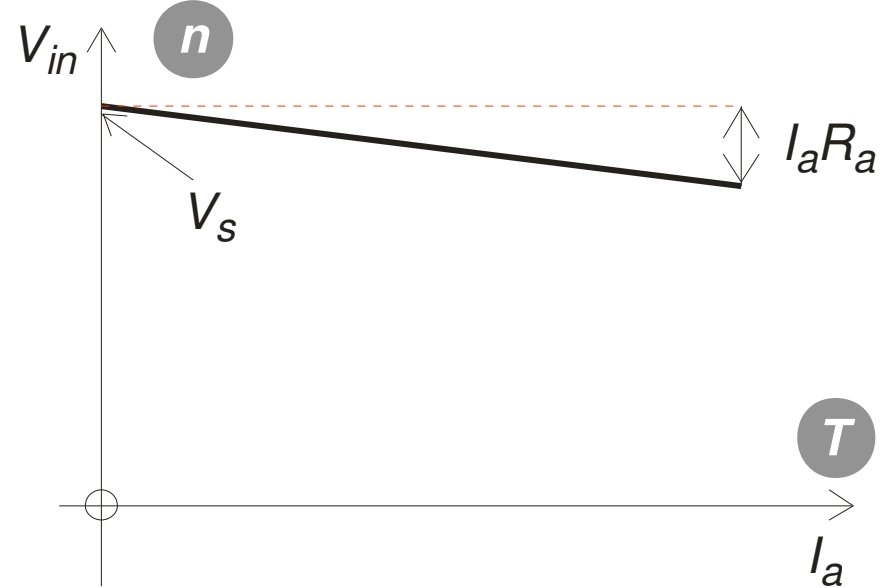

DC series motor

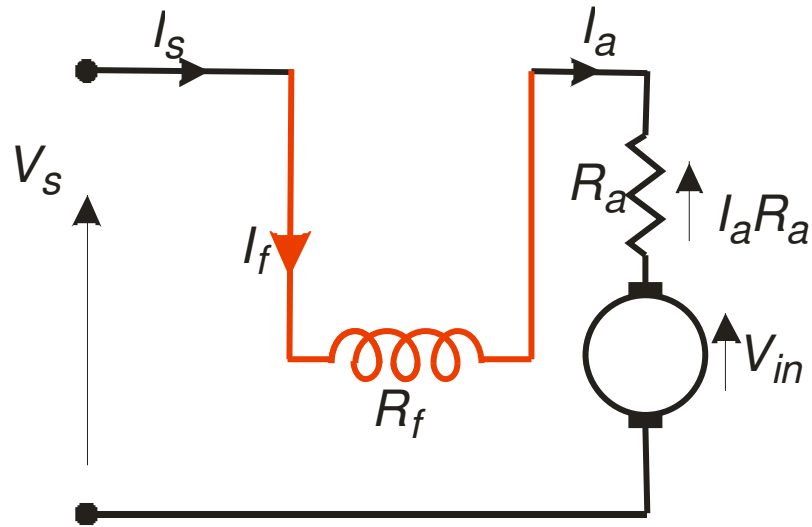

$$I_s = I_a = I_f = I$$

⇒ 2 assumptions

- neglect “ IR ” drops
- neglect saturation, so

$$\phi \propto I$$

$$V_s = V_{in} = \left(\frac{2pZ}{c} \right) n \phi$$

$$\therefore n \propto \frac{1}{\phi} \propto \frac{1}{I}$$

$$T = \frac{1}{2\pi} \left(\frac{2pZ}{c} \right) \phi I_a$$

$$T \propto I^2$$

$$T \propto \frac{1}{n^2}$$

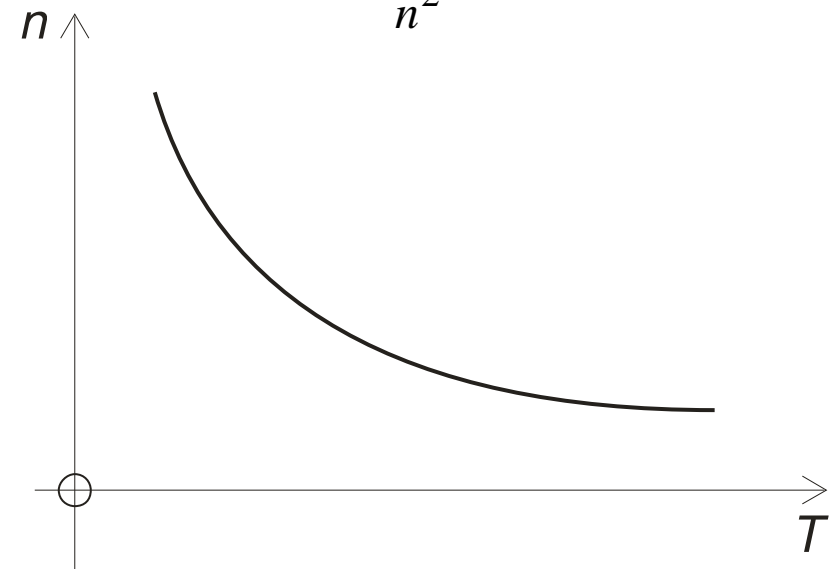

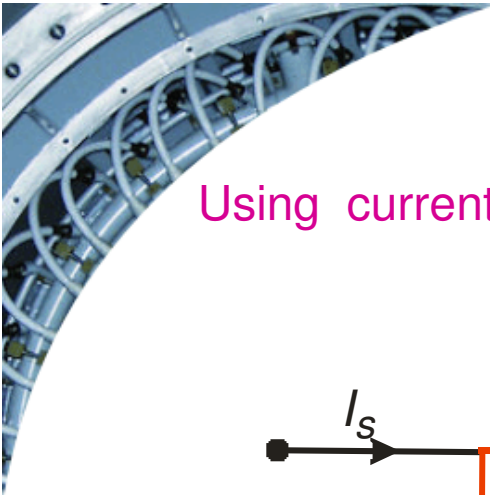

Using current diverter

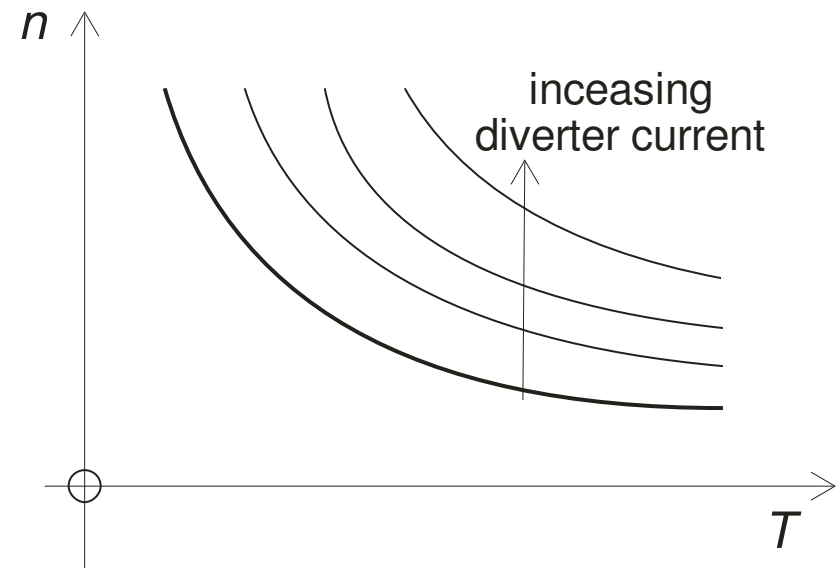
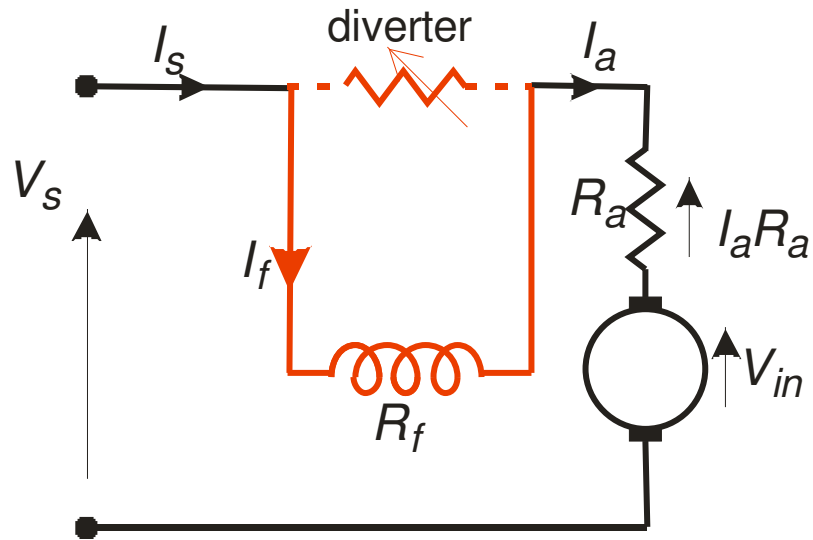

⇒ gives a family of T - n curves



Starting DC motors

$$V_s = V_{in} + I_a R_a$$

⇒ for $V_s = 220 \text{ V}$, $R_a = 1 \ \Omega$ (e.g.)

	I_a	V_s	=	V_{in}	+	$I_a R_a$
Full-load	10 A	220	=	210	+	10 x 1
No-load	1 A	220	=	219	+	1 x 1
Starting	?	220	=	0	+	? x 1

⇒ for an assumed no-load $I = 1 \text{ A}$ and full-load $I = 10 \text{ A}$, starting current is 220 A!

⇒ this is unacceptable

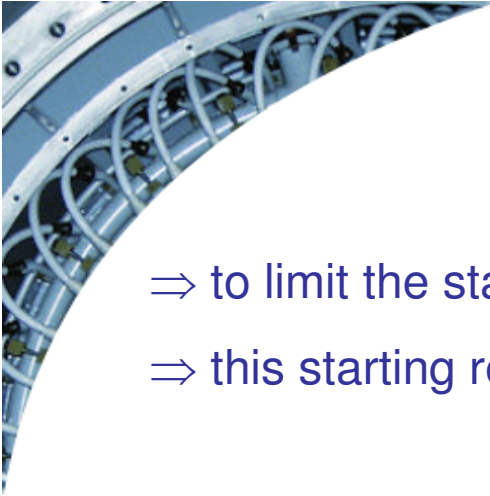

- ⇒ to limit the starting current we include a temporary resistor in the armature
- ⇒ this starting resistance is gradually reduced to zero as the machine speeds

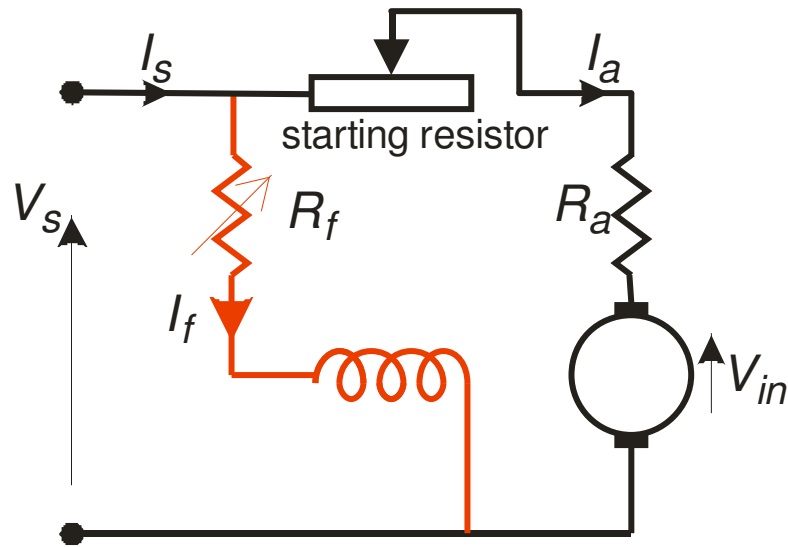



A practical manual starter

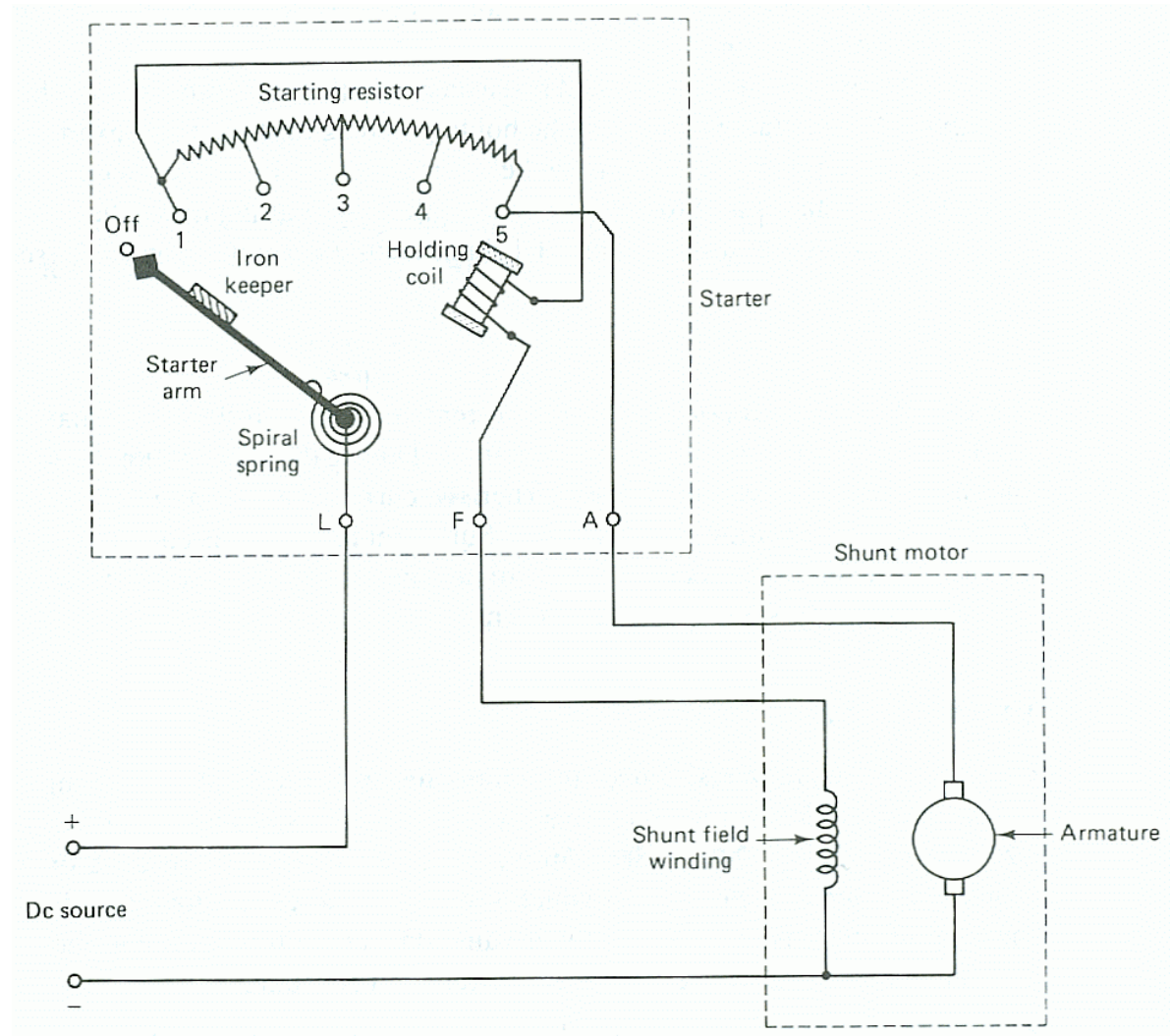

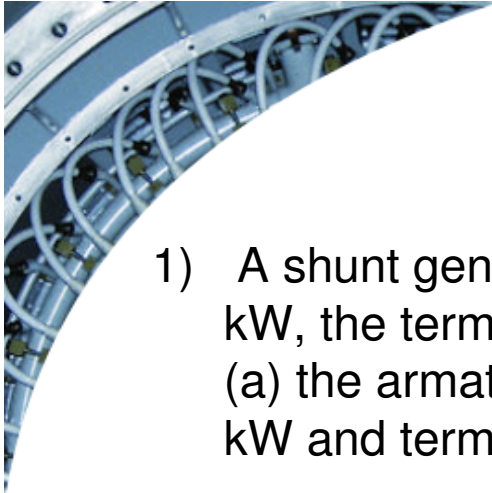

Examples

- 1) A shunt generator has a field resistance of 60Ω . when the generator delivers 6 kW, the terminal voltage is 120 V., while the generated EMF is 133 V. Determine (a) the armature circuit resistance and (b) the generated EMF when the output is 2 kW and terminal voltage is 135 V.
- 2) A DC motor operates at 1680 r/min when drawing 28 A from a 230-V supply. If the armature resistance is 0.25Ω , and assuming all losses are neglected, calculate (a) the no-load speed, (b) the developed power under loaded conditions and (c) the torque developed under the given load.
- 3) A 240-V shunt motor has an armature resistance of 0.25Ω . Under load, the armature current is 24 A. Suppose the flux is suddenly decreased by 2.5%; (a) what would be the immediate effect on the developed torque? (b) if the motor was running at 640 r/min before the field was adjusted, determine the new steady-state speed after the field has been decreased.
- 4) A 240-V shunt motor runs at 800 r/min when the armature current is 70 A. The armature circuit resistance is 0.10Ω . Calculate the required resistance to be placed in series with the armature to reduce the speed to 650 r/min when armature current is 50 A.