

EEE 3352

Electromechanics & Electrical Machines

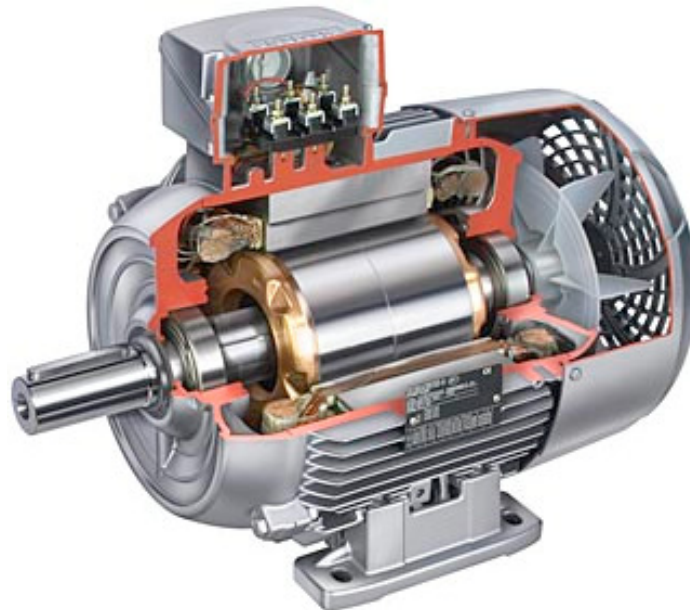

Basic Electrical Engineering



Basic Electrical Engineering

1. Basic laws
2. AC Fundamentals – principles
3. AC Fundamentals – application
4. Network Theorems
5. DC Transients



Texts

1. Alexander, C.K., & Sadiku, M.N.O., *Fundamentals of Electric Circuits*, 6th ed., 2017, McGraw-Hill Education, New York, NY, USA, ISBN 978-0-07-802822-9
2. Hughes, E., *Hughes Electrical and Electronic Technology*, 12th Ed., 2016, Pearson Education Ltd, Essex, England. ISBN 9781292093048



1. Basic laws

1. Ohm's law
2. Kirchhoff's voltage and current law
3. Nodes, branches and loops
4. Series elements and Voltage Division
5. Parallel elements and Current Division
6. Star-Delta transformation
7. Independent and Dependent sources
8. Source transformations

1.1 Ohm's Law

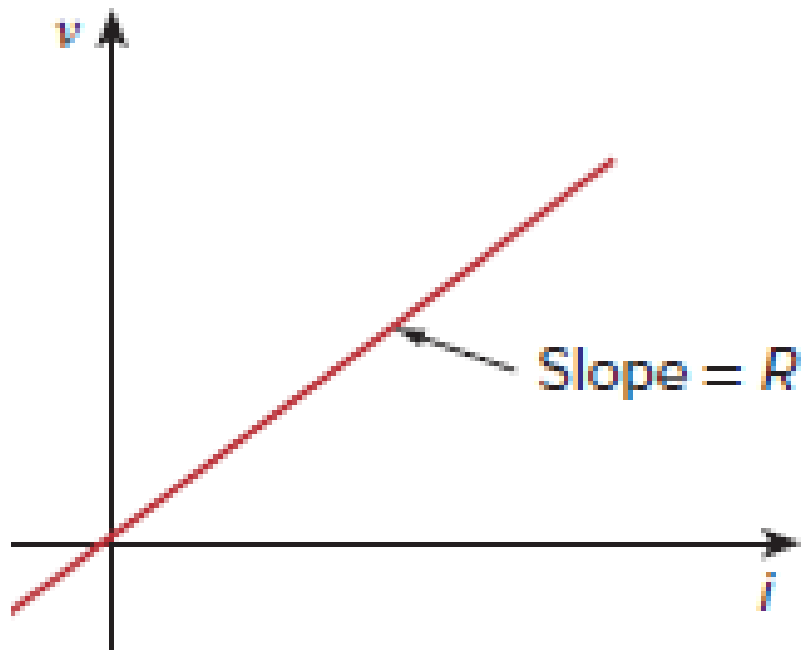

$$v \propto i$$

$$v = Ri$$

$$v = Zi$$

- the *voltage* across the *resistance* is proportional to the *current* flowing through the resistance

1.2 Kirchhoff's voltage and current law

a. Current law

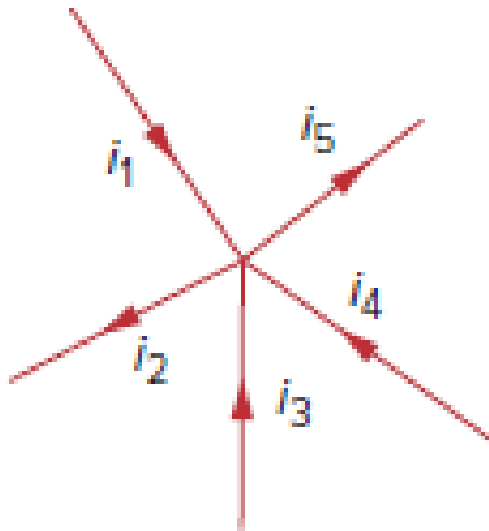

$$i_1 + i_2 + i_3 + \dots + i_n = 0$$

$$\sum_{n=1}^N i_n = 0$$

- the algebraic *sum* of the currents entering a node is *zero*

b. Voltage law

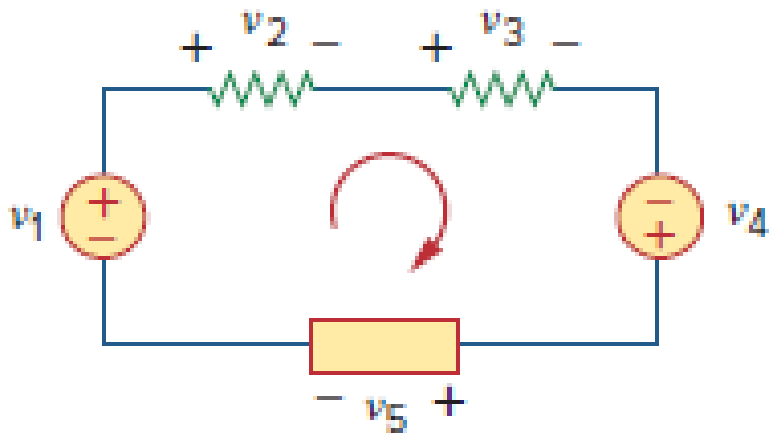

$$v_1 + v_2 + v_3 + \dots + v_n = 0$$

$$\sum_{m=1}^M v_m = 0$$

- the algebraic *sum* of the voltages around a closed path (or loop) is *zero*

1.3 Nodes, branches and loops

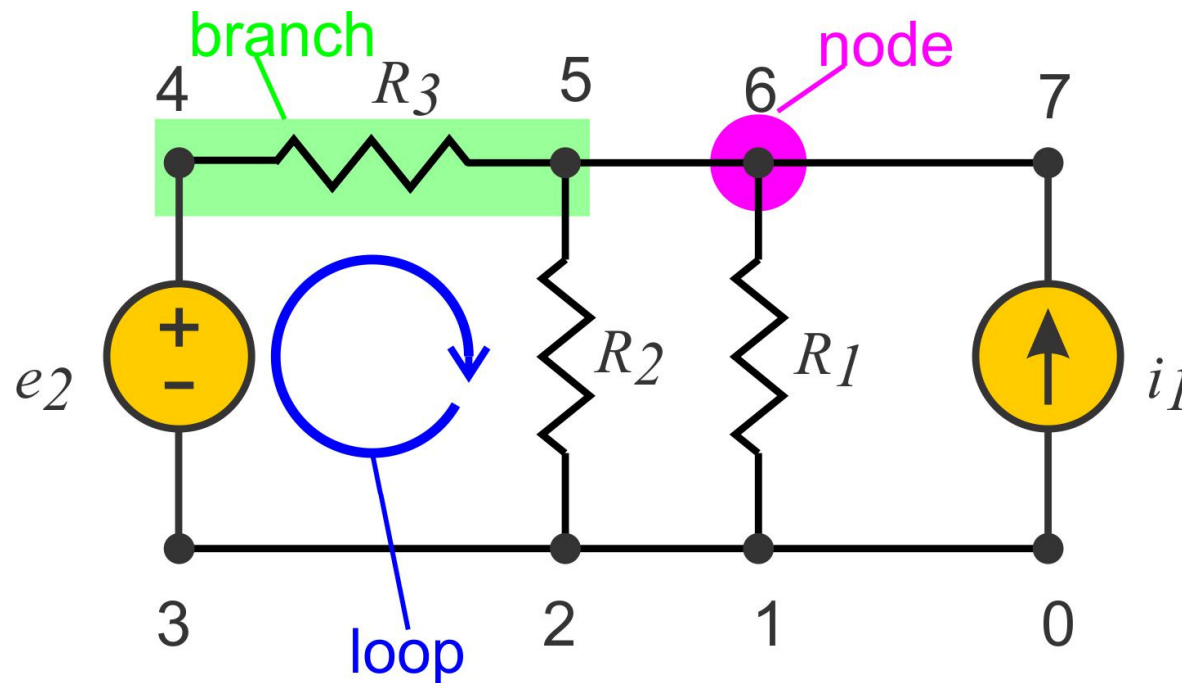

$$b = l + n - 1$$

- branch, b : single element
- node, n : point of connection of 2 or more branches
- loop, l : any closed path in a circuit

1.4 Series elements and Voltage Division

a. Series connected elements

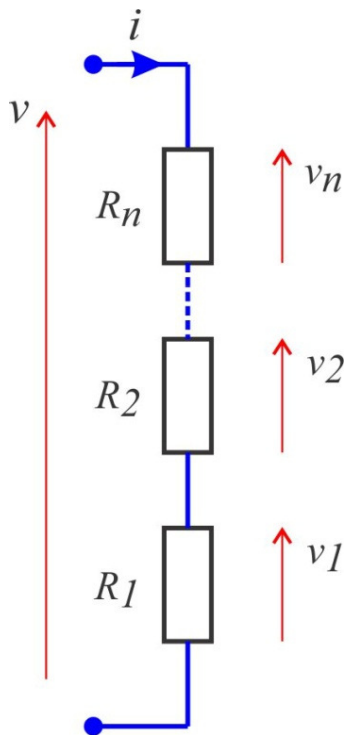

$$v = v_1 + v_2 + \dots + v_n$$

$$R = R_1 + R_2 + \dots + R_n$$

b. Voltage divider

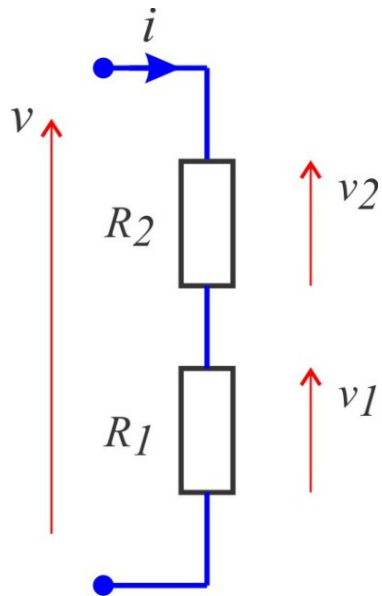

$$v_1 = v \cdot \frac{R_1}{R} = v \cdot \frac{R_1}{R_1 + R_2}$$

$$v_2 = v \cdot \frac{R_2}{R} = v \cdot \frac{R_2}{R_1 + R_2}$$

1.5 Parallel elements and Current Division

a. Parallel connected elements

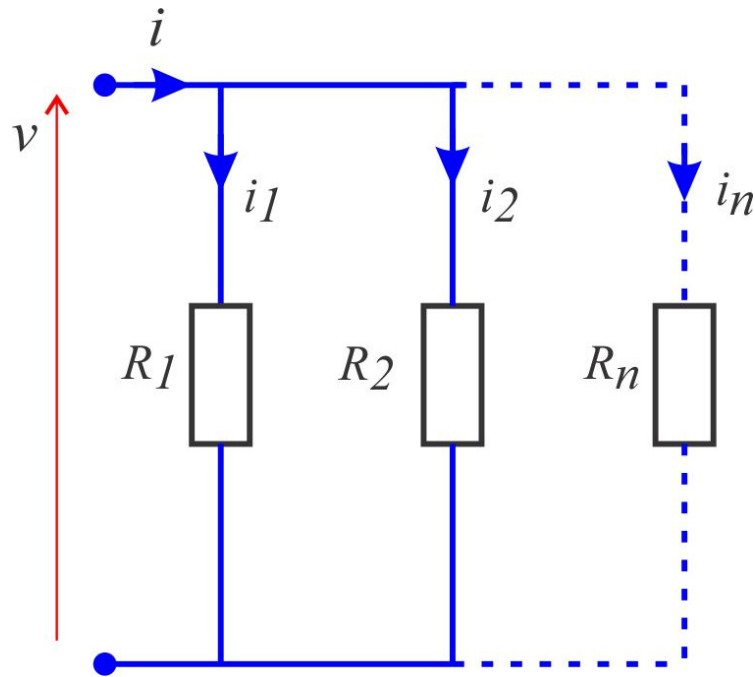

$$i = i_1 + i_2 + \dots + i_n$$

$$\frac{1}{R} = \frac{1}{R_1} + \frac{1}{R_2} + \dots + \frac{1}{R_n}$$

b. Current divider

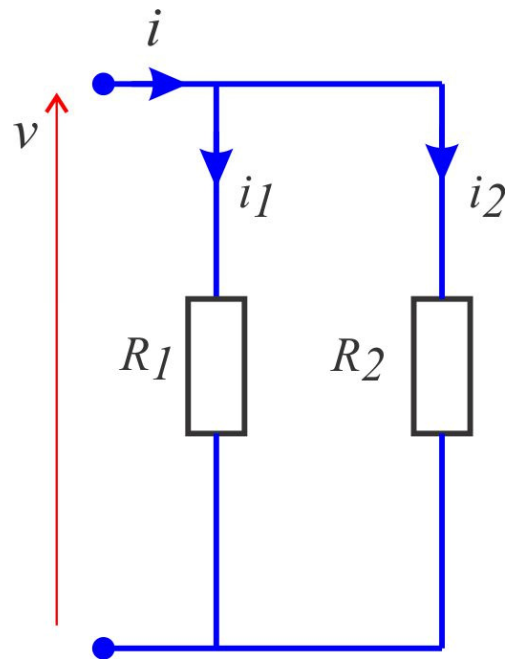

$$i_1 = i \cdot \frac{R_2}{R_1 + R_2}$$

$$i_2 = i \cdot \frac{R_1}{R_1 + R_2}$$

1.6 Star-Delta transformation

delta

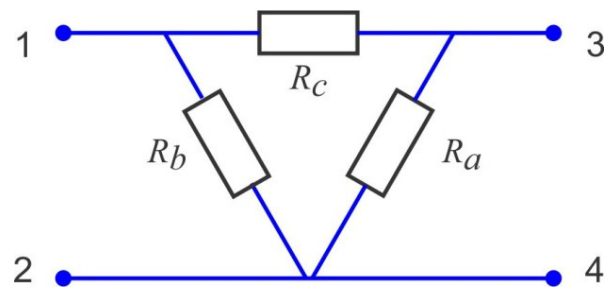

star

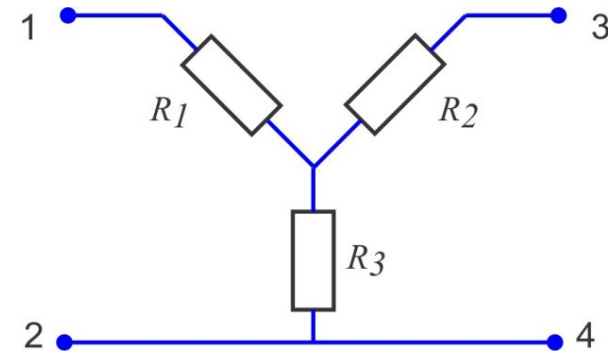

Π (pi)

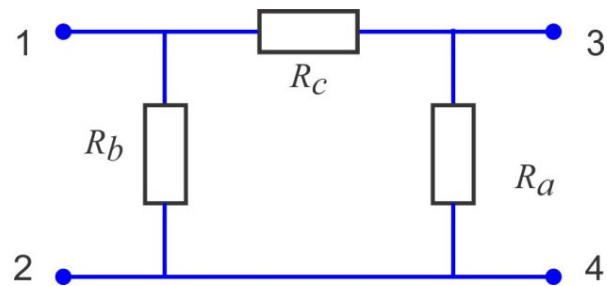

T

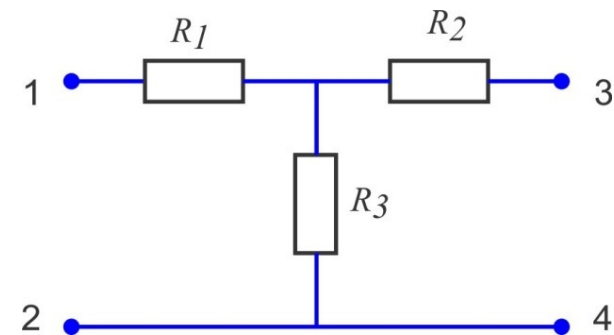

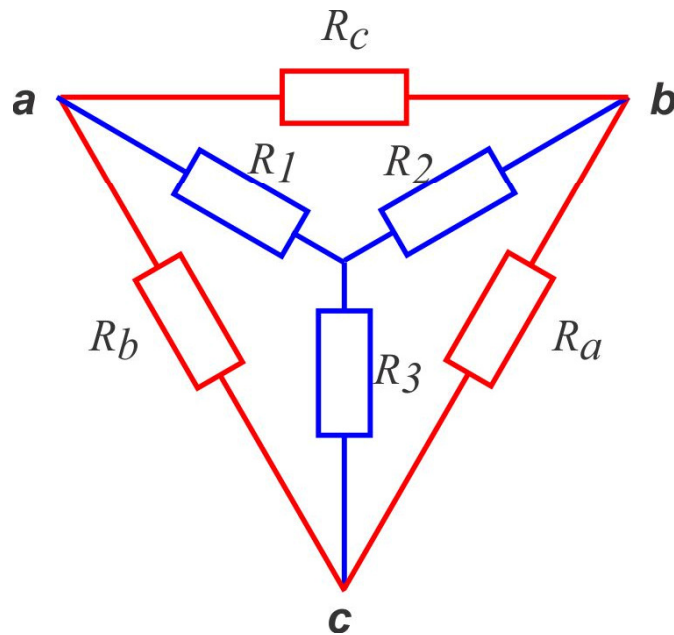
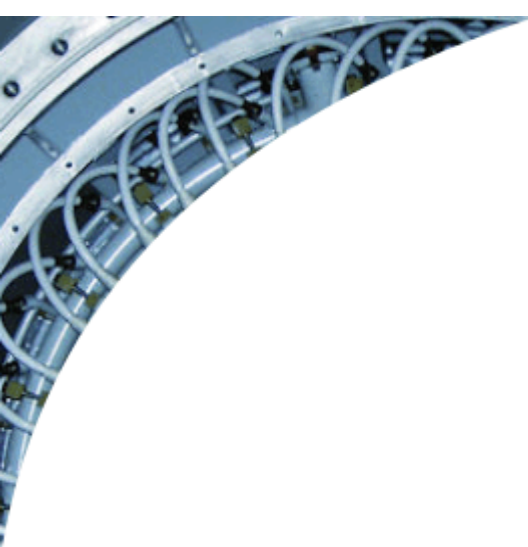

delta to star

$$R_1 = \frac{R_b R_c}{R_a + R_b + R_c}$$

$$R_2 = \frac{R_c R_a}{R_a + R_b + R_c}$$

$$R_3 = \frac{R_c R_a}{R_a + R_b + R_c}$$

star to delta

$$R_a = \frac{R_1 R_2 + R_2 R_3 + R_3 R_1}{R_1}$$

$$R_b = \frac{R_1 R_2 + R_2 R_3 + R_3 R_1}{R_2}$$

$$R_c = \frac{R_1 R_2 + R_2 R_3 + R_3 R_1}{R_3}$$

1.7 Independent and Dependent sources

a. Independent ideal V - I source

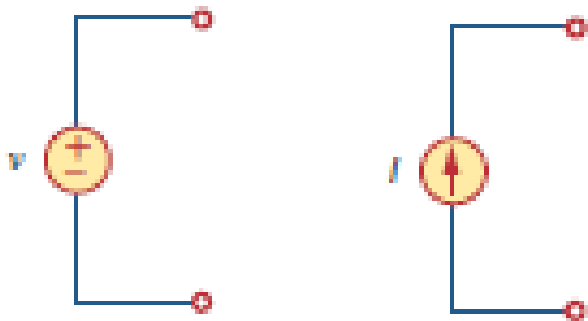

b. dependent ideal V - I source

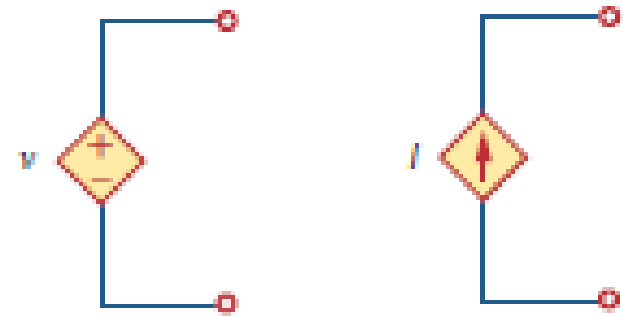

1.8 Source transformations

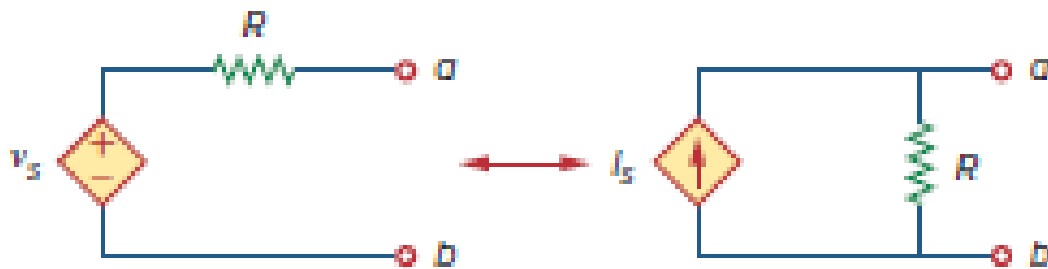
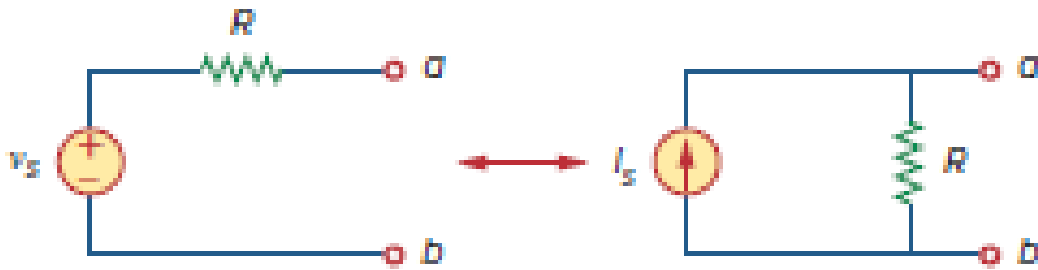

$$v_s = i_s R$$

$$i_s = \frac{v_s}{R}$$



2. AC Fundamentals - principles

1. Review of complex algebra
2. Sinusoids
3. Phasors
4. Phasor relations of circuit elements
5. Impedance and admittance
6. Impedance combinations
7. Series and parallel combination of L & C
8. Mesh analysis and nodal analysis

2.1 Review of complex algebra

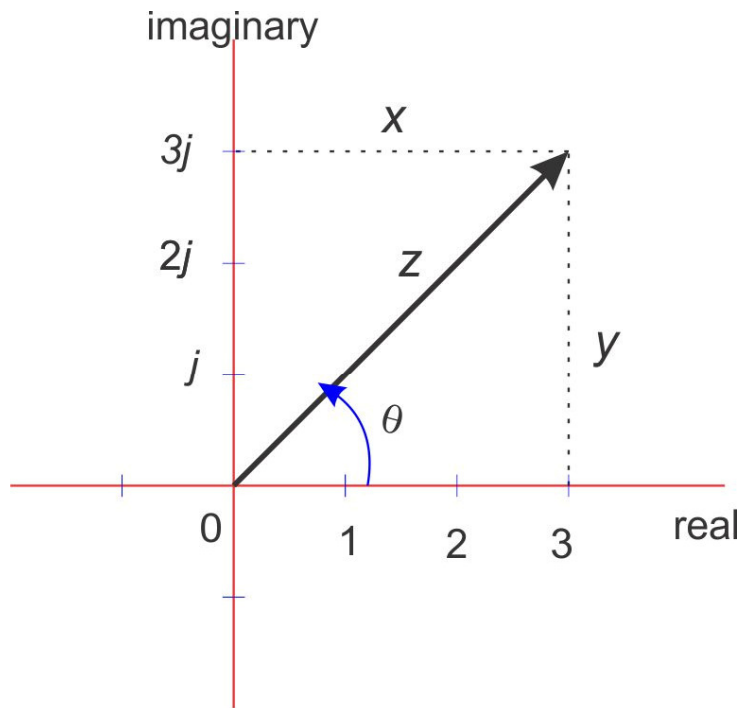

$$z = x + jy$$

$$x = r \cos \theta$$

$$y = r \sin \theta$$

$$\theta = \tan^{-1} \left(\frac{y}{x} \right)$$

Other representations

$$z = r \angle \theta$$

$$r = \sqrt{x^2 + y^2}$$

$$z = re^{j\theta}$$

2.2 Sinusoids

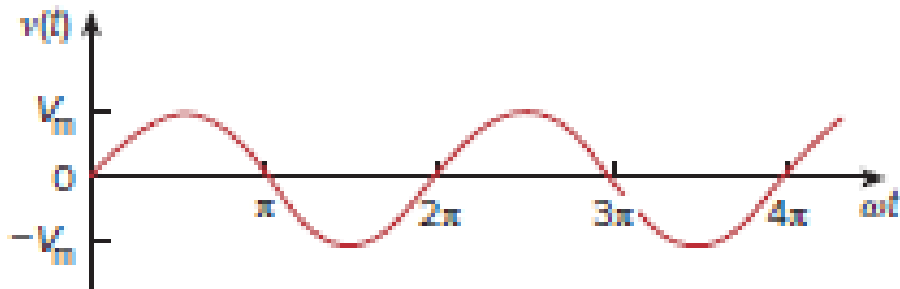
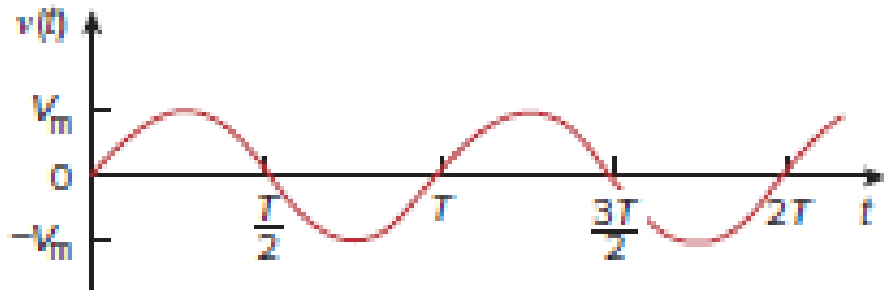

$$v(t) = V_m \cos \omega t$$

$$\omega T = 2\pi$$

$$f = \frac{1}{T}$$

$$v(t + T) = v(t)$$

2 sinusoids

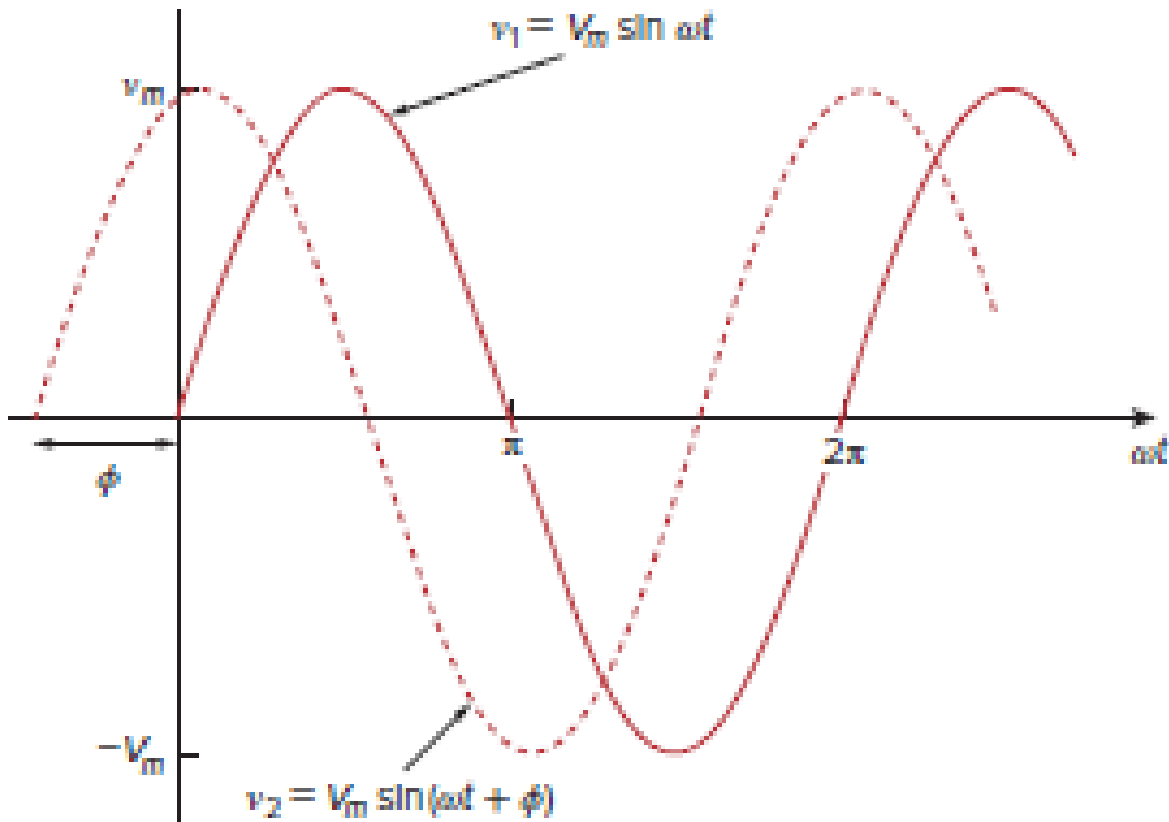

graphical representation

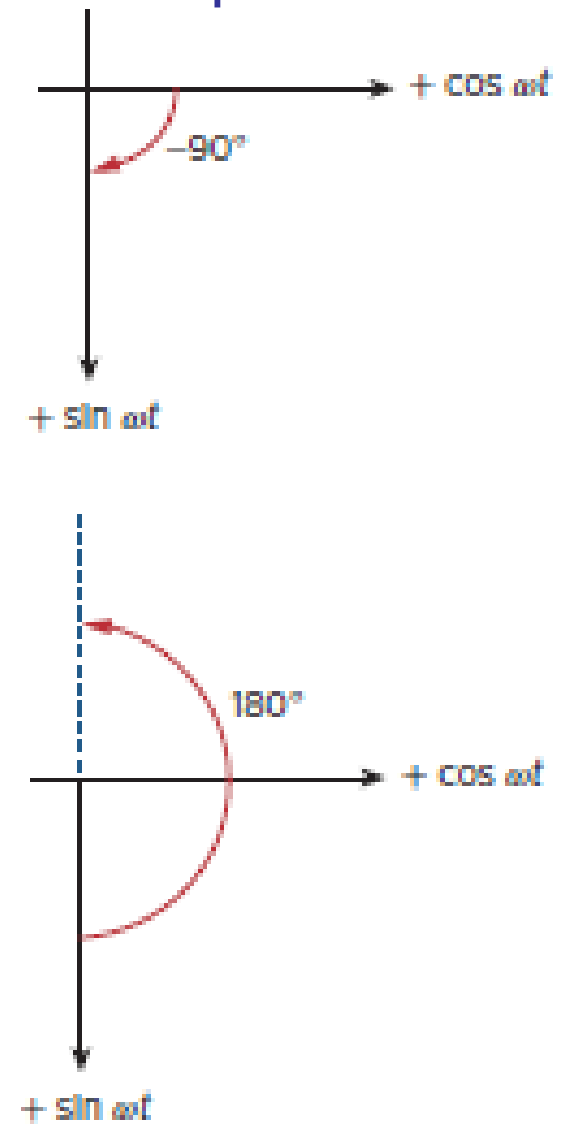

2.3 Phasors

- a complex number that represents the amplitude and phase of sinusoid

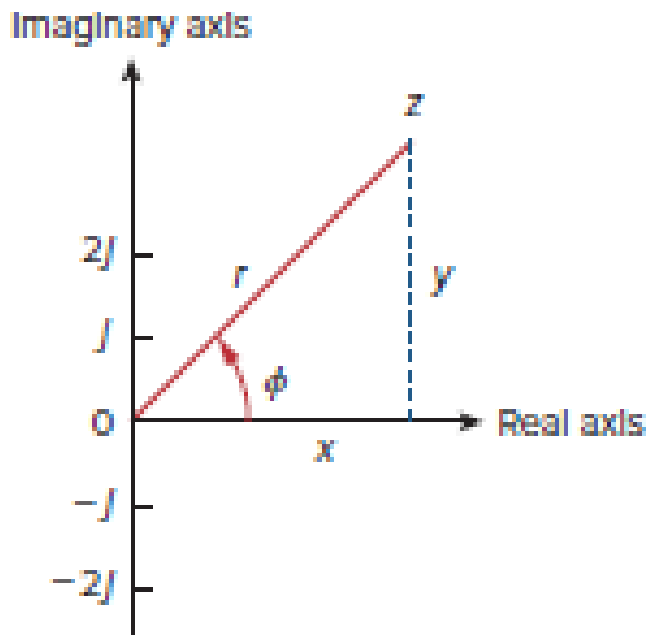

$$z = x + jy = r \angle \theta = r(\cos \theta + j \sin \theta)$$

phasor domain

$$\mathbf{V} = V_m \angle \phi$$

time domain

$$v(t) = V_m (\cos \omega t + \phi)$$

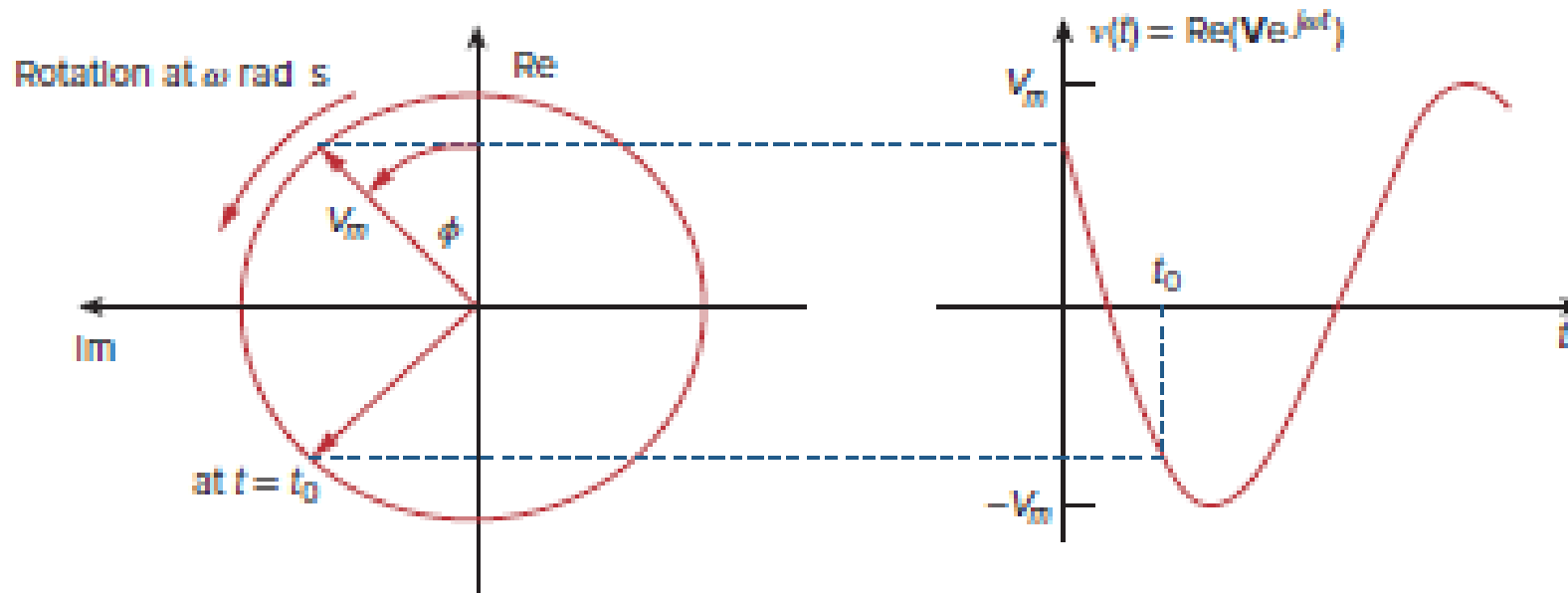

2.4 Phasor relations of circuit elements

a. resistance

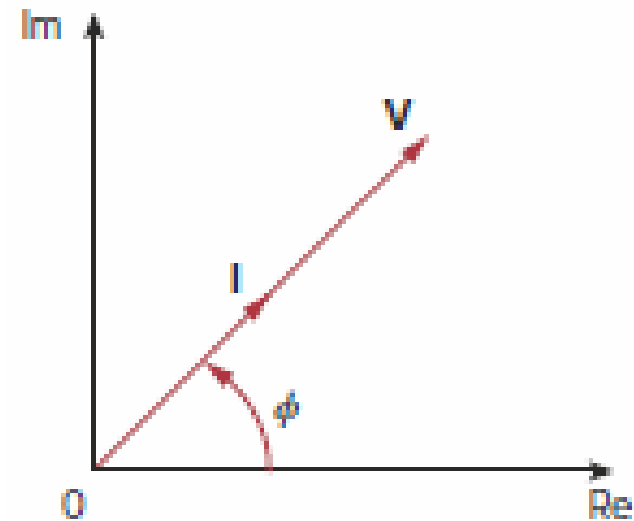
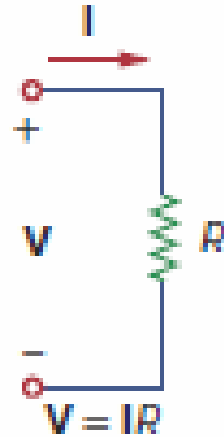
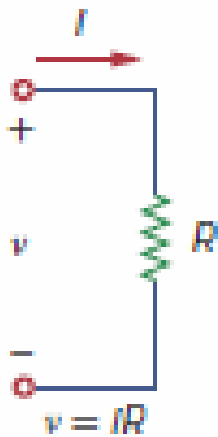

b. inductance

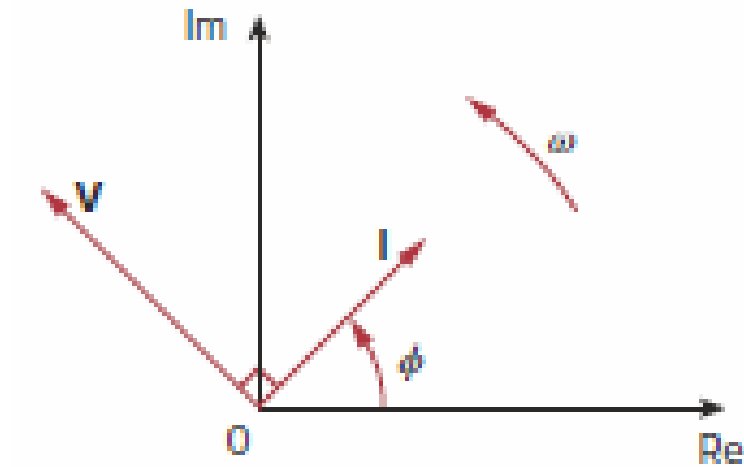
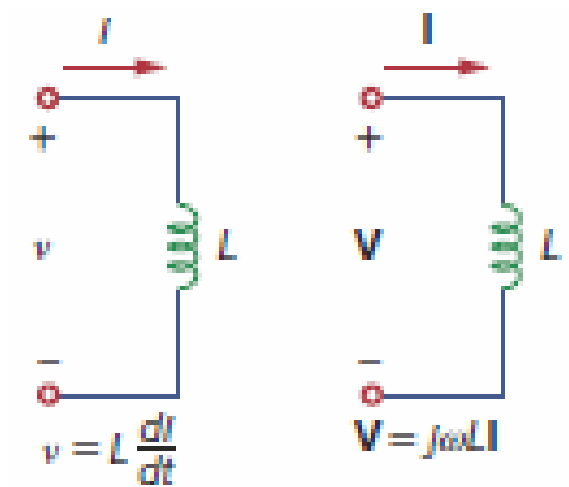

c. capacitance

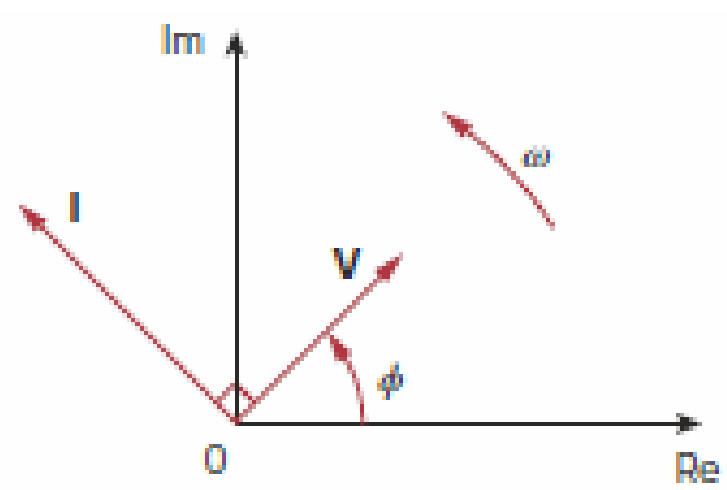
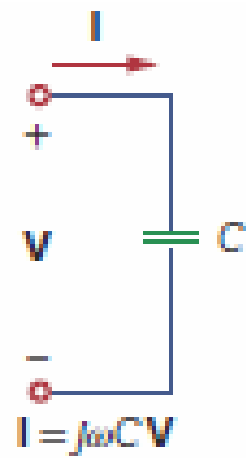
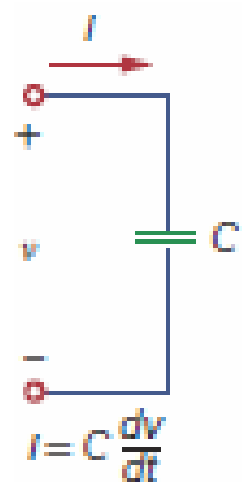

Summary

Element	Time domain	Frequency domain
R	$v = Ri$	$V = RI$
L	$v = L \frac{di}{dt}$	$V = j\omega LI$
C	$i = C \frac{dv}{dt}$	$V = \frac{I}{j\omega C}$

2.5 Impedance and admittance

Ohm's law

$$\mathbf{V} = \mathbf{Z}\mathbf{I}$$

impedance

$$\mathbf{Z} = \frac{\mathbf{V}}{\mathbf{I}}$$

$$\mathbf{Z} = R \pm jX$$

X = reactance

inductive reactance: $X = X_L = j\omega L$

capacitive reactance: $X = X_C = \frac{1}{j\omega C} = -j\frac{1}{\omega C}$



admittance

$$\mathbf{Y} = \frac{\mathbf{I}}{\mathbf{V}}$$

$$\mathbf{Y} = G + jB$$

G = conductance

B = susceptance



2.6 Impedance combinations

Kirchhoff's laws

series combination

parallel combination

star-delta transformation

voltage divider

current divider

same as with resistances

2.7 Series and parallel combination of L & C

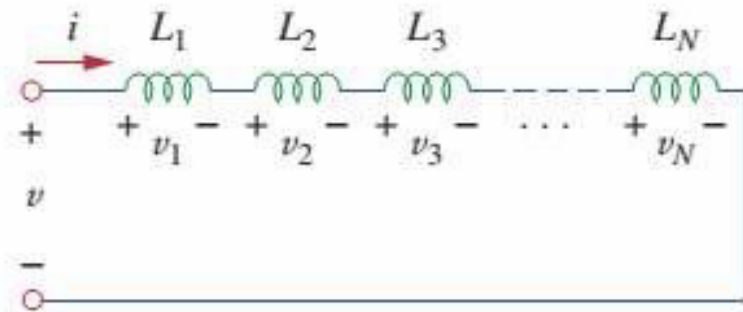

\Rightarrow

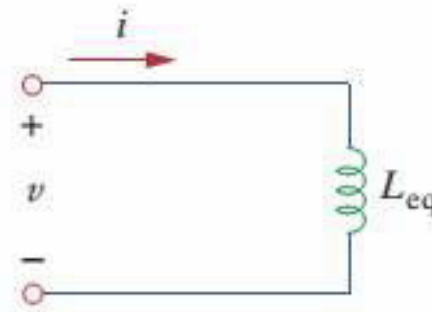

series L

$$L_{eq} = L_1 + L_2 + L_3 \dots + L_N$$

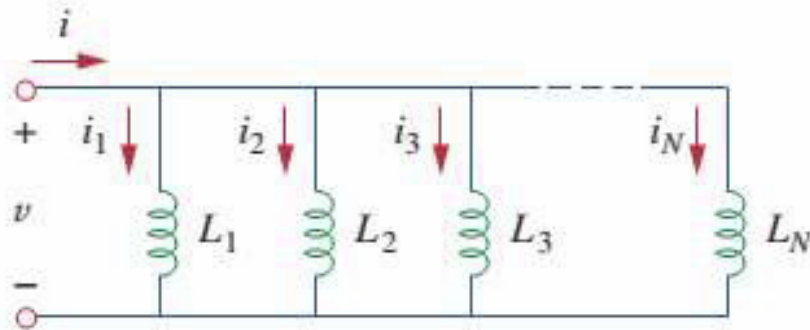

\Rightarrow

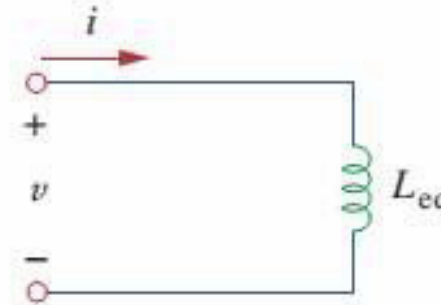

parallel L

$$\frac{1}{L_{eq}} = \frac{1}{L_1} + \frac{1}{L_2} + \frac{1}{L_3} \dots + \frac{1}{L_N}$$

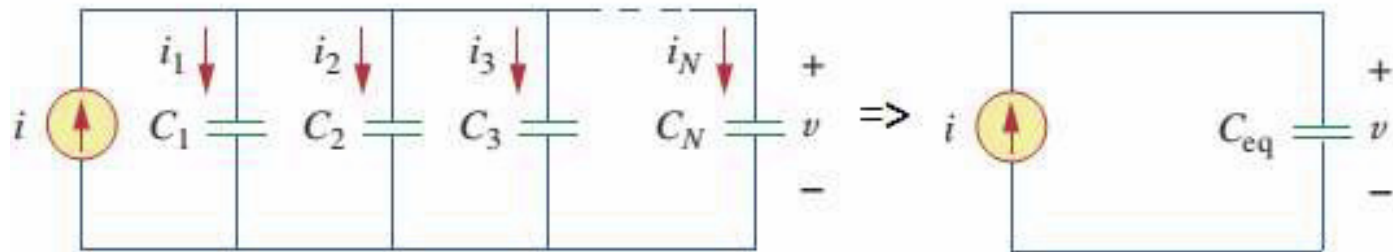
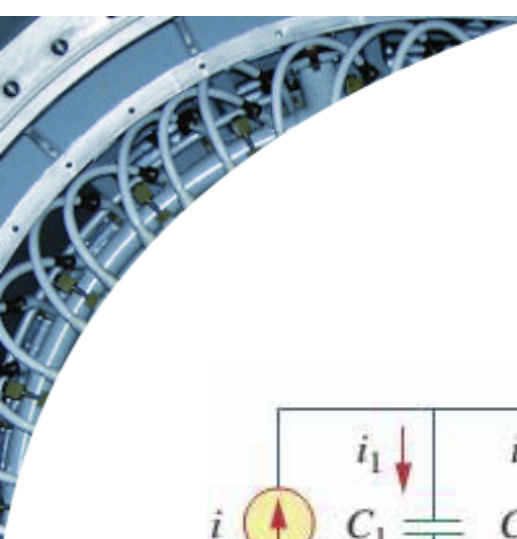

parallel C

$$C_{eq} = C_1 + C_2 + C_3 \dots + C_N$$

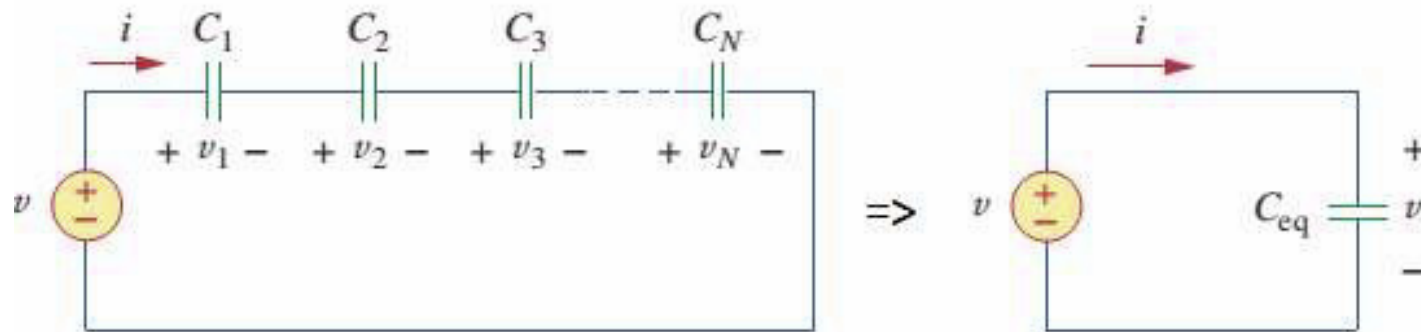

series C

$$\frac{1}{C_{eq}} = \frac{1}{C_1} + \frac{1}{C_2} + \frac{1}{C_3} \dots + \frac{1}{C_N}$$



2.8 Mesh analysis and nodal analysis

Mesh analysis

1. determine the number of meshes n
2. assign mesh current i_1, i_2, \dots, i_n , to the n meshes.
3. denote the voltage drop polarities.
4. apply KVL to each of the n meshes.
5. solve the resulting n simultaneous equations to get the mesh currents



Nodal analysis

1. determine the number of nodes n
2. select a node as reference node; assign voltages V_1, V_2, \dots, V_{n-1} to the remaining $n-1$ nodes
3. apply KCL to each of the $n-1$ non reference nodes
4. solve the resulting simultaneous equations to obtain the unknown node voltages



3. AC Fundamentals - application

1. RMS and average values
2. Form factor
3. Steady state analysis of R-L-C
4. AC power
5. Power factor
6. Effect of frequency

3.1 RMS and average values

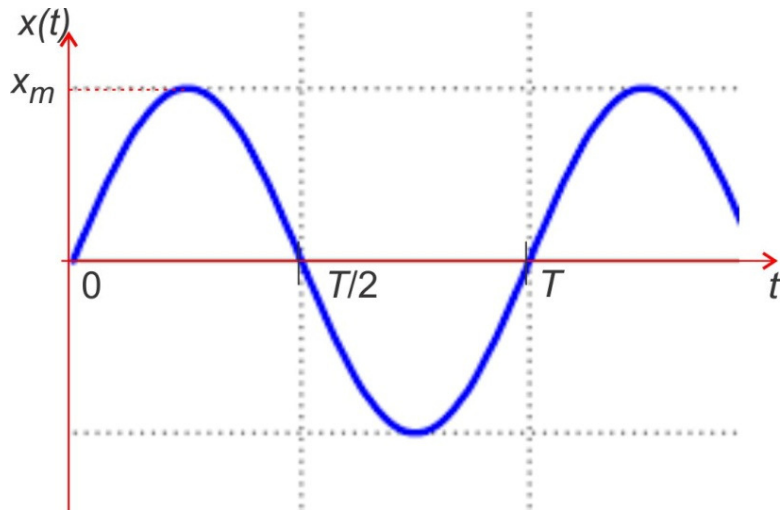

$$x_{av} = \frac{1}{T} \int_0^T x(t) dt$$

$$x_{av} = \frac{1}{2T} \int_0^T x(t) dt$$

$$X = x_{rms} = \sqrt{\frac{1}{T} \int_0^T x(t)^2 dt}$$

sinusoidal

$$x_{av} = 0$$

$$x_{av} = \frac{2}{\pi} x_m$$

$$x_{rms} = \frac{x_m}{\sqrt{2}}$$

3.2 Form factor

$$FF = \frac{x_{rms}}{x_{av}}$$

sinusoidal

$$FF = 1.11$$



3.3 Steady state analysis of R-L-C circuits

1. transform circuit to phasor or frequency domain
2. solve using circuit techniques (nodal, mesh, etc)
3. transform resulting phasor to time domain

3.4 AC Power

$$v(t) = V_m \sin(\omega t + \theta_v) \quad | \quad i(t) = I_m \sin(\omega t + \theta_i)$$

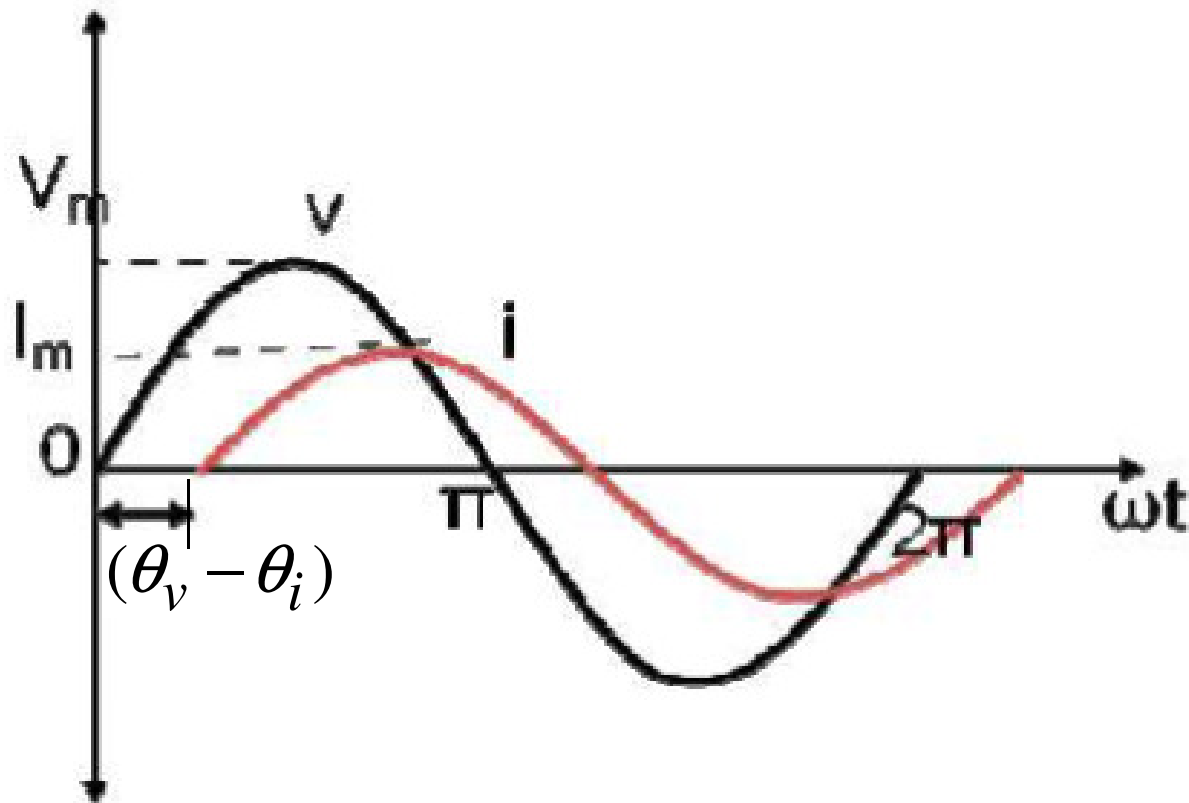

$$p(t) = v(t)i(t) = \frac{1}{2}V_m I_m \cos(\theta_v - \theta_i) + \frac{1}{2}V_m I_m \cos 2\omega t$$

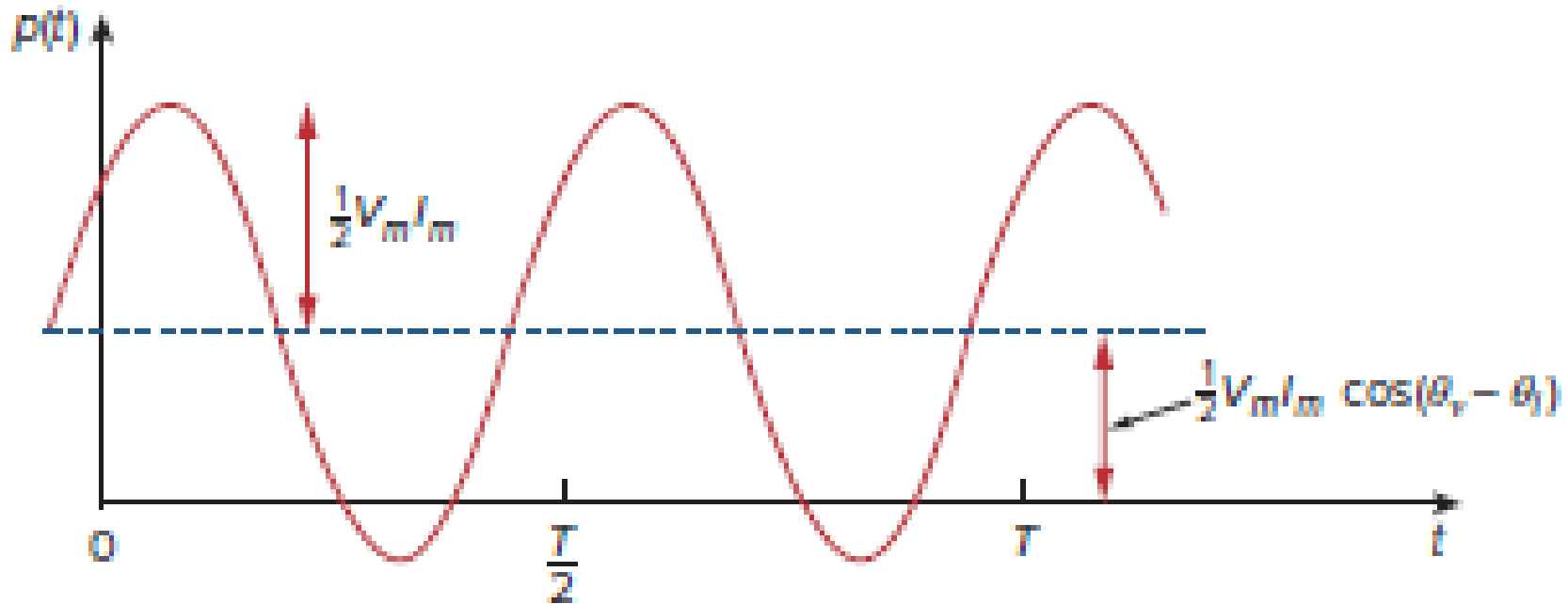

$$P_{av} = \frac{1}{2}V_m I_m \cos(\theta_v - \theta_i) = v_{rms} i_{rms} \cos(\theta_v - \theta_i) = VI \cos \theta$$



real (active)

$$P = V \times I \cos \theta = I^2 R$$

imaginary (reactive)

$$Q = V \times I \sin \theta = I^2 X$$

complex (apparent)

$$S = V \times I = I^2 Z = \sqrt{P^2 + Q^2}$$

power triangle

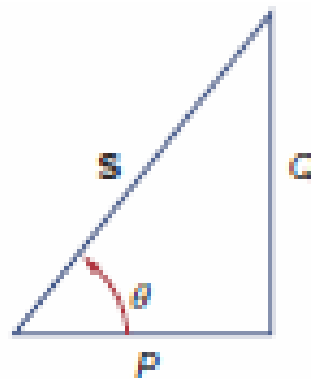



3.5 Power factor

$$\text{p.f.} = \cos \theta = \frac{P}{S}$$

Lagging pf: inductive circuit

Leading pf: capacitive circuit

3.6 Effect of frequency

increasing f :

- increases X_L
- reduces X_C
- no effect on R

resonance (series): $X_L = X_C$

$$f_0 = \frac{1}{2\pi} \frac{1}{\sqrt{LC}}$$



4. Network Theorems

1. Superposition theorem
2. Thevenin's theorem
3. Norton's theorem
4. Maximum Power Transfer Theorem

4.1 Superposition theorem

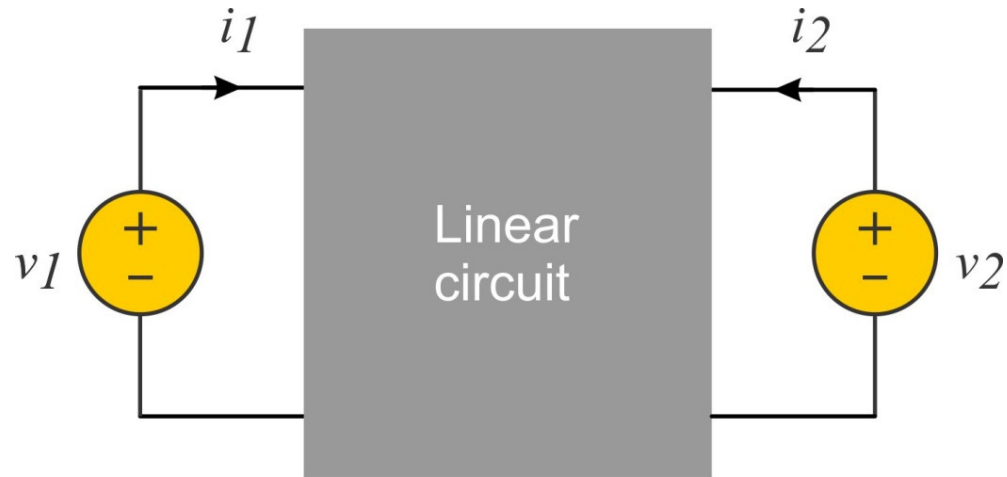

$$i_1 = i_{1a} + i_{1b}$$
$$i_2 = i_{2a} + i_{2b}$$

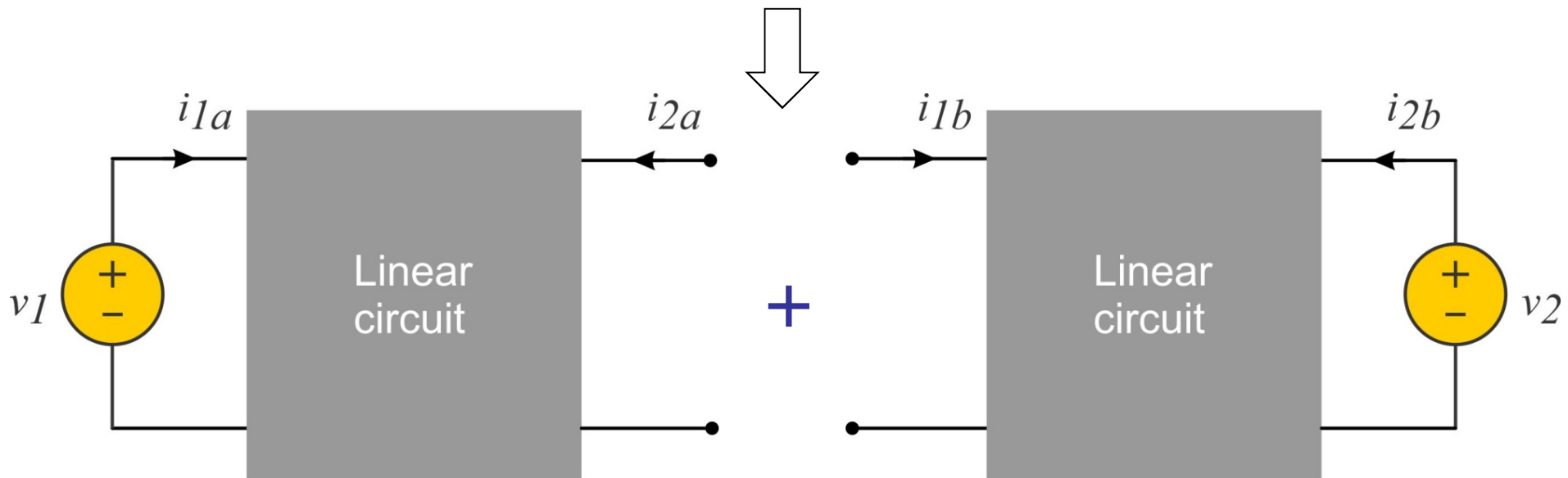

4.2 Thevenin's theorem

representation

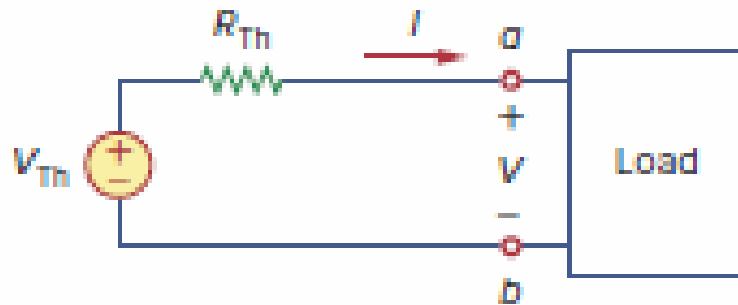
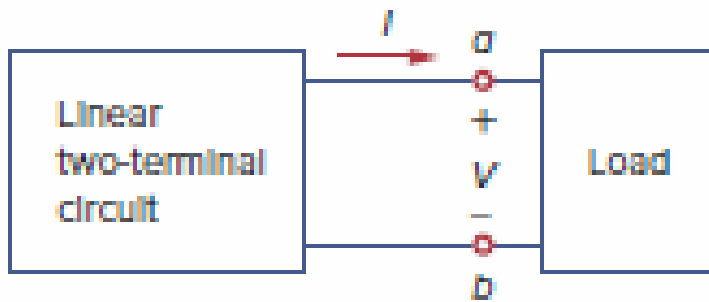

method

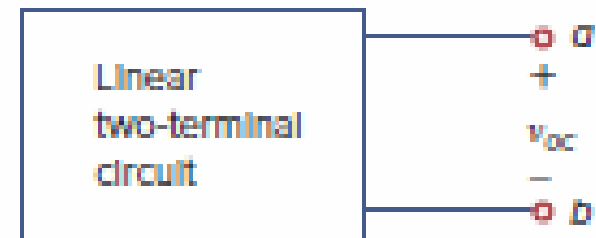

$$V_{Th} = V_{oc}$$

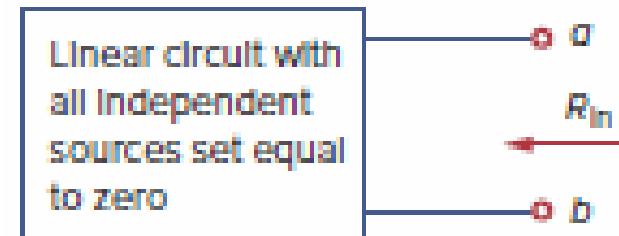

$$R_{Th} = R_{in}$$

4.3 Norton's theorem

representation

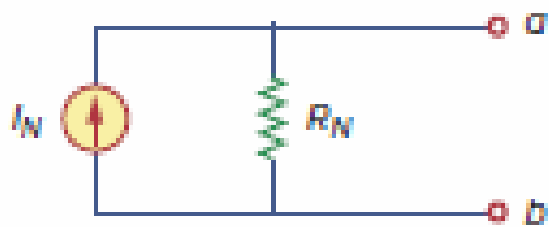
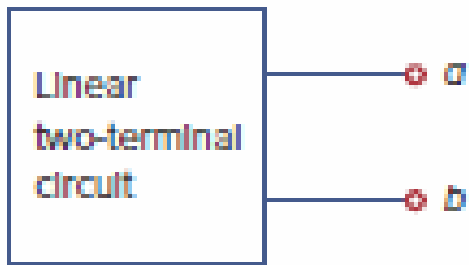

method

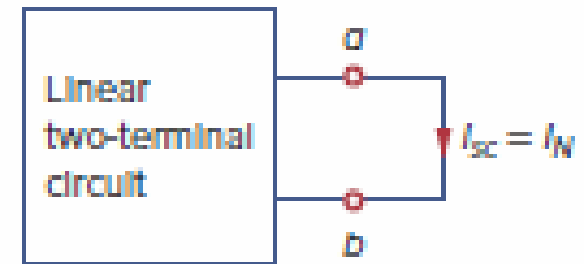

$$R_N = R_{TH}$$

4.4 Maximum Power Transfer Theorem

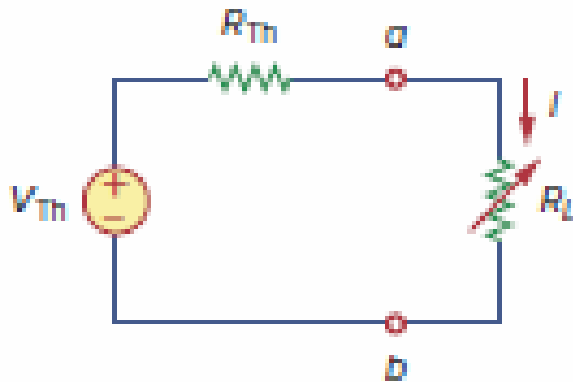

$$p = i^2 R_L = \left(\frac{V_{TH}}{R_{TH} + R_L} \right)^2 R_L$$

$$R_L = R_{TH}$$

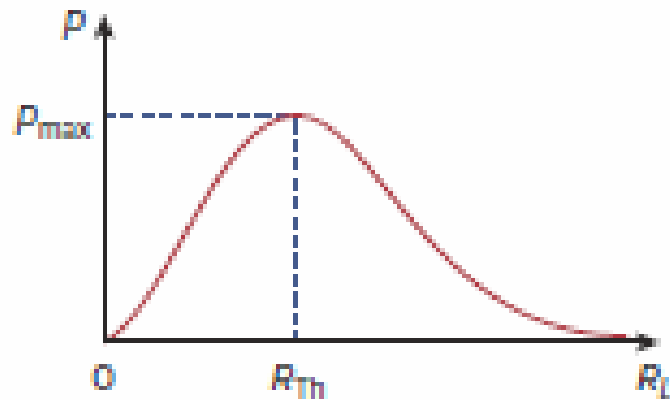

$$P_{max} = \frac{V_{TH}^2}{4R_{TH}}$$



5. DC Transient

1. *RC* transients
2. *RL* transients

5.1 RC transients

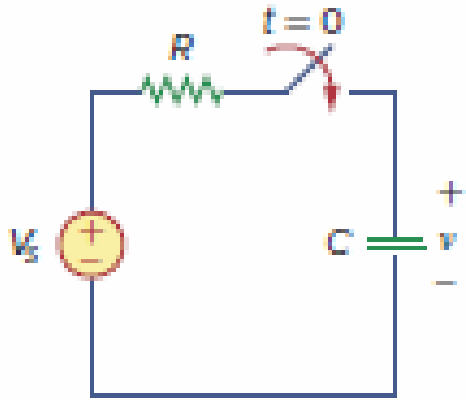

$$v(t) = \begin{cases} 0 & t < 0 \\ V_s(1 - e^{-t/\tau}) & t > 0 \end{cases}$$

$$i(t) = \frac{V_s}{R} e^{-t/\tau}$$

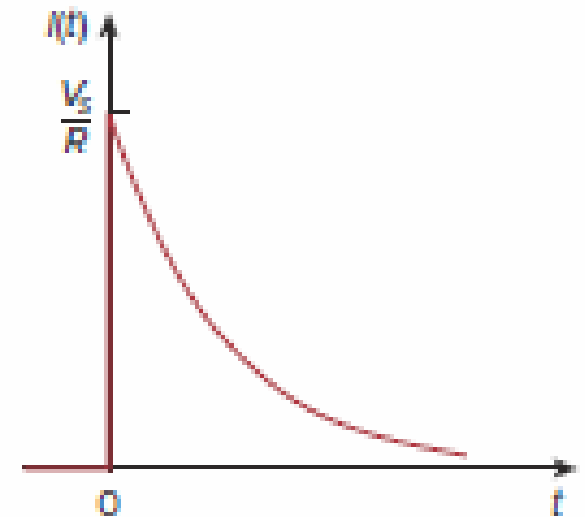
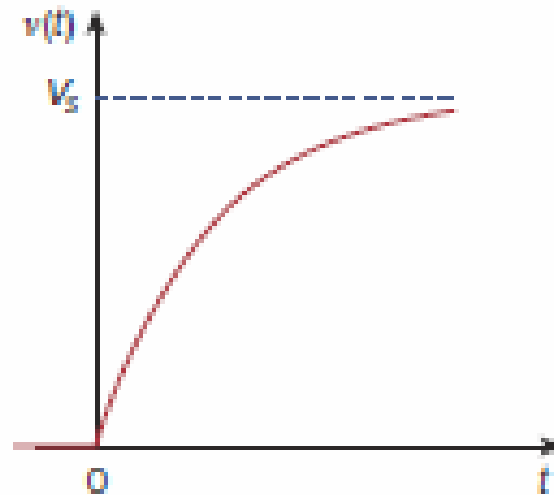

5.2 RL transients

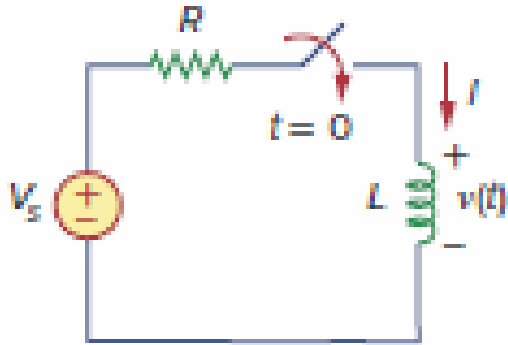

$$i(t) = \begin{cases} 0 & t < 0 \\ \frac{V_s}{R} (1 - e^{-t/\tau}) & t > 0 \end{cases}$$

$$v(t) = V_s e^{-t/\tau}$$

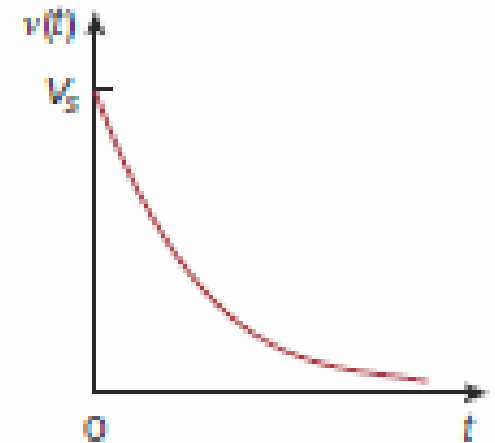
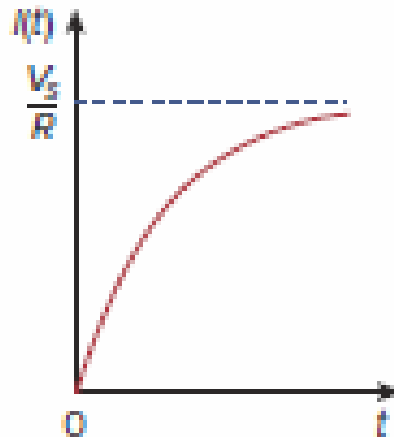

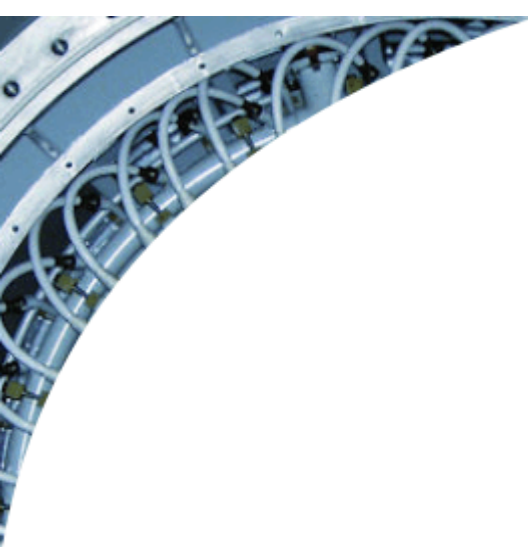

- End of Lecture: Basic EE -