

EEE 3352

Electromechanics & Electrical Machines

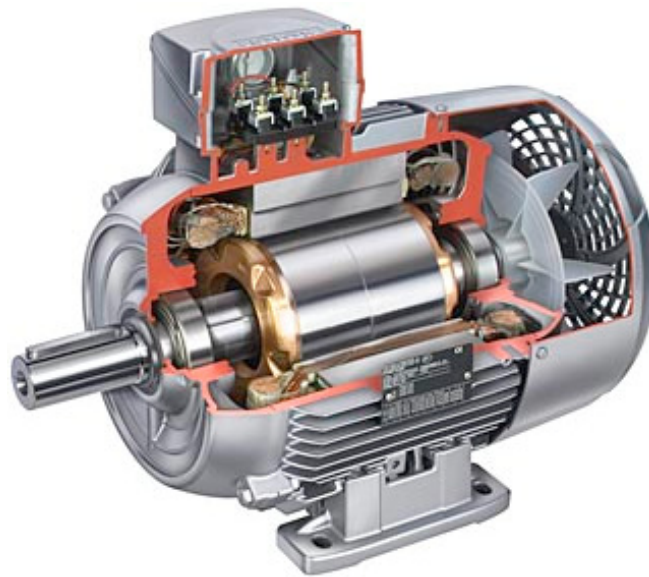

Lecture 5: Rotating machines



5. Rotating Machines

1. Introduction
2. Induced voltage
 - typical electrical machine
 - average value
 - frequency
3. Connection to output
 - slip ring
 - commutator
4. Torque



Objectives:

- at the end of the lecture, students should be able to
 - **derive** expressions of induced **voltage**, **frequency** and force/**torque** of a basic electrical machine;
 - **distinguish** the features of slip-ring and commutator output connections;
 - **calculate** induced the induced voltage, frequency and force/torque of a basic electrical machine



5.1 Introduction

- rotating machines include
 - motors
 - generators
- motors and generators are power conversion devices

Power conversion in a machine

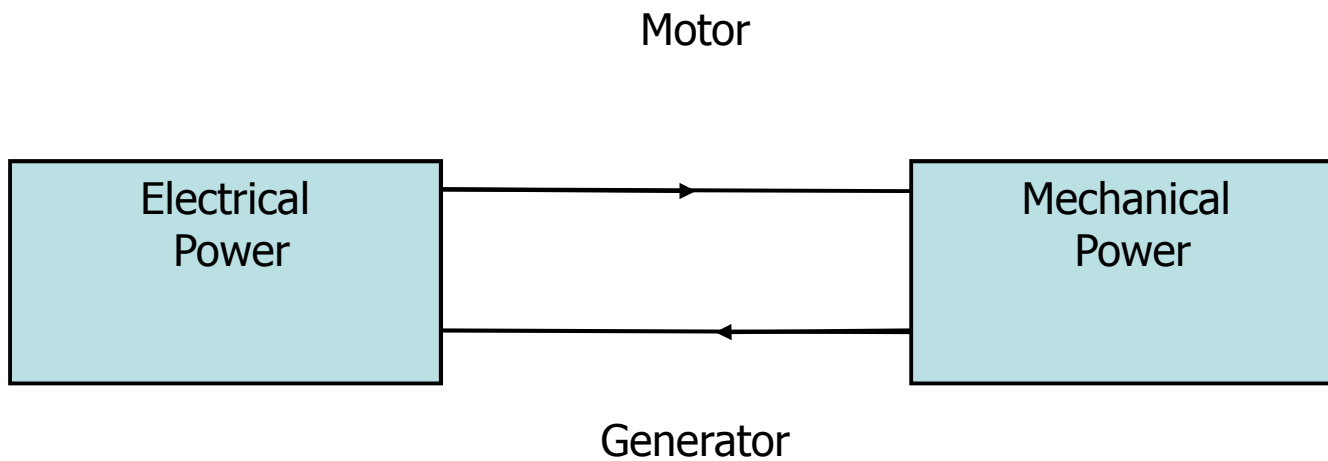

- 
- Faraday's law for one turn of coil ($N = 1$):

$$\begin{aligned} e &= \frac{d\phi}{dt} \\ &= \frac{\partial\phi}{\partial t} + \frac{\partial\phi}{\partial x} \cdot \frac{\partial x}{\partial t} \\ e &= \frac{\partial\phi}{\partial t} + u \frac{\partial\phi}{\partial x} \end{aligned}$$

$\frac{\partial\phi}{\partial t}$: changing flux with time, as in transformer, i.e. **Flux-linking**

$u \frac{\partial\phi}{\partial x}$: with motion at speed u , as in rotating machines, i.e. **Flux-cutting**

5.2 Induced voltage

- consider a conductor
 - length l
 - carrying a current i
 - moving at speed u
 - in a steady field of flux density B
- B , i , u are mutually perpendicular

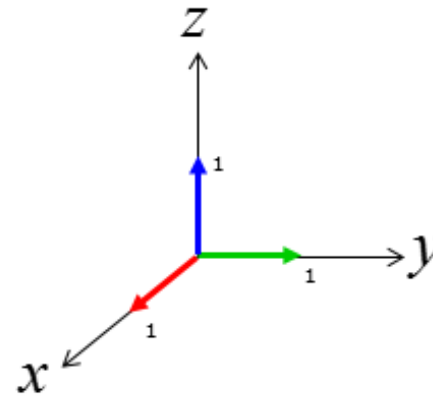
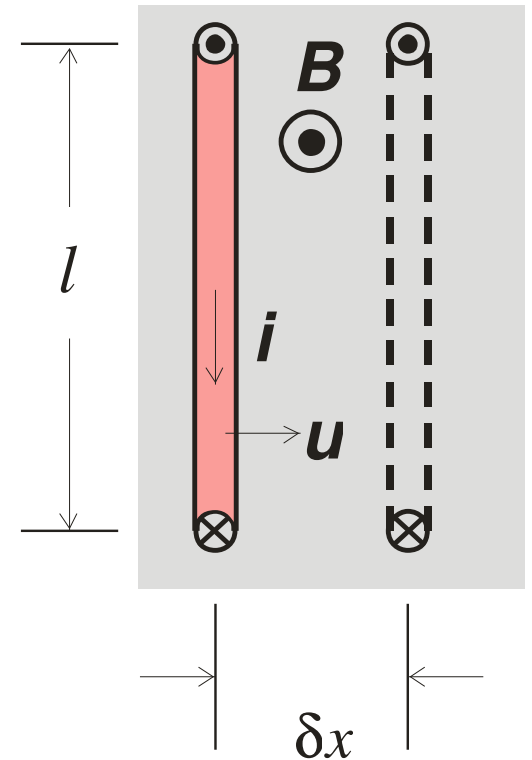



:in a time δt , the motion

$$\delta x = u \delta t$$

:flux cut is

$$\delta \phi = Bl \delta x$$

:induced voltage is

$$e = u \frac{\delta \phi}{\delta x} = Blu$$



- let there be an associated mechanical force, F_{mech}
- for steady motion (no acceleration), mechanical power is

$$F_{mech} \cdot u$$

- electrical power is

$$ei = Blui$$

- applying law of conservation of energy in unit time, ignoring losses

$$F_{mech}u = Blui$$

$$F_{mech} = Bli$$

5.2.1 Typical electrical machine

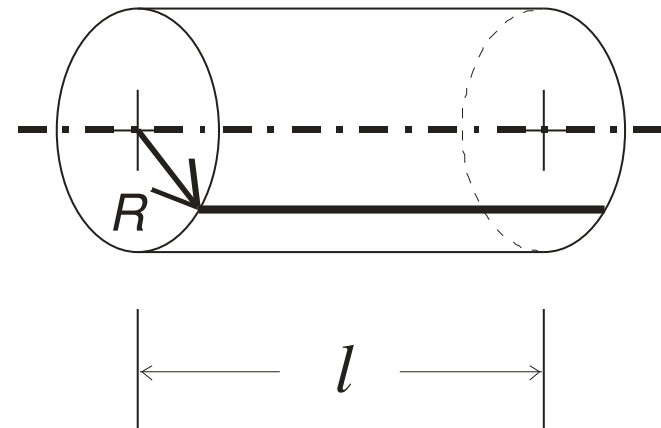
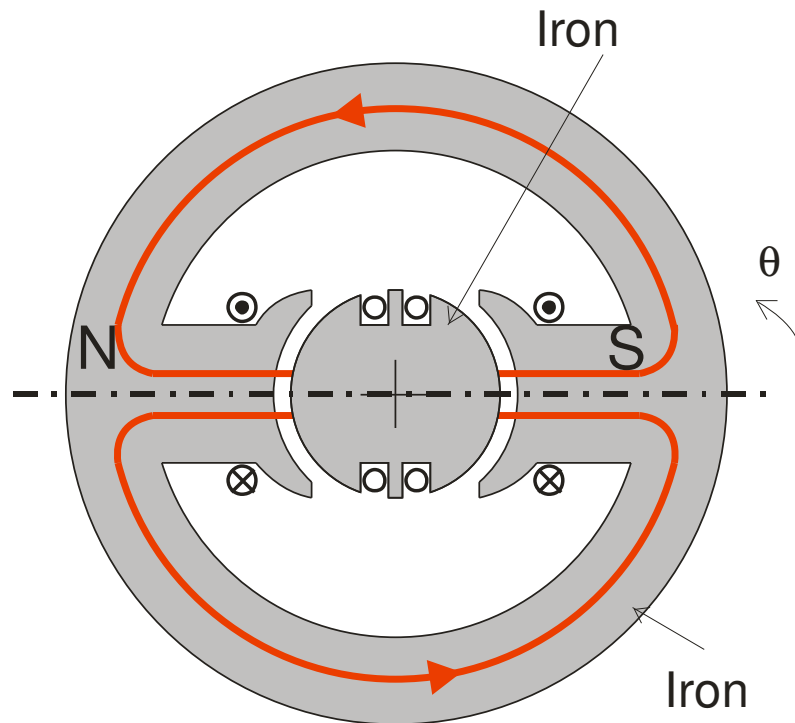



- for a conductor of length l , moving at speed u , on rotor,

$$e = Blu$$

- rotational speed is n [rev/s]

$$u = 2\pi Rn$$

$$e = (2\pi Rnl)B$$

$$e \propto B$$

variation of B for 1 rev.

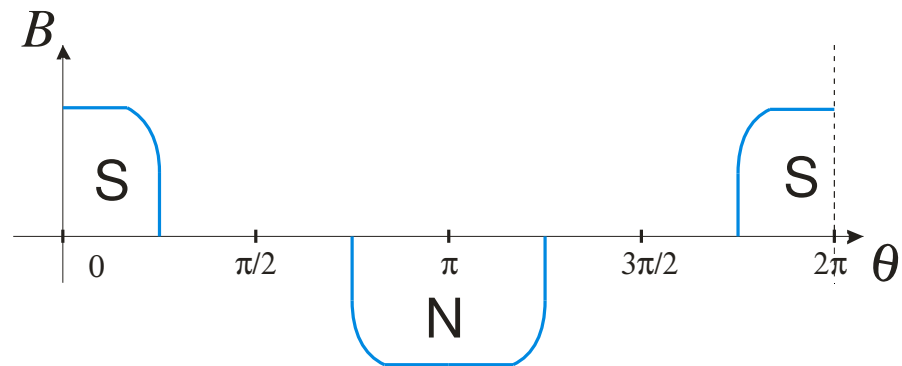

Variation of e for 1 rev.

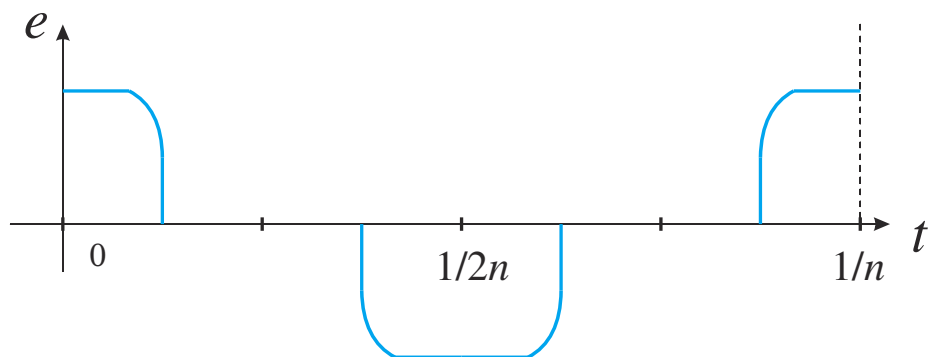

a more realistic B - θ distribution

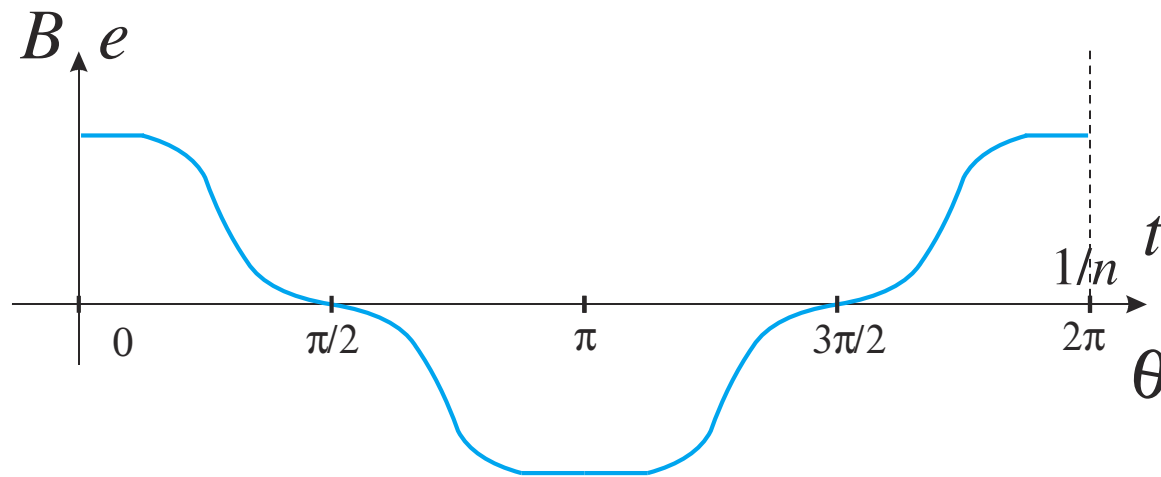

- the detailed graph of B against θ can be used with suitable change of scales for e against t

5.2.2 Average value of induced voltage

- given flux per pole, ϕ

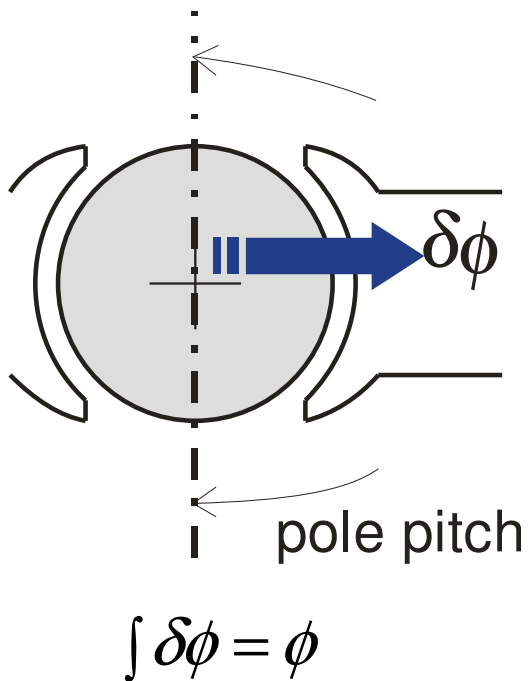

$$e|_{av} = \frac{\int_0^{\frac{T}{2}} Bludt}{\frac{T}{2}} = \frac{\int_0^{\frac{1}{2n}} Bludt}{\frac{1}{2n}} = \frac{\int d\phi}{\frac{1}{2n}} = 2n\phi$$



- for a machine with p pole pairs
- time for 1 revolution is $1/n$
- time for 1 pole pitch is

$$= \frac{1}{2p} \frac{1}{n}$$

- if flux per pole is ϕ

$$E|_{av} = \frac{\phi}{1/2np}$$

$$E|_{av} = 2np\phi$$



5.2.3 frequency of induced voltage

- consider
 - p pole pairs
 - speed of rotation n
- 1 pole gives half cycle
- 1 pole pair (2 poles) gives 1 cycle
- p pole pairs give p cycles
 - this is 1 rev, happening in time $1/n$ [s]

- 
- $\therefore p$ cycles occur in $1/n$ [s]
 - this is the frequency measured in [c/s] or Hertz [Hz]

$$f = np$$

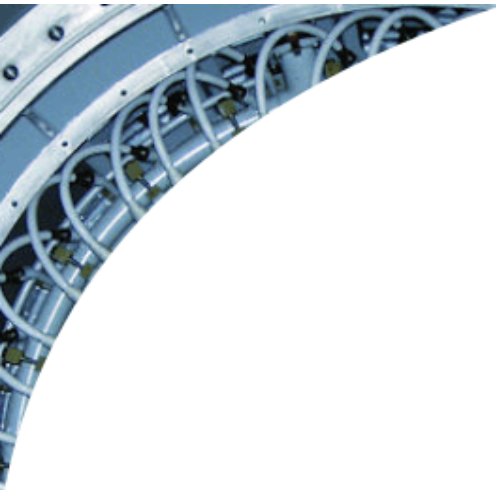

Summary

$$E_{av} = 2np\phi$$

$$f = np$$

5.3 Connection to output

Case 1: ac output (slip rings)

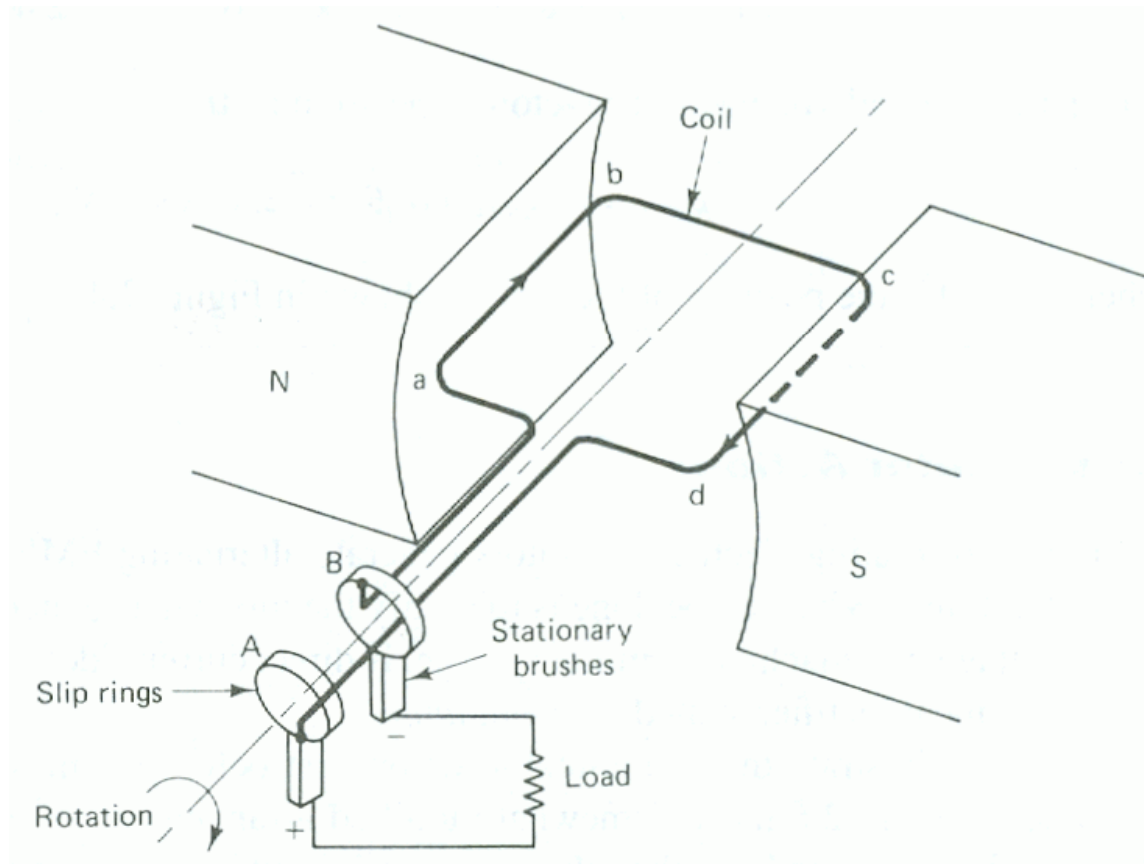

- brass rings fixed to shaft
- carbon brushes pick up

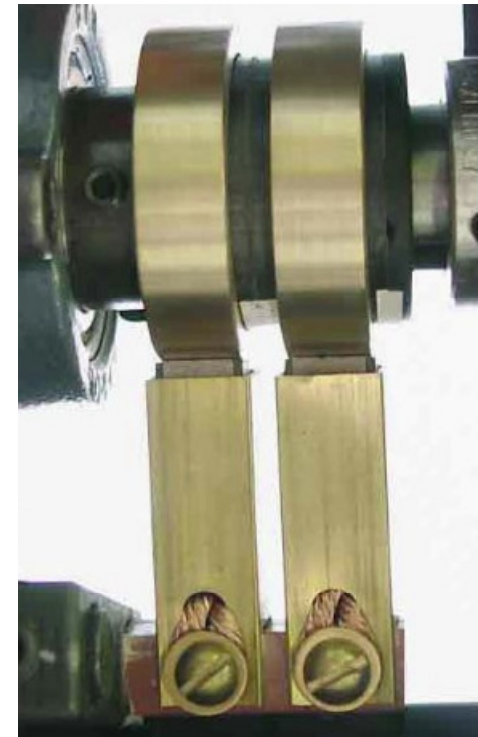



- in a real machine
 - many conductors in series Z_s for connection to slip rings and the output

- for 1 conductor

$$E_{av} = 2pn\phi$$

- for Z_s conductors connected in the same slot

$$E_{av} = 2pn\phi Z_s$$

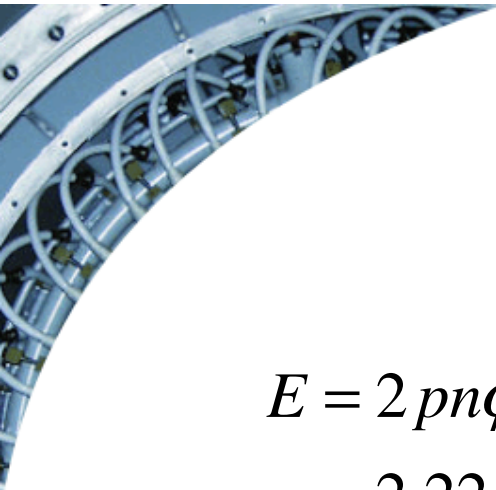

- for Z_s conductors spread around the rotor periphery:
 - same shape and magnitude of $e(t)$ for each conductor
 - $e(t)$ waveforms for conductors in slots will be shifted by slot angle
 - the waveform of total $e(t)$ will be bigger & smoother than for 1 conductor
 - with form factor for sinewave and winding factor for cylindrical rotor, output rms voltage is

$$E = 2pn\phi.Z_s.k.(1.11)$$
$$= 2.22pnZ_s\phi k$$

$$E = 2.22Z_s f \phi k$$

- k is winding factor, which includes distribution factor k_d

- this machine with slip rings gives out an ac waveform which is designed to be sinusoidal

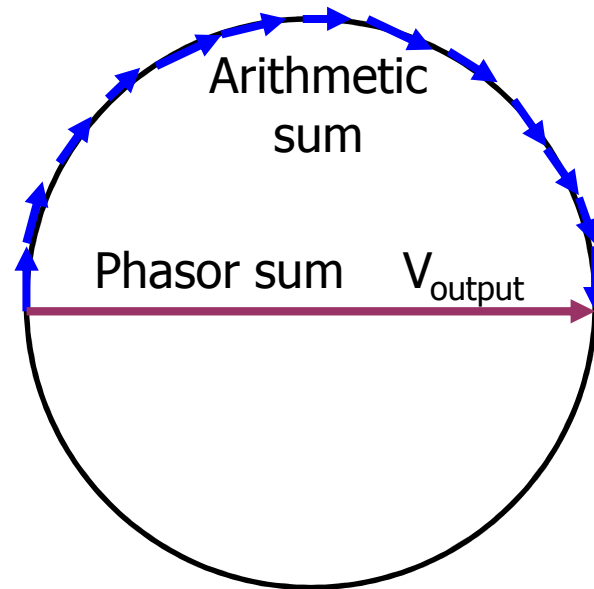

$$k_d = \frac{\textit{Phasor sum}}{\textit{Arithmetic sum}} = \frac{\textit{chord}}{\textit{arc}}$$

Case 2: dc output (commutator)

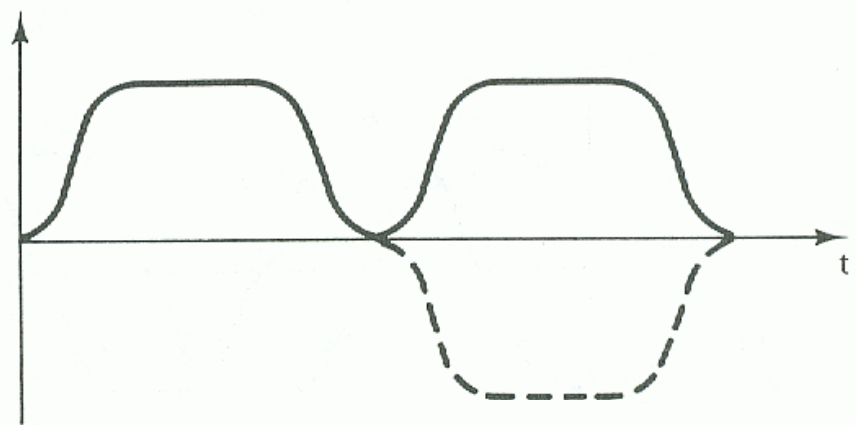
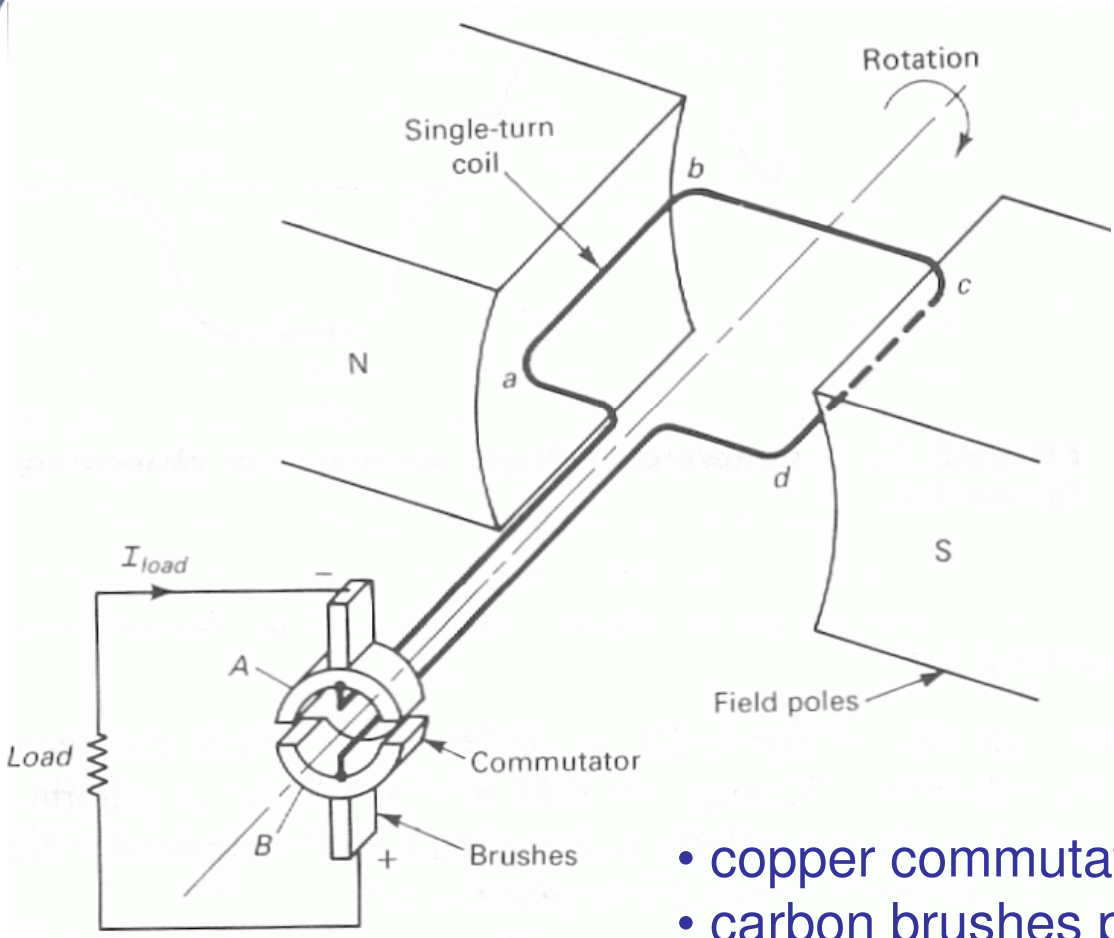

- copper commutator segments
- carbon brushes pick up

Commutator connections:

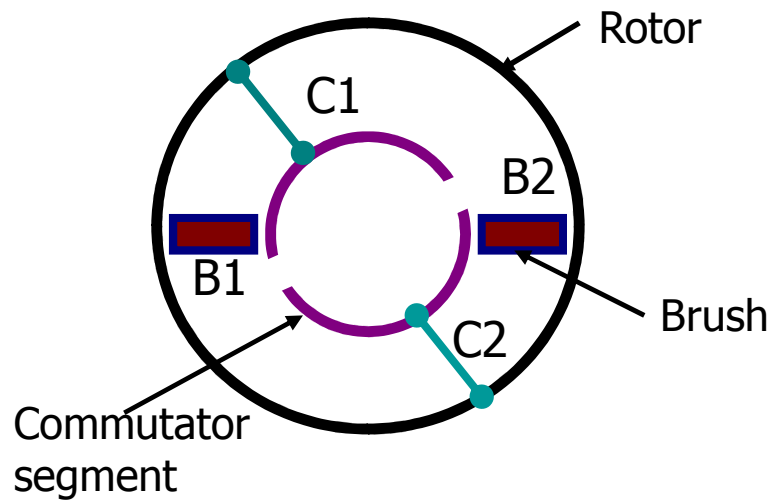

1 st half Period	2 nd half Period
B1 – C1	B1 – C2
B2 – C2	B2 – C1

B = brush terminal

C = commutator segment



- connections thru' a commutator gives an output voltage which is unidirectional

$$E_{av} = 2pn\phi$$

- if the rotor has
 - total of Z conductors
 - c paths in parallel
 - e.g. $Z = 20$, $c = 4$:

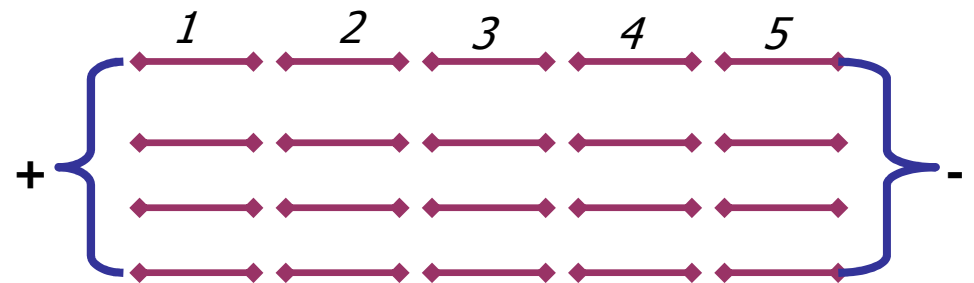

$$Z_s = \frac{20}{4}$$

- 
- In general

$$Z_s = \frac{Z}{c}$$

- average value of total dc voltage output

$$E = \frac{2pZ}{c} n\phi$$

- there are 2 types of windings:
 - **LAP** winding, for which $c = 2p$
 - **WAVE** winding, for which $c = 2$



Lap interconnection

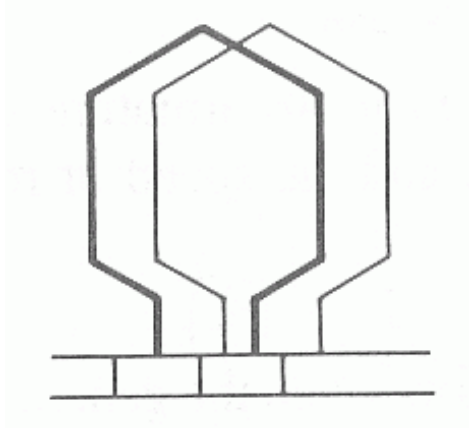

Wave interconnection

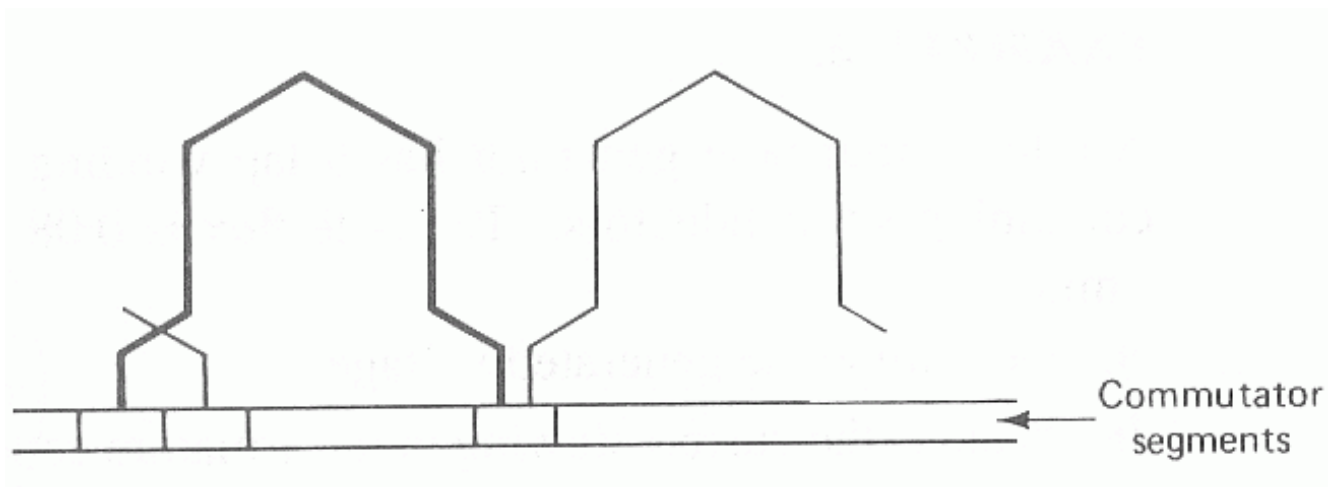



5.4 Torque

- “law of conservation of energy” , neglecting losses:

Mechanical power input = Electrical power output

$$2\pi nT = EI$$

$$T = \frac{1}{2\pi n} \left(\frac{2pZ}{c} n\phi \right) I$$

$$T = \frac{1}{2\pi} \left(\frac{2pZ}{c} \right) I\phi$$



Examples

1. For the generator shown in the caption (slip ring output), $ab = cd = 20 \text{ cm}$ and assume a uniform magnetic field $B = 0.5 \text{ T}$. For a peripheral speed of the coil sides of 12 m/s , what is the maximum voltage appearing at the slip rings?
2. A 60-kW , 4-pole generator has a lap winding placed in 48 armature slots, each slot containing 6 conductors. The pole flux is 0.08 Wb and the speed of rotation is 1040 r/min
 - a) what is the generated voltage?
 - b) what is the current flowing in the armature conductors when the generator delivers full load?

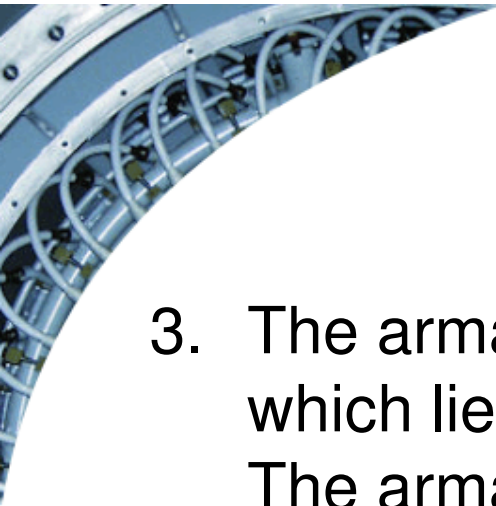

3. The armature of a dc motor has 320 conductors, only 70% of which lie directly under poles, where the flux density is 1.1 T. The armature diameter is 26 cm and its length is 18 cm. The conductor current is 12 A. Find
- the total force created by the conductors
 - the shaft torque developed

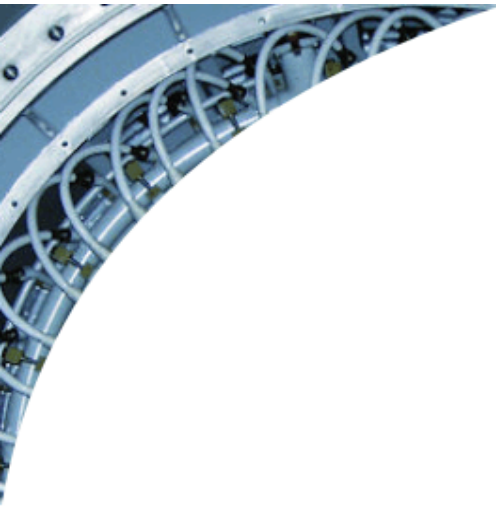

- End of Lecture 5 -