

# EEE 3352

## Electromechanics & Electrical Machines

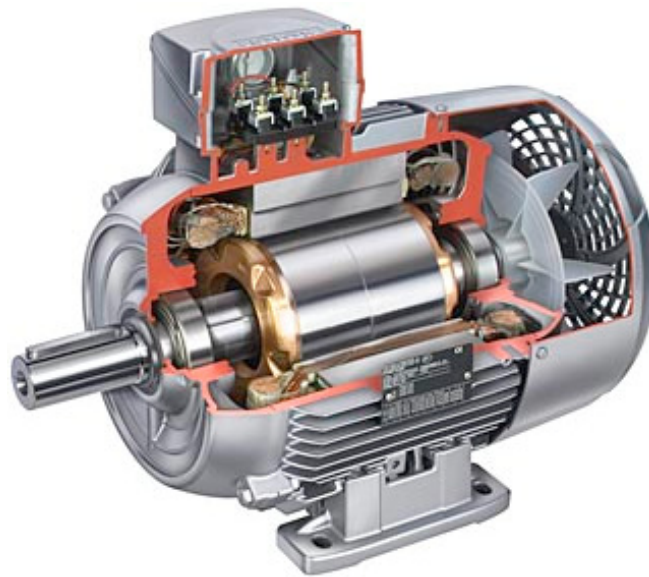

## Lecture 6: DC machines



# DC Machines

1. Introduction
2. Equivalent circuit
3. Production of flux
4. Power flow diagrams
5. DC machine configurations
6. DC generator
7. DC motor
8. Starting of DC motors



## Objectives:

- at the end of the lecture, students should be able to
  - **explain** the equivalent circuit of the dc machine
  - **develop** power balance positions for generating and motoring
  - **describe** configurations that produce different types of dc machines
  - **evaluate** the performance of the dc separate and shunt generator
  - **derive** torque-speed characteristics of dc motor: separate, shunt & series
  - **evaluate** performance of dc separate, shunt and series motor
  - **explain** the starting dc motors

# 6.1 Introduction

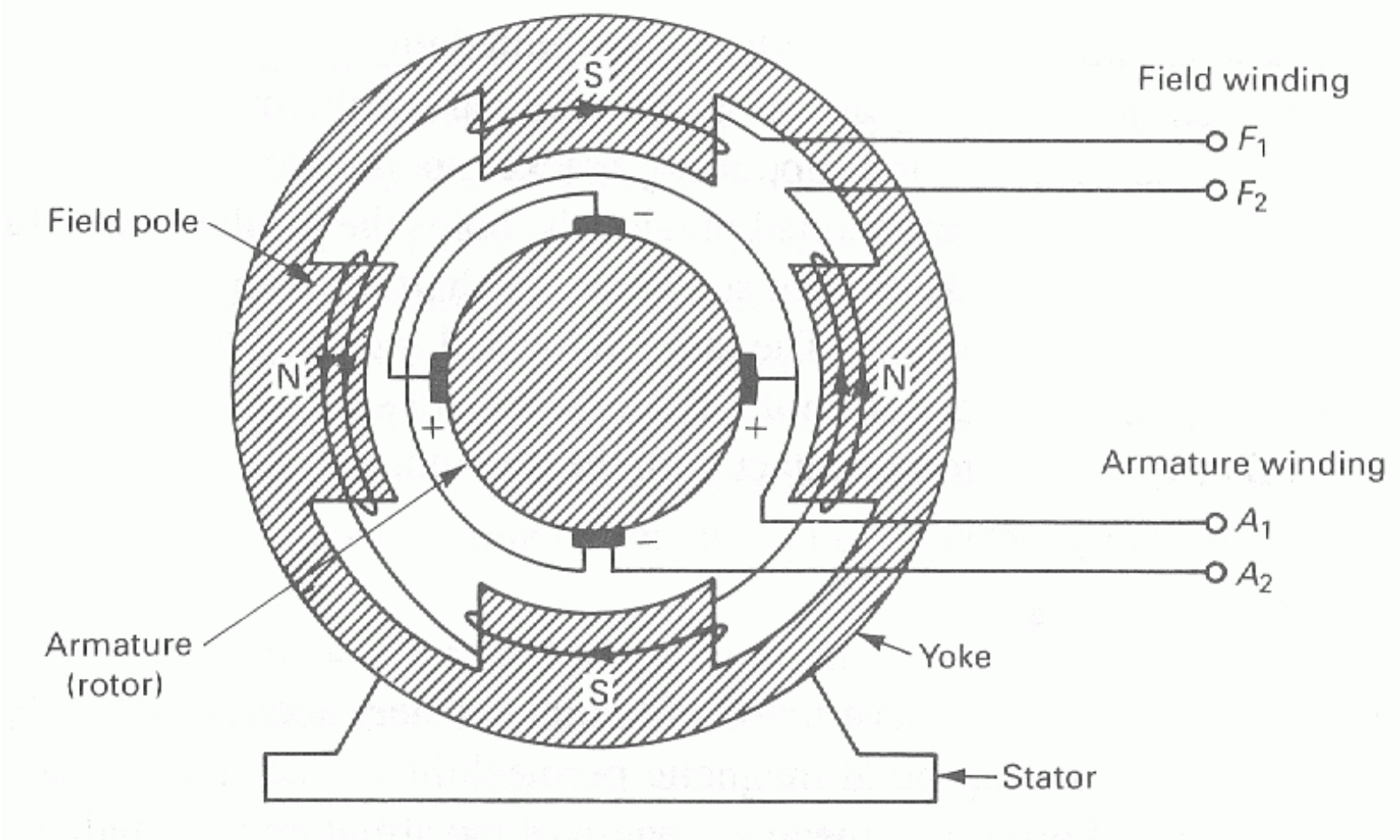

4-pole dc machine



- dc machines have  $\geq 2$  sources of magnetic excitation
- magnetic sources interact in a magnetic system
- 2 principal excitations, i.e.
  - field
  - armature
- hence dc machine are called doubly-excited machine



## Field System

- creates a magnetic field in the magnetic circuit
- 2 methods used for a creating a field
  - **electrical field winding**
    - gives **diversity** and **variety** of performance characteristics that typify dc machines
  - **permanent magnet** excitation may be employed
    - ↑ is often less costly & occupies less space
    - ↑ eliminates need for separate source of energy
    - ↓ limited power for large machines (limited to few 100 W, until recently)

## Armature System

- is the power winding of a dc machine
  - the machine's electromagnetic torque is a function of armature current
  - armature terminals are connected to the external power source/use through **commutator / brush** system

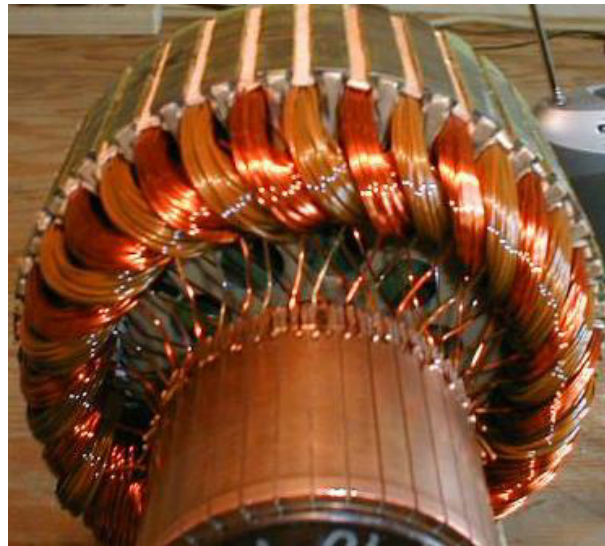



- commutator / brush system acts a mechanical switching device
  - between the external circuit and the armature winding
- external connection of the armature winding are made through the brushes resting on the commutator
  - brushes are held in stationary fixed positions
  - commutator rotates with the rotor
  - brushes are one pole-pitch apart

- 
- In **lap** winding:
    - # of brush positions equal to # of poles is required
    - half the positions are **+ve**, half are **-ve**;
      - **+ve** and **-ve** groups are paralleled through external electrical connections



- In **wave** winding
  - only two brush position are required: one **+ve** and one **-ve**
- difference between lap and wave concerns electrical performance:
  - the number of parallel electrical paths through the winding between **+ve** and **-ve** terminals of the armature
- designate **c** for number of parallel paths between armature winding terminals
  - lap:  $c = 2p$
  - wave:  $c = 2$

## 6.2 Equivalent circuit of DC machine

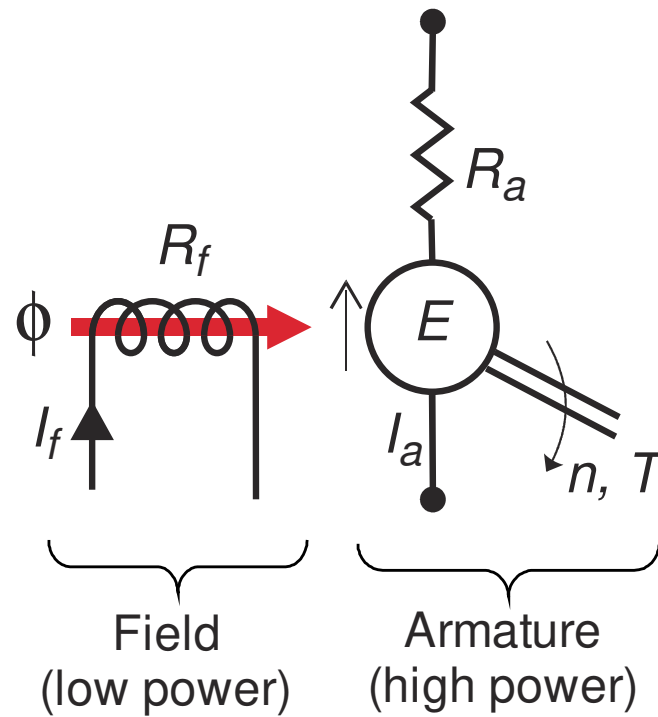



## Power Losses

### 1. Copper Loss

- armature  $\rightarrow I_a^2 R_a$

- field  $\rightarrow I_f^2 R_f = V_f I_f = \frac{V_f^2}{R_f}$

### 2. Mechanical loss

- iron loss
- friction
- windage

## 6.3 Production of flux

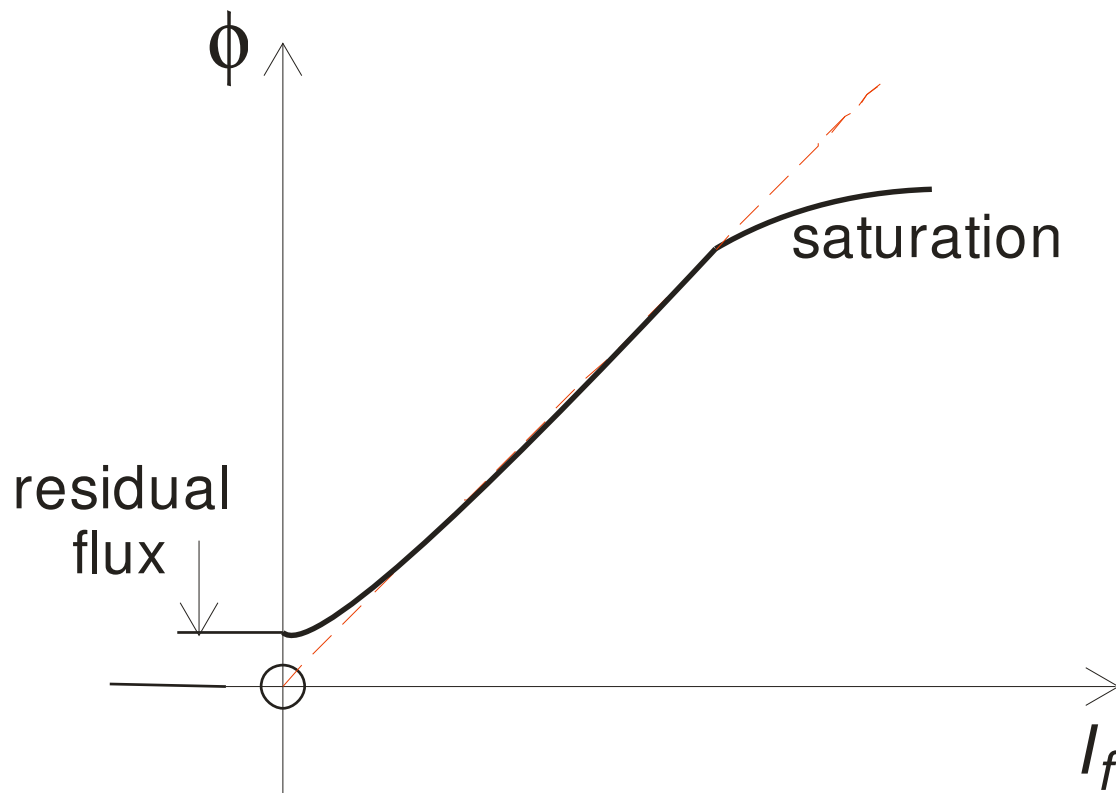

$$\phi = \frac{F}{S} = \frac{N_f I_f}{S}$$

$$\phi = k_f I_f$$

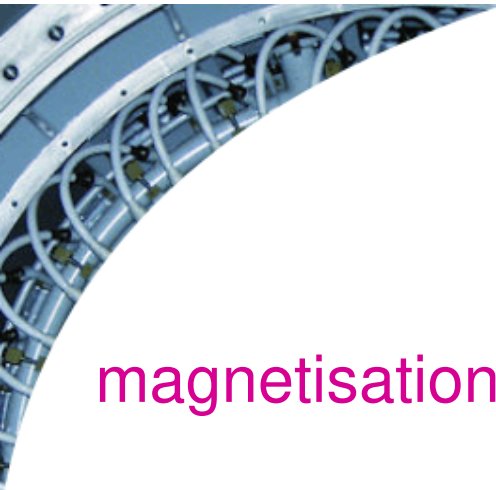

## magnetisation curve

- a linear relationship between  $\phi$  and  $I_f$ , if  $S$  is assumed constant
- deviation occurs because of saturation when  $\phi$  increases

## 6.4 Power flow diagrams

### Generator

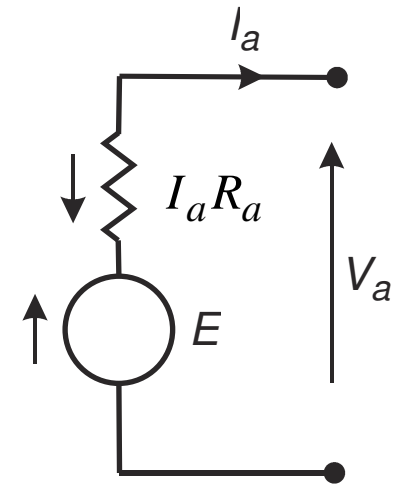
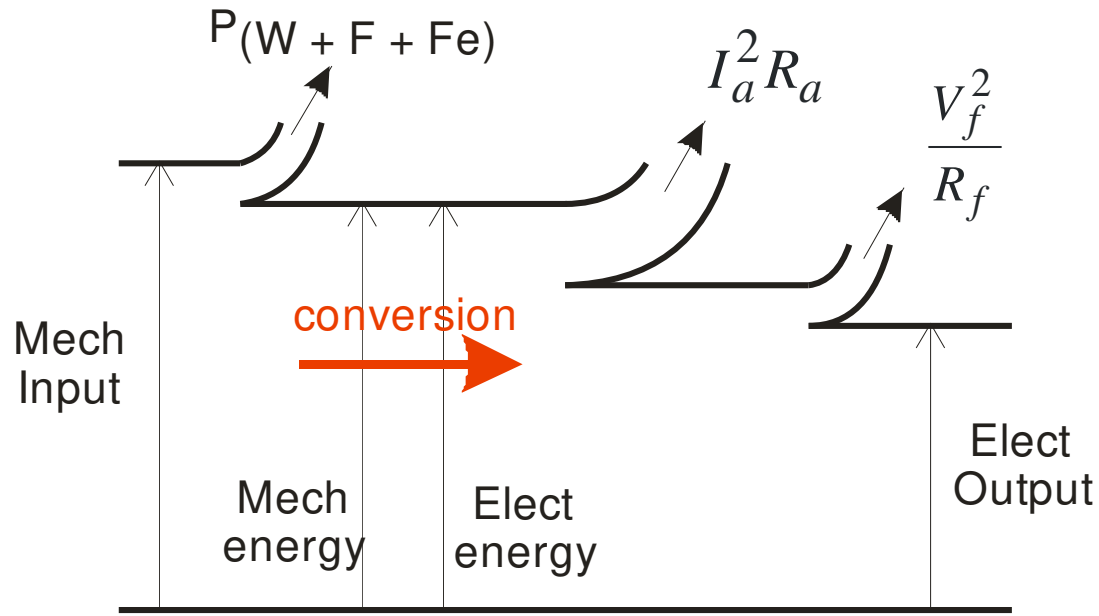

$$\eta = \frac{\text{elec. output}}{\text{mech. input}}$$

$$E = \left( \frac{2pZ}{c} \right) n\phi$$

$$V_a = E - I_a R_a$$

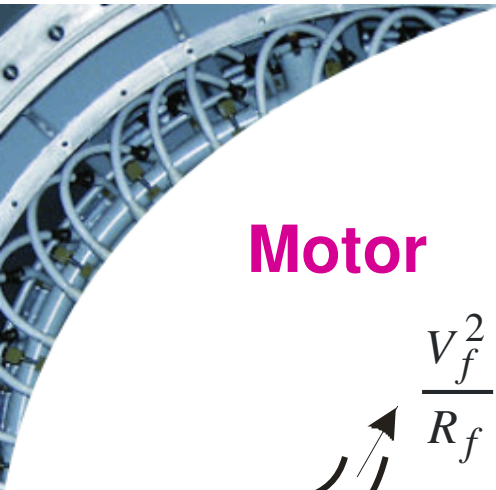

# Motor

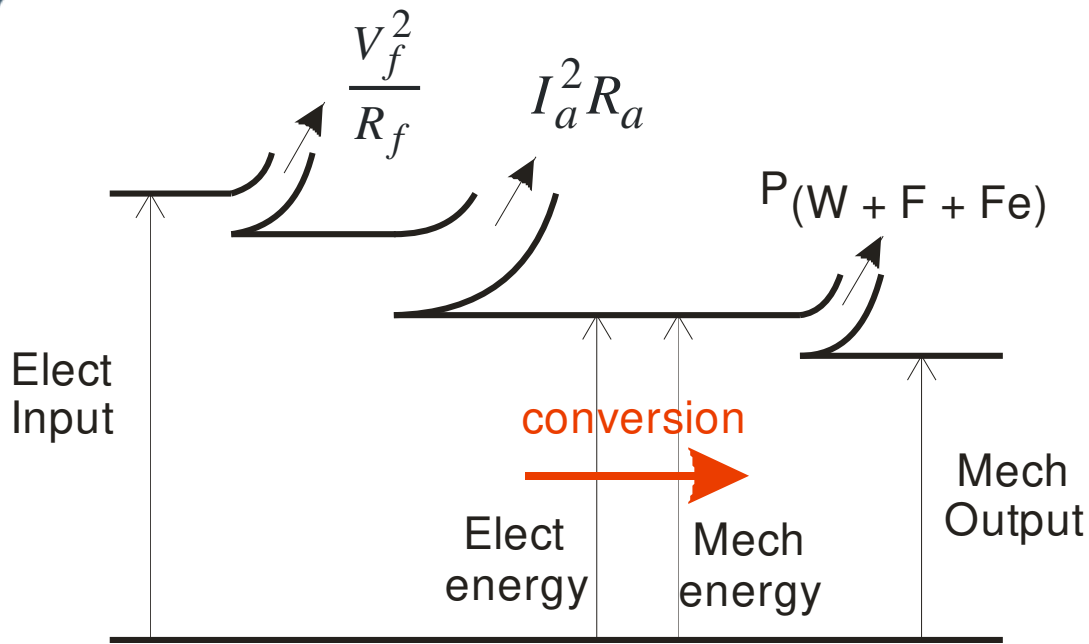

$$\eta = \frac{\text{mech. output}}{\text{elec. input}}$$

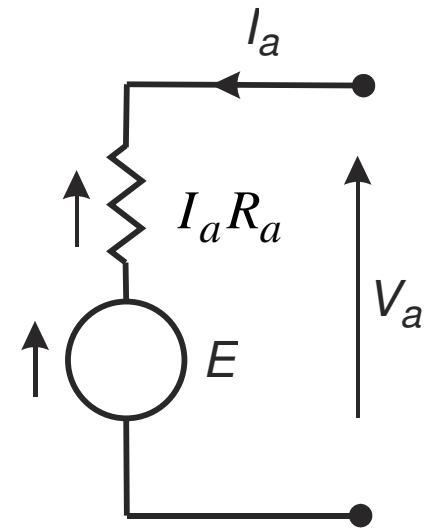

$$E = \left( \frac{2pZ}{c} \right) n\phi$$

$$V_a = E + I_a R_a$$



## 6.5 DC machine configurations

- field winding connection
  - determines the type of dc machine arrangement
  - can either be in
    - separate
    - series
    - shunt
    - compound

## dc machine windings designation

winding	BS 4999 pt3 (1977)	BS 8222 pt 6 (1964)
	+ -	+ -
armature	A1 - A2	A - AA
separate	F1 - F2	X - XX
series	D1 - D2	Y - YY
shunt	E1 - E2	Z - ZZ

- total mmf on the direct-axis is

$$\sum NI = \pm N_X I_X \pm N_Y I_Y \pm N_Z I_Z$$

Field	$\sum NI$	
separate	$\pm N_X I_X + 0 + 0$	
series	$0 \pm N_Y I_Y + 0$	
shunt	$0 + 0 \pm N_Z I_Z$	
Compound (cumulative)	$0 + N_Y I_Y + N_Z I_Z$	$0 - N_Y I_Y - N_Z I_Z$
Compound (differential)	$0 + N_Y I_Y - N_Z I_Z$	$0 - N_Y I_Y + N_Z I_Z$

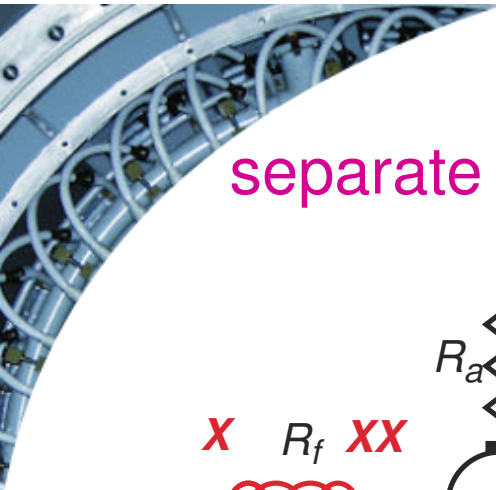

separate

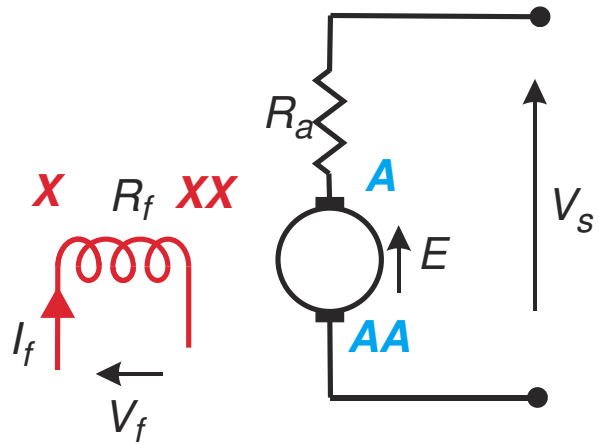

series

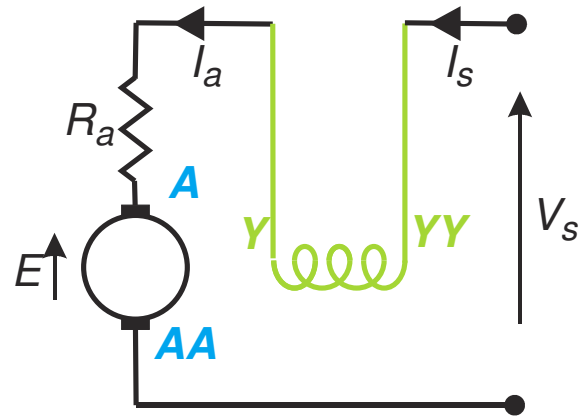

shunt

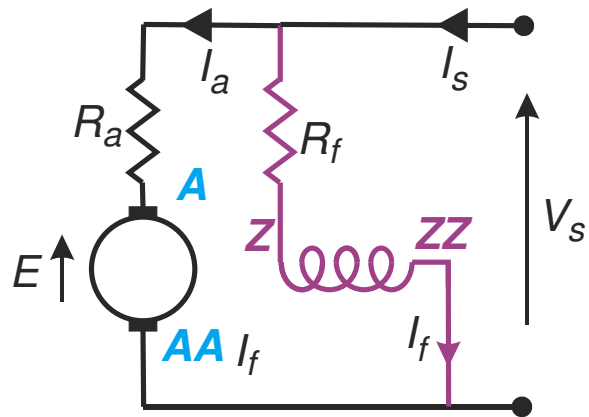

compound

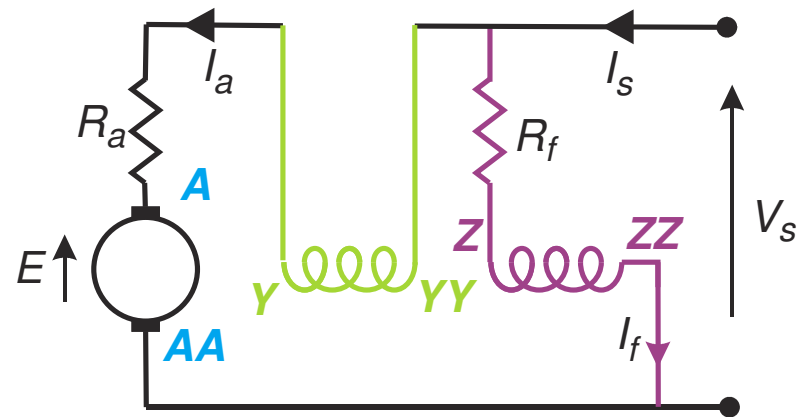



## 6.6 DC Generator

- dc supplies are commonly derived from ac supplies by rectification
- dc generators are built with outputs of a few **W** to several **MW**
- dc generators applications in
  - 1) electrochemical plants for electro deposition and metal refining [✓] + [X]
  - 2) battery charging for standby or emergency supply [X]
  - 3) diesel-electric locomotives [X]
  - 4) synchronous machine excitation [✓]
  - 5) automatic control systems [✓] + [X]

## 6.6.1 Saturation curve

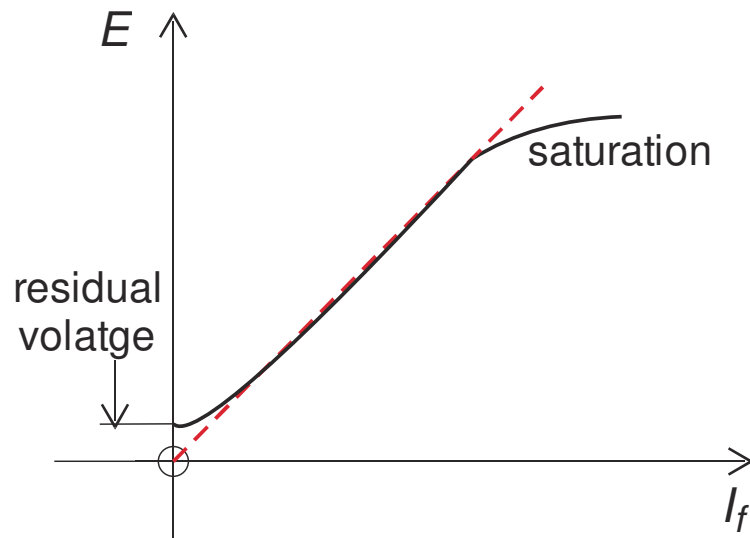

$$E = \left( \frac{2pZ}{c} \right) n\phi$$

$$E \propto \phi \quad (n \text{ const.})$$

$$E \propto n \quad (I_f \text{ const.})$$

- the no-load saturation curve of a dc machine
- curve of emf  $E$  versus field current  $I_f$  for the machine running at rated speed on no-load
- a.k.a. **open-circuit characteristic** or **magnetisation curve**

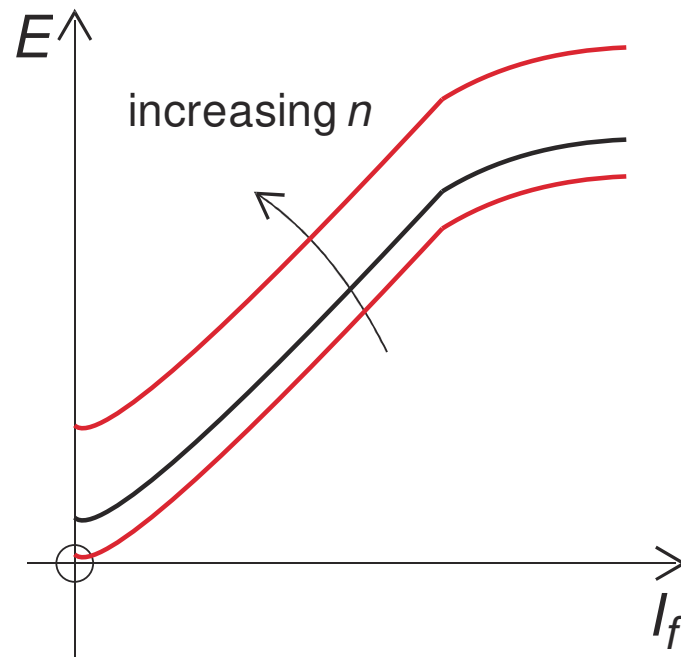
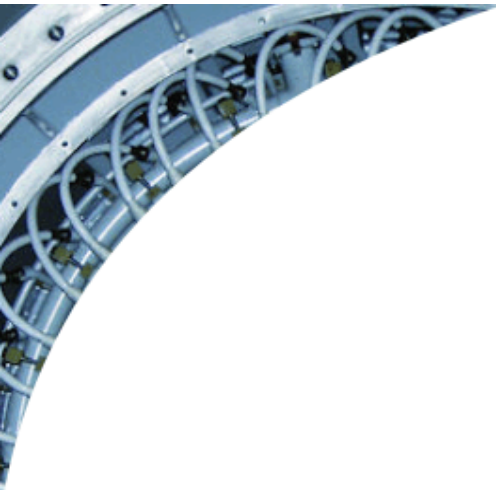

## 6.6.2 DC generator equivalent circuit

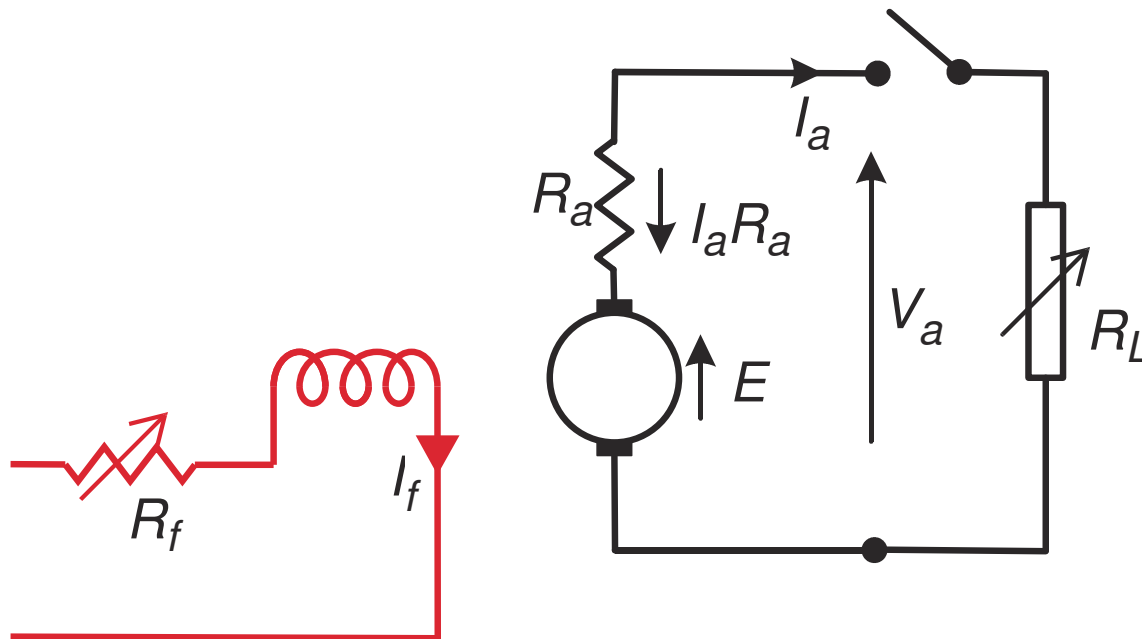

$$E = \left( \frac{2pZ}{c} \right) n\phi$$

$$V_a = E - I_a R_a$$

## 6.6.3 Separate excitation

- $I_f$  is from a separate source (external)

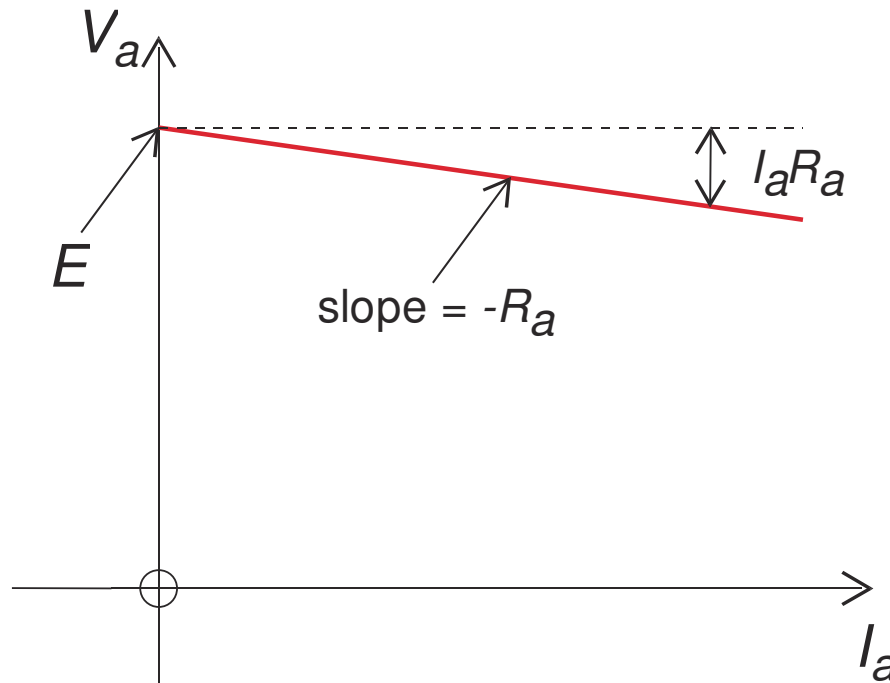

$$V_a = E - I_a R_a$$

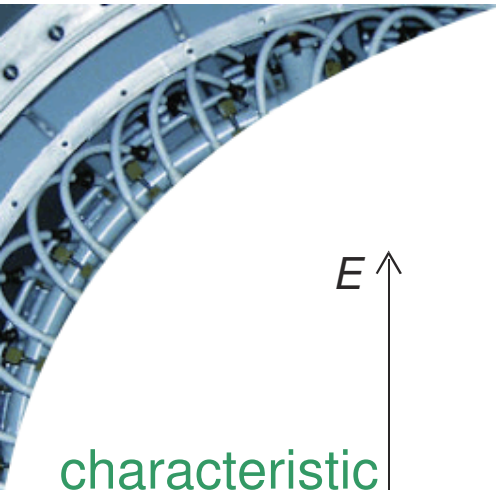

Vary  $n$

characteristic curve

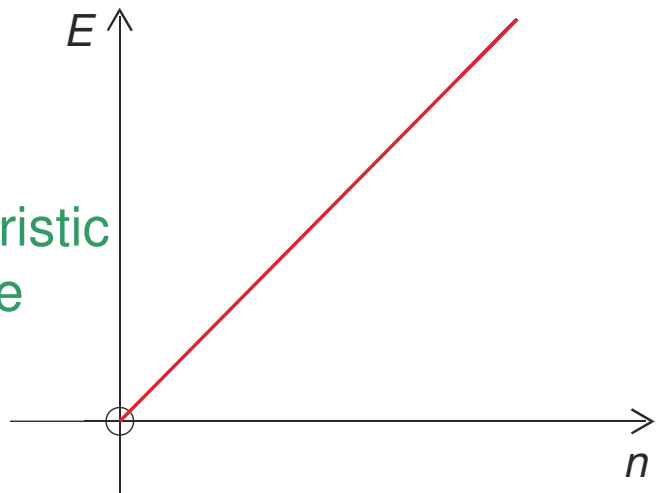

Vary  $I_f$

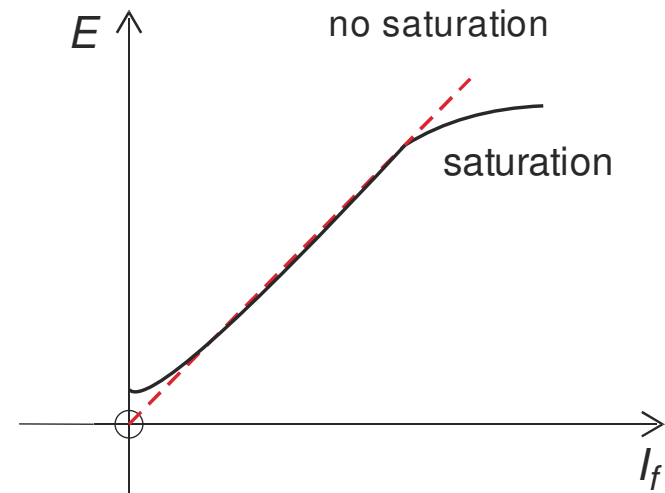

with load:  
family of curves

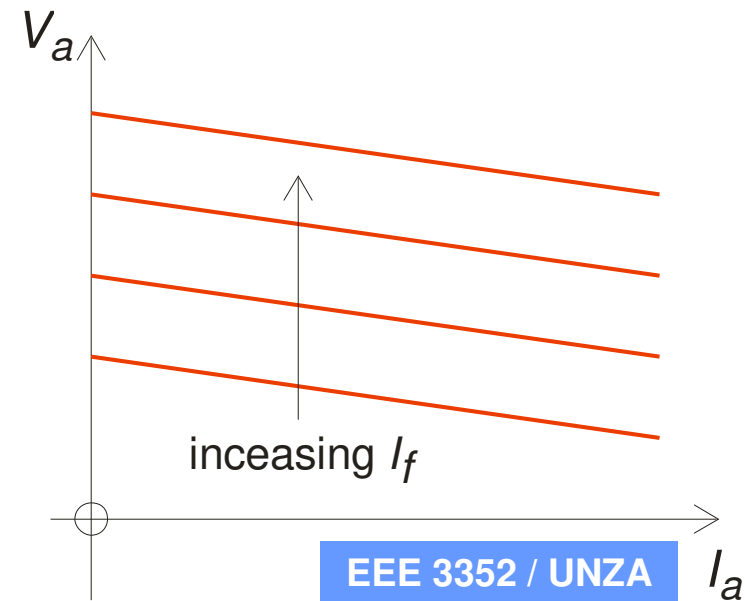
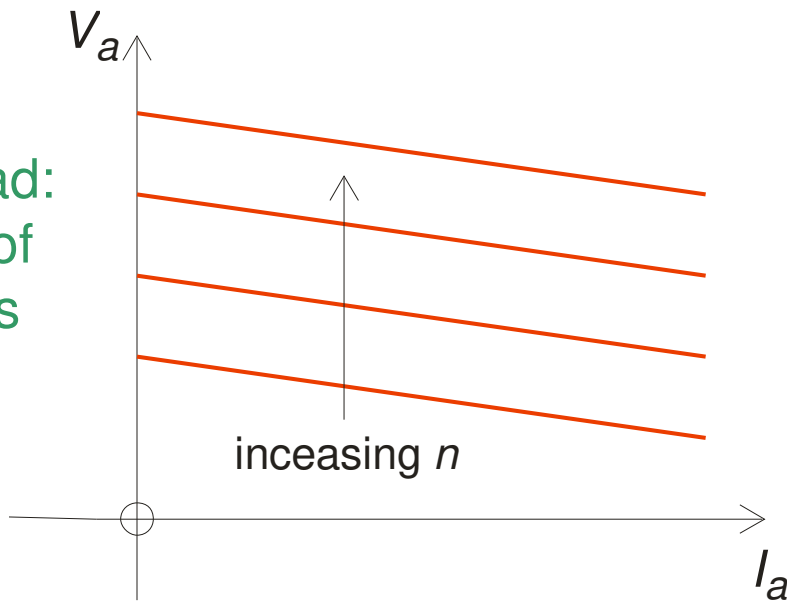

## 6.6.4 Shunt excitation

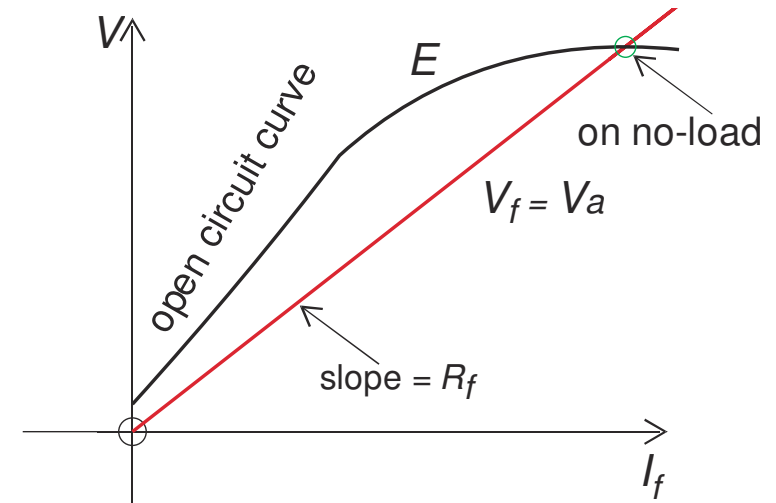
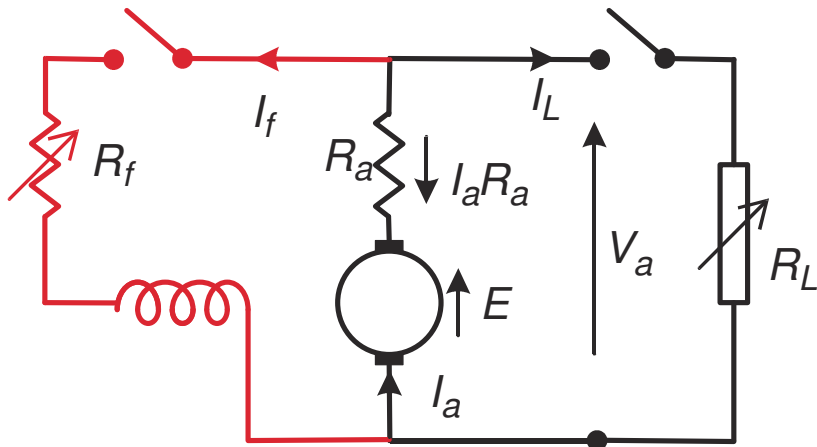

1) close field switch, then

$$V_f = V_a$$

1) on load with load switch closed

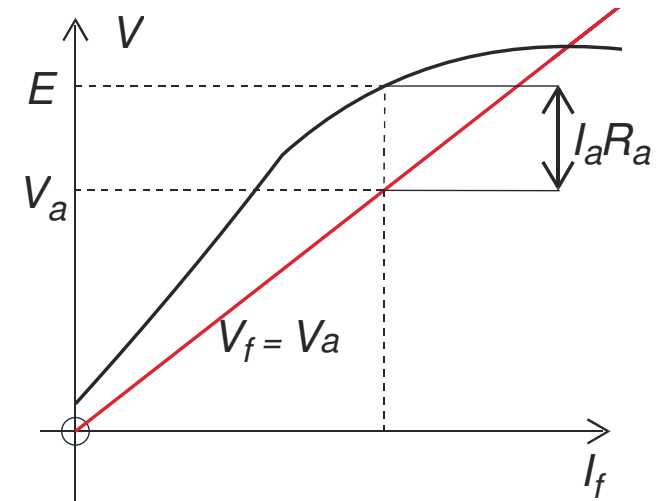



- on load with load switch closed,  $I_L$  flows and  $I_a$  is significant
- when  $I_a$  is increased,  $V_a$  reduces (due to  $I_a R_a$  drop), as in the case of separate excitation
- $V_f$  reduces,  $I_f$  reduces,  $\phi$  reduces (unlike in separate excitation)
- $\therefore E$  reduces
- $V_a$  reduces even further

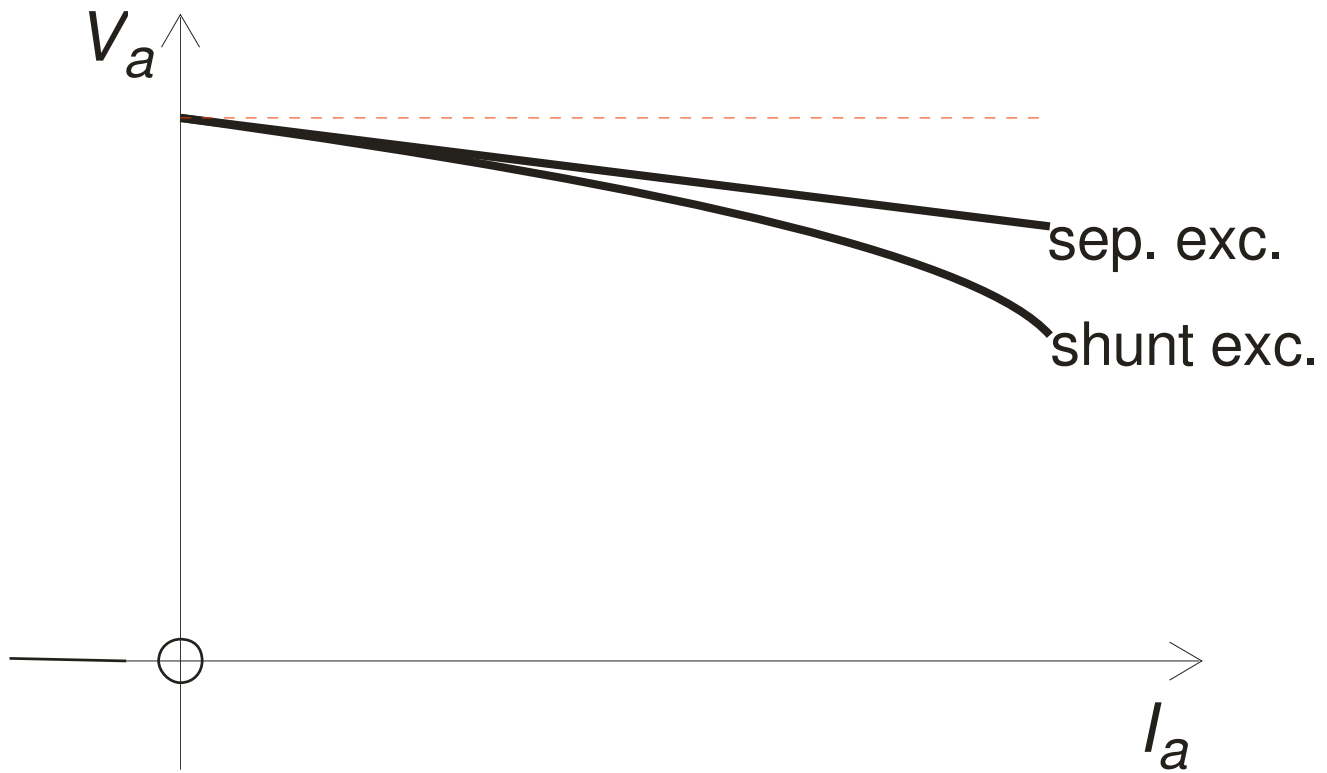

## 6.6.5 Why shunt generator may fail to self-excite

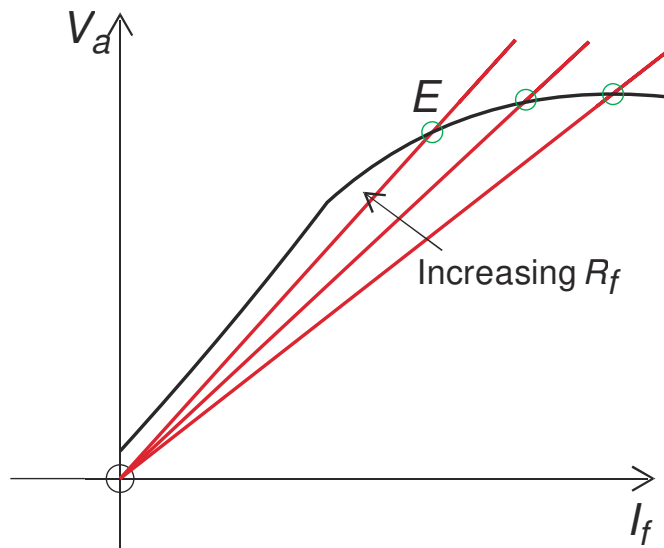

$R_f$  is too high

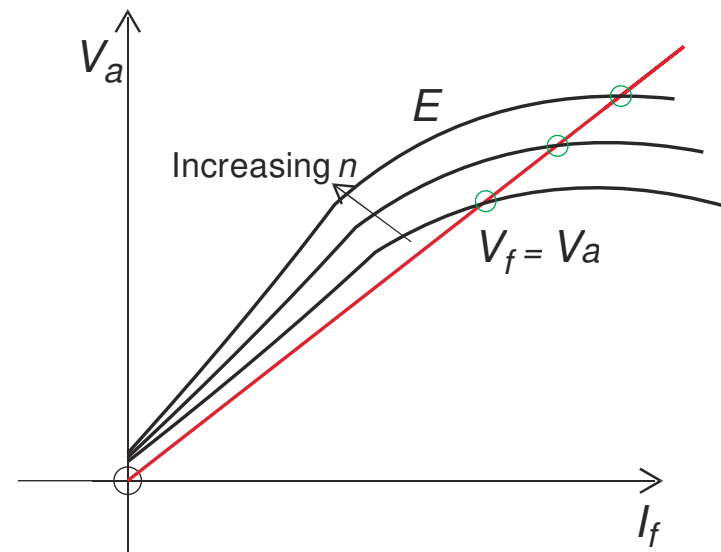

$n$  is too low



## 6.7 DC Motors

- most common industrial workhorse is ac cage induction motor
- dc motor is more complex and more costly
- dc motor has advantage of
  - a wide variety of torque-speed [ $T$ - $n$ ] characteristics
  - economical speed control
- relationship between  $n$  and  $T$  corresponds to relationship between  $V$  and  $I_a$  for a generator
- $n$  at which motor runs depends on the balancing point of the electromagnetic torque  $T_e$  and the mechanical load torque  $T_m$

## 6.7.1 DC shunt motor

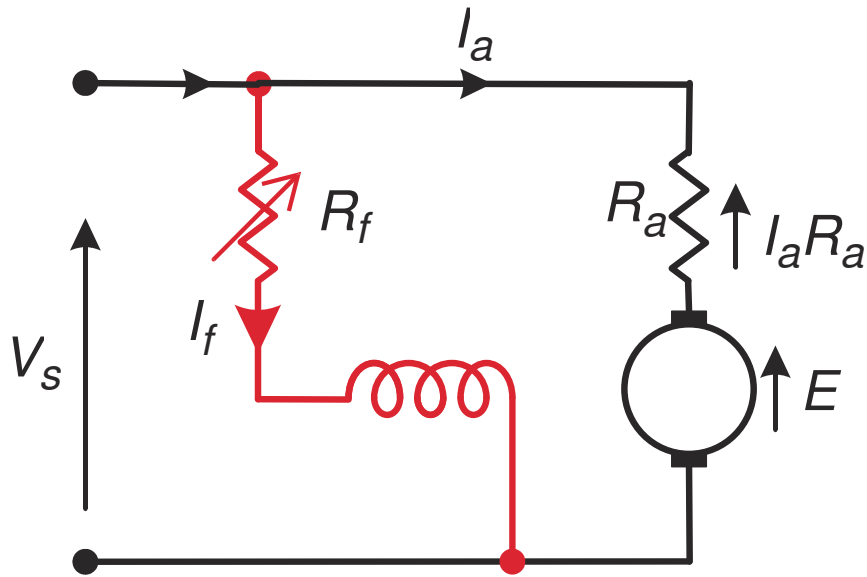

$$E = \left( \frac{2pZ}{c} \right) n\phi$$

$$T = \frac{1}{2\pi} \left( \frac{2pZ}{c} \right) \phi I_a$$

---

$$E = V_s - I_a R_a$$

- at constant  $I_f$  ( $\therefore$  constant  $\phi$ , since  $V_s = \text{const.}$ )

$$E \propto n$$

$$T \propto I_a$$

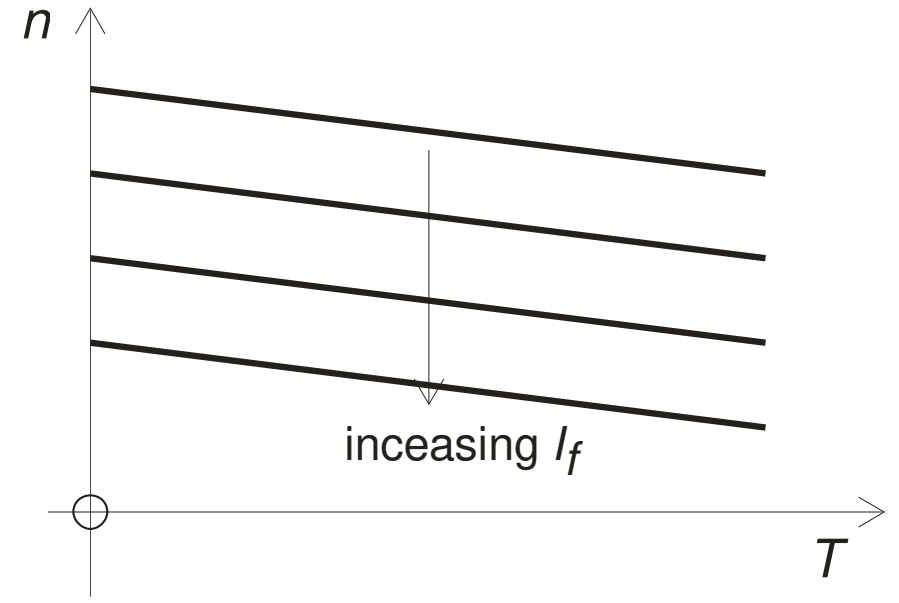
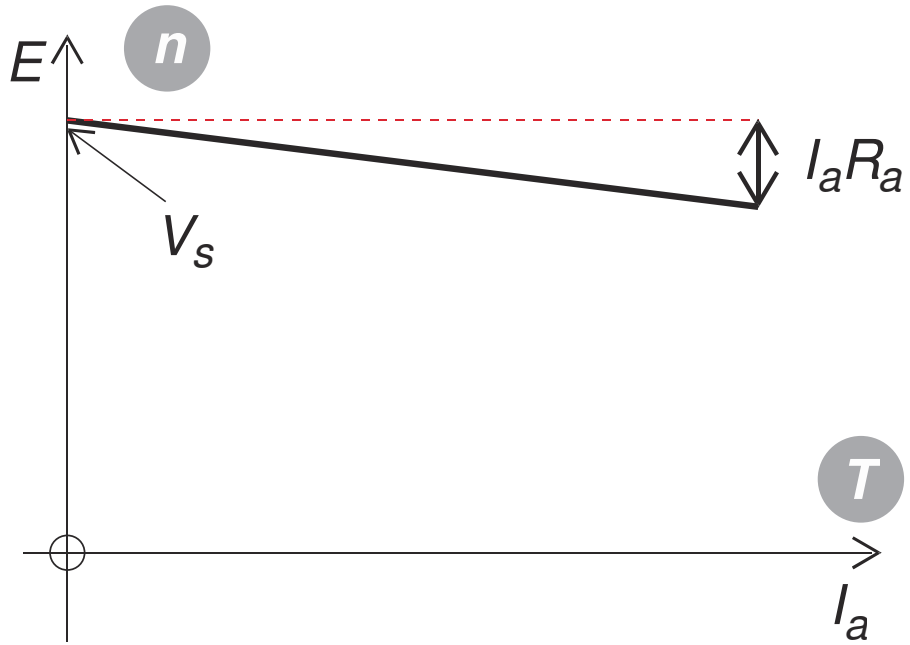
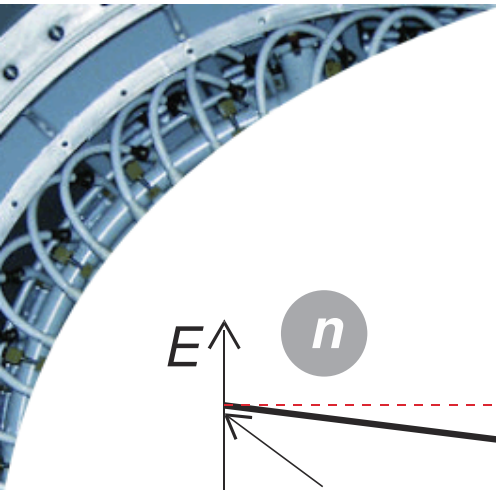

- characteristic behaviour is the same for separately-excited since

$$V_s = V_a = \text{constant}$$

## 6.7.2 DC series motor

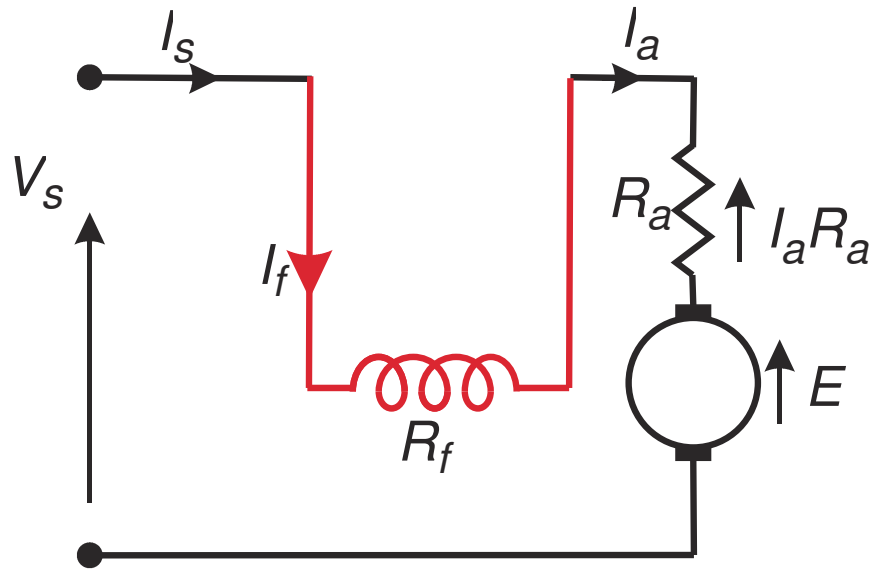

$$I_s = I_a = I_f = I$$

- 2 assumptions

- 1) neglect " $IR$ " drops

- 2) neglect saturation, so  $\phi \propto I$

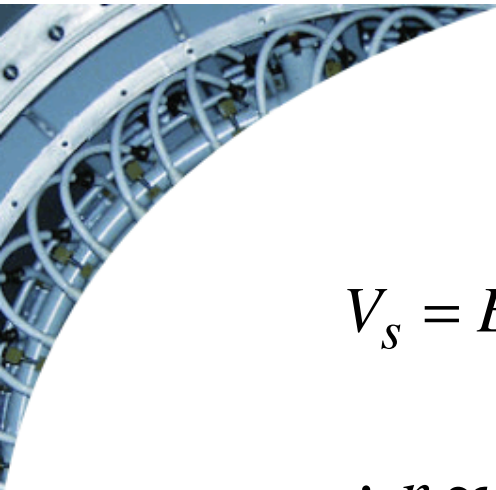

$$V_s = E = \left( \frac{2pZ}{c} \right) n \phi$$

$$\therefore n \propto \frac{1}{\phi} \propto \frac{1}{I}$$

$$T = \frac{1}{2\pi} \left( \frac{2pZ}{c} \right) \phi I_a$$

$$T \propto I^2$$

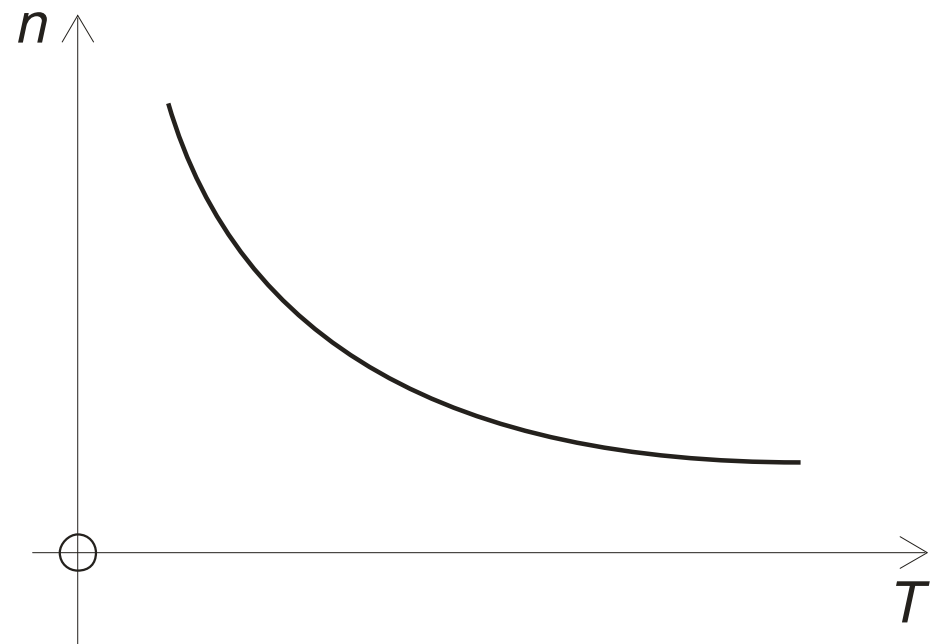
$$T \propto \frac{1}{n^2}$$



## Using a current diverter

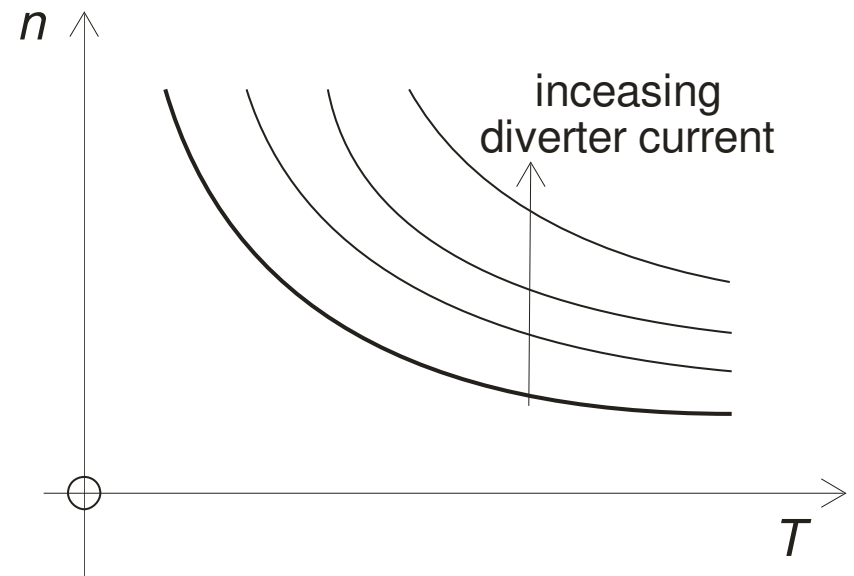
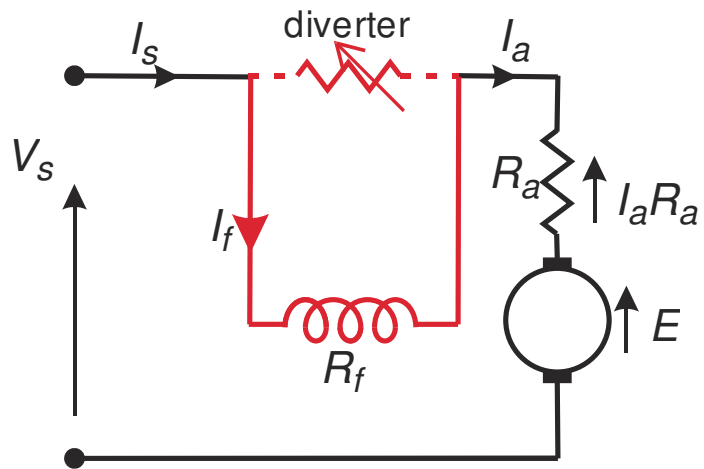

- gives a family of  $T$ - $n$  curves

## 6.8 Starting DC motors

$$V_s = E + I_a R_a$$

- for  $V_s = 220$  V,  $R_a = 1$   $\Omega$  (e.g.)

	$I_a$	$V_s$	=	$E$	+	$I_a R_a$
Full-load	10 A	220	=	210	+	10 x 1
No-load	1 A	220	=	219	+	1 x 1
Starting	?	220	=	0	+	? x 1

- for an assumed no-load  $I_a = 1$  A and full-load  $I_a = 10$  A,
  - starting current is 220 A!
- this is unacceptable

- to limit the starting current
  - include a temporary resistor in the armature
- this starting resistance is gradually reduced to zero as the machine speeds

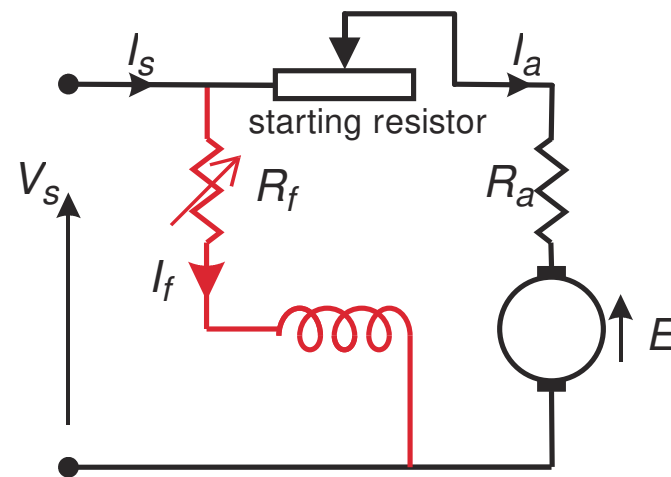

# A practical manual starter

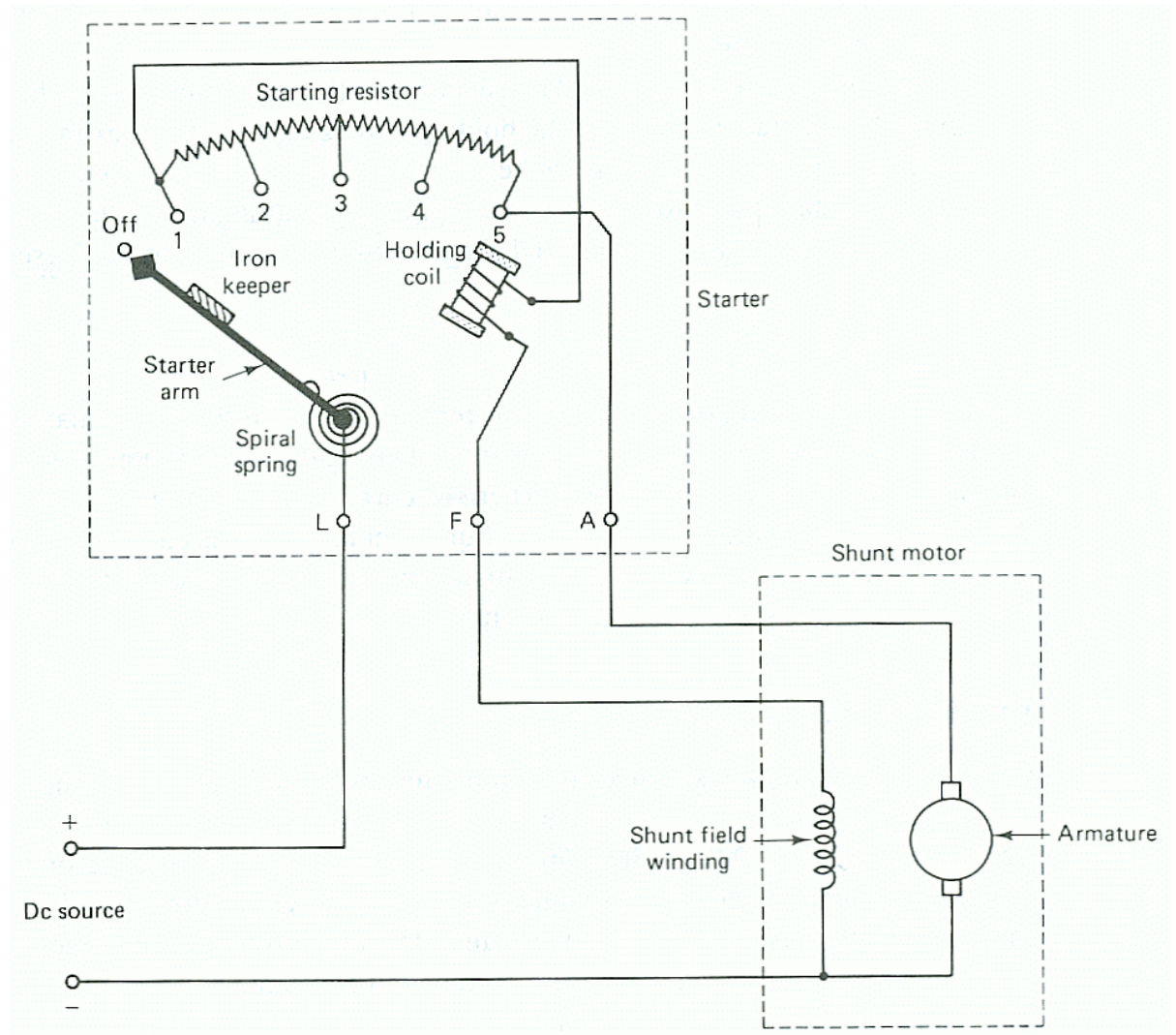



# Examples

1.
  - A shunt generator has a field resistance of  $60 \Omega$ .
  - when the generator delivers 6 kW, the terminal voltage is 120 V, while the generated EMF is 133 V.
  - Determine
    - the armature circuit resistance and
    - the generated EMF when the output is 2 kW and terminal voltage is 135 V

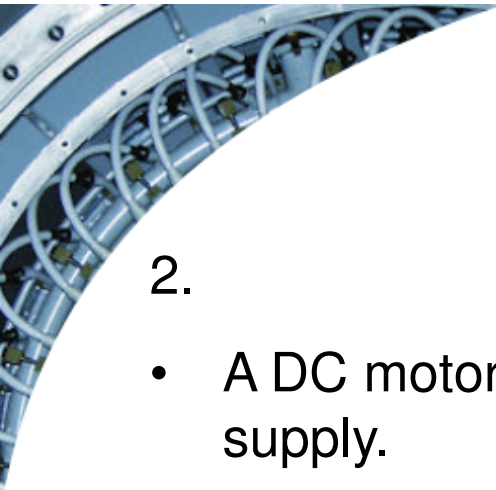

2.

- A DC motor operates at 1680 r/min when drawing 28 A from a 230-V supply.
- If the armature resistance is  $0.25 \Omega$ , and assuming all losses are neglected, calculate
  - the no-load speed;
  - the developed power under loaded conditions;
  - the torque developed under the given load

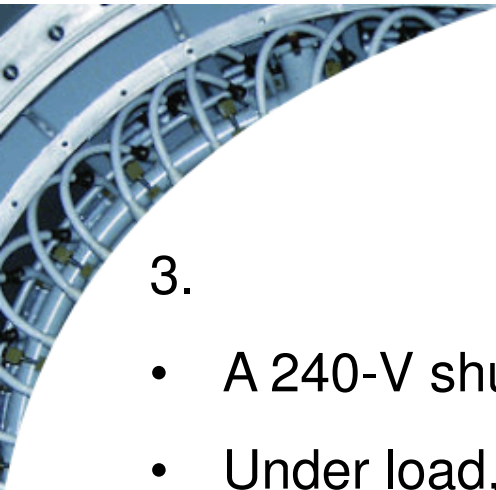

- 3.
- A 240-V shunt motor has an armature resistance of  $0.25 \Omega$
  - Under load, the armature current is 24 A
  - Suppose the flux is suddenly decreased by 2.5%
    - what would be the immediate effect on the developed torque?
    - if the motor was running at 640 r/min before the field was adjusted;
      - determine the new steady-state speed after the field has been decreased

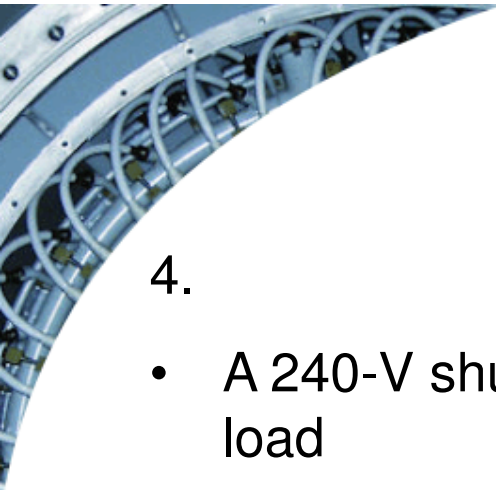

- 4.
- A 240-V shunt motor runs at 800 r/min when the armature current at no-load
  - the armature and field circuit resistance are 0.4 and 160  $\Omega$ , respectively
  - calculate the required resistance to be placed in series with the field to increase the speed to 950 r/min when armature current is 20 A

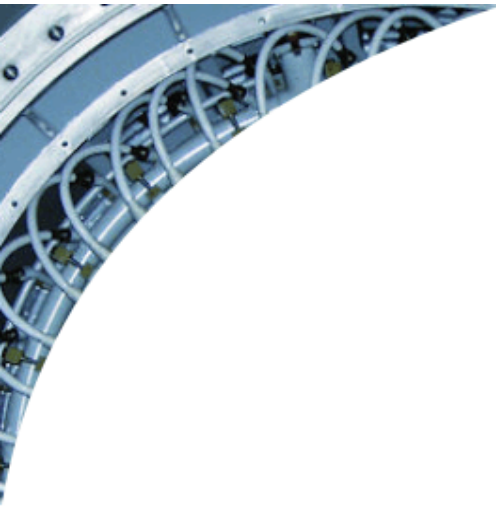

- End of Lecture 6 -