

Assignment 6&7

1. Design a circuit that will convert a 2-MHz input frequency into a 0.4-MHz output frequency.
2. Design a ripple counter circuit that will flash an LED ON for 40 ms and OFF for 20 ms (assume that a 100-Hz clock oscillator is available). (*Hint: Study the output waveforms from a MOD-6 counter.*)
3. What advantage does a synchronous counter have over a ripple counter?
4. Refer to the counter arrangement of Fig. 6.1. Determine the modulus of the counter and also the frequency of the B output and the duty cycle of the C output if the clock frequency is 600 kHz.

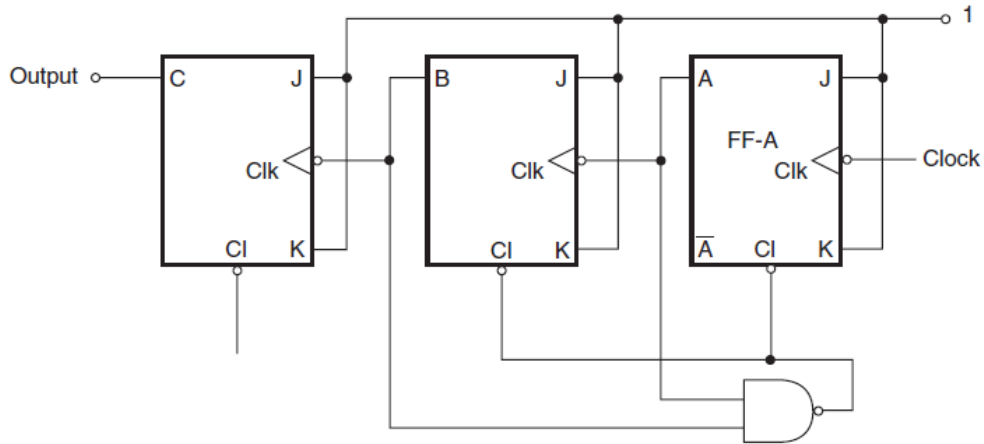

Fig 6.1

5. For the diagram in Fig 6.2 derive the equation for Q_{next} state (*Hint: $Q_{next} = D$*).

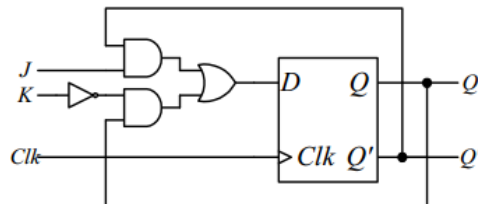

Fig 6.2

6. Given the state table below, derive the Q_{next} equation and the corresponding circuit. (Design the circuit using D flip flop)

T	Q	Q_{next}
0	0	0
0	1	1
1	0	1
1	1	0

Fig 6.3

7. Using structured programming, write VHDL code for an AND gate.
8. Distinguish between a programmable logic array (PLA) device and a programmable array logic (PAL) device in terms of architecture.
9. Determine the size of PROM required for implementing the following logic circuits.
- 16-to-1 multiplexer
 - 4-to-1 multiplexer
 - 1-of-8 decoder
10. Name any 7 components of an 8085 microprocessor
11. Name four different types of registers typically found in an 8085 microprocessor.
12. Write an assembly language program to add two numbers i.e 04 (hex) and 06 (hex) and save the sum in register C. Consequently, give the status of the following flag registers:
- Zero (Z)
 - Carry (CY)
 - Parity (P)