

# **EEE 3112 Electrical Engineering Practice**

## **Lecture 4 Commissioning**

# 1. Circuit and equipment testing

- Testing branch circuits, Receptacles, Extension cords, Plugs and cord-connected equipment



## Commissioning of Electrical Equipment

1. Objective
2. Test Instruments Required
3. Test Procedure

# 1.1 Objective

- To verify ***system condition*** after energization with rated system (service) voltage for which it is designed.
- Also to ensure the protection, metering system for correct directionality.

## 1.2 Test Instruments Required

- Multimeter
- Phase angle meter
- Phase sequence meter
- Communication software (if required)

# 1.3 Test Procedure

## Pre – Energization Checks

*The following items shall be checked without fail prior to energizing the system:*

- All pre commissioning tests should be conducted for all equipments
- A visual check of the CT (current transformer) circuits, not to be kept open.
- A visual check of the VT (voltage transformer) circuits, all the links to be closed.

- VT primary is connected to line.
- Restoration of all isolation links and connections.
- Restoration of remote alarm and indication links.
- Adaptation of relay settings.
- CB trip test at test position from protection relay by shorting contacts to ensure protection trip.
- Power cable / conductor terminated with proper tightness.

- Visual check at power transformer for power cable termination, cable box cover, oil level and cooler fan setting.
- Visual check for insulation medium level, SF6 if applicable.
- Cancellation of PTW (permit to work), other authorized documents for relevant system prior to energization.
- No admission for unauthorized personnel in the concern vicinity.
- A study of switching programme or the sequence to be executed.
- All the panel covers are closed.
- All safety action taken, like keeping fire extinguisher and first aid items.

## Post – Energization Checks

*The following points shall be checked **during and after** commissioning:*

- No abnormality in the system after energization.
- Voltage measurement shall be done for all points and found normal.
- Phase sequence check for correct rotation.
- Phasing check before paralleling two circuits by either hot stick or VT secondary side.
- If the circuit is loaded, CT secondary current of all cores and phases shall be measured with angle with respect to any one of the phase voltages.

- Directional test shall be done for directional protection, like directional O/C, E/F, and distance protection.
- Stability test shall be done for differential protection.
- If applicable, on load test for automatic voltage controller shall be done for transformer.
- Check for correct readings on indicating meters.
- Live test for auto-changer over scheme, auto-reclosing scheme shall be done

## Synhronising / Phasing Checks

### Phasing checks:

- Before making two live feeders parallel, the phasing must be checked though the source.
- This could be done in two methods. One method is hot phasing, most reliable method, since the check is done on the primary.
- The voltage difference between feeders shall be monitored by connecting a hot stick (Voltage detector equipment, rated for system voltage, that will indicate presence of voltage) between  $R_{ph}-R_{ph}$ ,  $Y_{ph}-Y_{ph}$ ,  $B_{ph}-B_{ph}$  of two feeders respectively.

- Another method is phasing between VT secondaries, and it should be ensured that there is no mistake on secondary wiring.
- To ensure correct connection of primary and secondary, energize both VTs by any one supply and do phasing between secondaries.
- For correct connection no voltage difference shall be observed during phasing.
- Now the VTs could be energized with respective feeder's supply and repeat the phasing between VT secondaries.
- If there is no considerable voltage difference between the feeders voltage, they are ready to parallel.

- **Synchronising Check:**

*Before connecting a different source of same voltage level, in addition to phasing check, synchronization must be done. The following steps shall be followed.*

- Adopt proper setting for synchro-check relay.
- Check the secondary grounding for all VTs that they are at same point (star point or Y phase).
- Energize both VTs with same source.
- Do phasing between VT secondaries, check synchro-check relay picks up continuously and synchroscope is staying at 12'o clock position. This ensures that the primary and secondary connections of VTs are correct.

- Now energize the VTs with respective sources.
- Check that the synchroscope pointer continues to rotate.
- This rotation (incoming voltage vector is rotating with respect to running voltage) is due to slip frequency between the sources, i.e., phase angle between the voltages varying time to time due to frequency difference of supplies.
- If the observed rotation is fast, try to make it slow by increasing or decreasing speed of the machines.
- Once the rotation is slow, when the incoming voltage phase angle difference falls within the set value, the synchronising relay picks up and drops off as soon as the phase angle difference is exceeded.
- It is allowed to parallel the sources within this period.

## 2. Directional Test

- This test verifies the directional protection / distance relay is looking in the desired direction (trip direction).
- This could be confirmed by on load test.
- The principle of the test is that the load current and voltage shall be simulated in trip direction and observe the relay operation.
- The VT or CT input to the relay shall be reversed and observe the relay is reset.

## 3. On-Load Stability Test

This test is used to confirm the stability of a ***differential protection*** for through fault with load current.

*The following precautions shall be taken during the test.*

- Protection shall be put out of service, i.e. all out put contacts are isolated.
- Never open CT circuit.
- At the end of the test all the connections shall be restored back.

## 4. Transformer Differential protection:

- The current inputs to the relay from all the windings of the transformer shall be measured with an angle WRT any phase voltage of VT.
- The differential current is also measured externally or internally by a relay.
- There should be no differential current (practically not zero) during this test.
- If sufficient load is not available on the transformer, this test could be done by making two transformers parallel and keeping at different taps (A circulating current will be flowing between them).

## 5. Pilot wire differential protection:

- The CT currents at both ends shall be measured with phase angle.
- The pilot current shall be measured between the relays at normal load condition.

*The following steps are followed.*

- Isolate trip and alarm.
- Enable the pilot wire relay with O/C check input energized (if applicable).
- Measure the relay CT input current at both ends in all phases.

- Measure the pilot current with normal pilot connection.
- Connect only 'R' phase CT to the relay and other phase's CT short and isolate at both ends.
- Now check the pilot current and observe that the relay is stable.
- Reverse the pilot connection and measure the pilot current. The pilot current should reduce and relay operates for correct function.
- It shall be repeated for 'Y','B','RY','YB','BR','RYB' combinations.

# 6. Busbar differential protection:

- The entire feeder's current shall be measured with phase angle.
- The differential current at main relay and voltage across CT bus shall be measured.
- At normal load condition there should be no differential current and voltage.

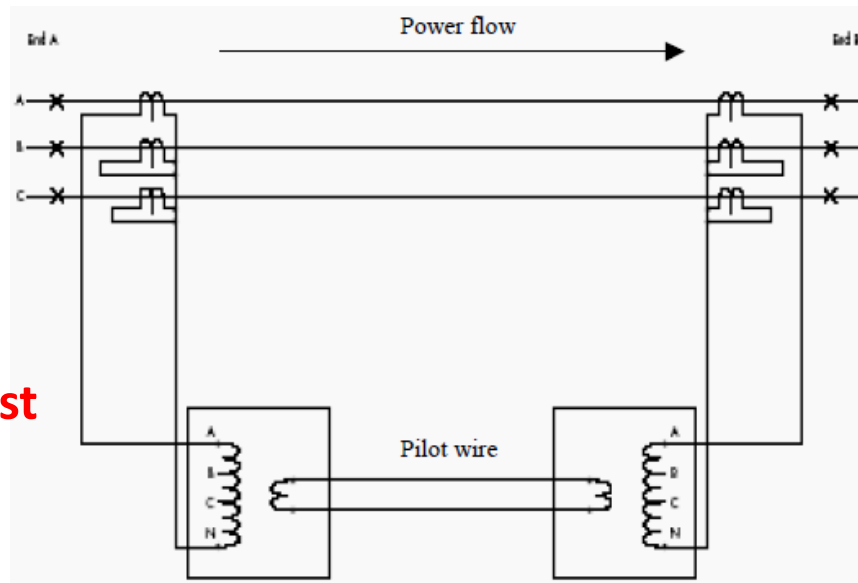

**Pilot wire protection on load test**

# 7. Metering Verification

- Sometimes it is important to check the meter reading with actual inputs for correct polarity, particularly in power and energy measurement.
- For power meter the input current and voltage shall be measured with angle.

# 8. Circuit breaker analysis systems

- When a fault such as a short circuit or current overload is detected by a protective relay, a trip impulse is sent to the circuit breaker.
- The circuit breaker must function as specified and interrupt the current as soon as possible or severe damage may occur.



- The damage caused by a malfunctioning circuit breaker can often be catastrophic, resulting in significant damage to the electrical system.
- Given that circuit breakers may be inactive for months or even years prior to a fault, a regime of circuit breaker testing is an important safety factor.
- Proper functionality of a breaker is reliant on a number of individual components that have to be calibrated and tested at regular intervals to ensure the complete and successful breaking of the circuit when triggered.
- Poorly maintained circuit breakers may not activate after receiving the trigger signal sent by the protection relay.

**End of lectures on Power!**