

EEE3112 Electrical Engineering Practice

Lecture 2

Protection of Electrical Equipment

1. Lightning Protection

- It is important to protect buildings and lives against lightning strikes.
- **Lightning** is a sudden electrostatic discharge during an electrical storm between electrically charged regions of a cloud (called intra-cloud **lightning** or IC), between a cloud and another cloud (CC **lightning**), or between a cloud and the ground (CG **lightning**).



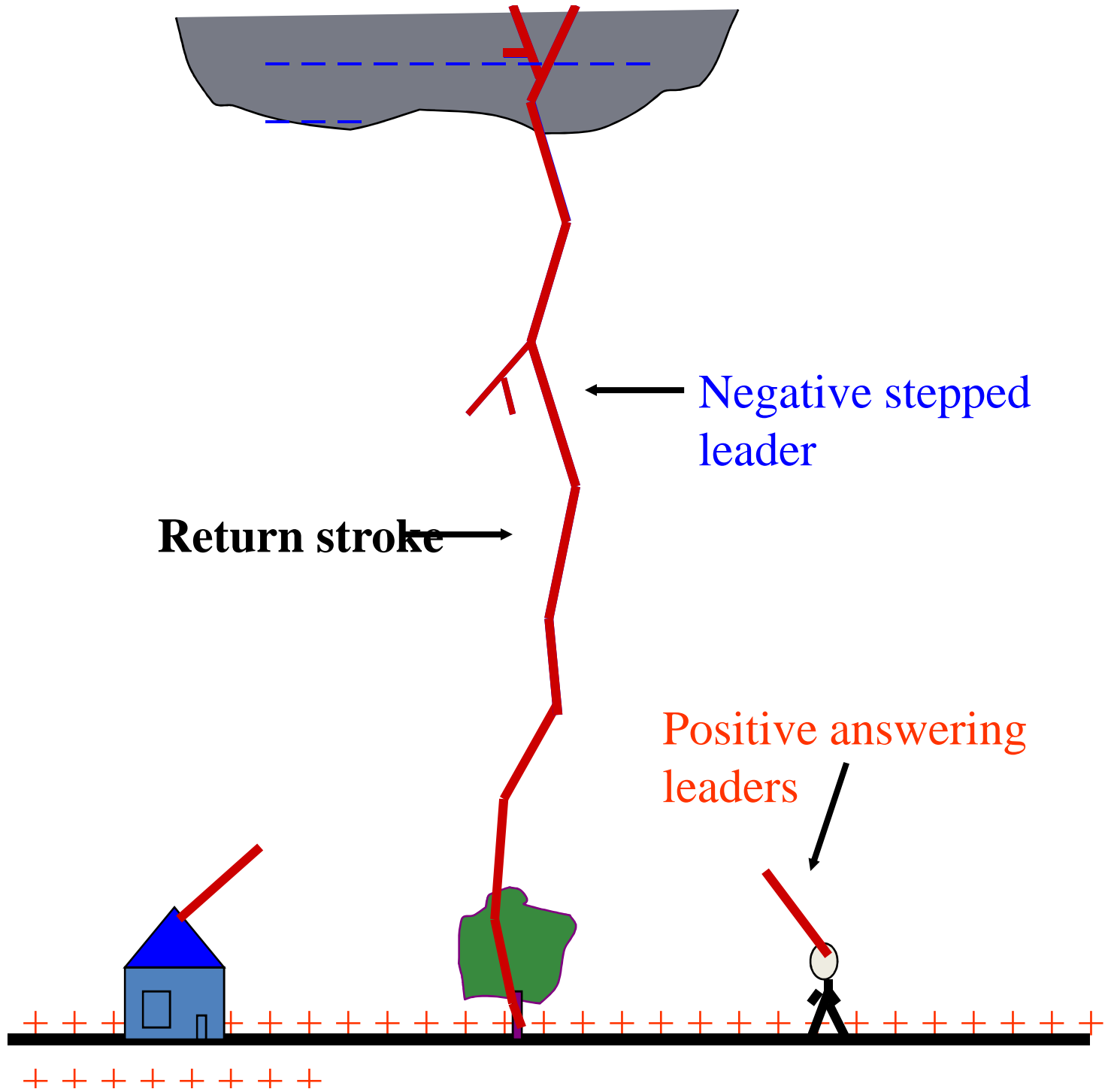

The point of interception with lightning stepped leader depends on:

Height of the point

Shape of the point

Conductivity of the
structure

Earth Resistance

1.1 Lightning Characteristics

- Temperature
50,000 degrees F/27760 degree Celsius
- Intensity
25,000 Amperes
200,000,000 Volts or more
- Size
One inch in diameter
- Velocity
One third the speed of light

1.2 Lightning safety

- Certain safety:

- Inside a large substantial frequently-occupied building

- Inside a fully-enclosed metal-topped vehicle

- Not certain safety:

- What a person wears or carries something

- Where or how a person stands

- On what a person stands

- Anywhere outside

1.3 Safe structures

- **Large substantial buildings**
- **Where people frequently live or work**
- **Have grounded wiring and plumbing, and metal structural members**
- **Follow building codes**
- **Surround people inside with a Faraday cage-like effect to provide safe path for lightning to flow to ground**

1.4 Completely unsafe structures

Tents

--No safety from lightning

Thatched roof

--No safety from lightning



1.5 How does lightning cause problems

* Potential rise that may cause

surface or air arcing,
current through bodies in contact
(touch and step potentials)

Thermal effects that may cause

Melting of current path
Igniting materials in the vicinity

1.6 Main components of a Lightning Protection System (LPS)

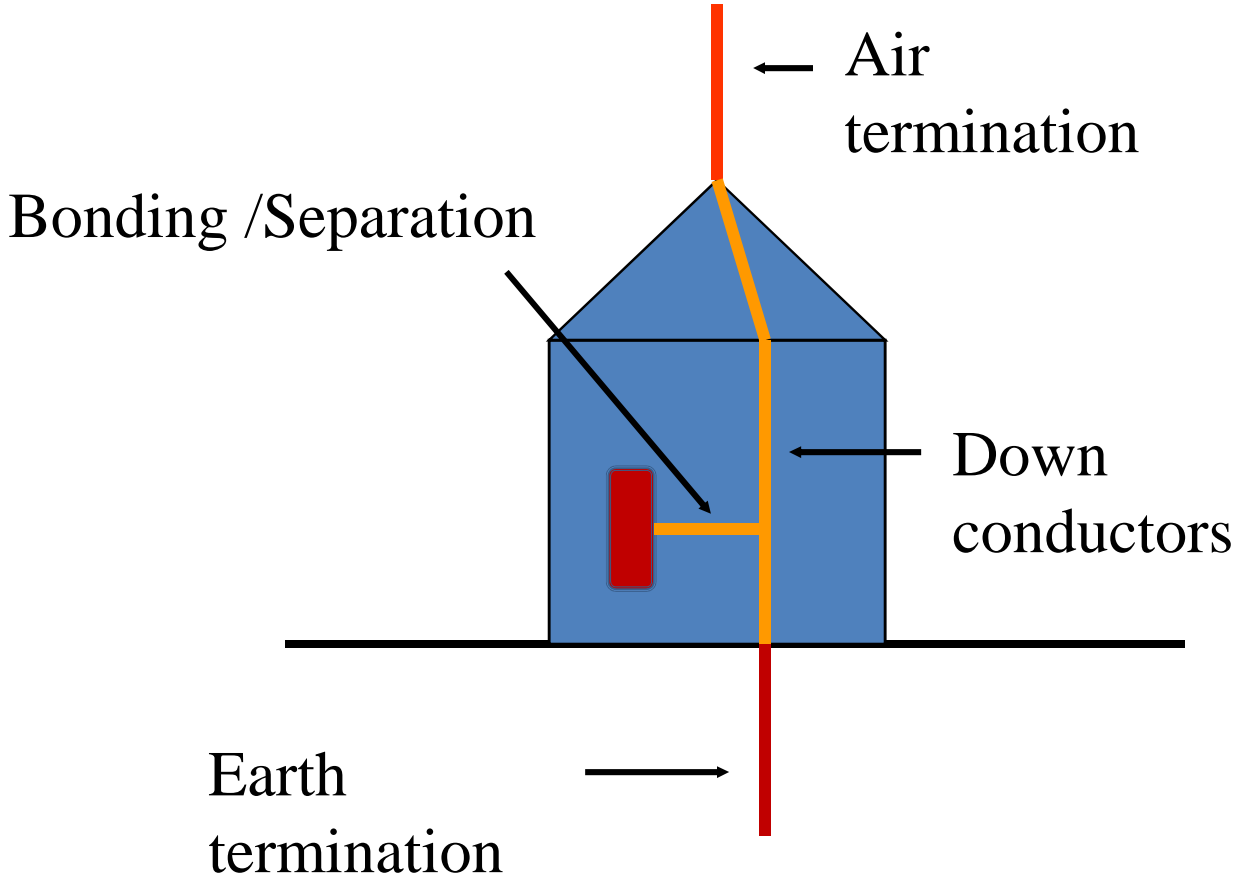



Ring earthing
House with tiled roof

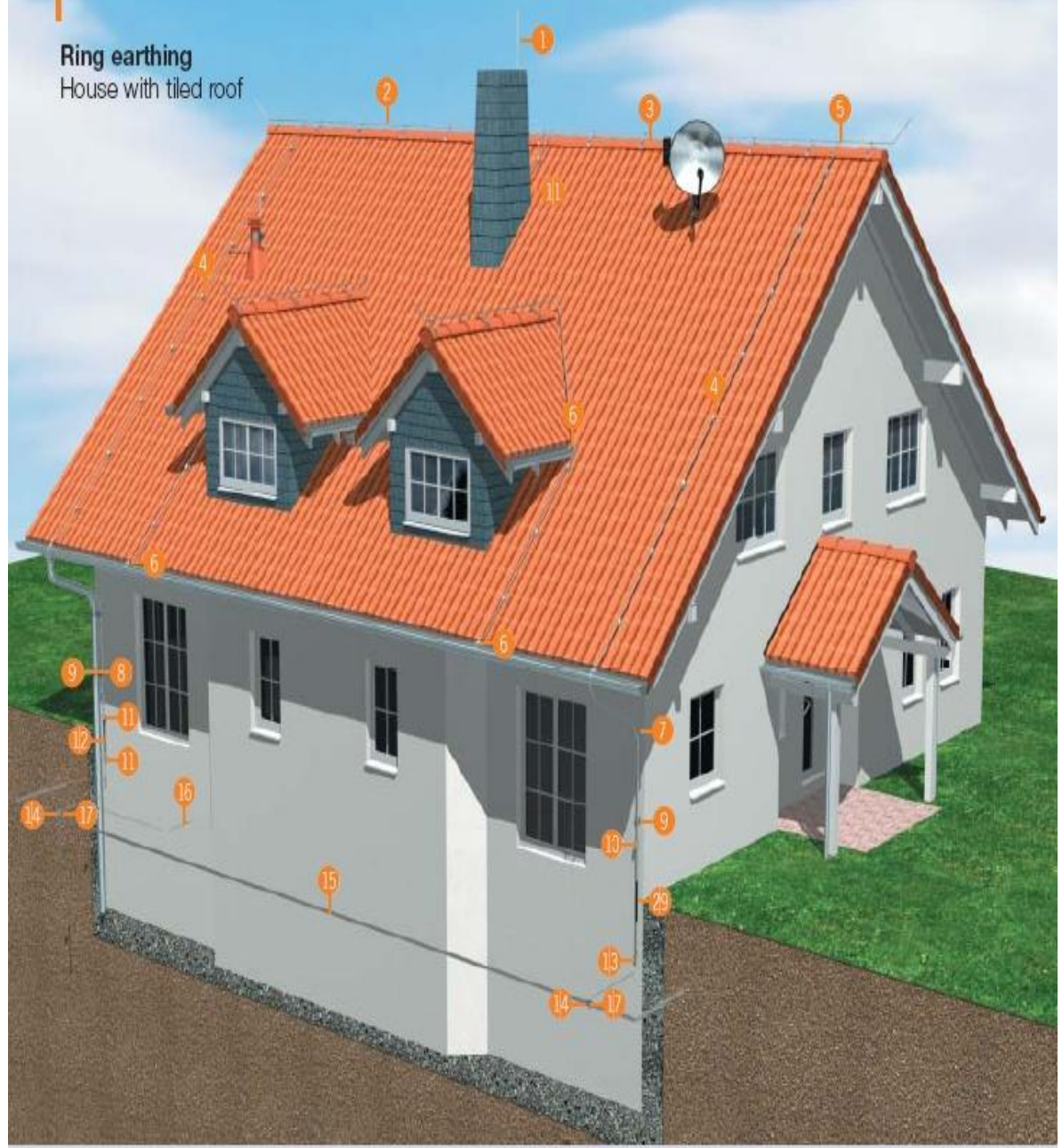

2. Wiring Systems

T T Wiring System

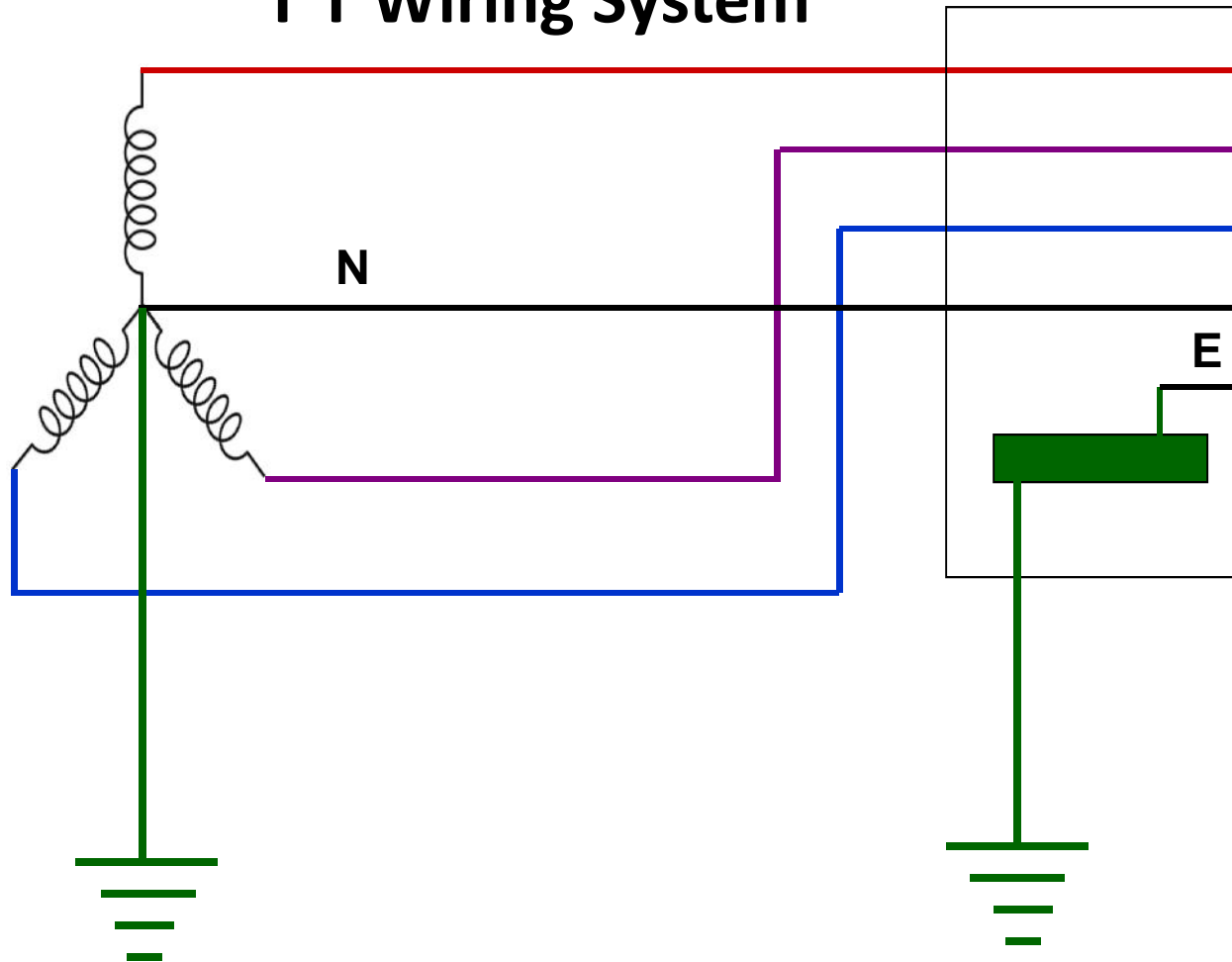

T N S Wiring System

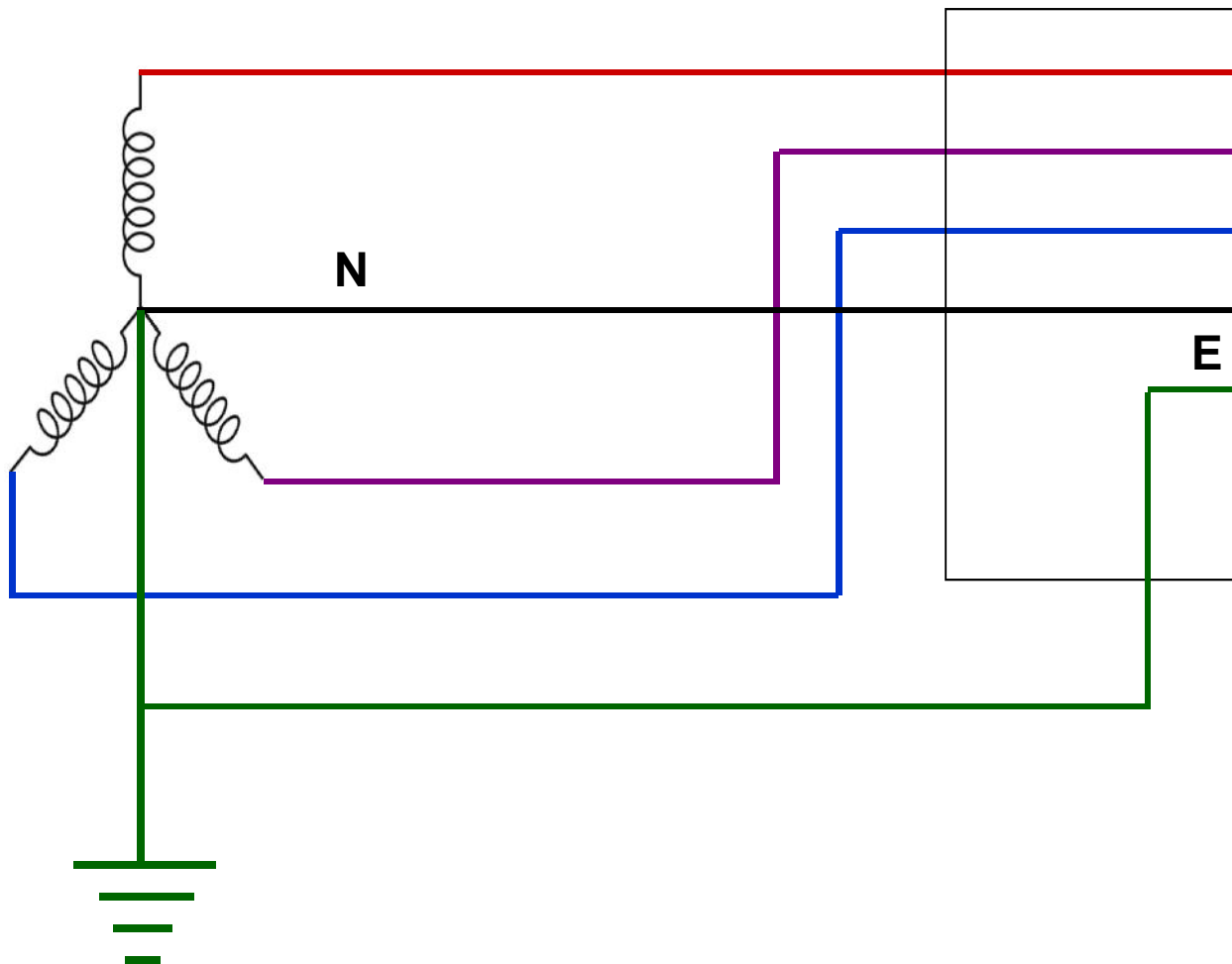

T N C Wiring System

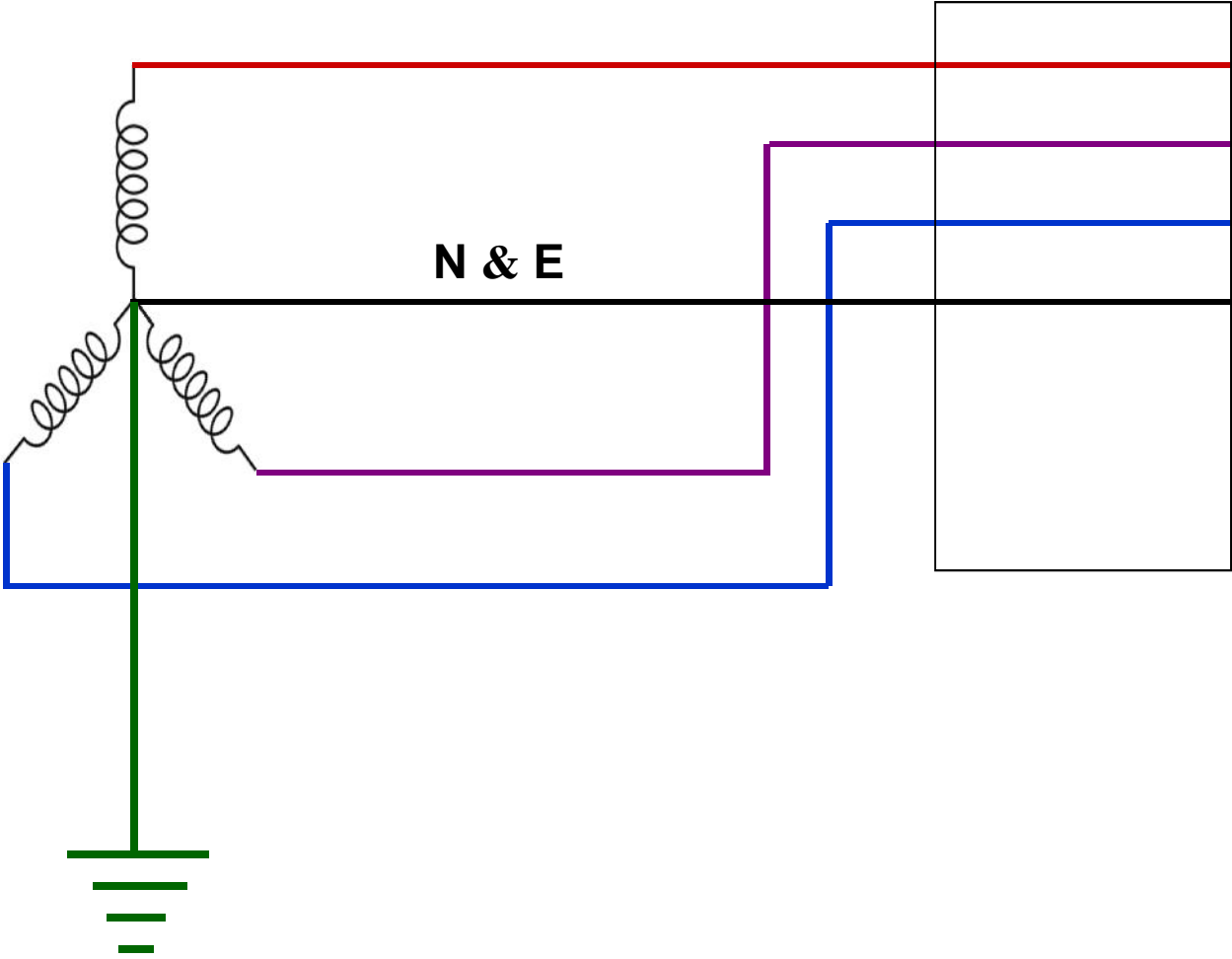

T N C S Wiring System

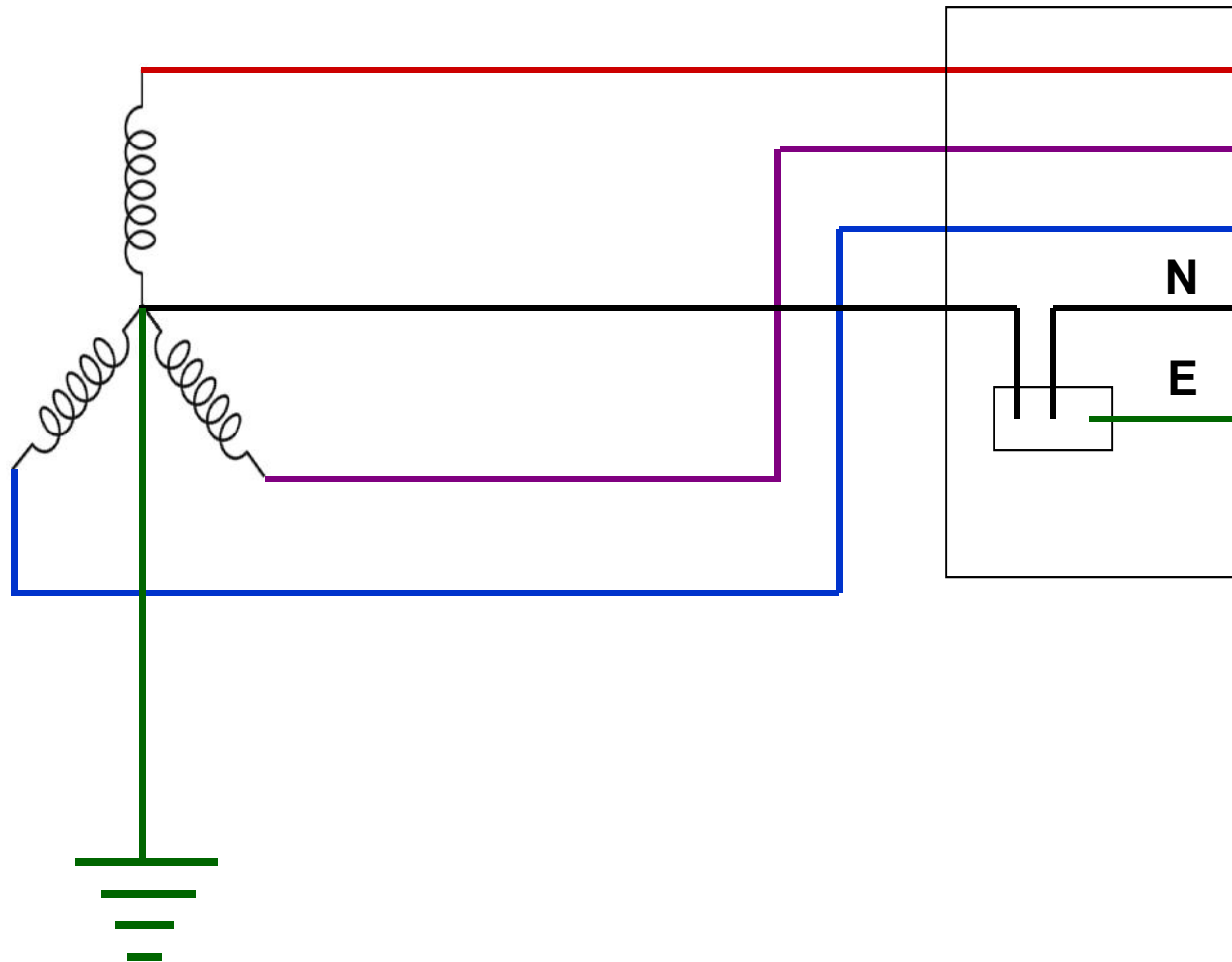

An Example on a Home Lighting System

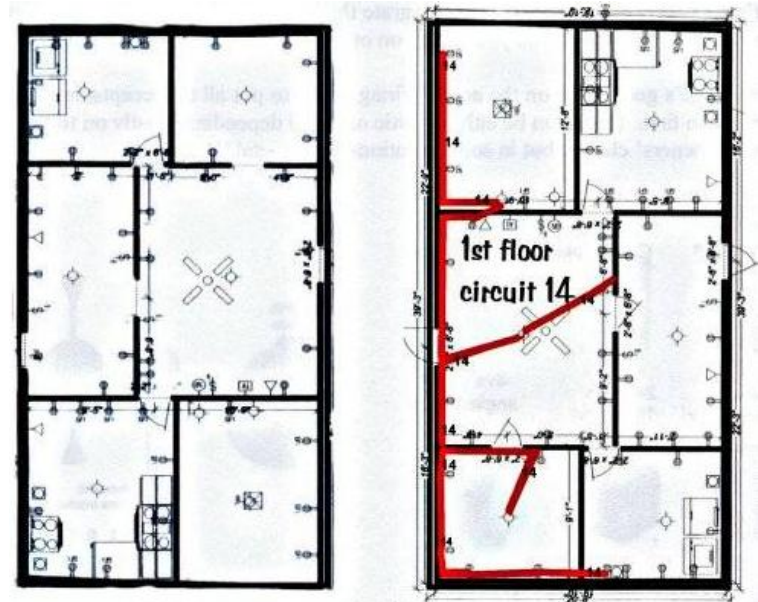
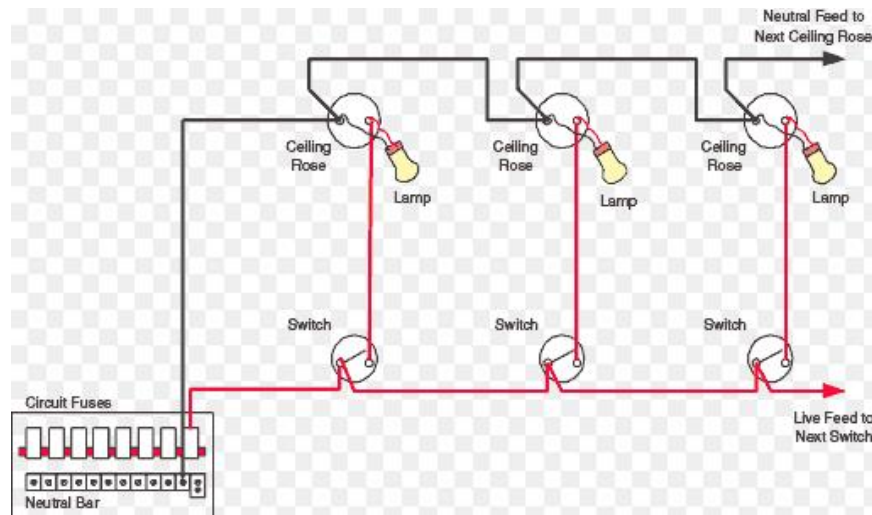
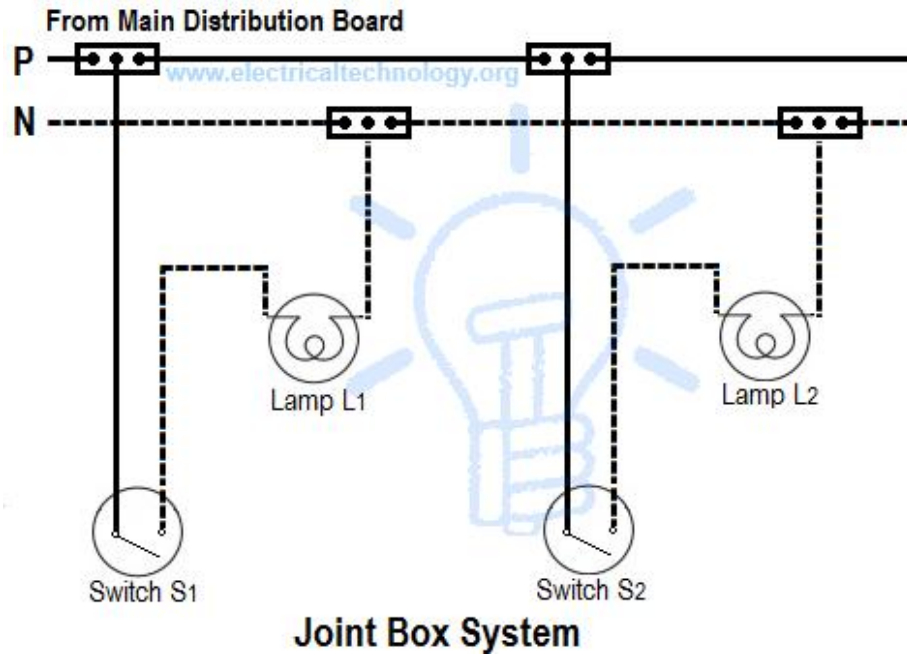

Modes of Damage

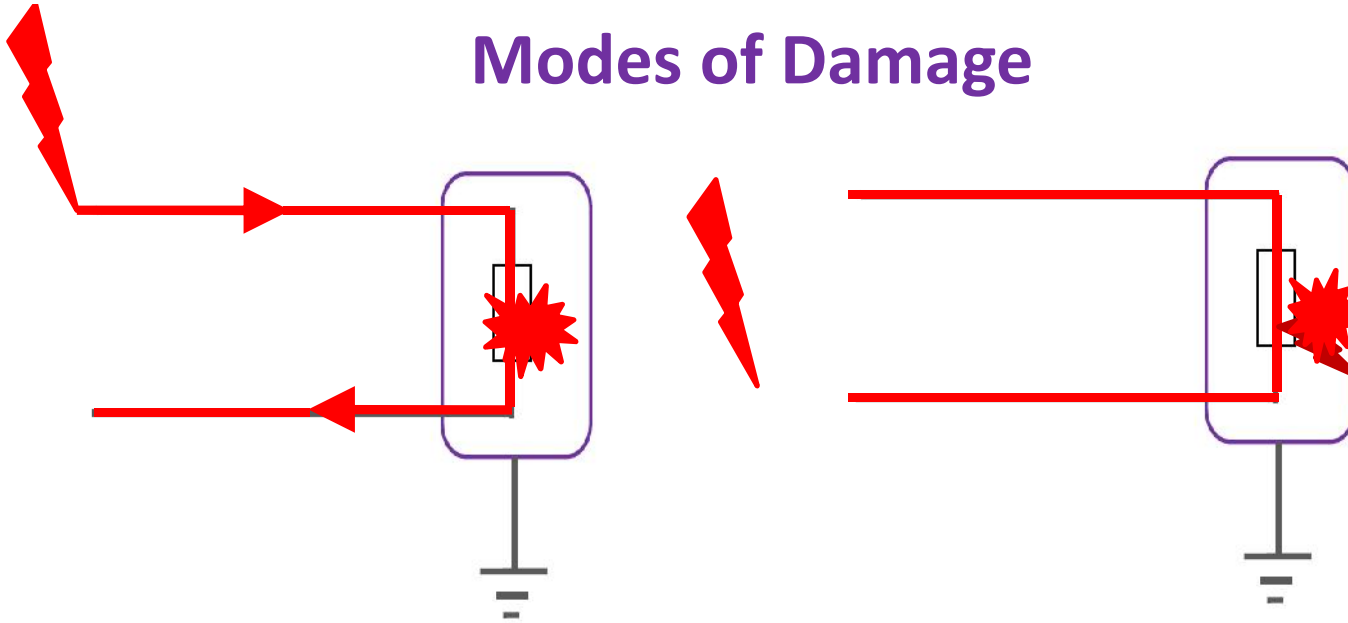

Differential Mode Transients:
most often cause over-current
heating

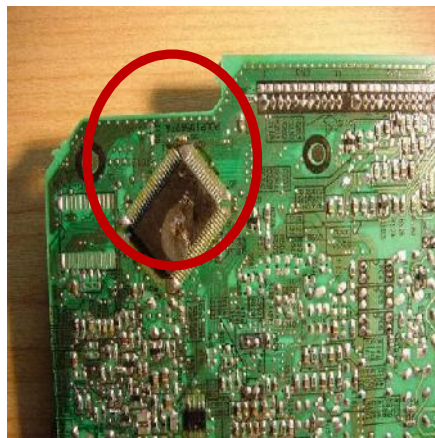

Common Mode Transients:
most often cause dielectric
damage



3. Surge Protection Devices

SPD Operation - 1

Lightning to the line or close to the line



Voltage impulse

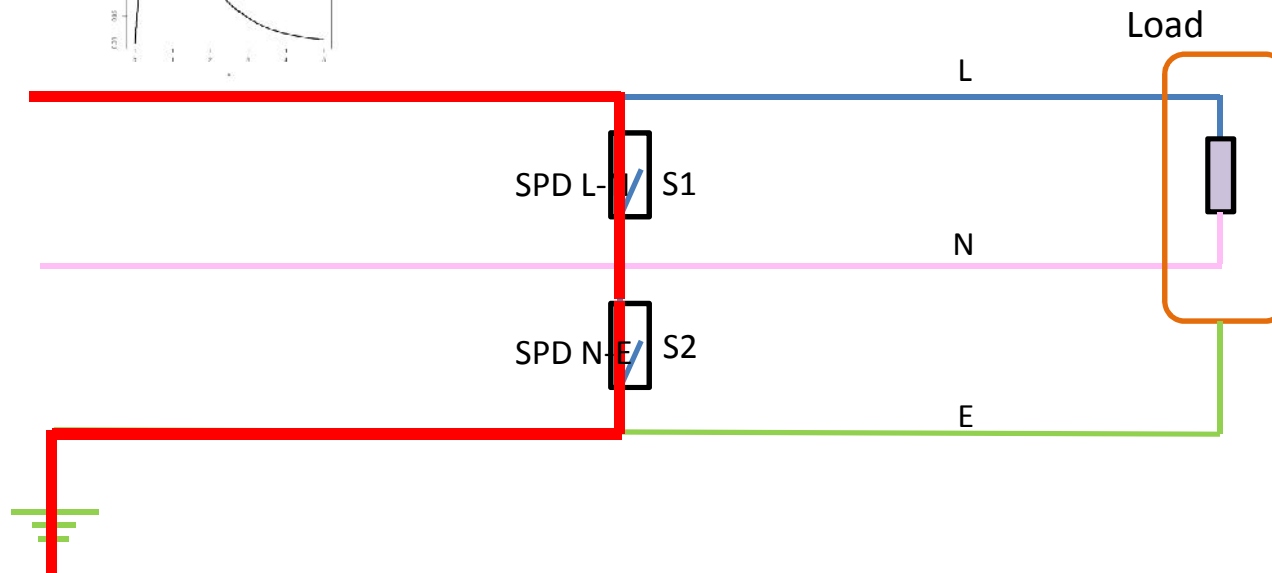
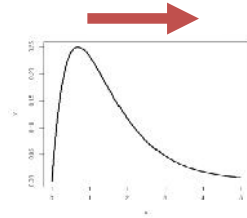

SPD Operation - 2

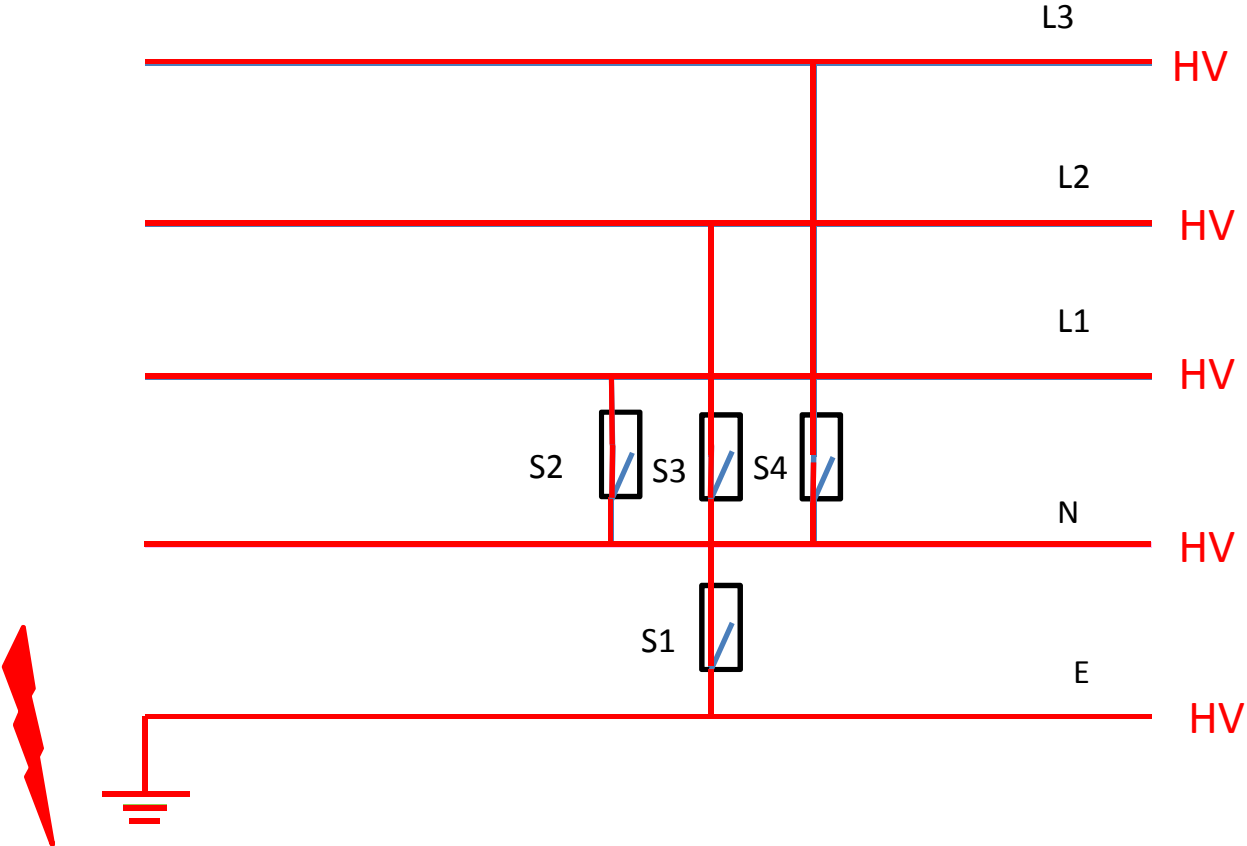

Selection of SPDs for power Systems

- Where to install: main panel, sub panels, plug etc.
- Impulse Current handling Capacity
- Let through voltage (Voltage protection level)
- Response time
- Maximum Continuous Operating Voltage (MCOV)

Selection of SPDs on communication and Data Lines

- System operating current and voltage
- Bandwidth and insertion losses
- No of pins (lines) & cable type
- Plug type

4. Standards

IEC 62305-1 (2010): Protection against lightning - General principles

IEC 62305-2 (2010): Protection against lightning - Risk management

IEC 62305-3 (2010): Protection against lightning - Physical damage and life hazard

IEC 62305-4 (2010): Protection against lightning - Electrical and electronics systems

IEC 62305-5 (2010): Protection against lightning - supply lines

NFPA 780 (2014): Standard for the installation of lightning protection systems

AS/NZS 1768 (2007): Lightning protection

SANS 10313 (2010): Protection against lightning — Physical damage to structures and life hazard

5. Ground Fault Circuit Interrupter

- A **ground fault circuit interrupter (GFCI)** or Residual Current Device (RCD) is a device that shuts off an electric power **circuit** when it detects that current is flowing along an unintended path, such as through water or a person.
- A GFCI works by measuring the current leaving one side of a power source (the so-called "live" or "hot wire"), and comparing it to current returning on the other (the "neutral" side).
- If they are not equal, then some of the current must be leaking in an unwanted way, and the GFCI shuts the power off.

- GFCIs are available in two types for permanent installations: (1) the circuit breaker type that is installed in an electrical panel, and the receptacle type that is installed in a normal electrical outlet box.
- GFCIs attached to appliance cords, or built into extension cords, are also available.
- GFCIs are usually required by local laws to be installed in kitchens, bathrooms, unfinished basements, garages, outdoors, and anywhere near a sink. Notably, these are all places where water may allow a short circuit to happen.



The Receptacle Type incorporates a GFCI device within one or more receptacle outlets. Such devices are becoming popular because of their low cost.

- Ground-fault circuit interrupters (GFCIs) have been in use for many years now, and have proven themselves to be invaluable in the protection of personnel from the hazard of electric shock.
- Other types of leakage current and ground fault protective devices have been introduced for various applications since the introduction of GFCIs.
- Note that an electrical outlet or receptacle is a socket that connects an electrical device to an electricity supply. In buildings, electrical outlets are usually installed in the wall, although they can also be installed in the floor.

The GFCI's features

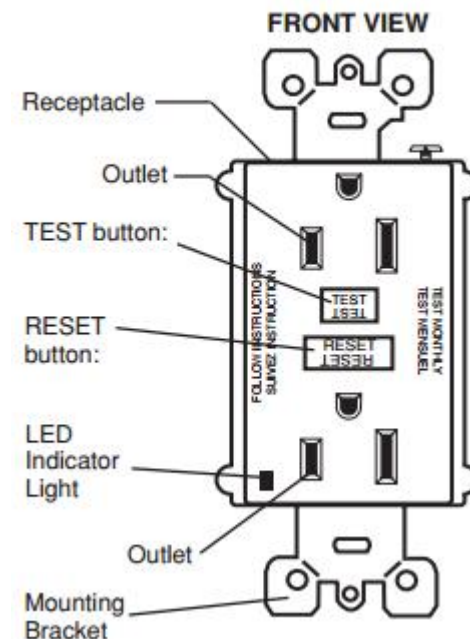

6. Lightning Arresters

- A **lightning arrester** is a device used on electrical power systems and telecommunications systems to protect the insulation and conductors of the system from the damaging effects of **lightning**.
- The typical **lightning arrester** has a high-voltage terminal and a ground terminal.
- When a lightning surge (or switching surge, which is very similar) travels along the power line to the arrester, the current from the surge is diverted through the arrester, in most cases to earth.

6.1 Complete Overview of Lightning Arresters

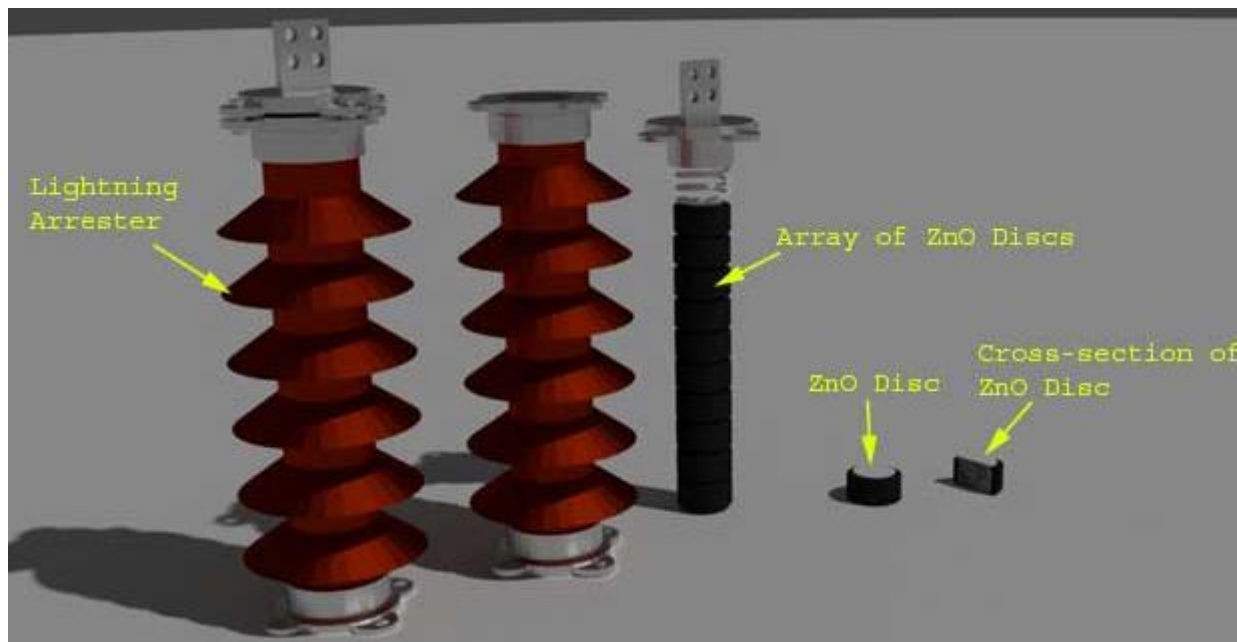

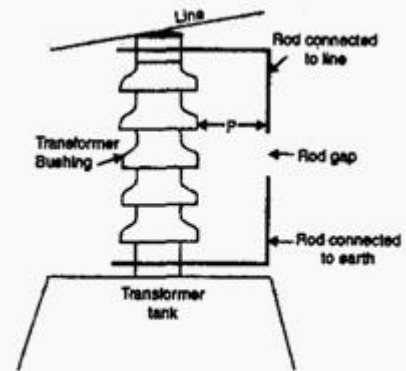

Rod arrester

7. Unza Demo Substations

Substation 1

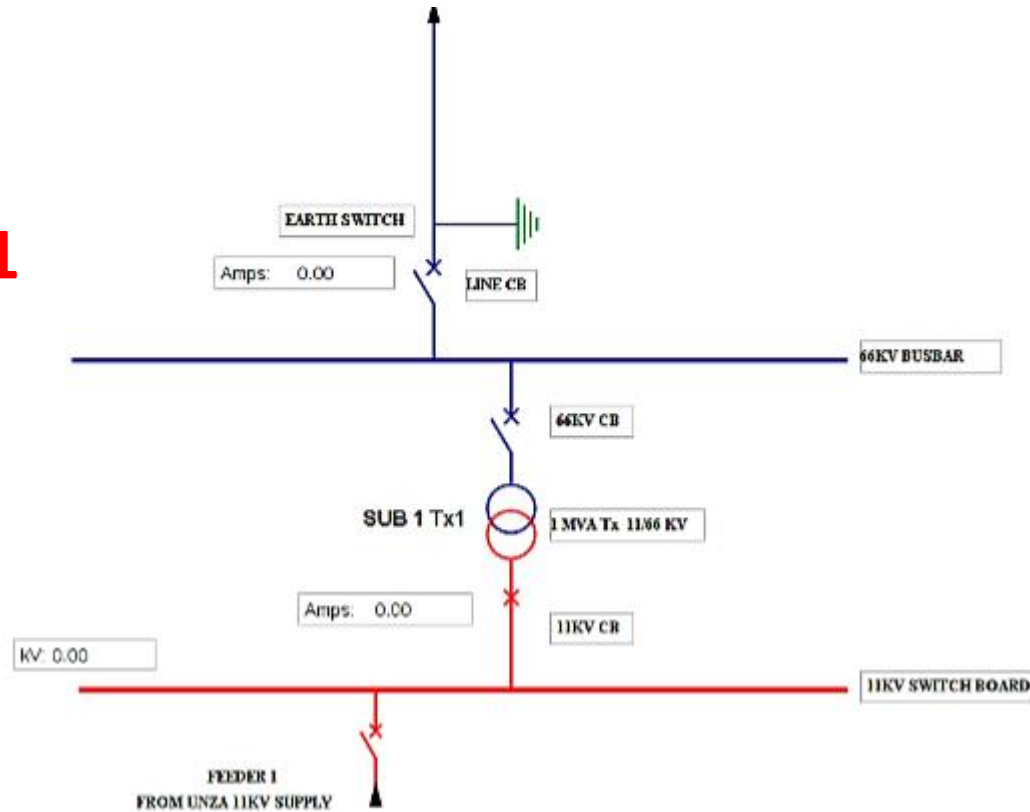

Substation 2

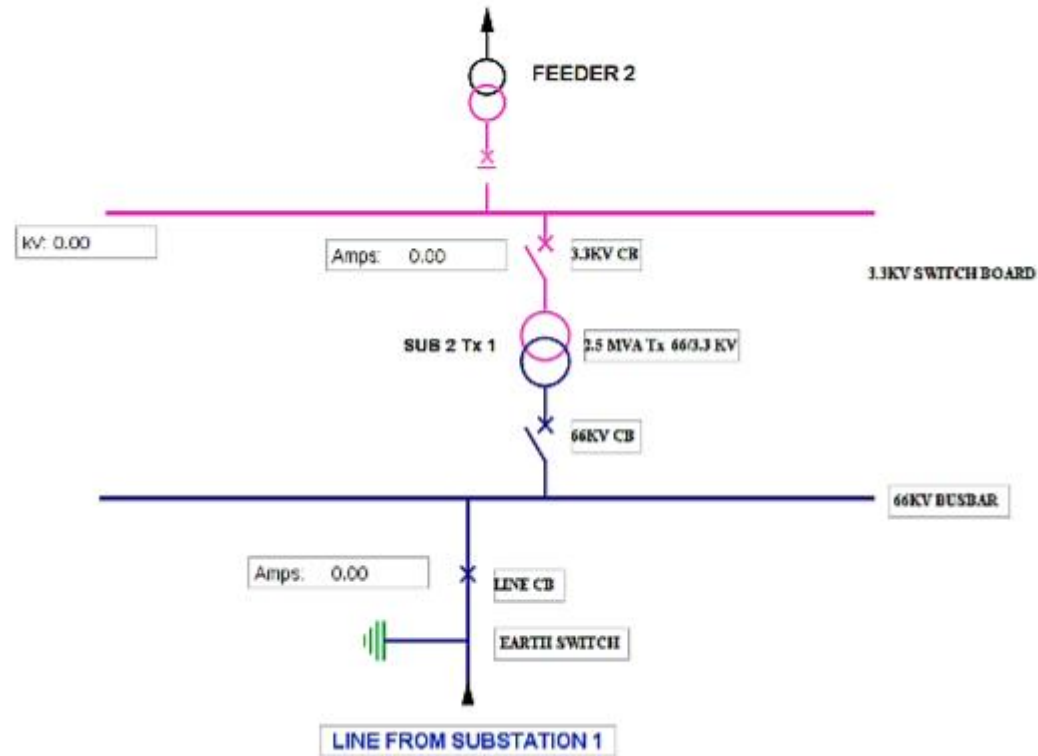

Homework

- Study the two substations above and link them up in one single-line diagram. Explain the functions of some of the features that you can see.

End of Lecture!