

Homework 3 Model Solution

Section 12.6 ~ 13.1.

12.6.3 Describe and sketch the surface

$$x^2 + z^2 = 1.$$

If we cut the surface by a plane $y = k$ which is parallel to xz -plane, the intersection is $x^2 + z^2 = 1$ on a plane, which is a circle of radius 1 whose center is $(0, k, 0)$. Therefore the surface is a union of all such circles, that is, a circular cylinder.

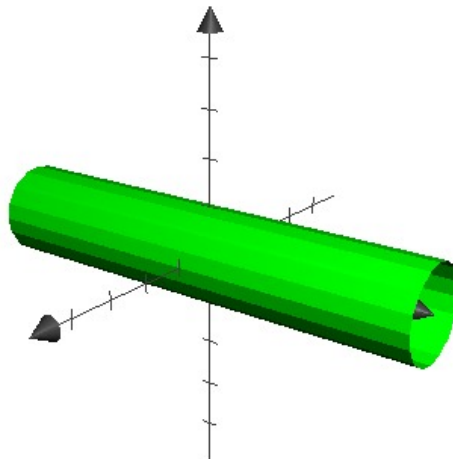

12.6.8 Describe and sketch the surface

$$z = \sin y.$$

The intersection with a plane $x = k$ is $z = \sin y$, the graph of sine function. It does not depend on the intersection plane $x = k$, so it is a cylinder whose base is a sine curve.

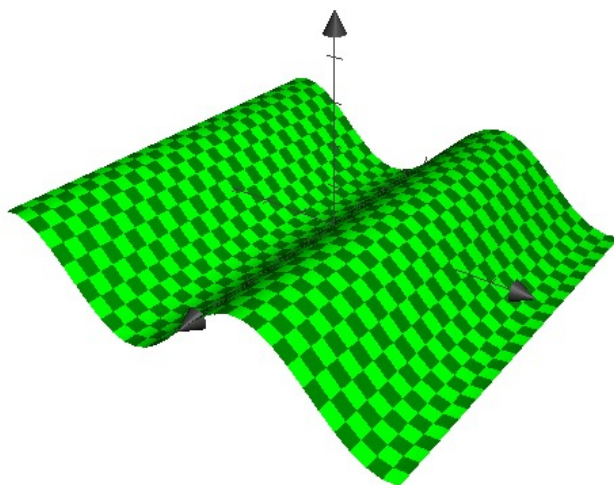

- 12.6.9 (a) Find and identify the traces of the quadric surface $x^2 + y^2 - z^2 = 1$ and explain why the graph looks like the graph of the hyperboloid of one sheet in Table 1.

$$x = k \Rightarrow k^2 + y^2 - z^2 = 1 \Rightarrow y^2 - z^2 = 1 - k^2$$

The trace is a hyperbola when $k \neq \pm 1$. If $k = \pm 1$, $y^2 - z^2 = (y+z)(y-z) = 0$, so it is a union of two lines.

$$y = k \Rightarrow x^2 + k^2 - z^2 = 1 \Rightarrow x^2 - z^2 = 1 - k^2$$

The trace is a hyperbola when $k \neq \pm 1$. If $k = \pm 1$, $x^2 - z^2 = (x+z)(x-z) = 0$, so it is a union of two lines.

$$z = k \Rightarrow x^2 + y^2 - k^2 = 1 \Rightarrow x^2 + y^2 = 1 + k^2$$

The trace is a circle whose radius is $\sqrt{1 + k^2}$.

Therefore the surface is a stack of circles, whose traces of other directions are hyperbola. So it is a hyperboloid. The intersection with the plane $z = k$ is never empty. This implies the hyperboloid is connected.

- (b) If we change the equation in part (a) to $x^2 - y^2 + z^2 = 1$, how is the graph affected?

The role of y and z are interchanged. So now the axis of given hyperboloid is y -axis.

- (c) What if we change the equation in part (a) to $x^2 + y^2 + 2y - z^2 = 0$?

$$\begin{aligned} x^2 + y^2 + 2y - z^2 = 0 &\Rightarrow x^2 + y^2 + 2y + 1 - z^2 = 1 \\ &\Rightarrow x^2 + (y + 1)^2 - z^2 = 1 \end{aligned}$$

Thus it is a translation of the hyperboloid $x^2 + y^2 - z^2 = 1$ by $(0, -1, 0)$.

12.6.16 Use traces to sketch and identify the surface

$$4x^2 + 9y^2 + z = 0.$$

$$x = k \Rightarrow 4k^2 + 9y^2 + z = 0 \Rightarrow z = -9y^2 - 4k^2$$

The trace is a parabola.

$$y = k \Rightarrow 4x^2 + 9k^2 + z = 0 \Rightarrow z = -4x^2 - 9k^2$$

The trace is a parabola.

$$z = k \Rightarrow 4x^2 + 9y^2 + k = 0 \Rightarrow 4x^2 + 9y^2 = -k$$

The trace is empty set, if $k > 0$. If $k \leq 0$, the trace is an ellipse.

By looking at the traces $z = k$, we can regard the surface as a stack of ellipses. Also its first and second traces are parabolas. So it is an elliptic paraboloid.

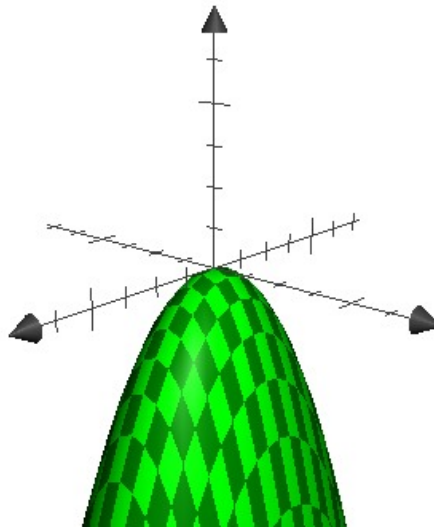

12.6.18 Use traces to sketch and identify the surface

$$4x^2 - 16y^2 + z^2 = 16.$$

$$x = k \Rightarrow 4k^2 - 16y^2 + z^2 = 16 \Rightarrow -16y^2 + z^2 = 16 - 4k^2$$

The trace is a hyperbola.

$$y = k \Rightarrow 4x^2 - 16k^2 + z^2 = 16 \Rightarrow 4x^2 + z^2 = 16 + 16k^2$$

The trace is an ellipse.

$$z = k \Rightarrow 4x^2 - 16y^2 + k^2 = 16 \Rightarrow 4x^2 - 16y^2 = 16 - k^2$$

The trace is a hyperbola.

So the surface is a stack of ellipses (traces in different directions are hyperbolas).
It is a hyperboloid.

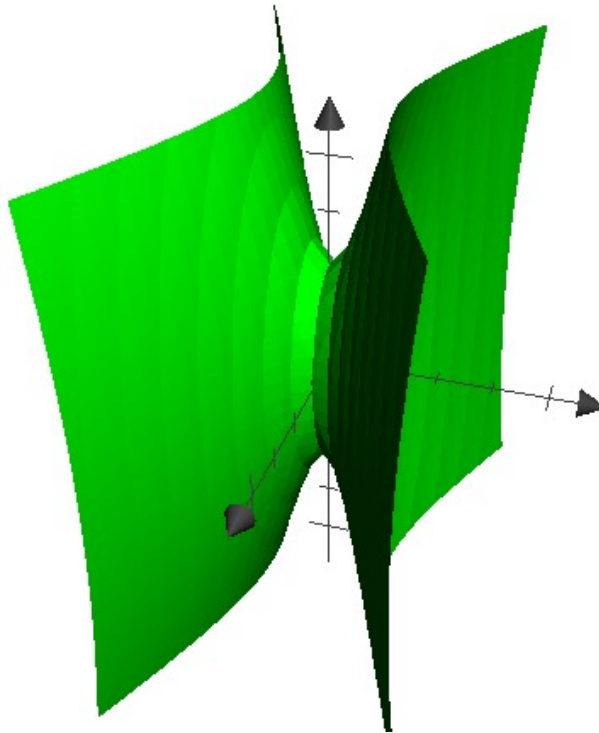

12.6.34 Reduce the equation

$$4y^2 + z^2 - x - 16y - 4z + 20 = 0$$

to one of the standard forms, classify the surface, and sketch it.

$$\begin{aligned} 4y^2 + z^2 - x - 16y - 4z + 20 &= 0 \\ \Rightarrow 4y^2 - 16y + z^2 - 4z + 20 &= x \\ \Rightarrow 4y^2 - 16y + 16 + z^2 - 4z + 4 &= x \\ \Rightarrow 4(y - 2)^2 + (z - 2)^2 &= x \end{aligned}$$

Therefore it is a translation of an elliptic paraboloid $4y^2 + z^2 = x$ by a vector $\langle 0, 2, 2 \rangle$.

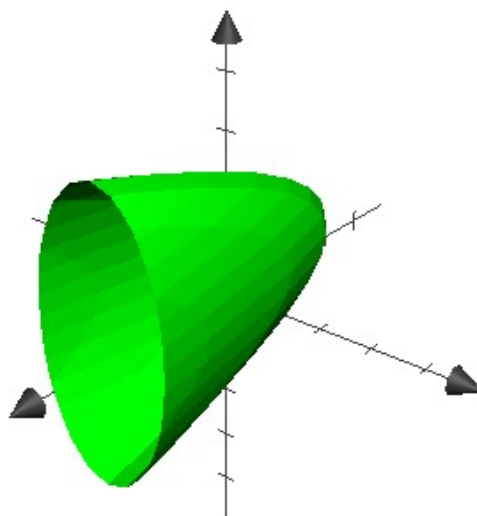

12.6.47 Traditionally, the earth's surface has been modeled as a sphere, but the World Geodetic System of 1984 (WGS-84) uses an ellipsoid as a more accurate model. It places the center of the earth at the origin and the north pole on the positive z -axis. The distance from the center to the poles is 6356.523 km and the distance to a point on the equator is 6378.137 km.

- (a) Find an equation of the earth's surface as used by WGS-84.

For a general equation

$$\frac{x^2}{a^2} + \frac{y^2}{b^2} + \frac{z^2}{c^2} = 1,$$

the distance from the origin to x -intercept (y , z -intercepts respectively) is a (b , c respectively). From the description above, the equation of the earth's surface is

$$\frac{x^2}{(6378.137)^2} + \frac{y^2}{(6378.137)^2} + \frac{z^2}{(6356.523)^2} = 1.$$

- (b) Curves of equal latitude are traces in the planes $z = k$. What is the shape of these curves?

$$\begin{aligned} z = k &\Rightarrow \frac{x^2}{(6378.137)^2} + \frac{y^2}{(6378.137)^2} + \frac{k^2}{(6356.523)^2} = 1 \\ &\Rightarrow \frac{x^2}{(6378.137)^2} + \frac{y^2}{(6378.137)^2} = 1 - \frac{k^2}{(6356.523)^2} \\ x^2 + y^2 &= \left(1 - \frac{k^2}{(6356.523)^2}\right) (6378.137)^2 \doteq 40680631.591 - 1.007k^2 \end{aligned}$$

It is a circle.

- (c) Meridians (curves of equal longitude) are traces in planes of the form $y = mx$. What is the shape of these meridians?

$$\begin{aligned}
 y = mk &\Rightarrow \frac{x^2}{(6378.137)^2} + \frac{(mx)^2}{(6378.137)^2} + \frac{z^2}{(6356.523)^2} = 1 \\
 &\Rightarrow \frac{(1+m^2)x^2}{(6378.137)^2} + \frac{z^2}{(6356.523)^2} = 1
 \end{aligned}$$

It is an ellipse.

12.6.49 Show that if the point (a, b, c) lies on the hyperbolic paraboloid $z = y^2 - x^2$, then the lines with parametric equations $x = a + t, y = b + t, z = c + 2(b - a)t$ and $x = a + t, y = b - t, z = c - 2(b + a)t$ both lie entirely on this paraboloid. (This shows that the hyperbolic paraboloid is what is called a **ruled surface**; that is, it can be generated by the motion of a straight line. In fact, this exercise shows that through each point on the hyperbolic paraboloid there are two generating lines. The only other quadric surfaces that are ruled surfaces are cylinders, cones, and hyperboloids of one sheet.)

Because (a, b, c) is on the hyperbolic paraboloid, $c = b^2 - a^2$.

$$(b+t)^2 - (a+t)^2 = b^2 + 2bt + t^2 - a^2 - 2at - t^2 = b^2 - a^2 + 2(b-a)t = c + 2(b-a)t$$

Therefore $(a + t, b + t, c + 2(b - a)t)$ is on the surface.

$$(b-t)^2 - (a+t)^2 = b^2 - 2bt + t^2 - a^2 - 2at - t^2 = b^2 - a^2 - 2(a+b)t = c - 2(a+b)t$$

So $(a + t, b - t, c - 2(a + b)t)$ is on the surface, too.

13.1.4 Find the limit

$$\lim_{t \rightarrow 1} \left(\frac{t^2 - t}{t - 1} \mathbf{i} + \sqrt{t + 8} \mathbf{j} + \frac{\sin \pi t}{\ln t} \mathbf{k} \right).$$

$$\lim_{t \rightarrow 1} \frac{t^2 - t}{t - 1} = \lim_{t \rightarrow 1} \frac{t(t - 1)}{t - 1} = \lim_{t \rightarrow 1} t = 1$$

$$\lim_{t \rightarrow 1} \sqrt{t + 8} = \sqrt{1 + 8} = 3$$

$$\lim_{t \rightarrow 1} \frac{\sin \pi t}{\ln t} = \lim_{t \rightarrow 1} \frac{\pi \cos \pi t}{\frac{1}{t}} = \lim_{t \rightarrow 1} \pi t \cos \pi t = -\pi$$

$$\lim_{t \rightarrow 1} \left(\frac{t^2 - t}{t - 1} \mathbf{i} + \sqrt{t + 8} \mathbf{j} + \frac{\sin \pi t}{\ln t} \mathbf{k} \right) = \mathbf{i} + 3\mathbf{j} - \pi \mathbf{k}$$

13.1.10 Sketch the curve

$$\mathbf{r}(t) = \langle \sin \pi t, t, \cos \pi t \rangle.$$

Indicate with an arrow the direction in which t increases.

The direction that t increases is the direction of tangent vector at each point.

$$\mathbf{r}'(t) = \langle \pi \cos t, 1, -\pi \sin \pi t \rangle$$

The y coefficient of $\mathbf{r}'(t)$ is positive.

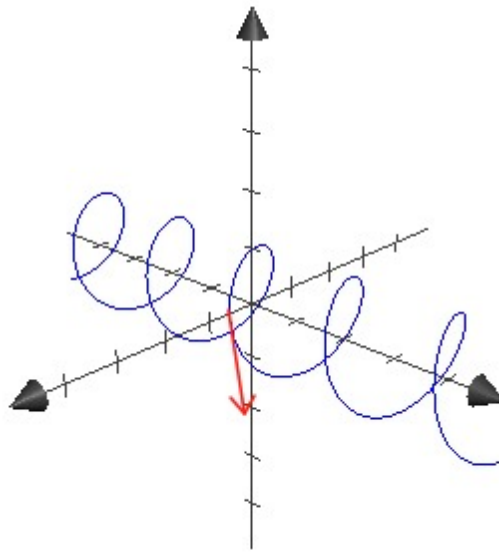

13.1.11 Sketch the curve

$$\mathbf{r}(t) = \langle 1, \cos t, 2 \sin t \rangle.$$

Indicate with an arrow the direction in which t increases.

The curve is an ellipse on the plane $x = 1$, because

$$y^2 + \frac{z^2}{2^2} = \cos^2 t + \left(\frac{2 \sin t}{2}\right)^2 = \cos^2 t + \sin^2 t = 1.$$

$$\mathbf{r}'(t) = \langle 0, -\sin t, 2 \cos t \rangle$$

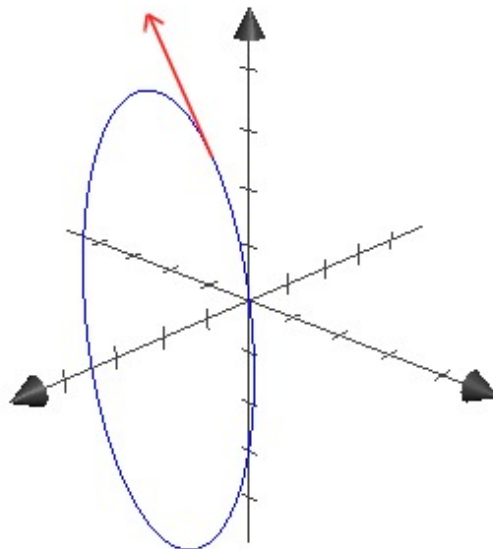

13.1.18 Find a vector equation and parametric equations for the line segment that joins $P(-1, 2, -2)$ to $Q(-3, 5, 1)$.

A point on the line: $P = (-1, 2, -2)$

A direction vector: $\overrightarrow{PQ} = \langle -3, 5, 1 \rangle - \langle -1, 2, -2 \rangle = \langle -2, 3, 3 \rangle$

The vector equation of the line:

$$\mathbf{r}(t) = \langle -1, 2, -2 \rangle + t\langle -2, 3, 3 \rangle = \langle -1 - 2t, 2 + 3t, -2 + 3t \rangle$$

$t = 0 \Rightarrow \langle -1, 2, -2 \rangle = P, t = 1 \Rightarrow \langle -2, 3, 3 \rangle = Q$

Equation of the line segment:

$$\mathbf{r}(t) = \langle -1 - 2t, 2 + 3t, -2 + 3t \rangle, \quad 0 \leq t \leq 1$$

Parametric equations:

$$x = -1 - 2t, y = 2 + 3t, z = -2 + 3t, \quad 0 \leq t \leq 1$$

13.1.27 Show that the curve with parametric equations $x = t \cos t, y = t \sin t, z = t$ lies on the cone $z^2 = x^2 + y^2$, and use this fact to help sketch the curve.

$$(t \cos t)^2 + (t \sin t)^2 = t^2 \cos^2 t + t^2 \sin^2 t = t^2(\cos^2 t + \sin^2 t) = t^2$$

It lies on $z^2 = x^2 + y^2$.

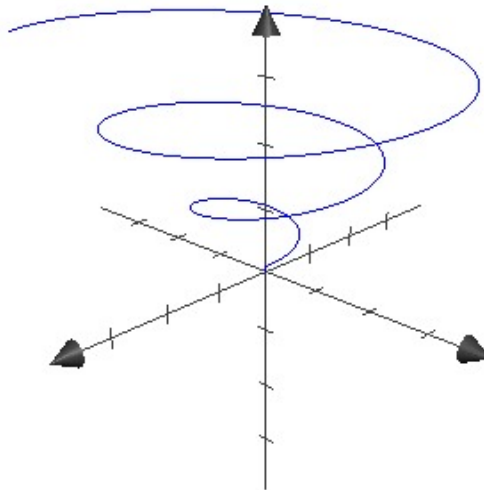

13.1.42 Find a vector function that represents the curve of intersection of the paraboloid $z = 4x^2 + y^2$ and the parabolic cylinder $y = x^2$.

$$y = x^2, z = 4x^2 + y^2 = 4x^2 + x^4$$

$$\Rightarrow \mathbf{r}(t) = \langle t, t^2, 4t^2 + t^4 \rangle$$

13.1.43 Find a vector function that represents the curve of intersection of the hyperboloid $z = x^2 - y^2$ and the cylinder $x^2 + y^2 = 1$.

Because $x^2 + y^2 = 1$, a good parameterization is $x = \cos t, y = \sin t$.

$$z = x^2 - y^2 = \cos^2 t - \sin^2 t = \cos 2t$$

$$\Rightarrow \mathbf{r}(t) = \langle \cos t, \sin t, \cos 2t \rangle$$

To cover the curve once, we need to restrict the domain as $0 \leq t \leq 2\pi$.

13.1.48 Two particles travel along the space curves

$$\mathbf{r}_1(t) = \langle t, t^2, t^3 \rangle, \quad \mathbf{r}_2(t) = \langle 1 + 2t, 1 + 6t, 1 + 14t \rangle.$$

Do the particles collide? Do their paths intersect?

$$t = 1 + 2t \Rightarrow t = -1$$

$$t^2 = 1 + 6t \Rightarrow t^2 - 6t - 1 = 0 \Rightarrow t = \frac{6 \pm \sqrt{6^2 + 4}}{2} = 3 \pm \sqrt{10}$$

There is no common solution of $\mathbf{r}_1(t) = \mathbf{r}_2(t)$. They don't collide.

$$\mathbf{r}_1(t) = \mathbf{r}_2(s) \Rightarrow t = 1 + 2s, t^2 = 1 + 6s, t^3 = 1 + 14s$$

$$\Rightarrow t - 1 = 2s, t^2 - 1 = 6s \Rightarrow t^2 - 1 = 3(t - 1) \Rightarrow t^2 - 1 - 3t + 3 = 0$$

$$\Rightarrow t^2 - 3t + 2 = 0 \Rightarrow (t - 1)(t - 2) = 0 \Rightarrow t = 1 \text{ or } t = 2$$

$$t = 1 \Rightarrow s = 0$$

$$\mathbf{r}_1(1) = \langle 1, 1, 1 \rangle = \mathbf{r}_2(0)$$

So two curves intersect at $\langle 1, 1, 1 \rangle$.