

GEOLOGY IN ENGINEERING

Introduction

Engg works impose one / more engg processes on ground:

1. **LOAD** the ground – *weight of Dam*

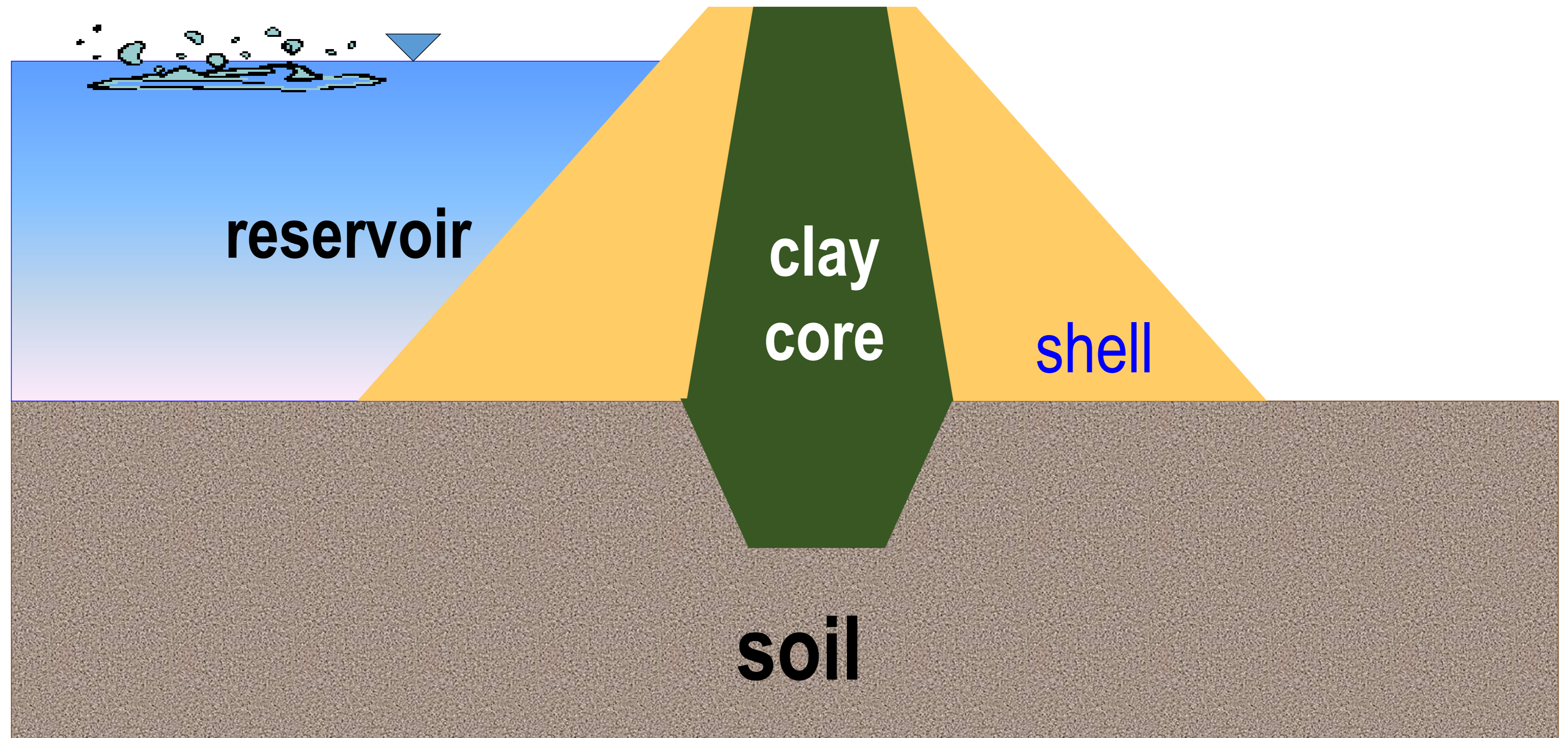

Introduction.....contd.

Typical ground reaction, for static loading may include:

- ELASTIC deformation, leading to SETTLEMENT of load-imposing structure
 - FAILURE in SHEAR of ground if foundation pressure exceeds load-carrying capacity of ground.
-

Introduction.....contd.

2. **WITHDRAW** support from ground (*surface excavation*) – may cause ground around it to lose support because of removed material, and may result in:

- **DEFORMATION of excavated slope**
- **UPWARDS heave of floor of excavation**

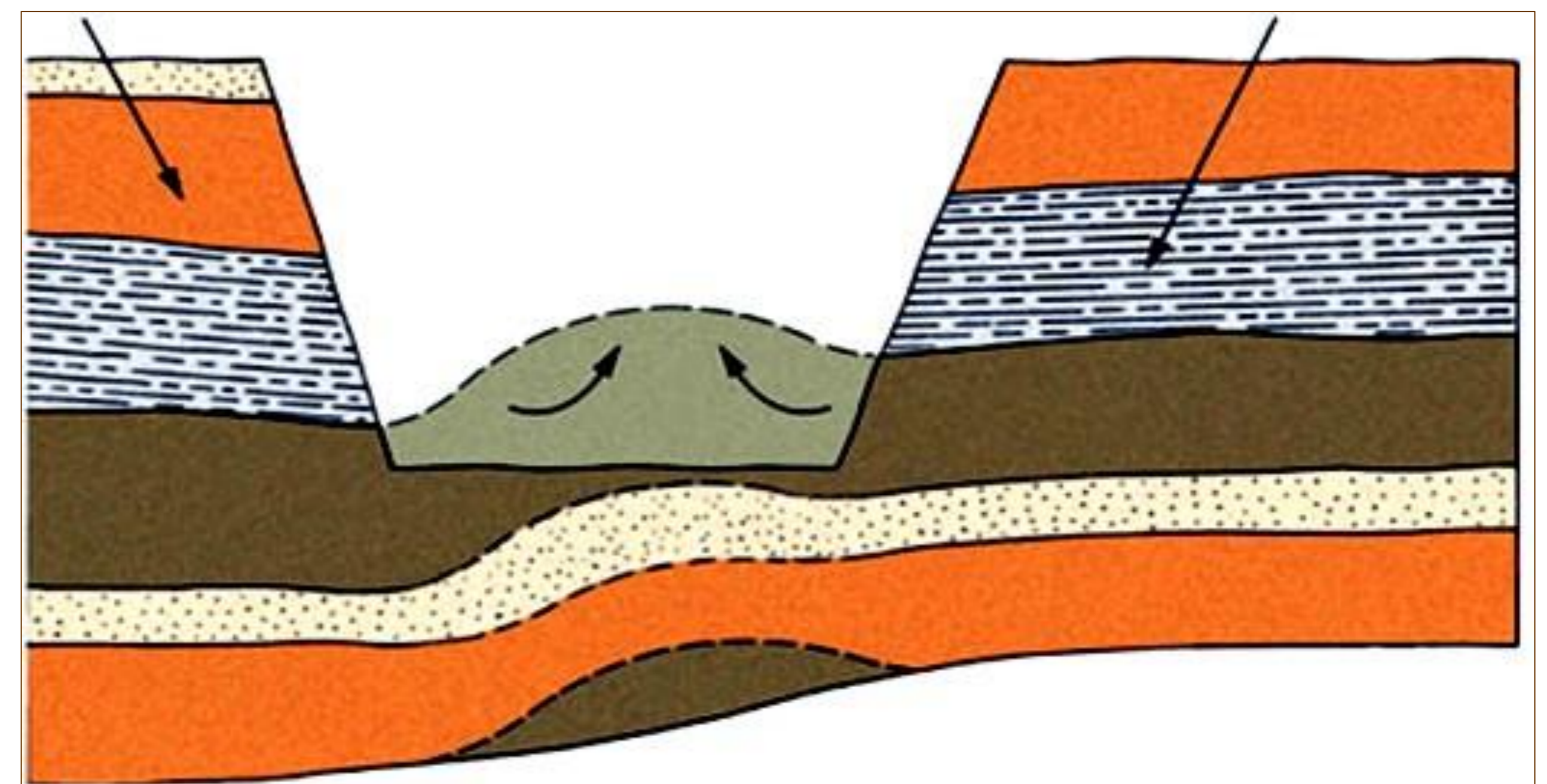
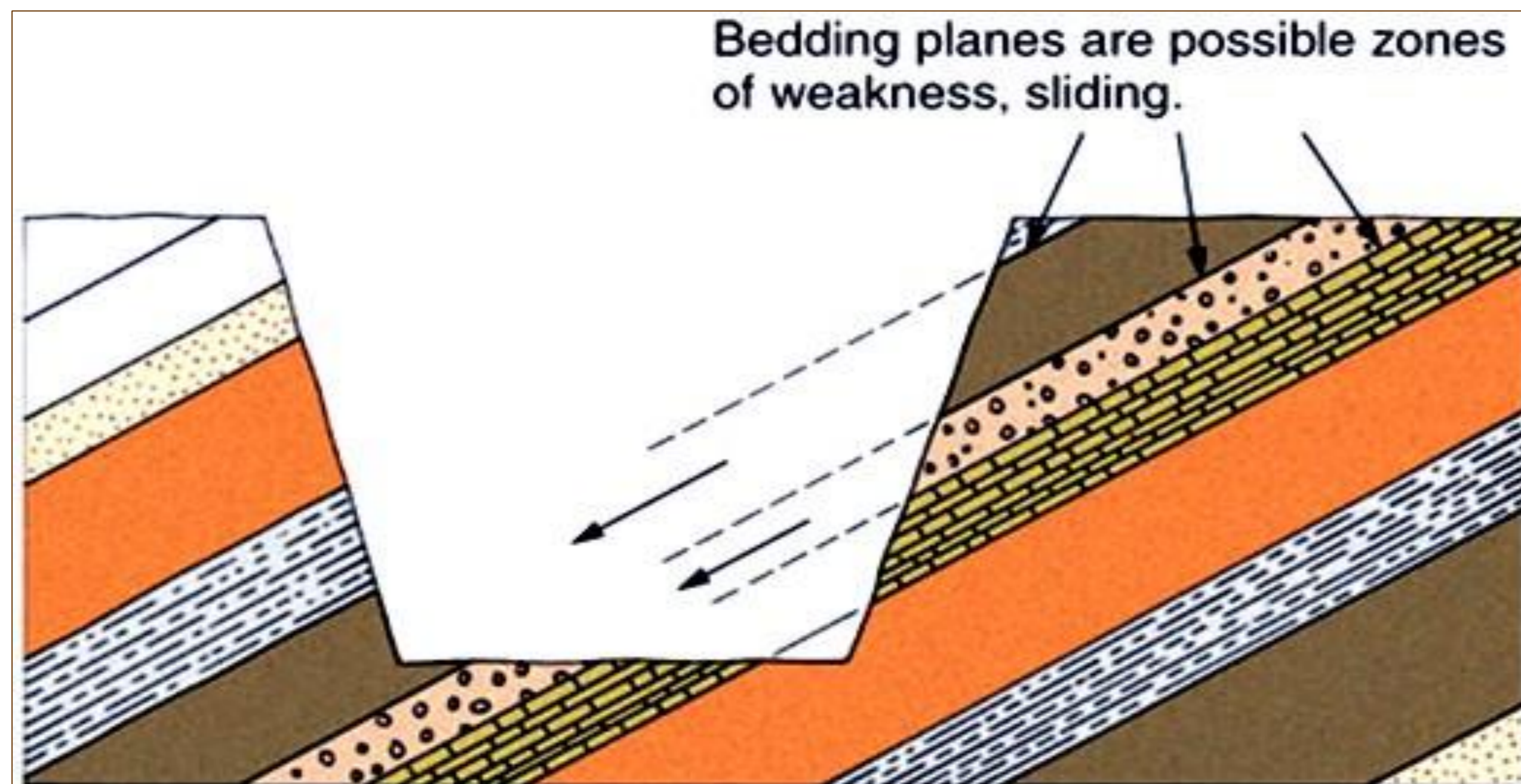

Introduction.....contd.

3. **CHANGE** fluid pressures in the ground – *pumping water from well.*

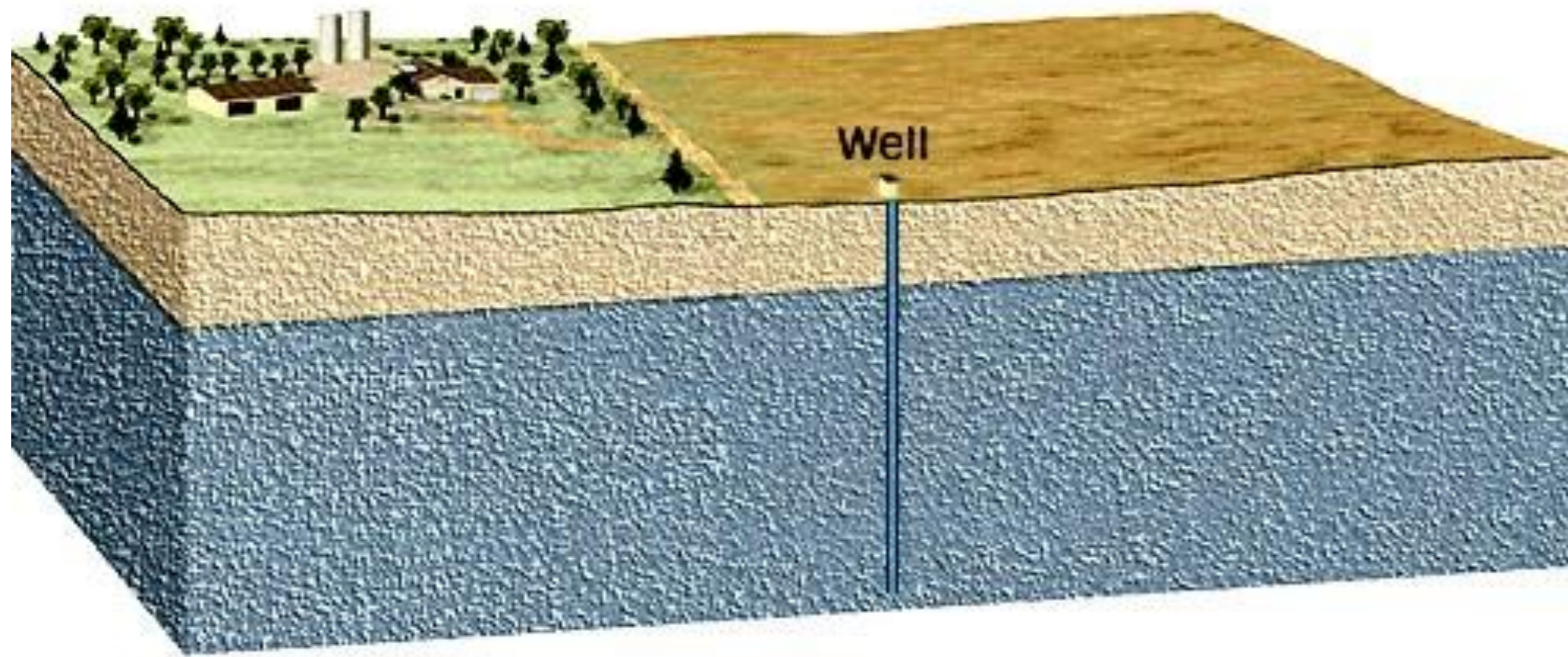

Groundwater table at rest.

Removal of pore water pressure by pumping water out results in consolidation of previously satd. Mats.

This may result in **SURFACE SUBSIDENCE**. Pumping fluids into ground already under stress may induce **SEISMICITY**.

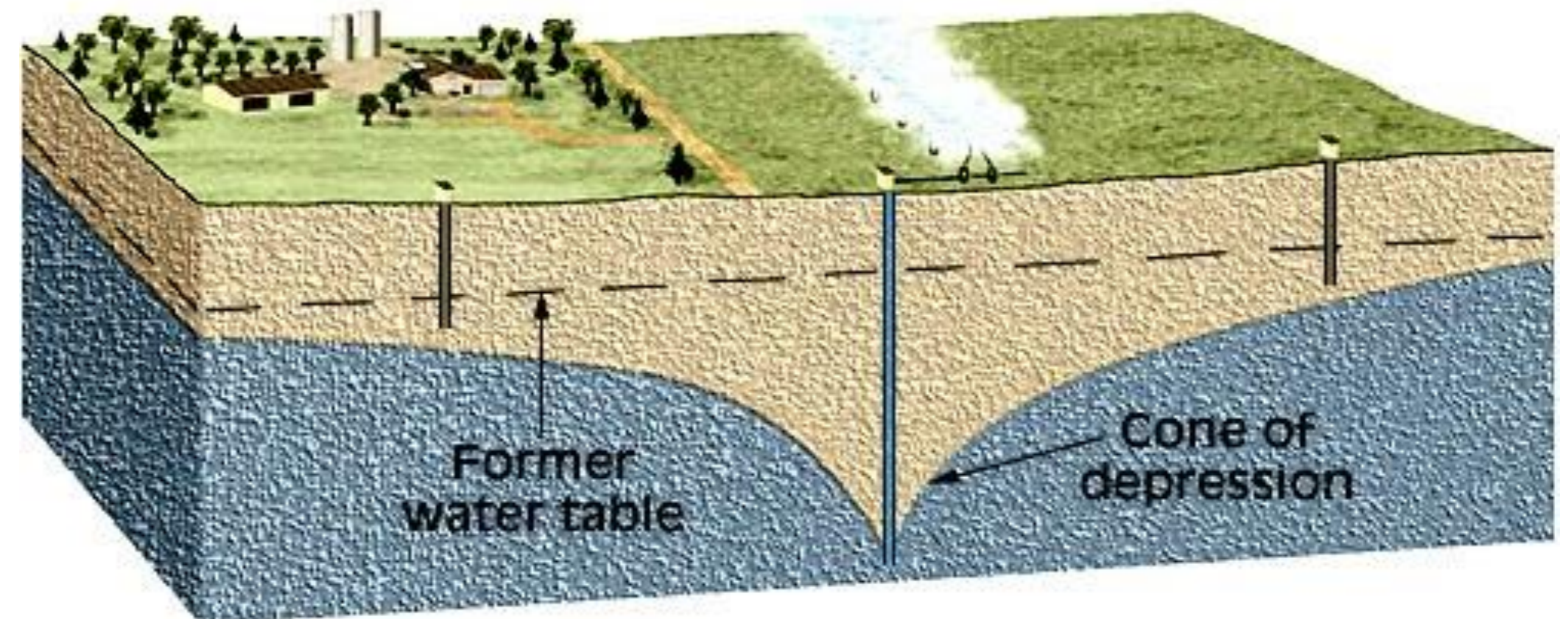

Introduction.....contd.

Response to each process requires:

- Knowledge of material properties
- Mass Fabric / mass properties

...to calculate **MAGNITUDE** & **NATURE** of response –
REACTION.

In this lecture, we shall deal with two engineering processes:

- Loading the ground, and
 - Withdrawal of support from the ground by surface excavations
-

Discontinuities in Surface Excavations

Introduction

*If support to the ground is withdrawn by surface excavation – e.g. by opening up of quarry for construction materials, a **slope results**.*

Such excavation can result from natural processes undertaken by:

- **Natural agencies** – *river erosion, coastal erosion*
- **Man-made processes** – *excavation for railways, roads, canals*

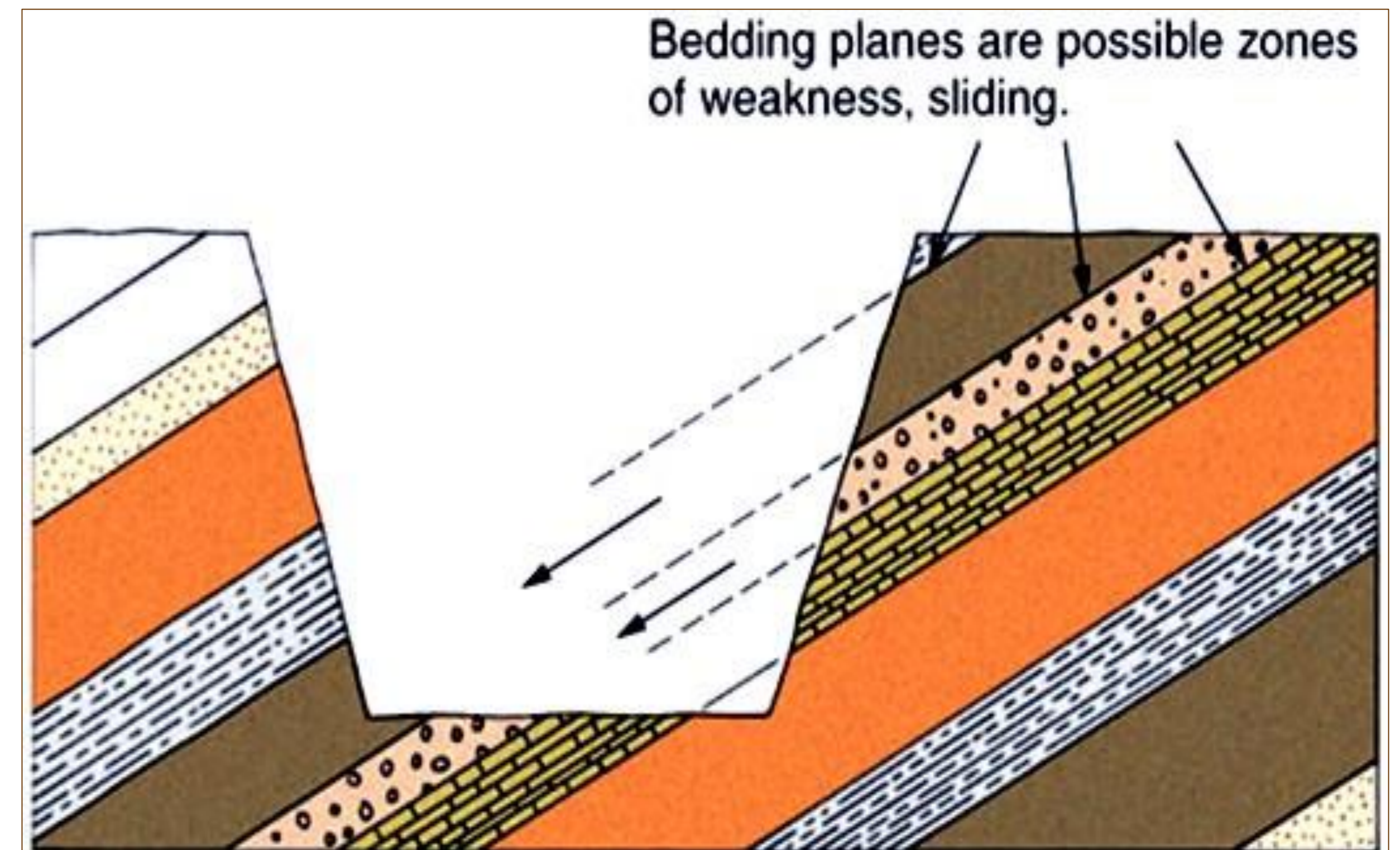

Factors that Influence stability of Slope

Surface excavations leave slopes whose stability is related to:

- 1. Slope angle*
- 2. Strength of materials and discontinuities in the slope*
- 3. Groundwater situation*

If slope formed is too steep to be supported by ground in sides of excavation, then slope will fail.

Factors that Influence stability of Slope.....contd.

1. Slope angle of material

- steepness of slope influences stability of its rock/soil masses in slope:
- *steepness of a pile of loose material such as sand has a distinct limit – **angle of repose***
- *Once angle of repose is reached, addition of more sand will make the pile broader but not taller*

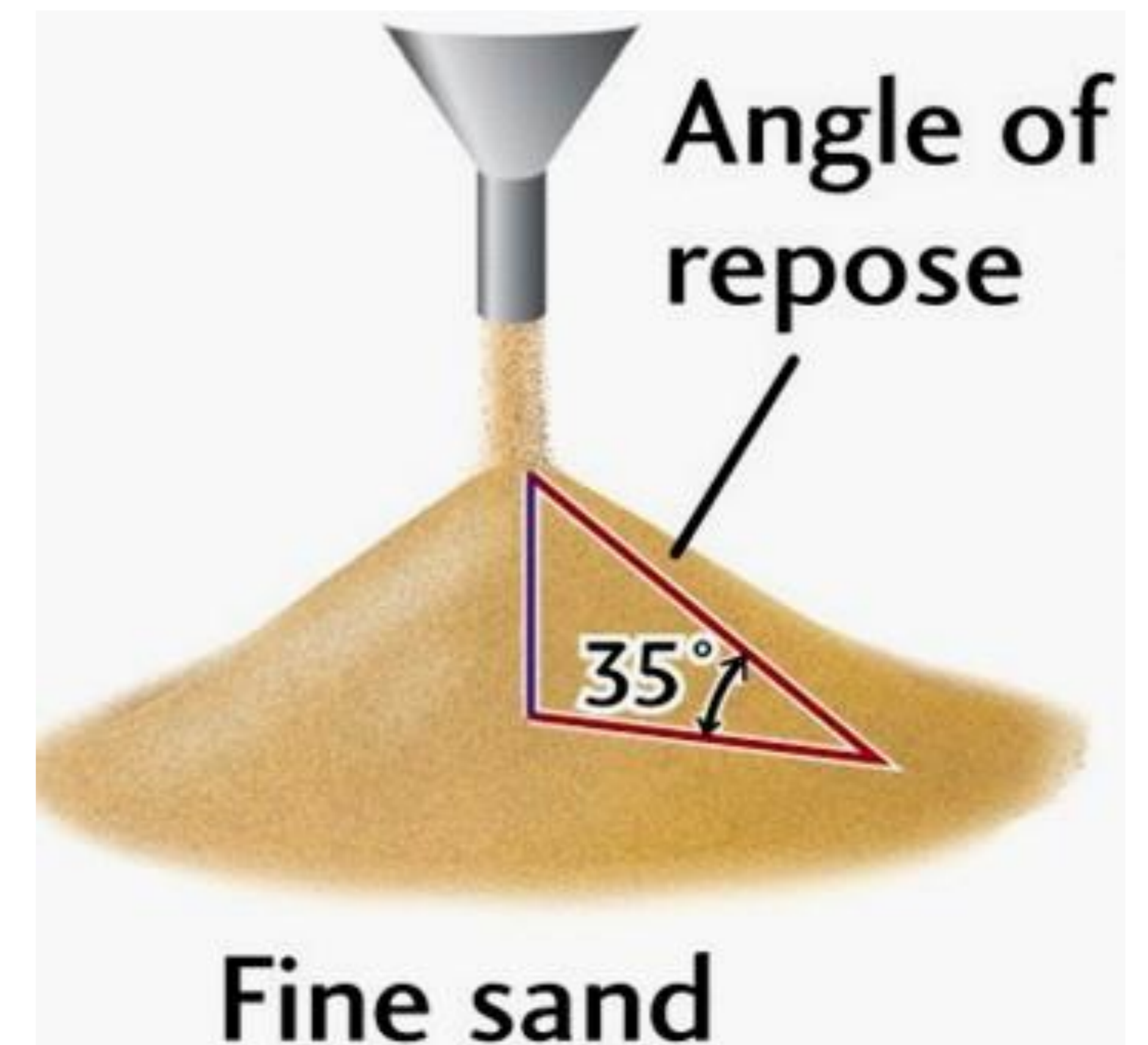

Factors that Influence stability of Slope.....contd.

Stability of slope also depends upon:

2) Nature of material in slope & its water content

➤ **and thus, its steepness.**

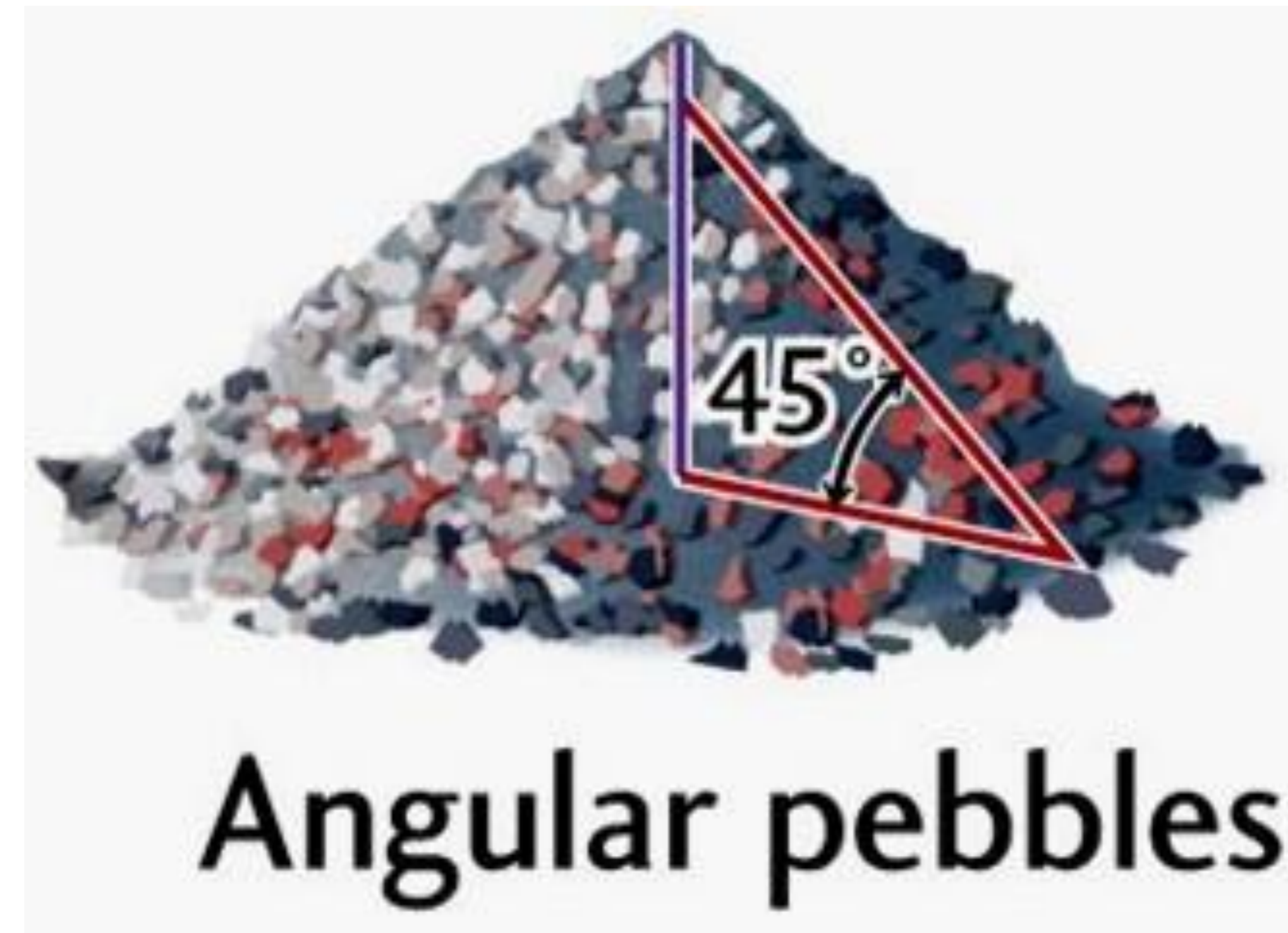
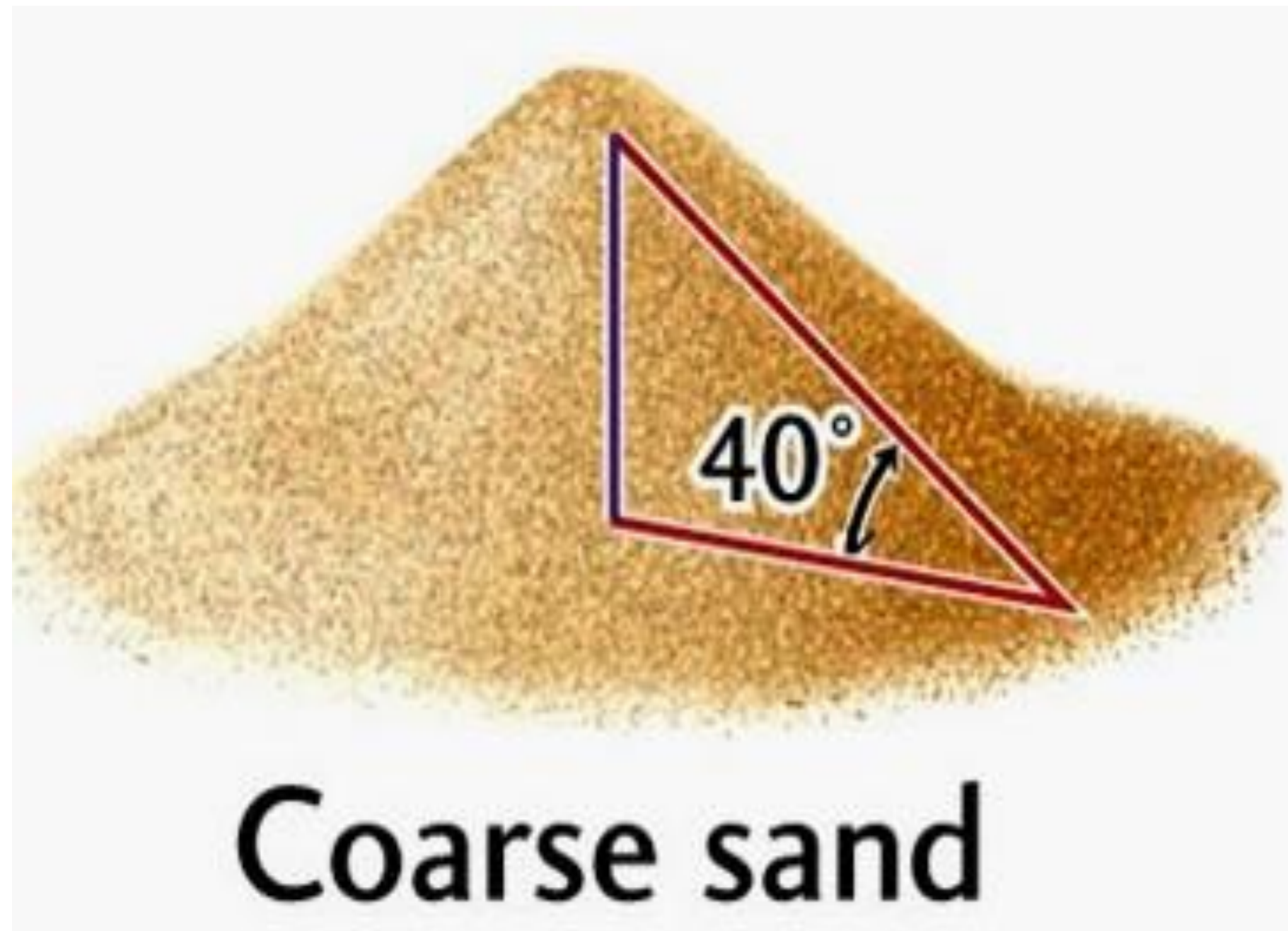

Factors that Influence stability of Slope.....contd.

3. Material's internal friction – total resistance to movement

- **consolidated dry materials** are held together by **cohesion** (attraction of like particles), **adhesion** (attraction of unlike particles) and **cementation.**

Factors that Influence stability of Slope.....contd.

c) Material's moisture content

- too little limits vegetation
- too much can push grains apart, add weight, or provide lubrication.



Types of Slope Failures

Classification based upon:

- **Nature of the material** (un/consolidated)
 - **Speed of movement**
 - **Nature of movement** (sliding, falling, or flowing)
-

Types of Slope Failures.....contd.

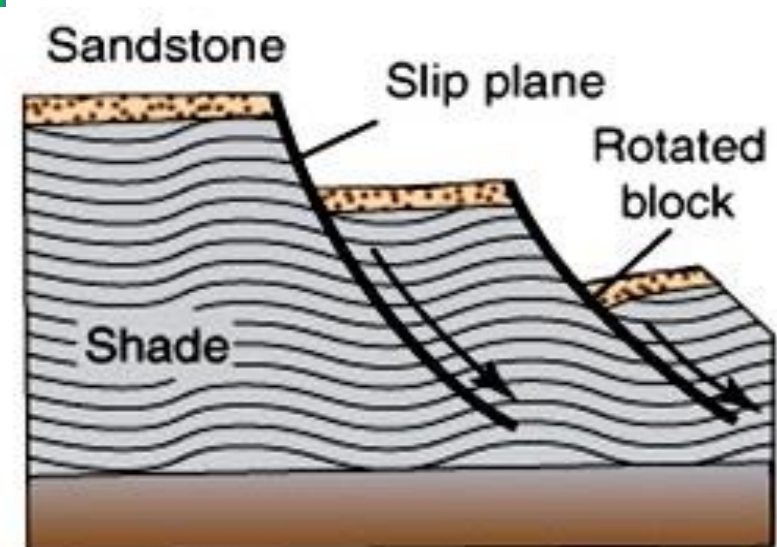

(a) Rock slump

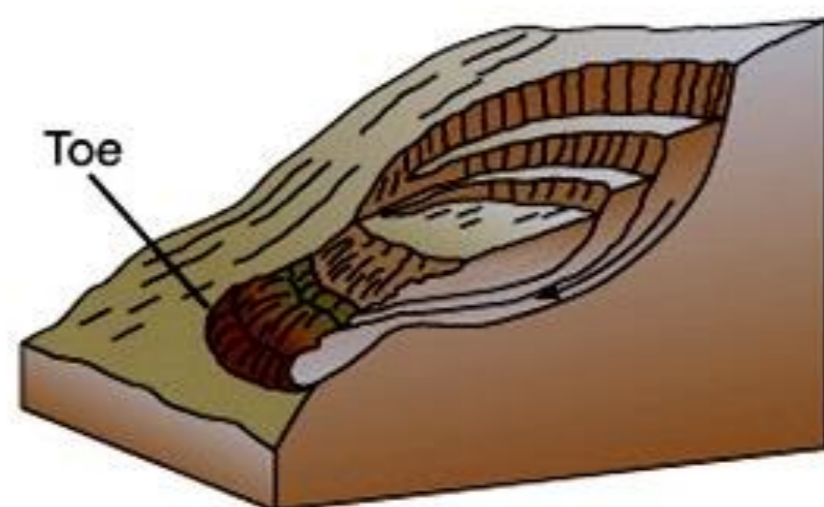

(b) Soil slump

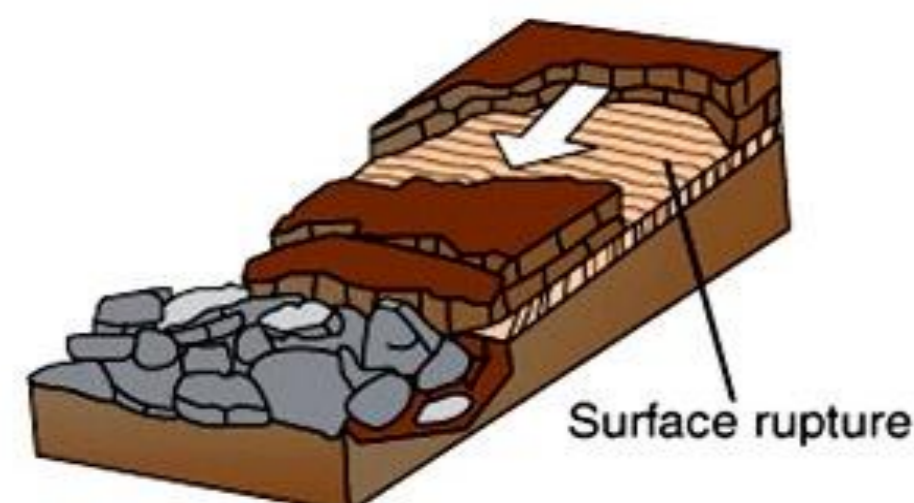

(c) Rock slide

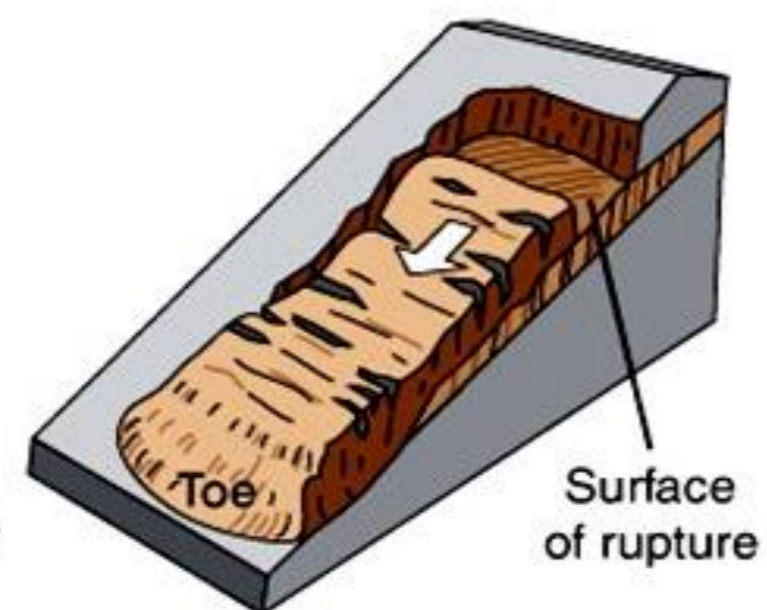

(d) Soil slide



(e) Rockfall

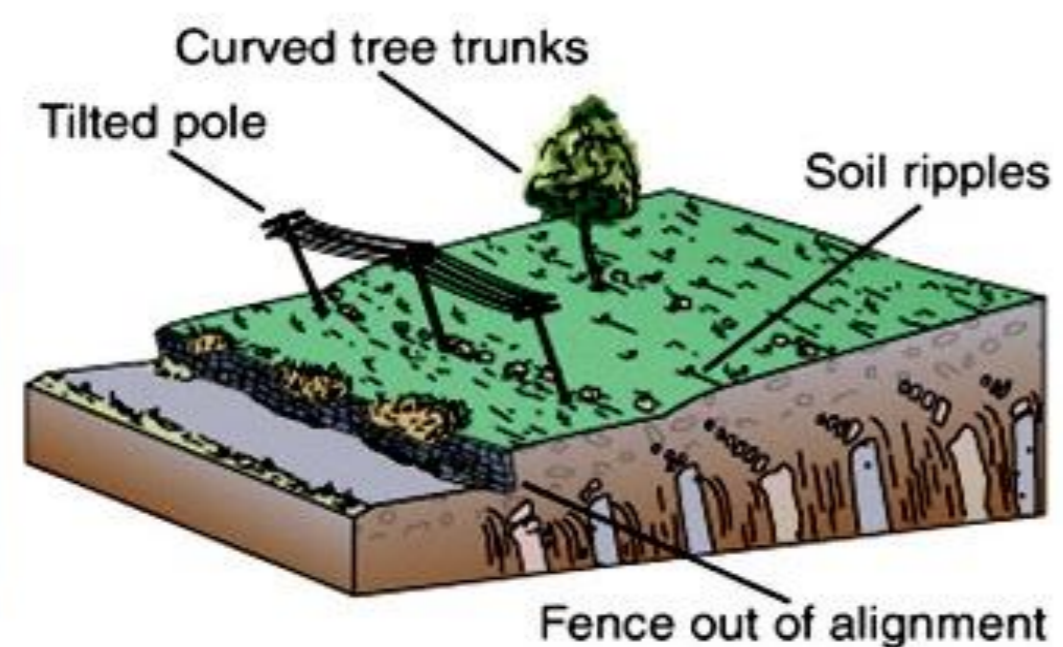

(f) Soil creep

Type of Movement	Materials	
	Rock	Soil
Landslides with variable water content and rate of movement	Rotational	
	Slump(a)	Slump(b)
	Translational	
	Rock slide(c)	Soil slide (slip)(d)
Falls	Rock fall(e)	Soil fall
Flows	Rock creep	Soil creep(f)
	Unconsolidated rock and soil (saturated)	
	Earth flow(g)	
	Debris flow / mud flow(h)	
	Debris avalanche(i)	
Lateral spread	Rock(j)	Soil
Subsidence	Rock(k)	Soil
Complex	Combination of slides, slumps, and flows(l)	

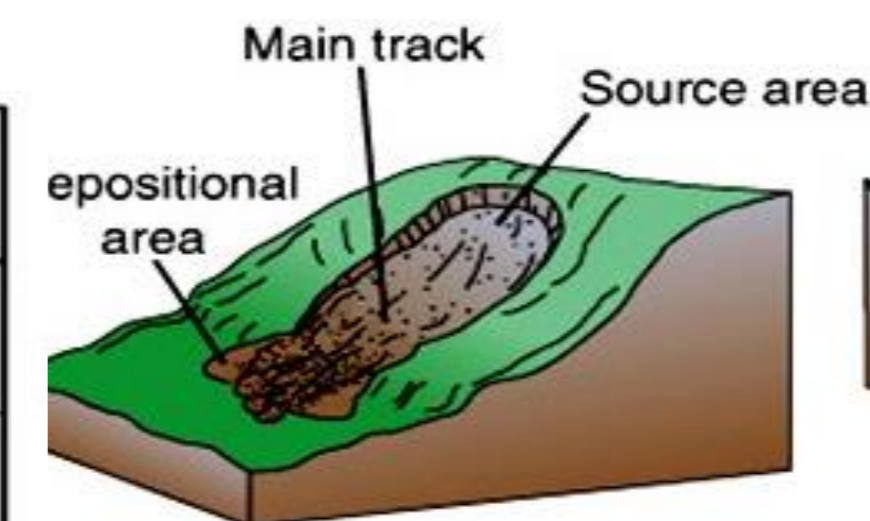

(g) Earthflow

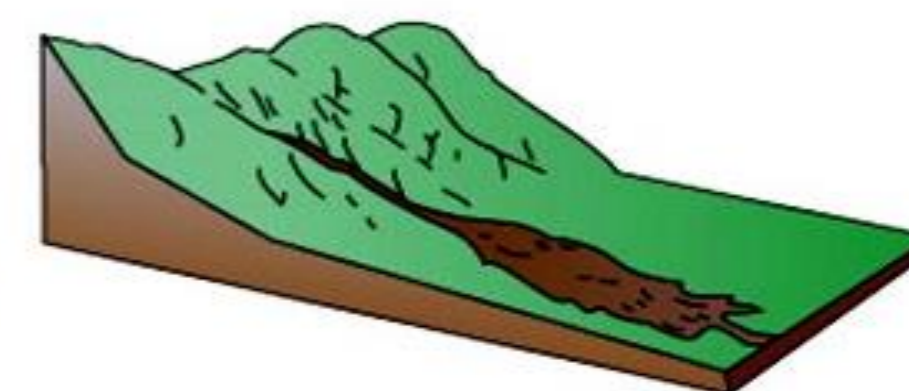

(h) Debris flow

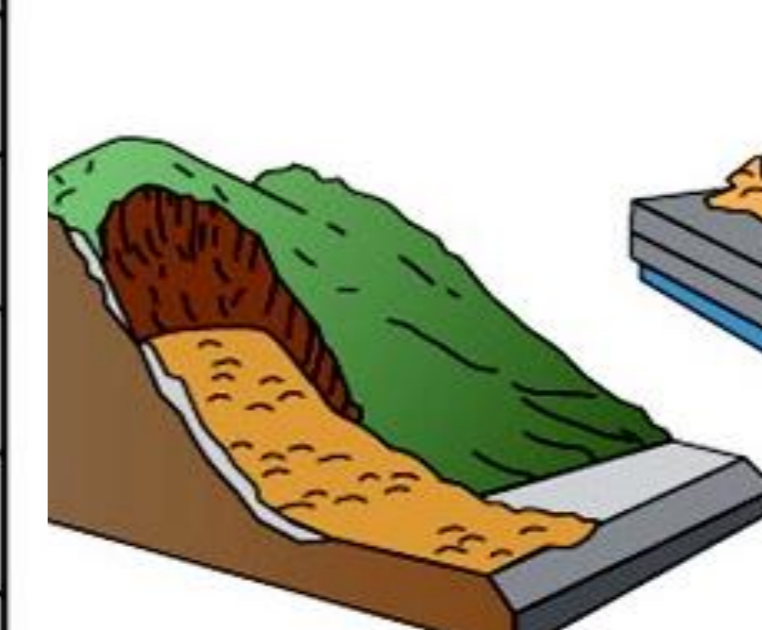

(i) Debris avalanche

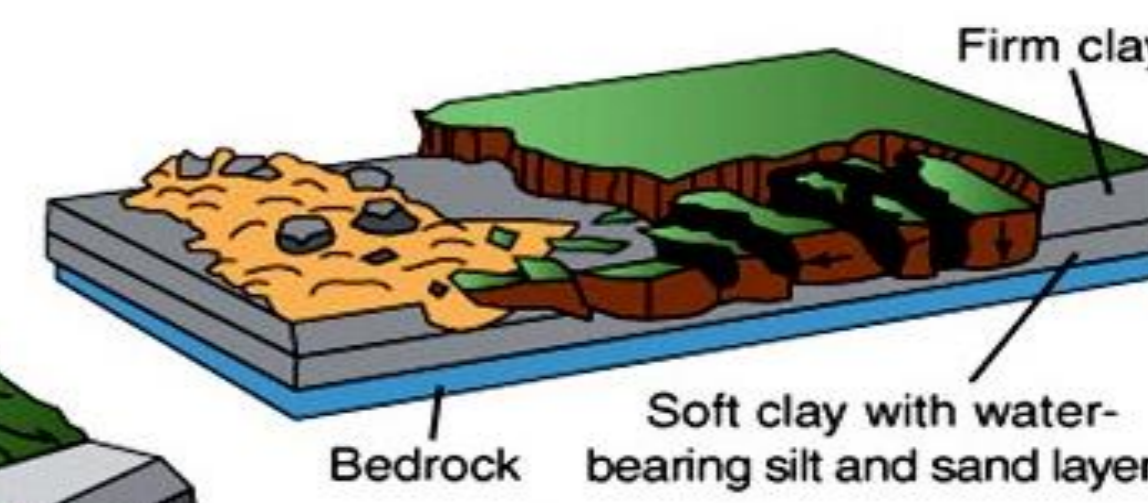

(j) Lateral spread



(k) Subsidence

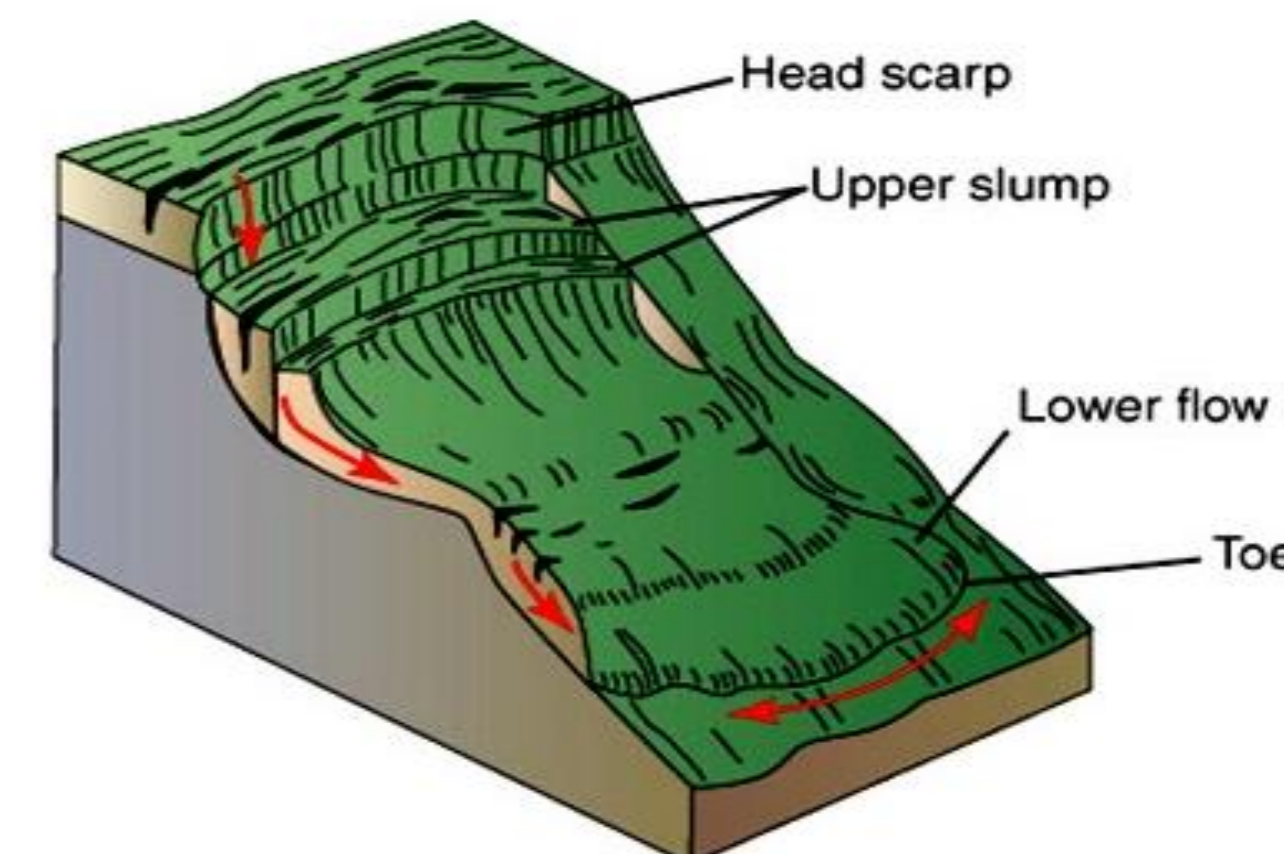

(l) Complex slide

Types of Slope Failures.....contd.

1. Nature of Material – Failure in CONSOLIDATED (Rock) Masses

a) Rockfall – free fall of boulders from a cliff

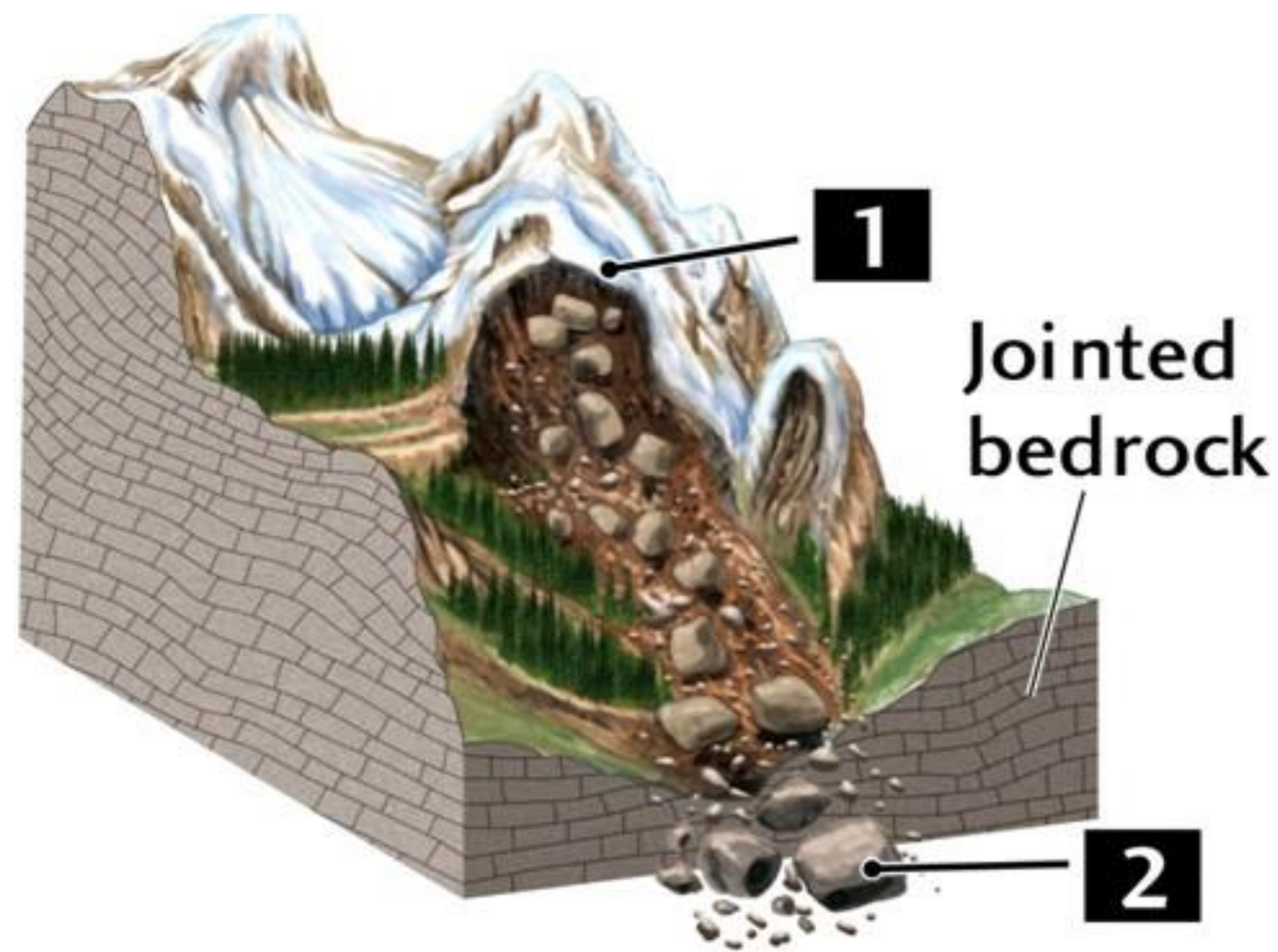

Types of Slope Failures.....contd.

- b) Rockslides** – sliding of rock down an incline usually due to **rock breaking** from its host material along **bedding plane, joint, or other structural weakness.**

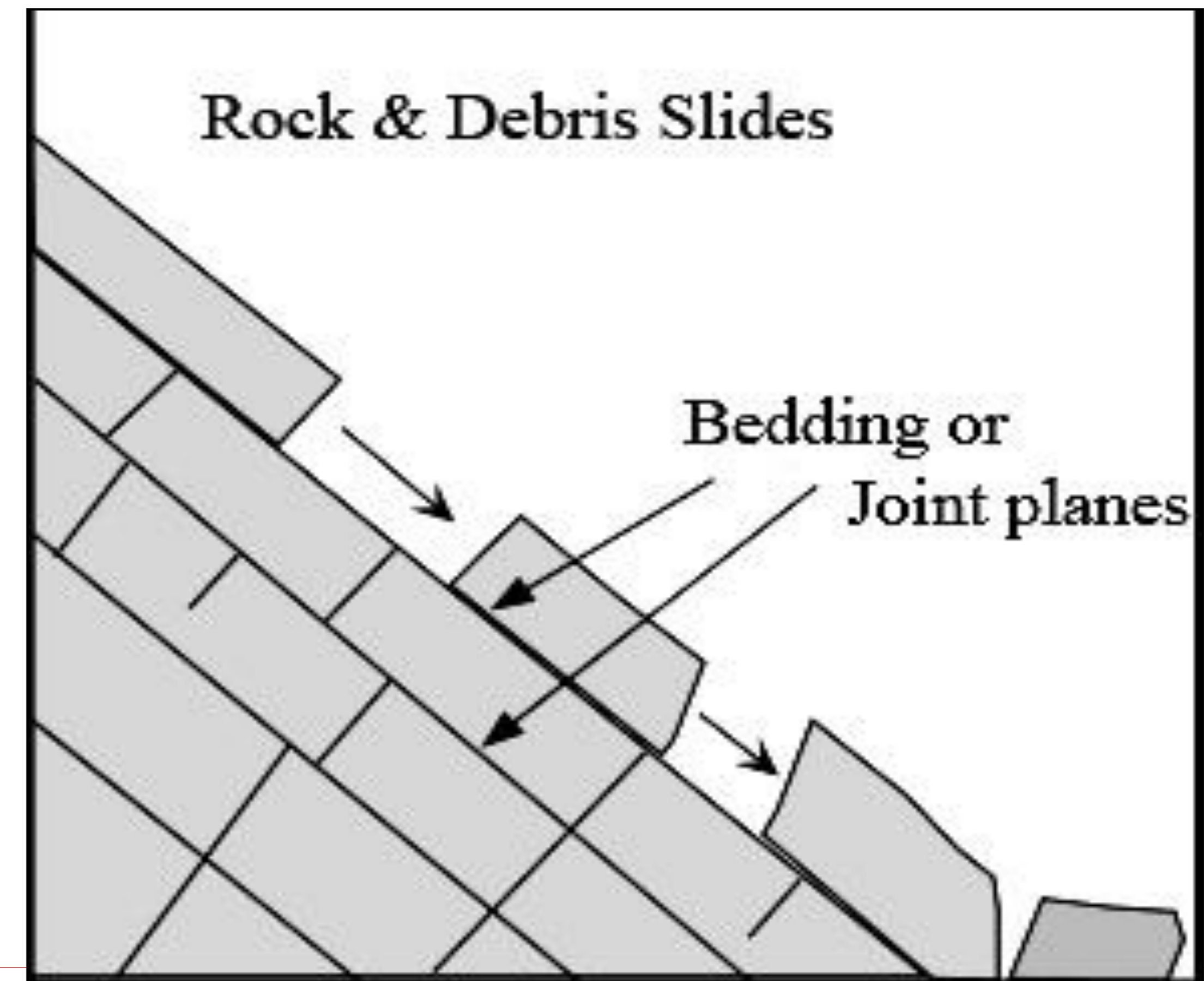
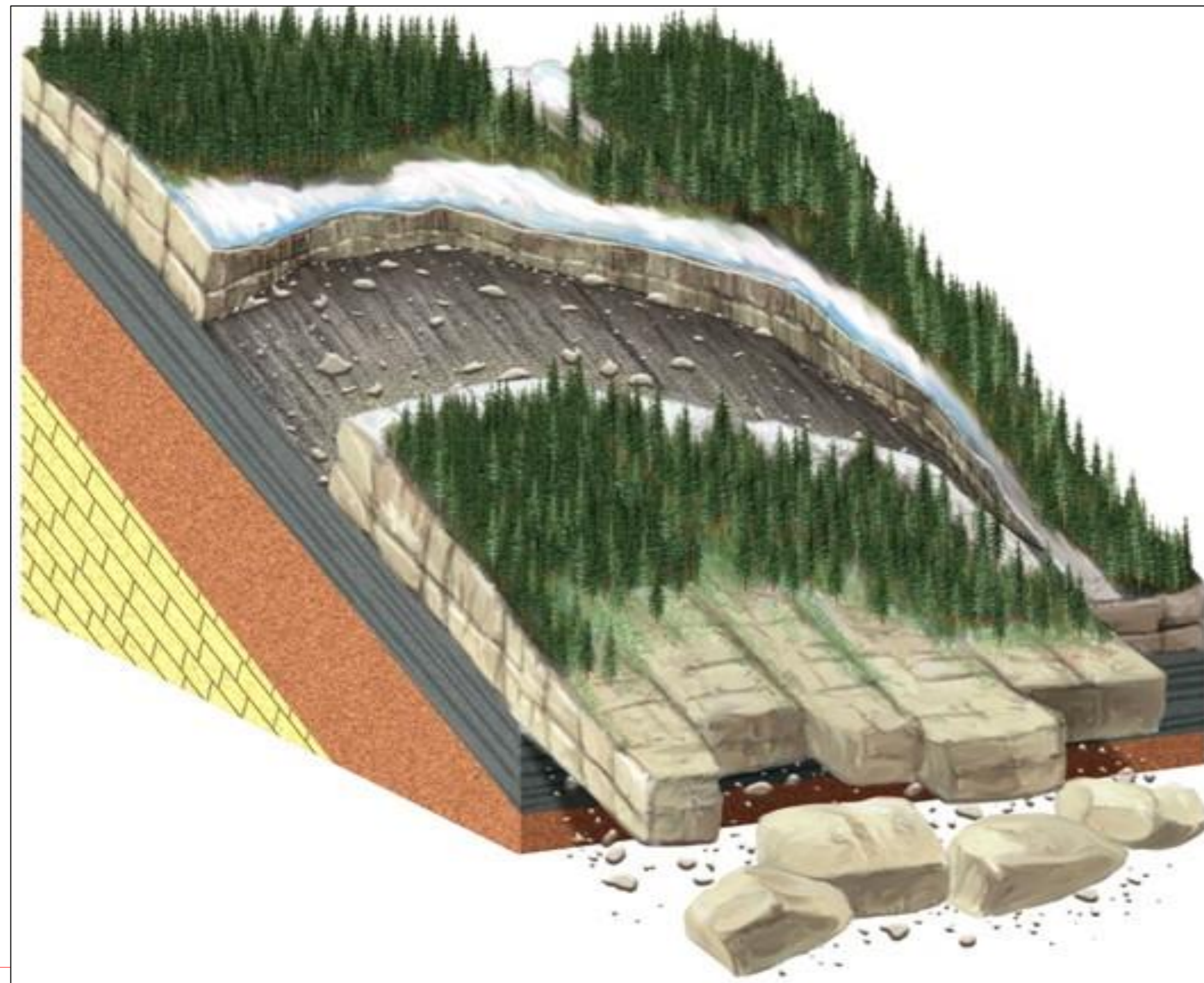

Types of Slope Failures.....contd.

2. Failure in Unconsolidated ("Soil") Masses

a) Creep – extremely slow, almost imperceptible downslope movement of soil and rock debris.

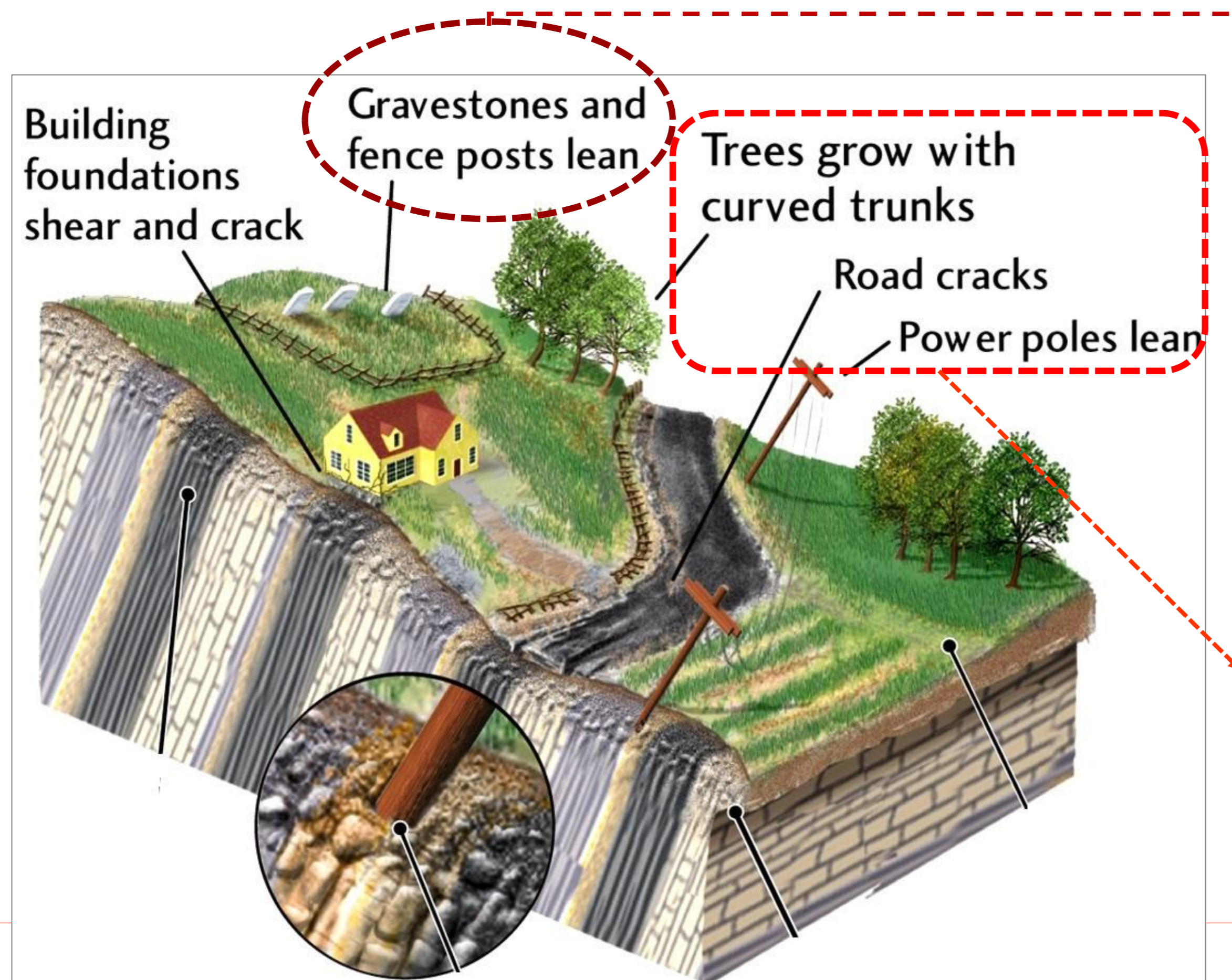

Types of Slope Failures.....contd.

b) Earth flows and Debris flows – consist of mixtures of rock fragments, mud & water that flow downslope as viscous fluids; **avalanches** – the fastest unconsolidated failure on steep slopes in humid areas

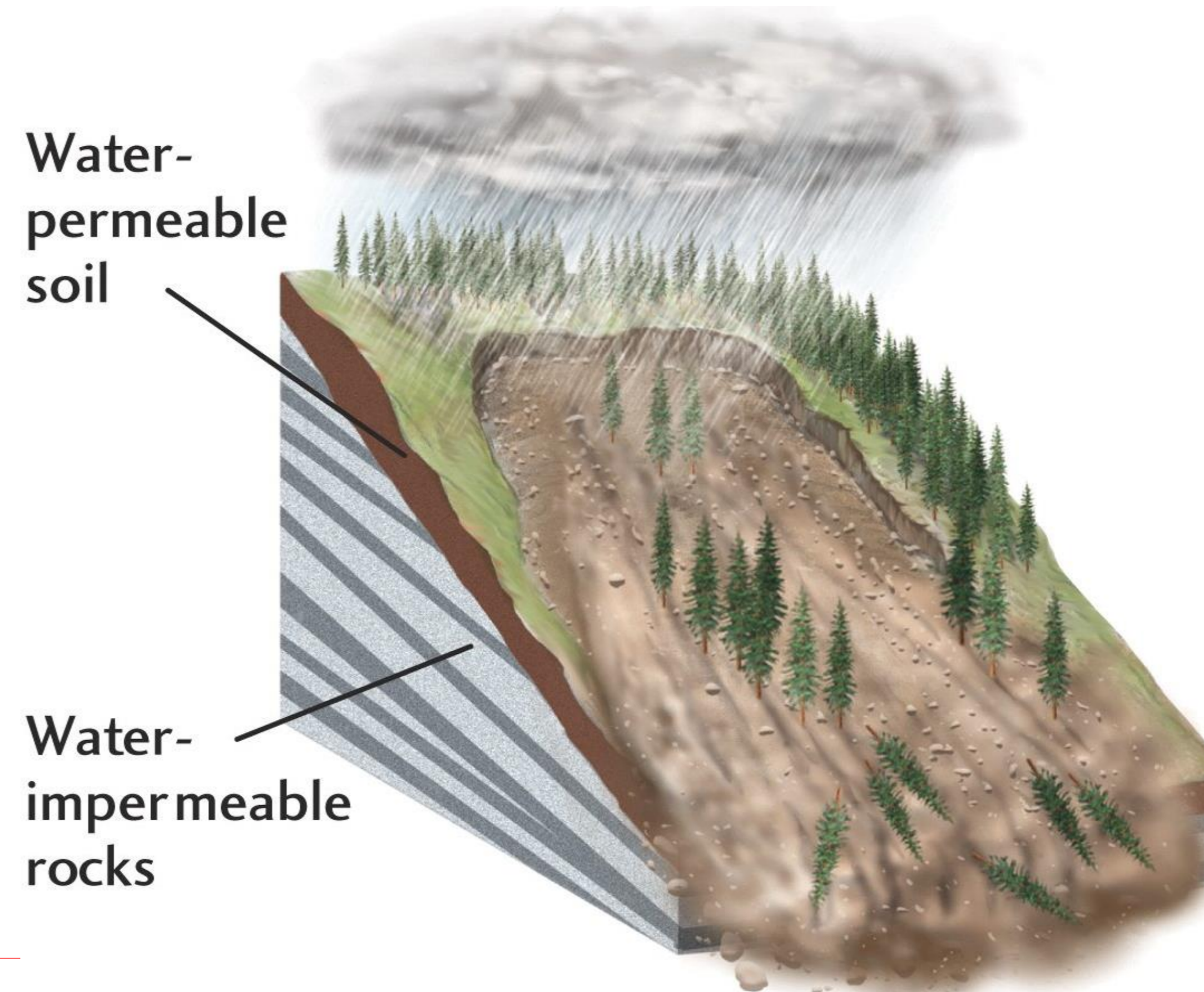

video

Types of Slope Failures.....contd.

c) Mudflows – a variety of debris flow that consist mostly of small silt and clay-sized particles

- Usually occur after heavy rain
- Have as much as 30% water content

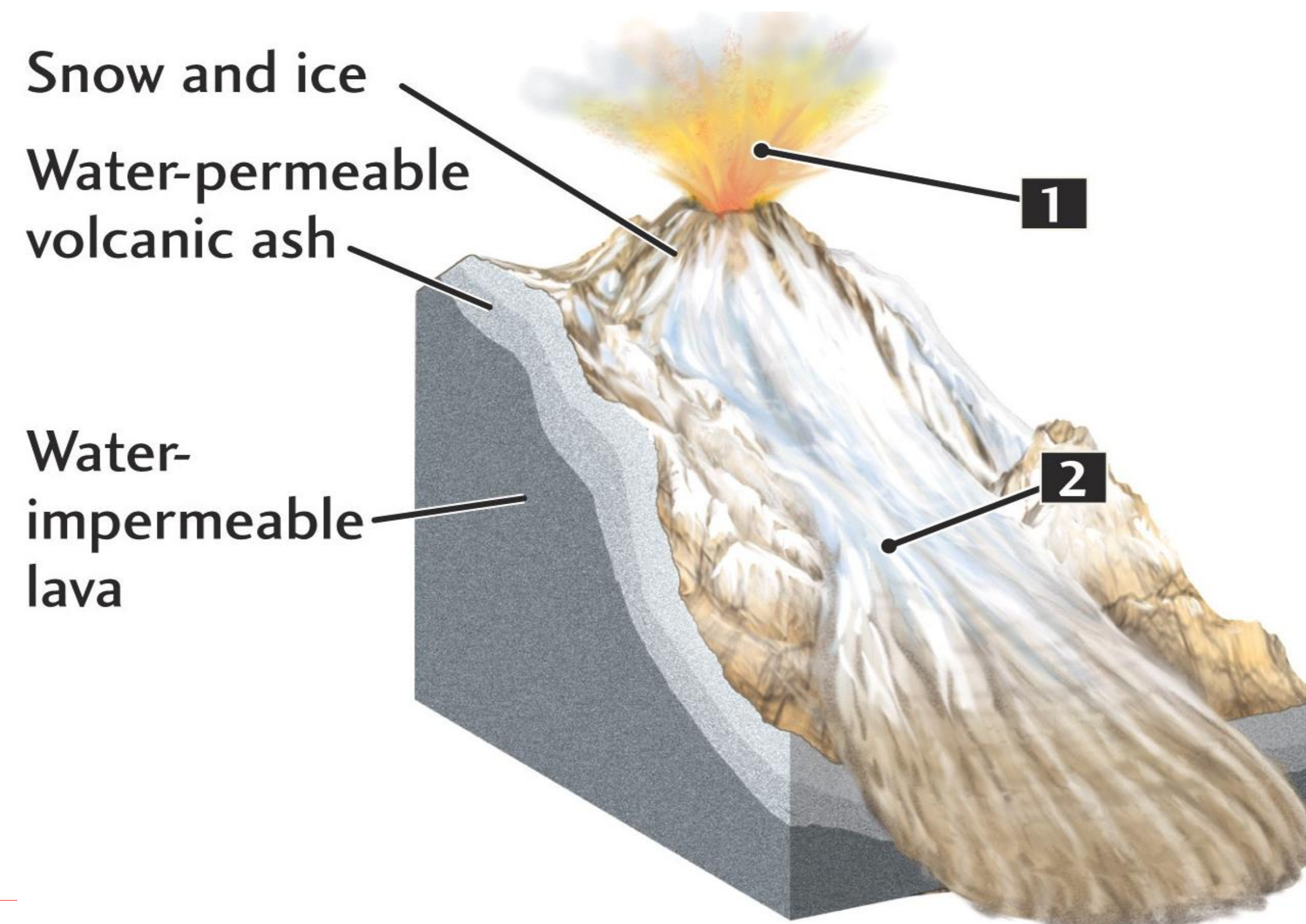

Types of Slope Failures – Summary

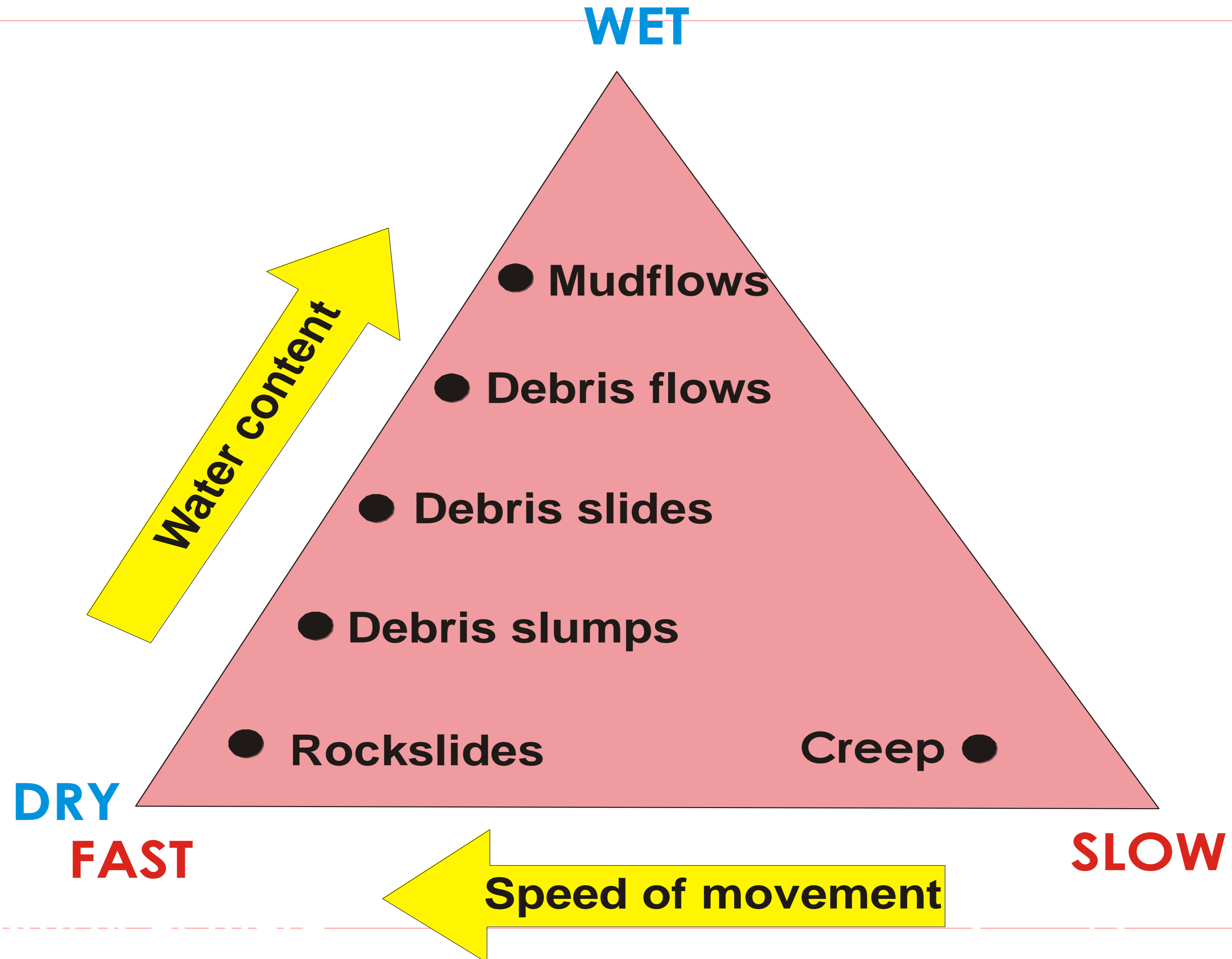

Sliding due to Gravitational Loading

1. Gravitational Force

Force that acts everywhere on the Earth's surface, pulling everything in a direction toward the centre of the Earth.

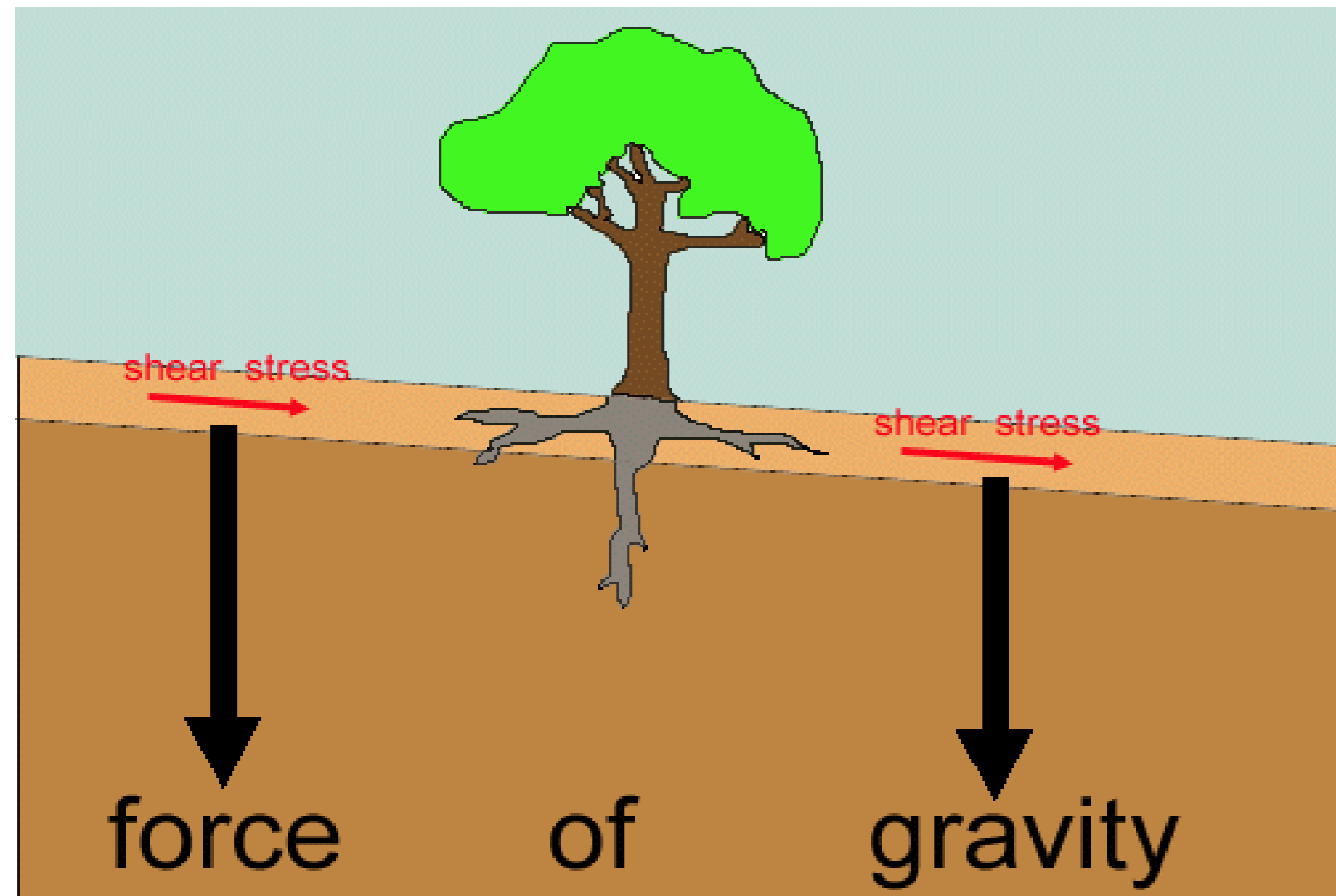

Mass wasting is unlikely on this slope because little shear stress is being produced by gravity.

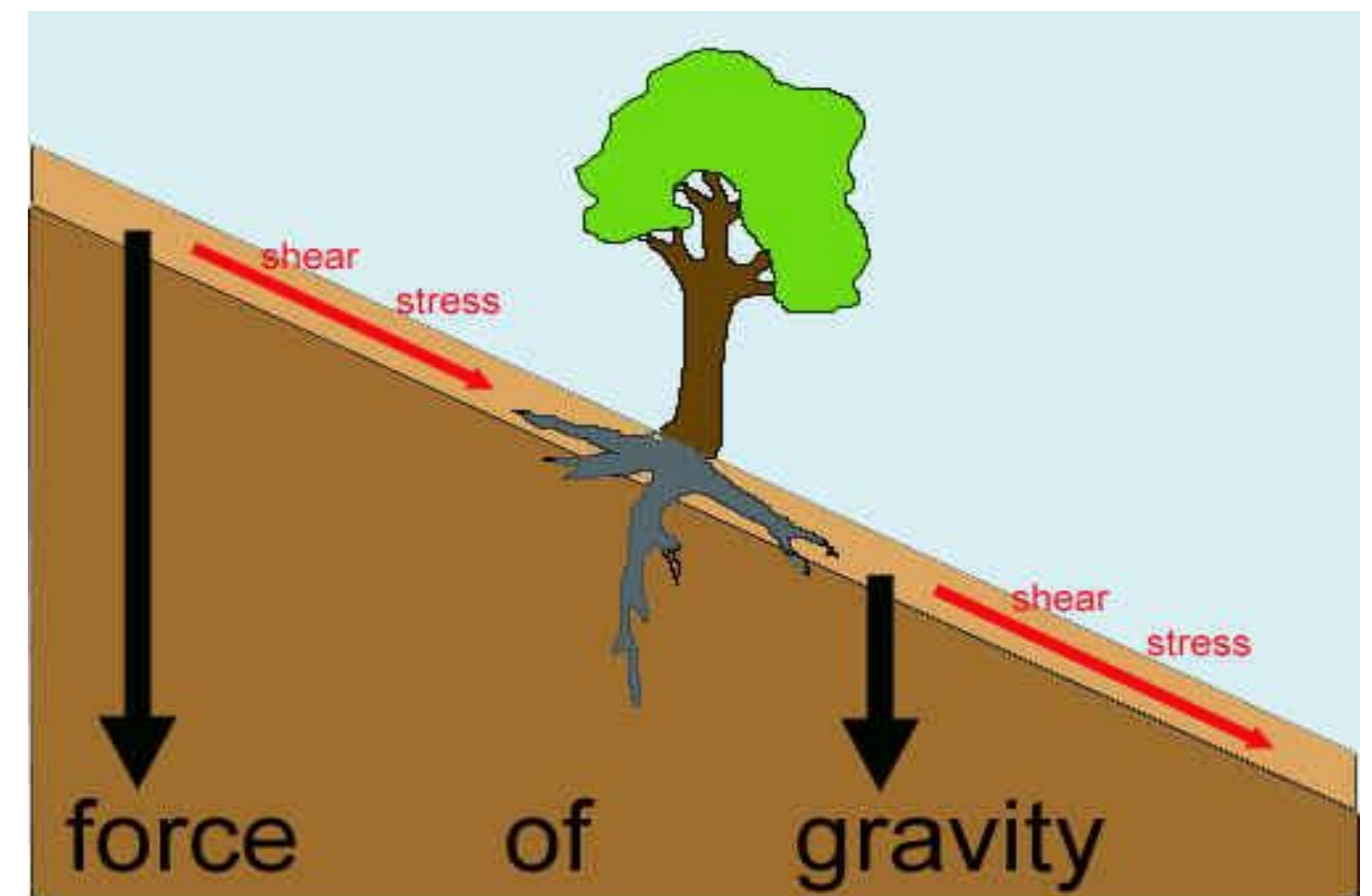

Mass wasting is much more likely on the slope because more shear stress is being produced

Sliding due to Gravitational Loading.....contd.

2. Concept

Gravity – Force that acts everywhere on the Earth's surface, pulling everything in a direction toward the centre of the Earth.

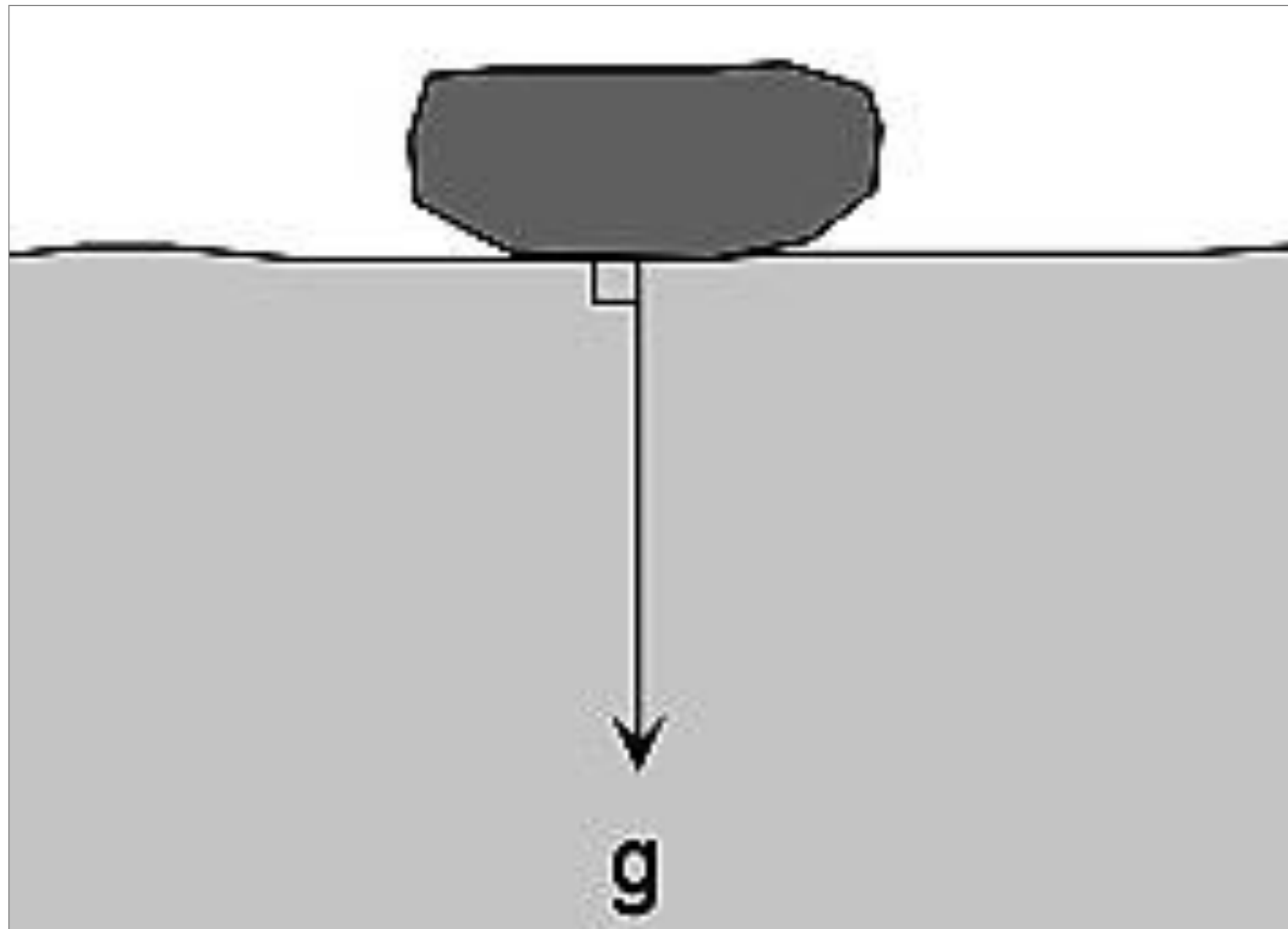

On a flat surface, parallel to the Earth's surface, the force of gravity acts downward.

So, long as material remains on flat surface, it will NOT move under force of gravity.

Sliding due to Gravitational Loading.....contd.

On slope, force of gravity can be resolved into two components:

- *A component acting perpendicular to slope, and*
- *A component acting tangential to slope.*

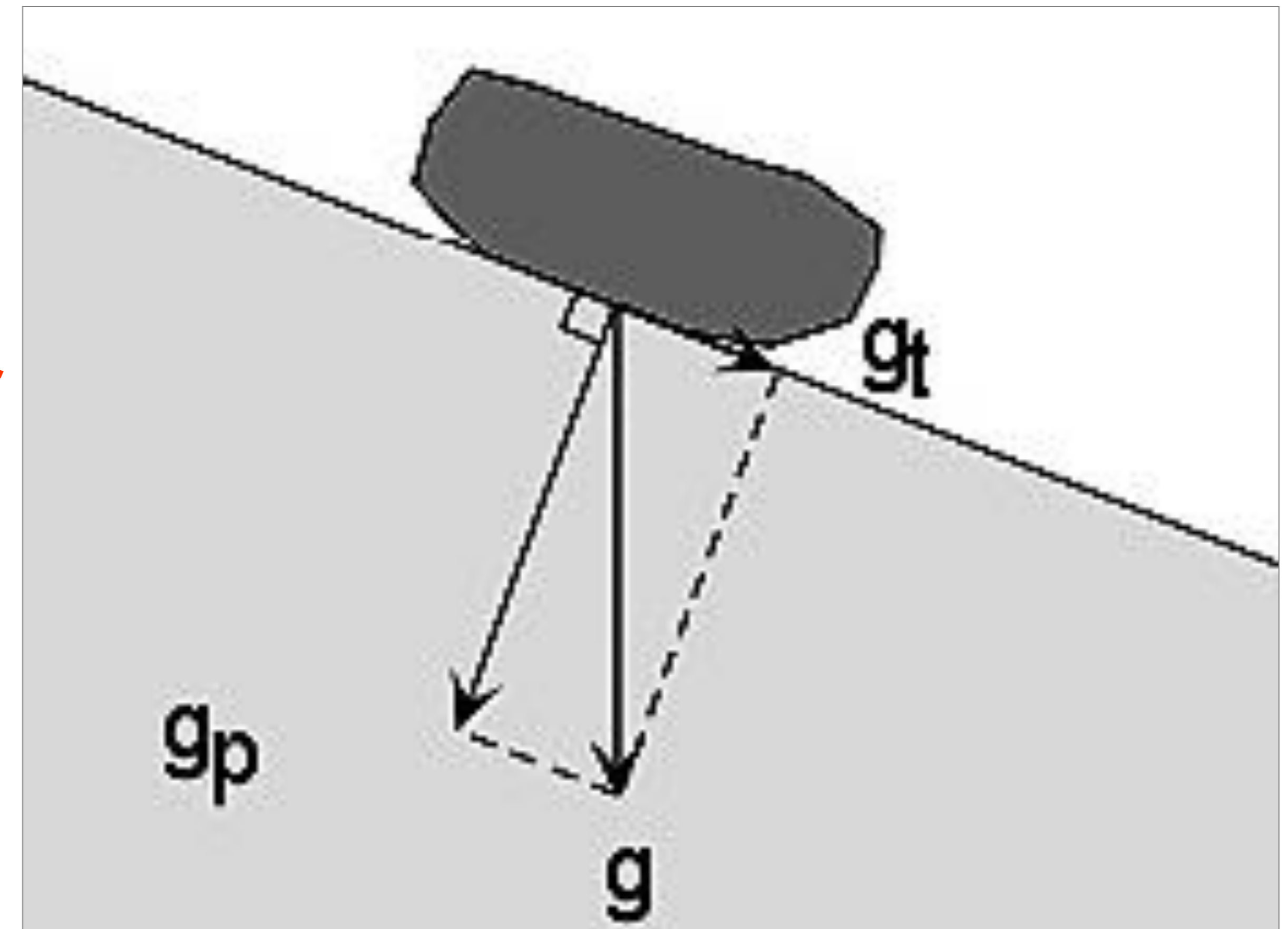

Sliding due to Gravitational Loading.....contd.

- Perpendicular component of gravity, g_p , helps to hold object in place on the slope.
- Tangential component of gravity, g_t , causes shear stress parallel to slope & helps to move object in downslope direction.
- When shear forces become $>$ forces holding object on slope, object will move down-slope, as steep slope angles
 - increase shear stress, &
 - result in reduction of **COHESION** among particles and **lowering of FRICTIONAL** resistance.

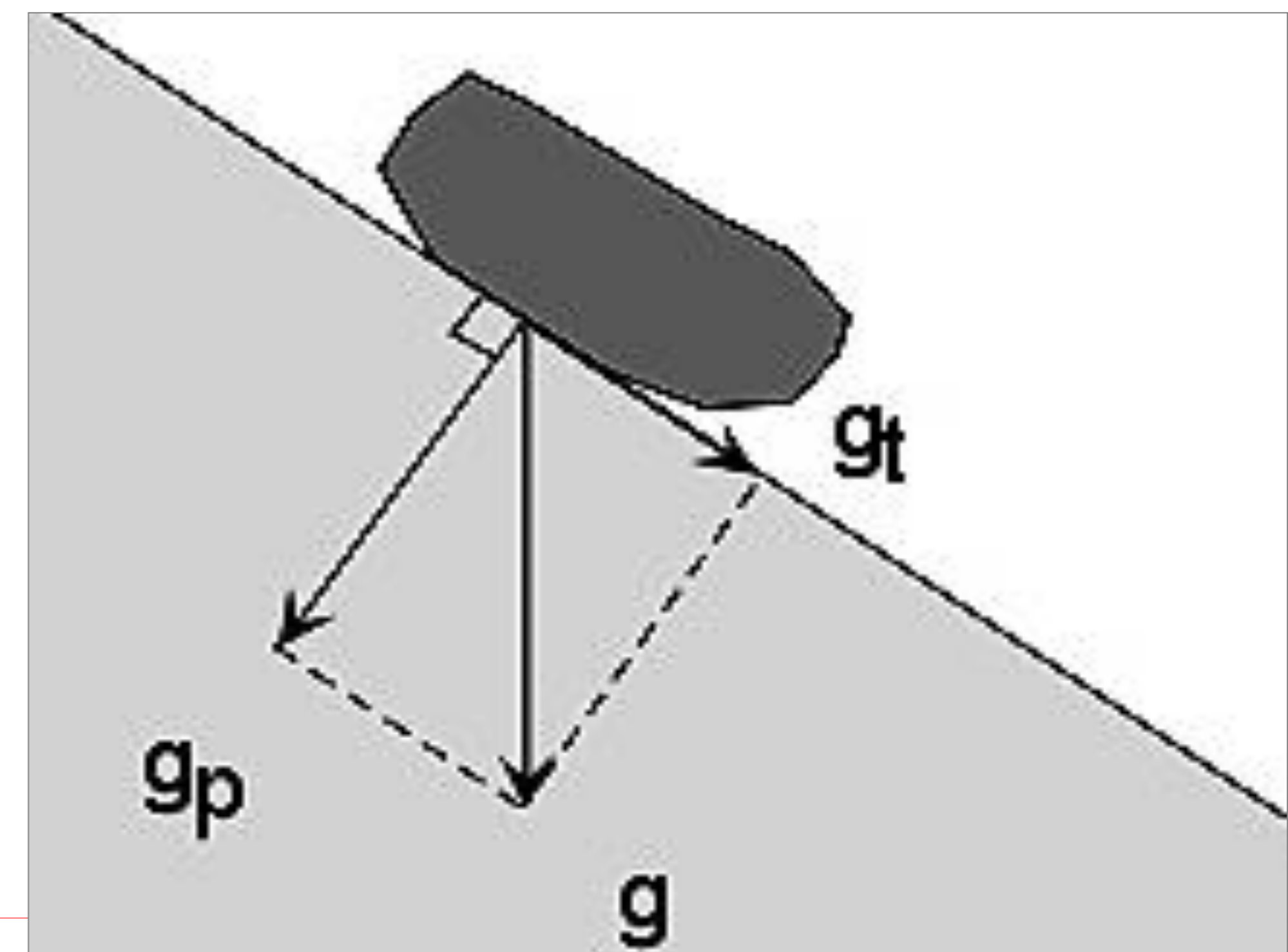
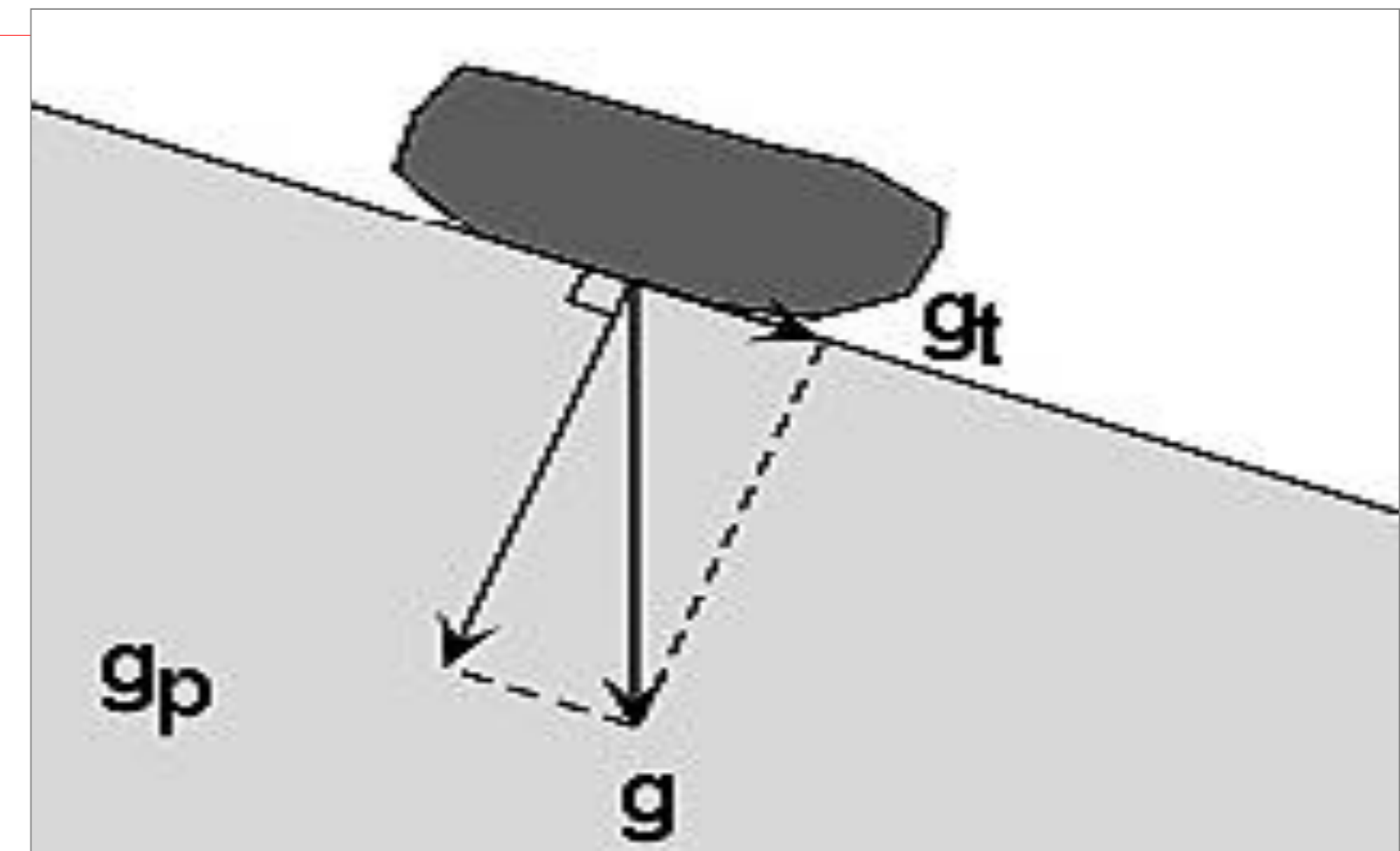

Factors Influencing Slope Stability

a) Geologic Discontinuities in Rock Masses

These include:

- *Joints*
- *Bedding*
- *Faults including their*
 - *Spacing, and*
 - *Altitude*

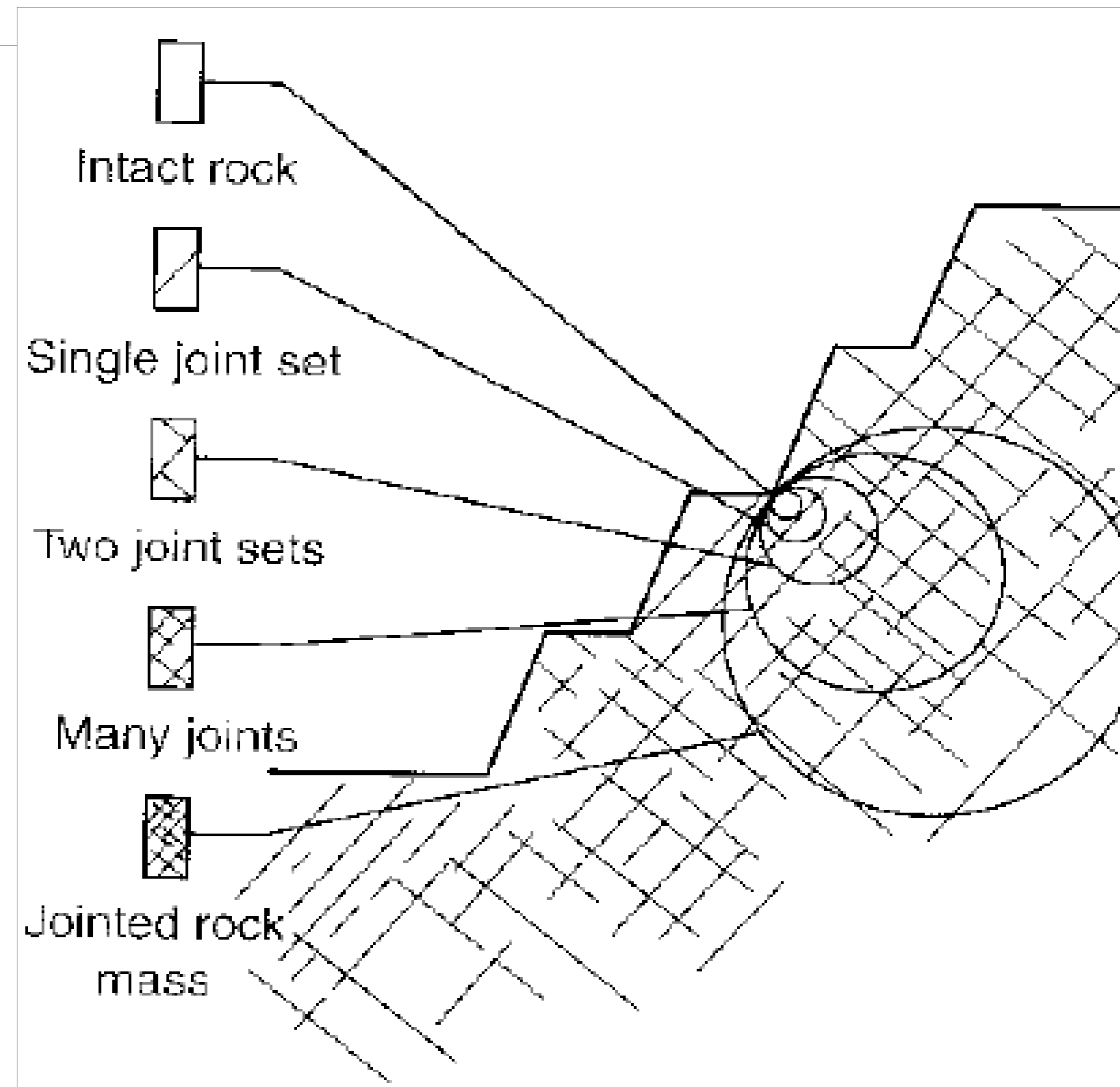

Idealized diagram showing transition from intact rock to jointed rock mass with increasing sample size

Factors Influencing Slope Stability.....contd.

b) Geologic Structure

In open pits, this includes:

- amount & direction of dip of critical planes.
- faults that act as groundwater conduits & influence weathering & alternation
- intra-formational shear zones that;
 - reduce shear strength
 - change permeability & act as sub surface drain
 - act as planes of failure

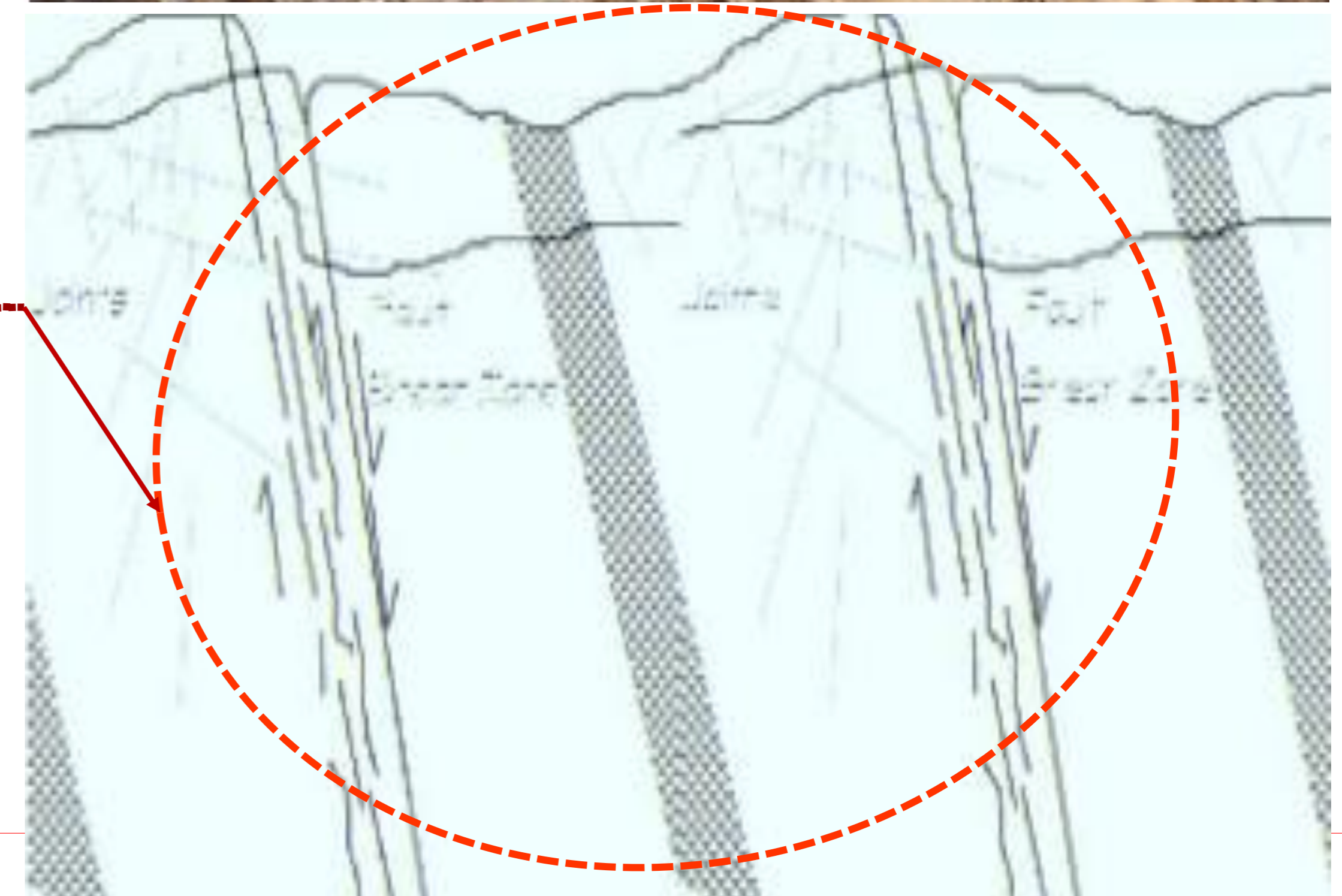

Factors Influencing Slope Stability.....contd.

c) Geotechnical Properties

These include:

- **Shear strength of rock mass**
- **Cohesion (c)** – characteristic property of a rock or soil that measures how well material resists being deformed or broken by forces.
- **Angle of Internal friction (ϕ)** – measured between normal stress (σ_n) and shearing stress (τ) attained at the point of failure...

Factors Influencing Slope Stability.....contd.

c) Geotechnical Properties (contd.)

➤ Permeability/groundwater situation

- *alters cohesion and frictional parameters;*
- *increases up-thrust and driving water forces with adverse effect on stability of slopes;*
- *alter cohesion & friction of discontinuity surface....*
- *Alters moisture content of geologic masses*

➤ Particle size distribution

2. COMPUTATION OF FORCES / STRESSES

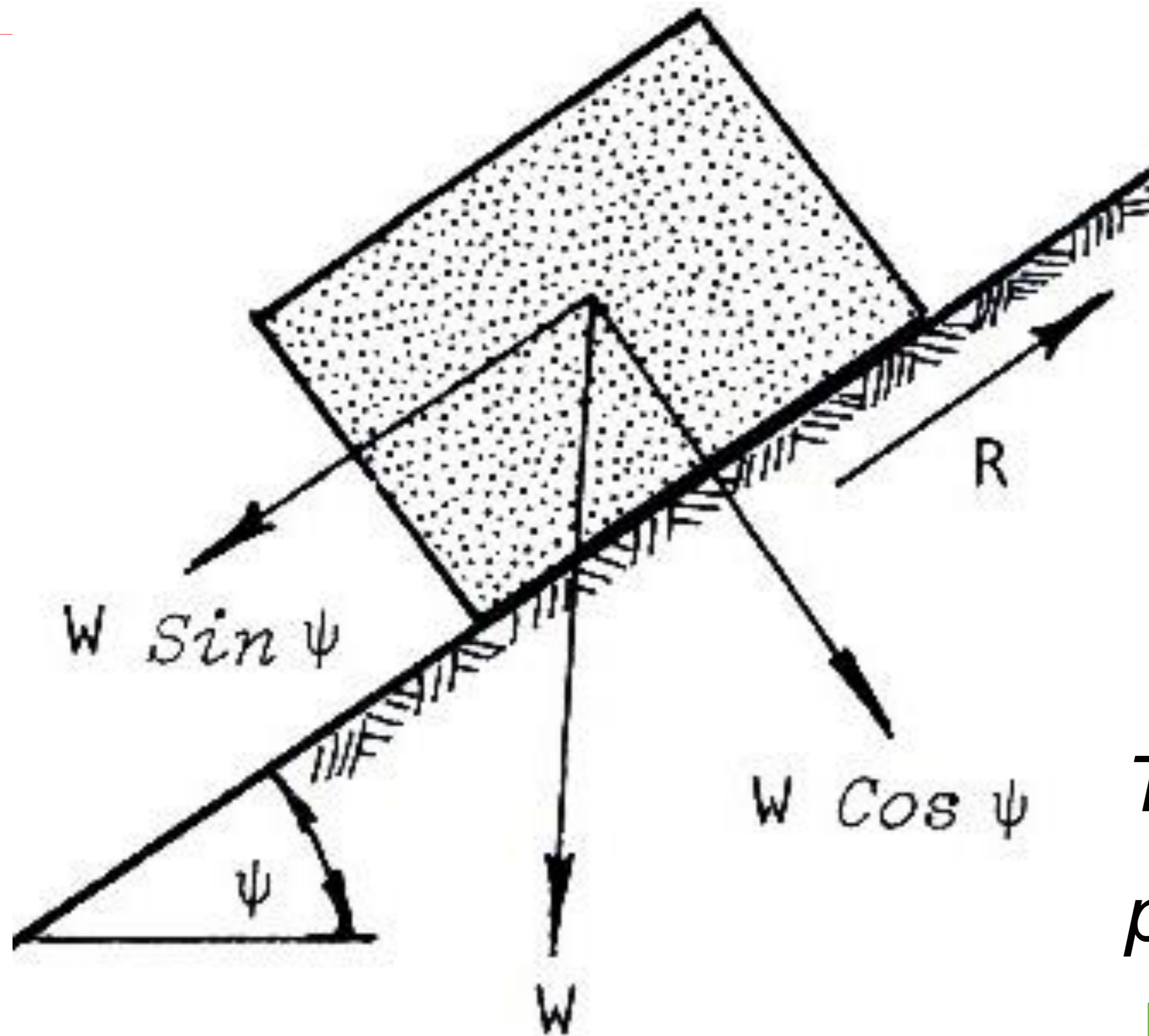

From previous e.gs., component of W acting across plane & which tends to stabilise slope is:

$$W \cos \psi$$

The NORMAL stress, σ , acting across potential sliding surface is:

$$\sigma = \frac{(W \cos \psi)}{A} \quad \text{.....} \quad (1)$$

Where A is base area of block

2. Computation of Forces / Stresses.....contd.

Recall that:

$$\tau = c + \sigma \tan \phi \quad (2)$$

Substituting for NORMAL stress in equation 1, gives:

$$\tau = c + \frac{(W \cos \psi)}{A} \tan \phi \quad (3)$$

or

$$R = c A + (W \cos \psi) \tan \phi \quad (4)$$

Where $R = \tau A$ is **SHEAR FORCE** resisting sliding down plane

2. Computation of Forces / Stresses.....contd.

Block will be just on point of sliding or condition of *LIMITING*

EQUILIBRIUM, when:

Disturbing Force acting down plane is **EXACTLY EQUAL** to

Resisting Force

$$W \sin \psi = c A + W \cos \psi \tan \phi \quad \text{-----} (5)$$

2.1 Effect of water pressure on Discontinuity Shear strength

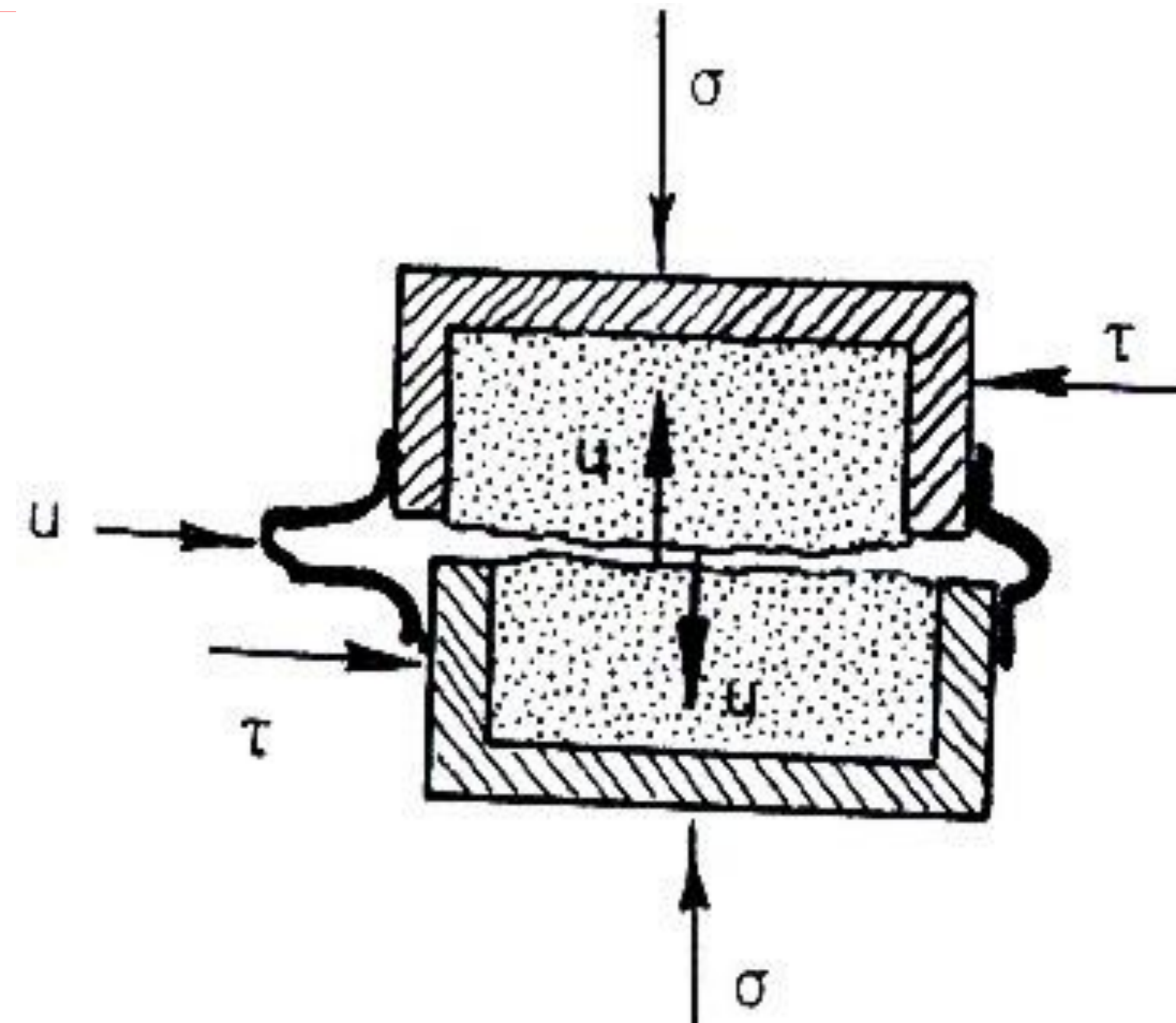
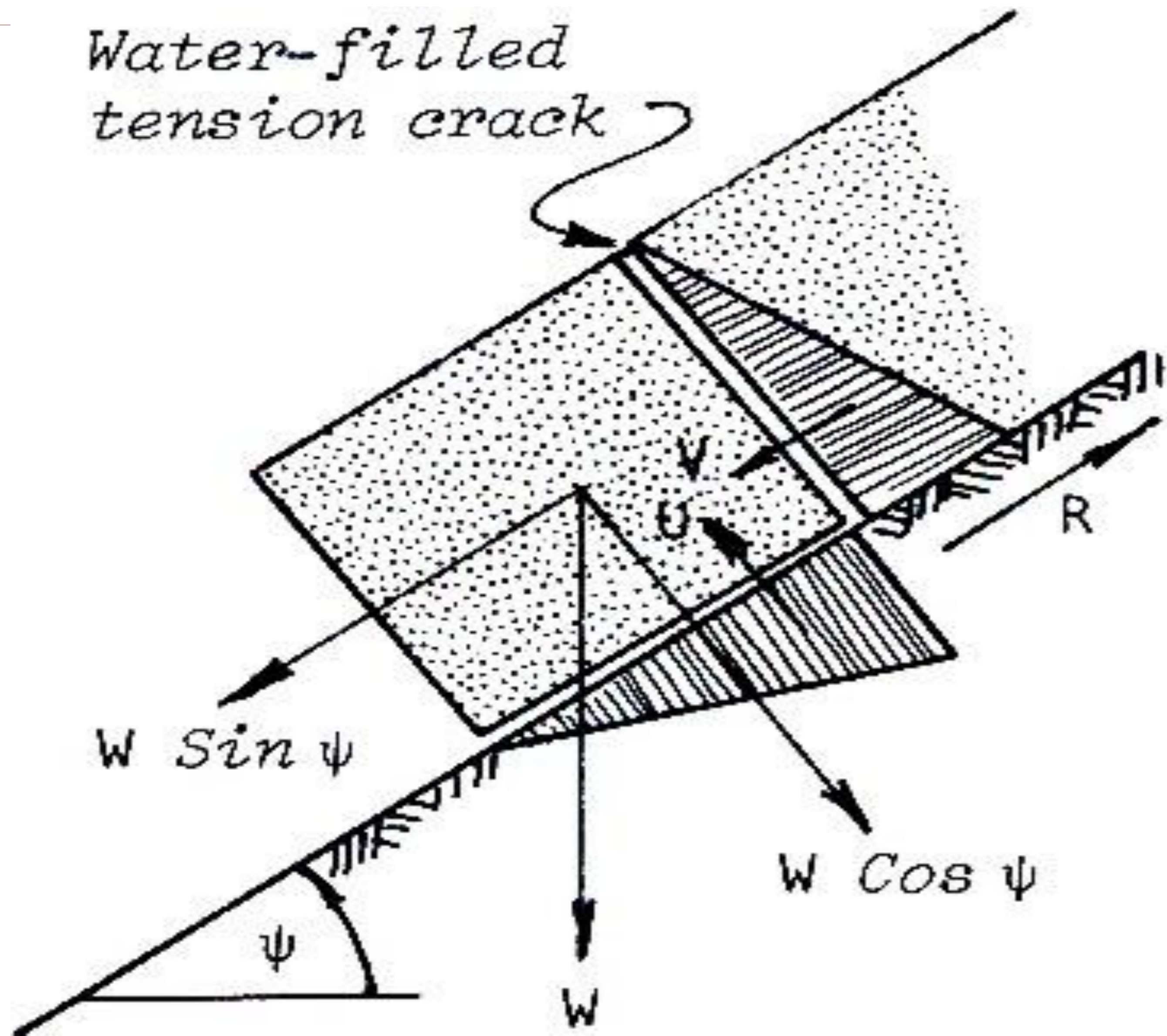

Condition of **LIMITING EQUILIBRIUM** for this case is defined by:

$$W \sin \psi + v = c A + (W \cos \psi - u) \tan \phi \quad (6)$$

2.1 Effect of water pressure on Shear strength.....contd.

$$W \sin \psi + v = c A + (W \cos \psi - u) \tan \phi$$

From this equation, it can be seen that:

- Force promoting sliding is **INCREASED** by **v**
- Frictional force resisting sliding is **DECREASED** by **u**
- Both **u** & **v** result in **DECREASES** in stability of slope
- Although water pressures involved may be small, they act over large areas and hence, very large water forces may be involved.

FACTOR OF SAFETY OF SLOPE

All equations defining stability of any slope have been presented for CONDITION OF LIMITING EQUILIBRIUM, i.e.:

➤ *Condition @ which Forces tending to induce sliding are*
EXACTLY BALANCED *by those resisting sliding*

FACTOR OF SAFETY OF SLOPE.....contd.

*To compare stability of slopes under conditions other than those of limiting equilibrium, some form of index is required – the **FACTOR OF SAFETY (FS)**, as follows:*

$$FS = \frac{\text{TOTAL FORCE resisting sliding}}{\text{TOTAL FORCE promoting sliding}}$$

FACTOR OF SAFETY OF SLOPE.....contd.

Considering case of block acted upon by water forces [equation (6) above], **FACTOR OF SAFETY** is given by:

$$F = \frac{c A + (W \cos \psi - u) \tan \phi}{W \sin \psi + v} \quad (7)$$

- At limiting equilibrium, **RESISTING & DISTURBING** forces are **EQUAL**, and $FS = 1$.
- When slope is stable, **RESISTING FORCES > DISTURBING FORCES** & value of FS will usually be greater than unity (1).

FACTOR OF SAFETY OF SLOPE.....contd.

Practical experience suggests that:

- ☑ A FS of 1.0 to 1.3 is adequate for mine slopes that are not required to remain stable for long periods.

 - ☑ For critical slopes adjacent to roads (or important installations), FS of 1.5 is usually preferred.
-

Reinforcement to Prevent Sliding

One most effective means of stabilising rock blocks:

➤ *install tensioned rock-bolts or cables.*

Consider block resting on inclined plane & acted upon by uplift force, u , and force v , due to water pressure in tension crack.

Stabilization of Slopes

One most effective means of stabilizing rock blocks, which are likely to slide is to install tensioned rock-bolts:

- ✓ used on rock masses that show signs of instability or on newly cut rock slopes to prevent movement along fractures
- ✓ are considered a type of active reinforcement due to the post-tensioning they provide
- ✓ are used to add compressive stress to joints within a rock mass, which increases friction along fracture planes and helps to reduce block movement.
- ✓ require more time to install....because installation involves drilling, grouting bonded length and inserting bar/cable, then tensioning anchor and grouting free length.

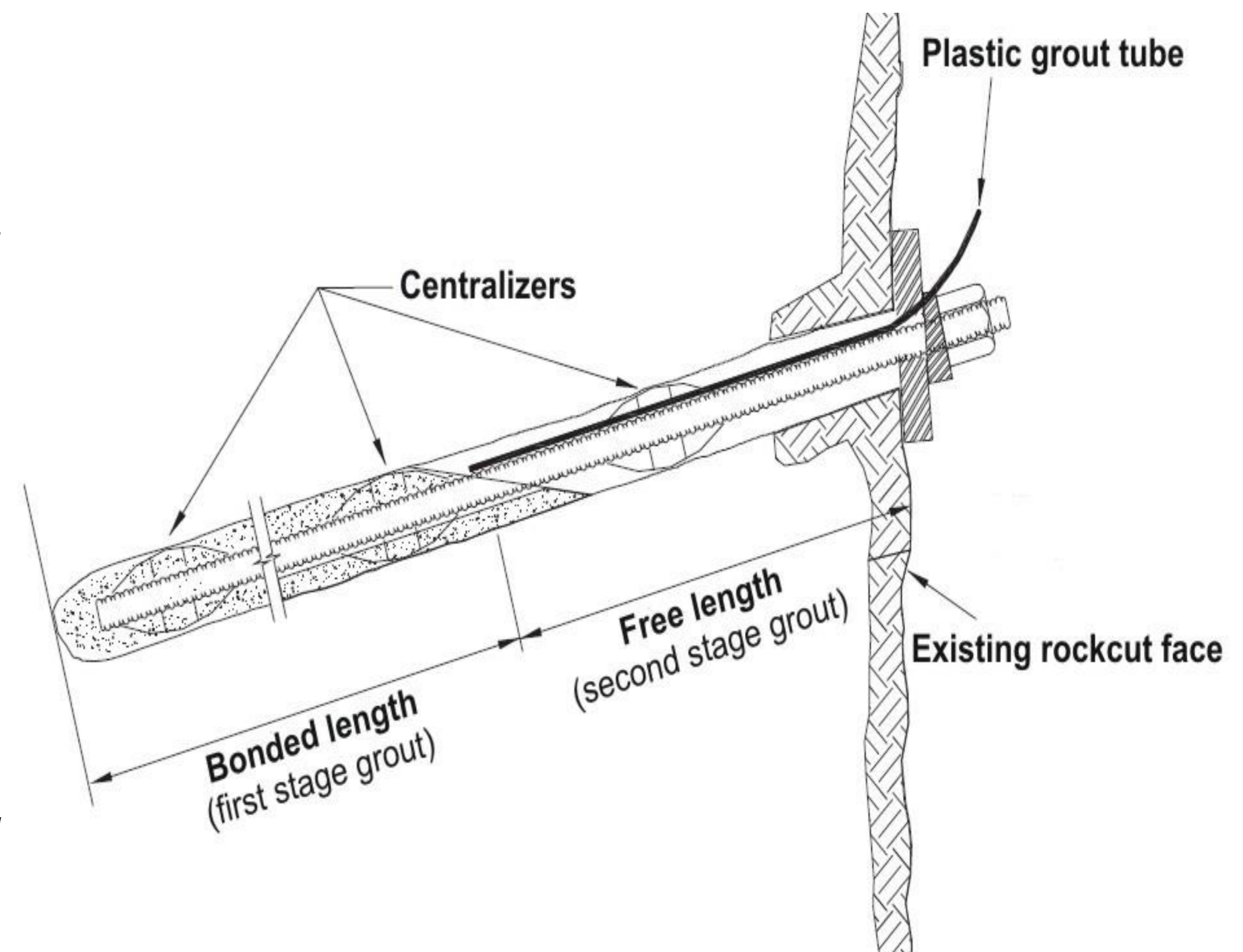

Stabilization of Slopes.....contd.

Consider block resting on inclined plane & acted upon by uplift force, u , and force v , due to water pressure in tension crack.

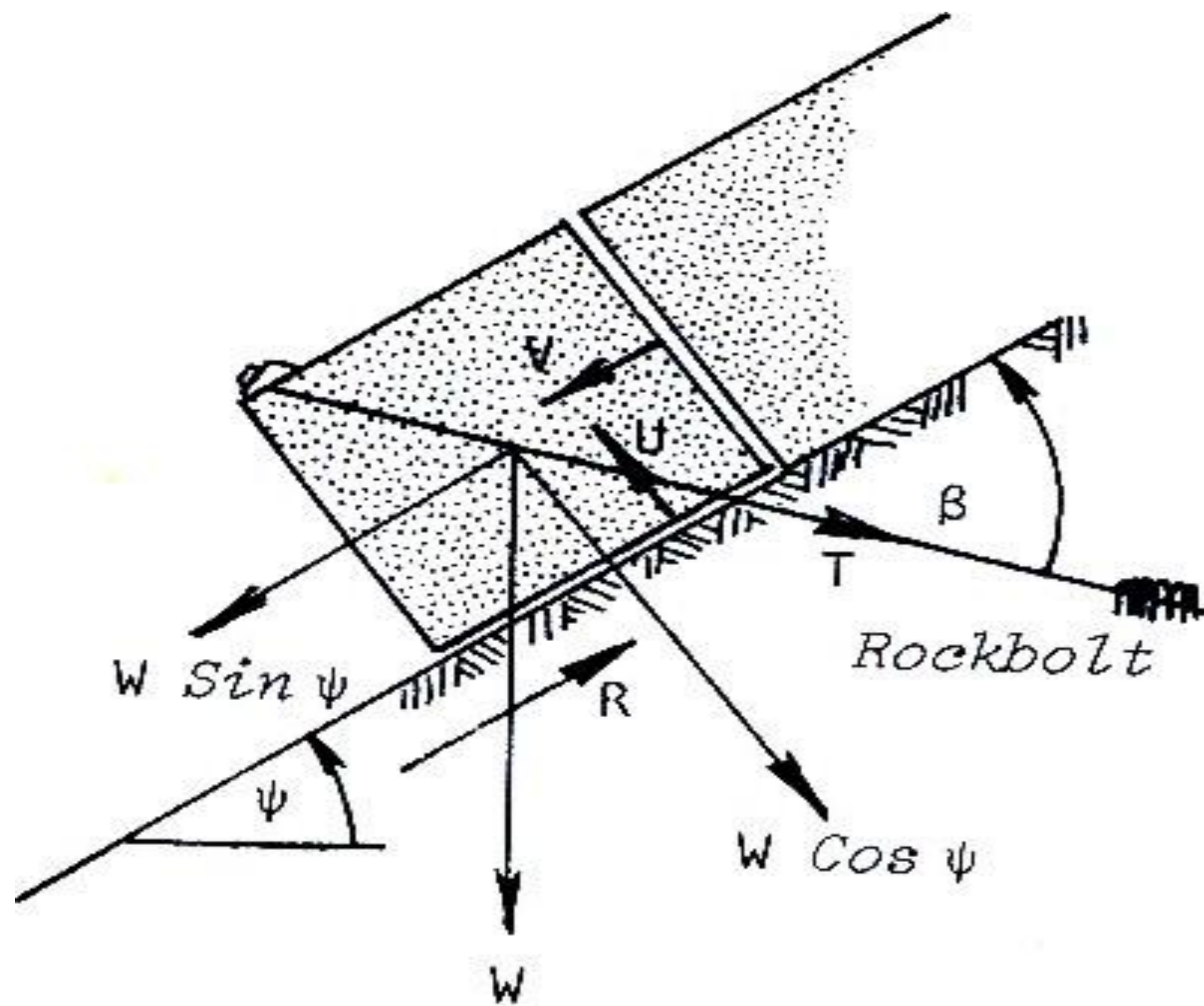

Rock-bolt, tensioned to load T is installed @ angle β to plane....

Resolved component acting along surface, upon which block resists is

$$**T \cos \beta**$$

Stabilization of Slopes.....contd.

Condition of limiting equilibrium for this case is defined by:

$$W \sin \psi + v - T \cos \beta = c A + (W \cos \psi - u + T \sin \beta) \tan \phi \quad \text{---(7)}$$

Equation shows that bolt tension:

👉 **Reduces DISTURBING FORCE** acting down plane

👉 **Increases NORMAL FORCE** and hence **FRICTIONAL RESISTANCE** between base of block & plane.

Stabilization of Slopes.....contd.

To assess, whether or not this block is now stable is by determination of FACTOR OF SAFETY. Considering case of block acted upon by water forces [equation (6) above], FACTOR OF SAFETY is given by:

$$F = \frac{cA + (W \cos \alpha - u + T \sin \beta) \tan \varphi}{W \sin \alpha + v - T \cos \beta}$$

Stabilization of Slopes.....contd.

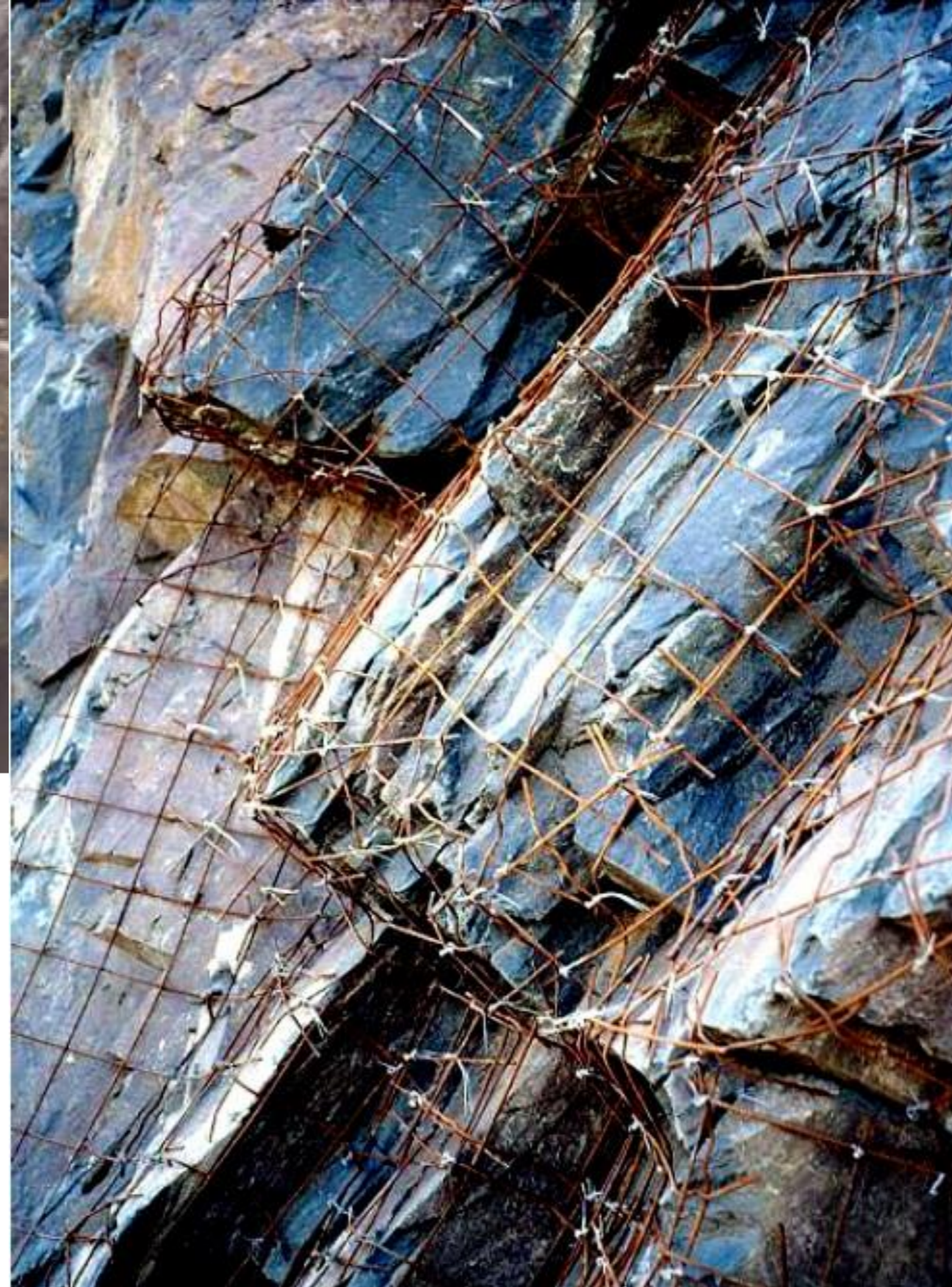

Slope Failures for which Factors of Safety can be calculated

1. **Translational** – encompasses **plane** and **wedge** failures

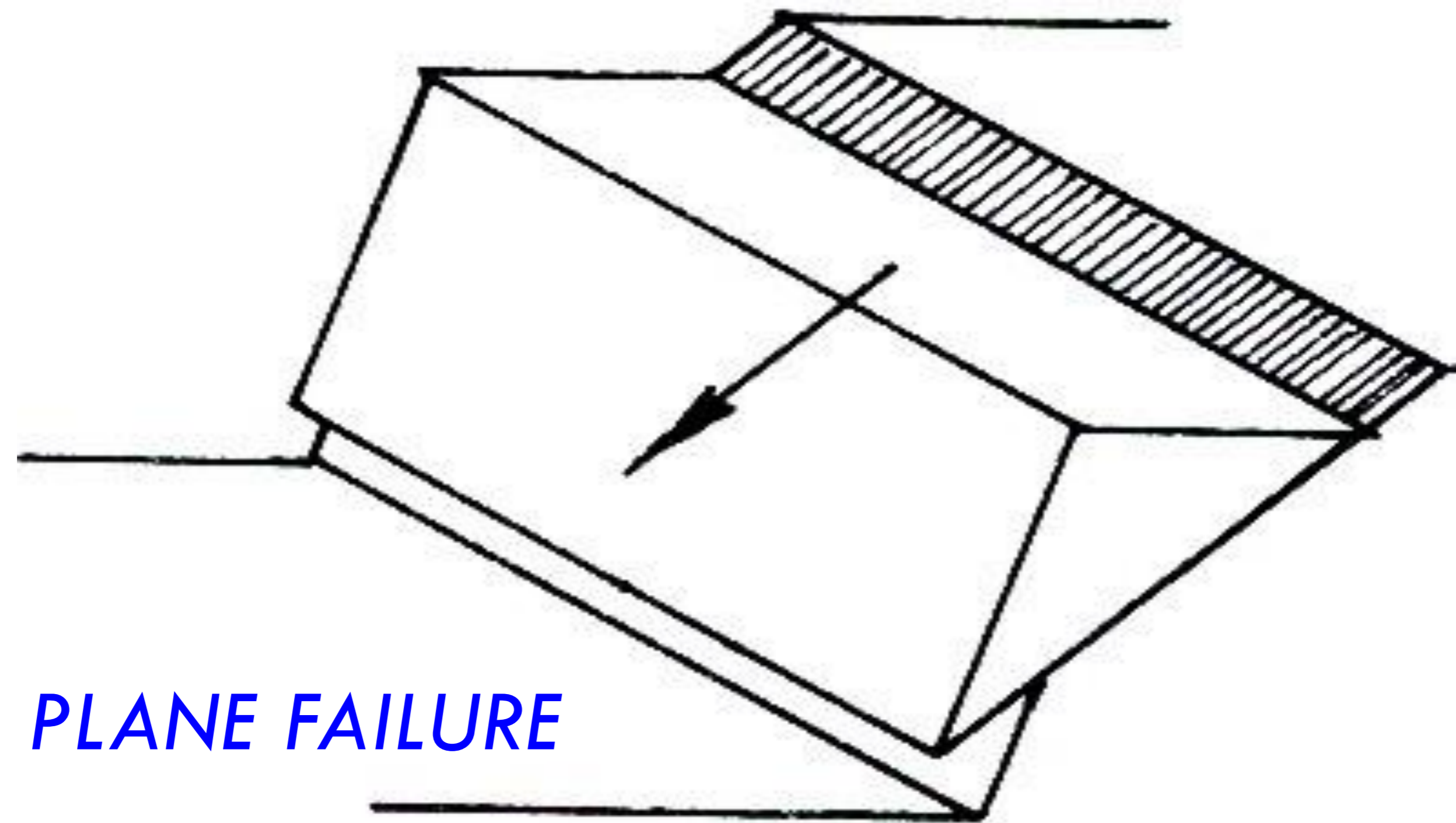

a) Plane failure – occurs when discontinuities – joints, bedding – strike parallel to the slope face and dip into the excavation at an angle $>$ **angle of friction**.

Slope Failures for which Factors of Safety can be calculated.....contd.

For example:

If sedimentary rock layers dip in the same direction as slope, upper layers may slide over the lower ones.

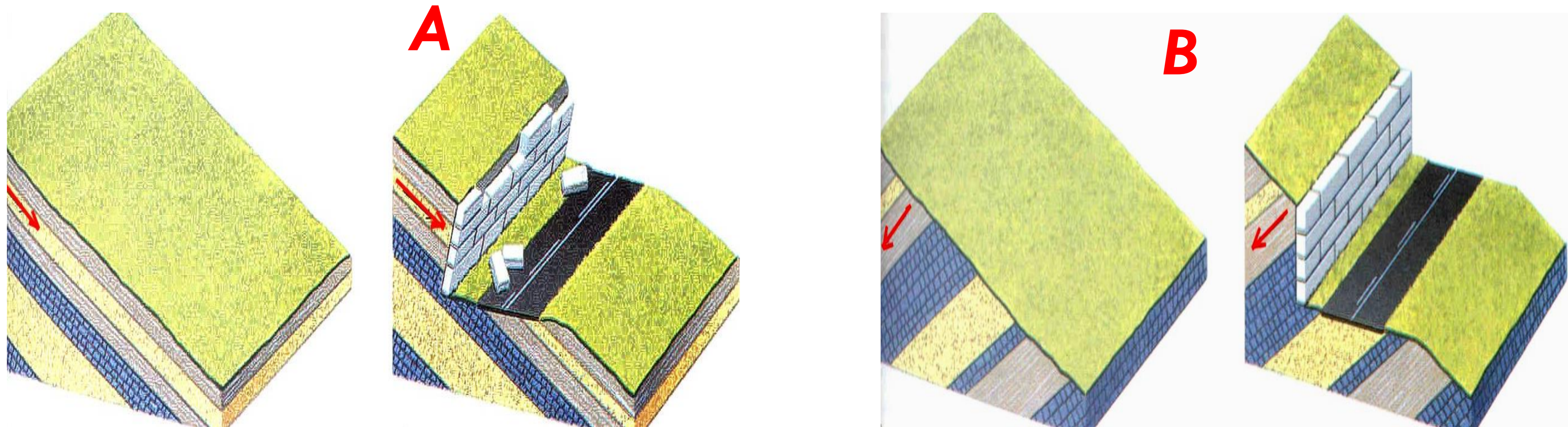

(A) If road cut undermines slope, where rocks dip parallel to slope, dipping rock provides good sliding surface. (B) Slope will remain stable even when undermined if rock layers dip away from cut.

Slope Failures for which Factors of Safety can be calculated.....contd.

b) Wedge failure occurs when

- *line of intersection of two discontinuities striking obliquely **daylights** into slope face.*
- *Wedge of rock resting on discontinuities slides down line of intersection **provided inclination of the latter is significantly greater than the angle of friction.***

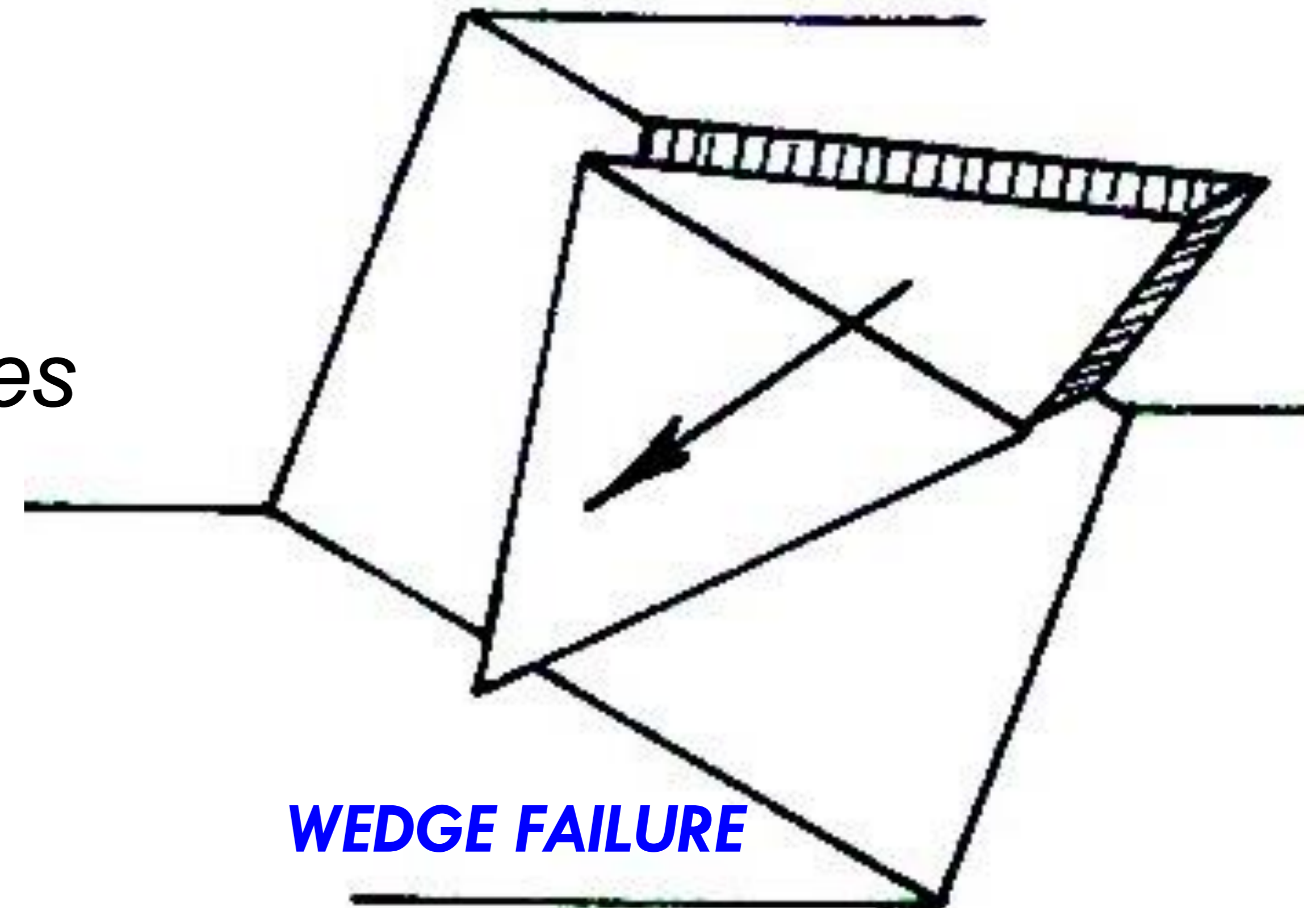

Orientation of Engineering works to Discontinuity Orientations.....contd.



Orientation of Engineering works to Discontinuity Orientations.....contd.

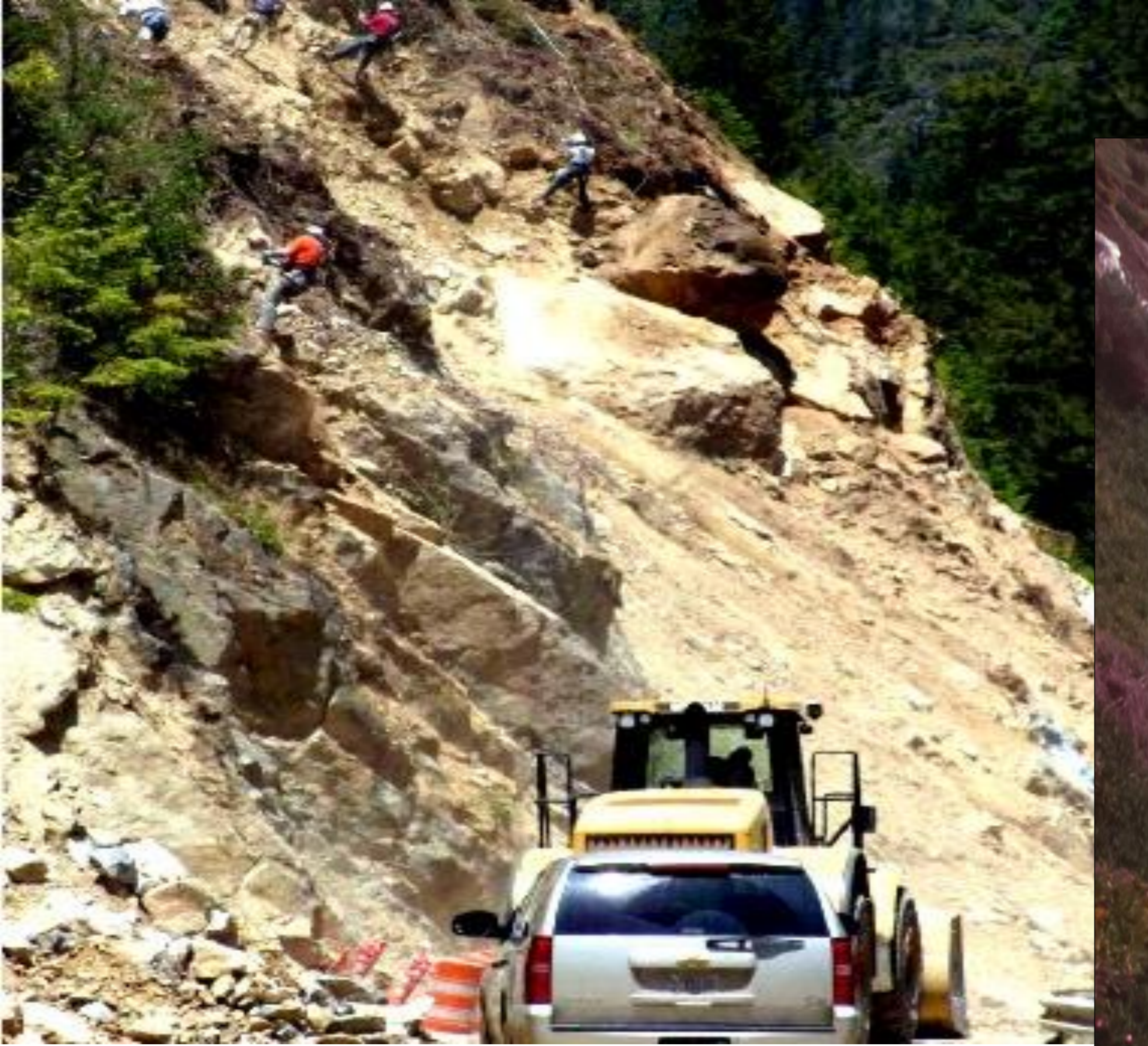

Triggering Mechanisms

Slope failure can occur any time a slope becomes unstable. This may be due to:

- a) *Modification of slope* either by humans or by natural causes can change the slope angles, e.g. by **Undercutting**

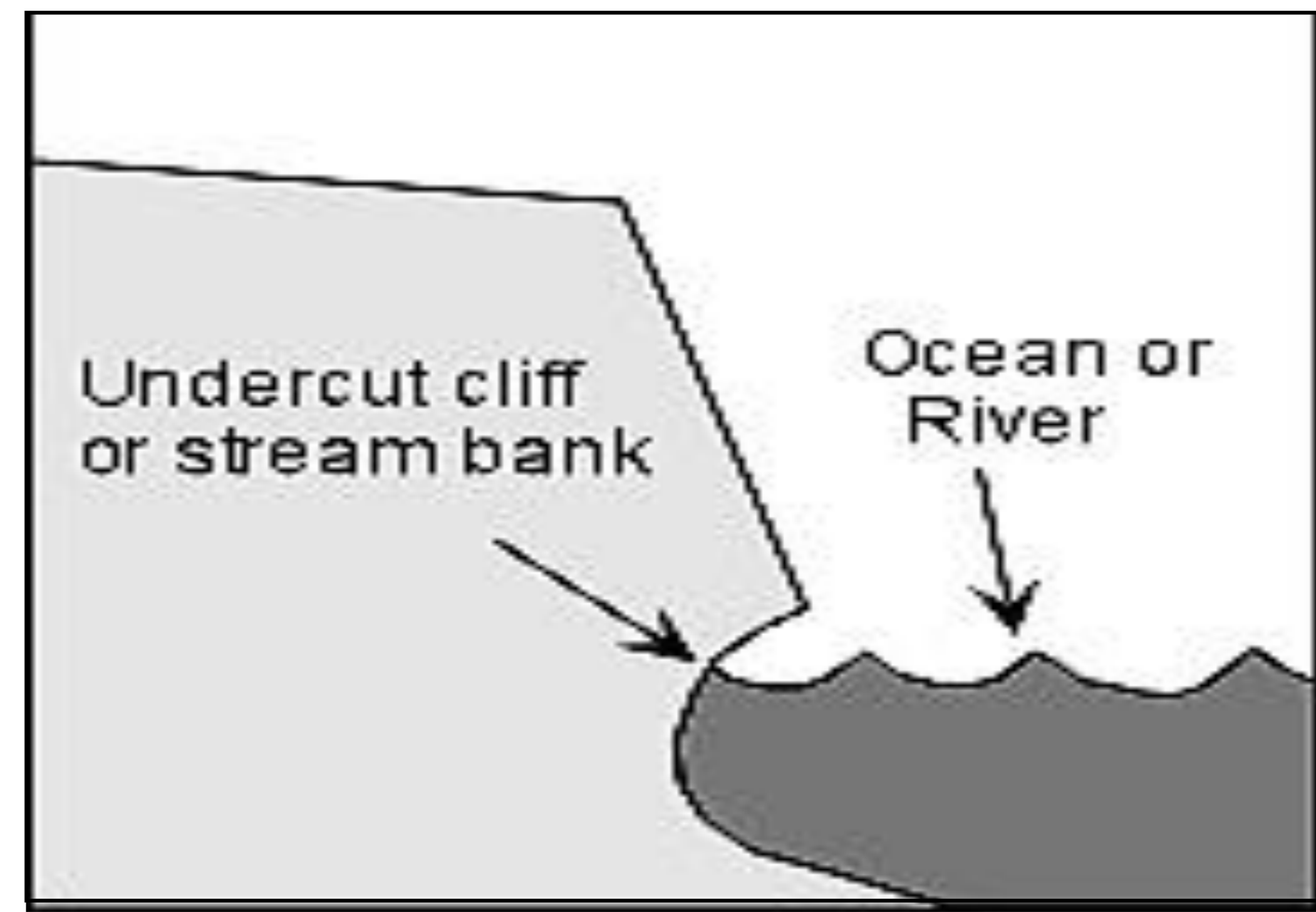
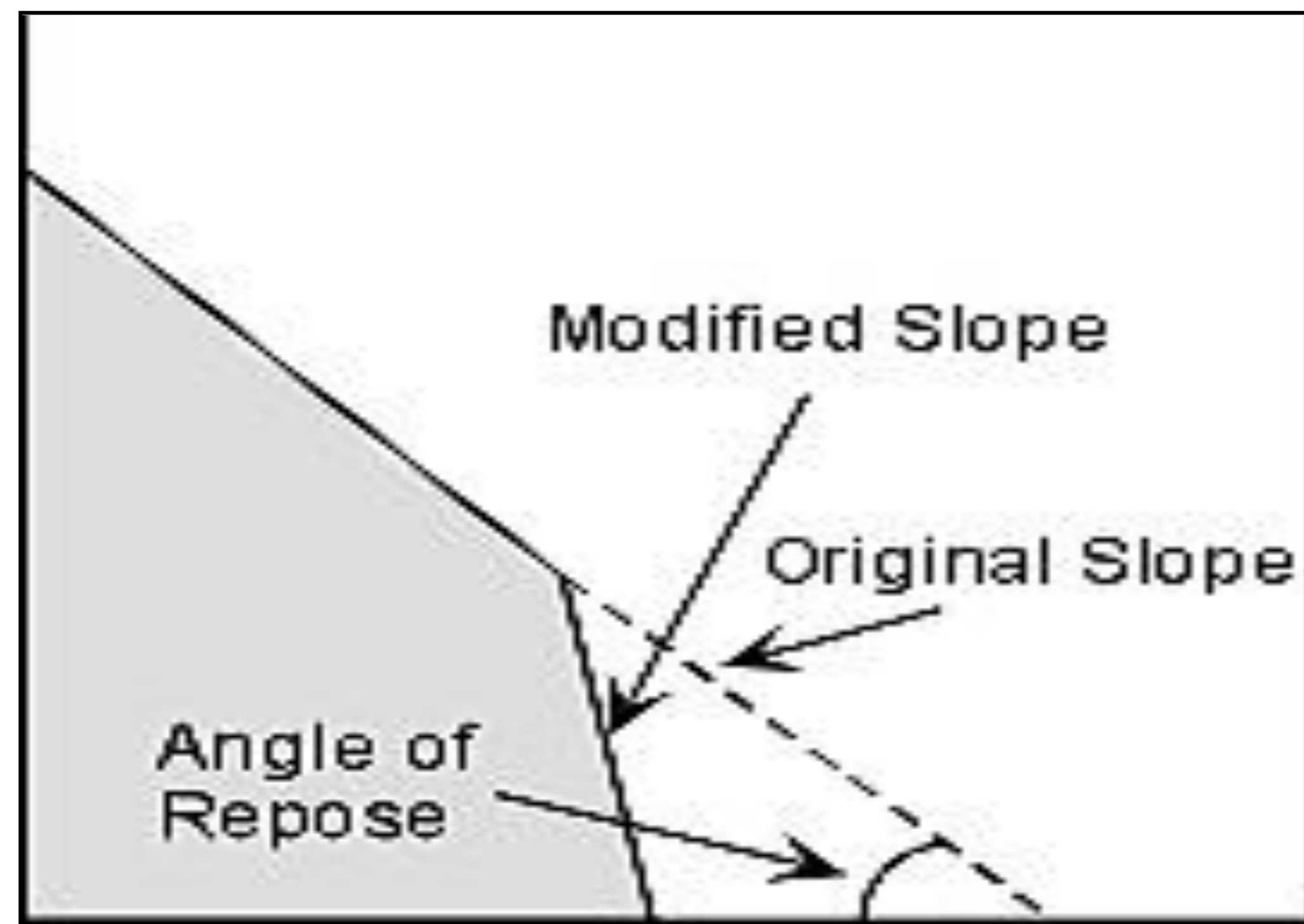

Triggering Mechanisms.....contd.

b) Sudden addition of moisture to rock/soil mass.

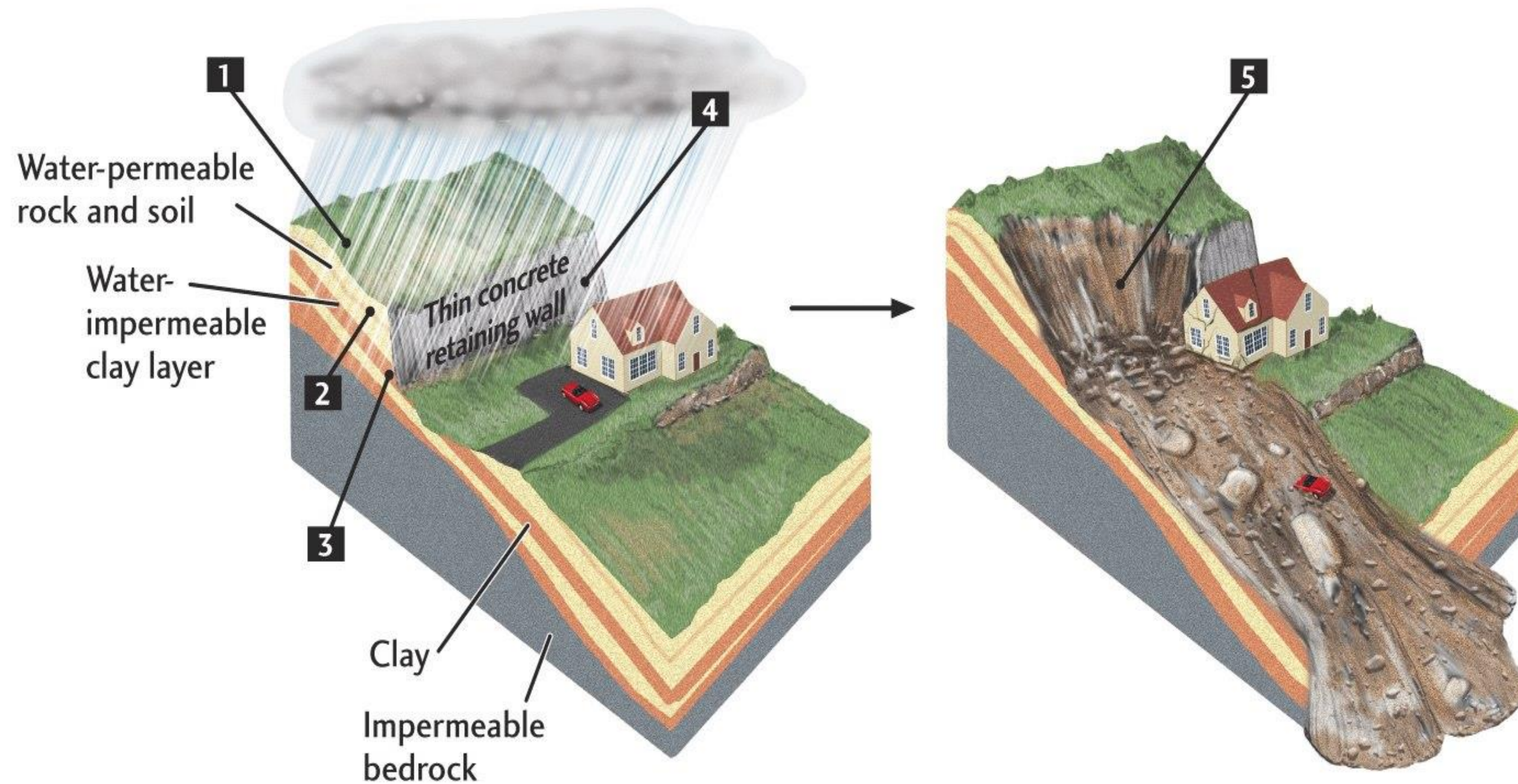

Triggering Mechanisms.....contd.

c) Shocks – A sudden shock/shake of ground by, e.g. an earthquake, may trigger a slope instability thru **Liquefaction**

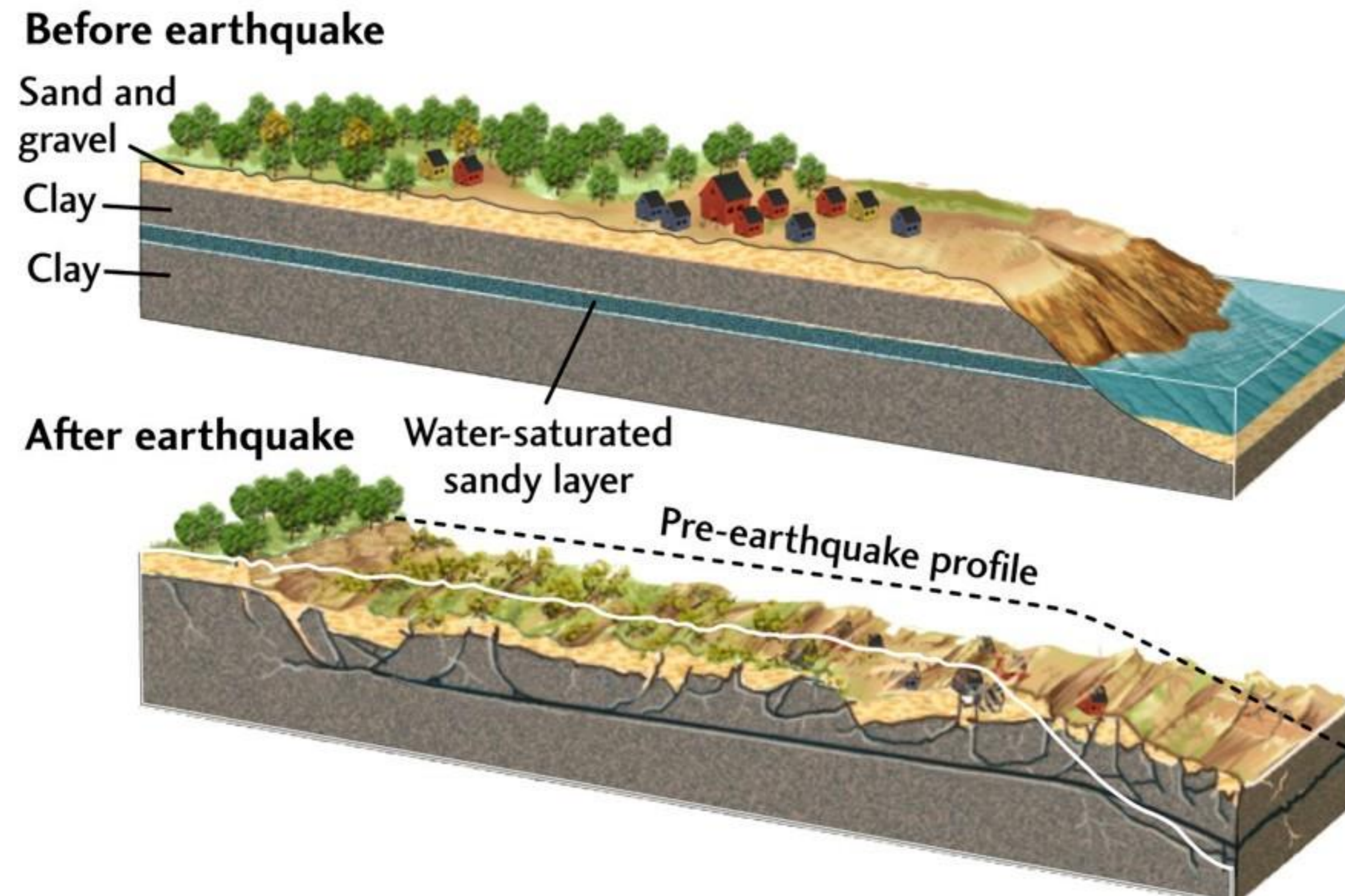

Triggering Mechanisms.....contd.

d) Undercutting phenomena

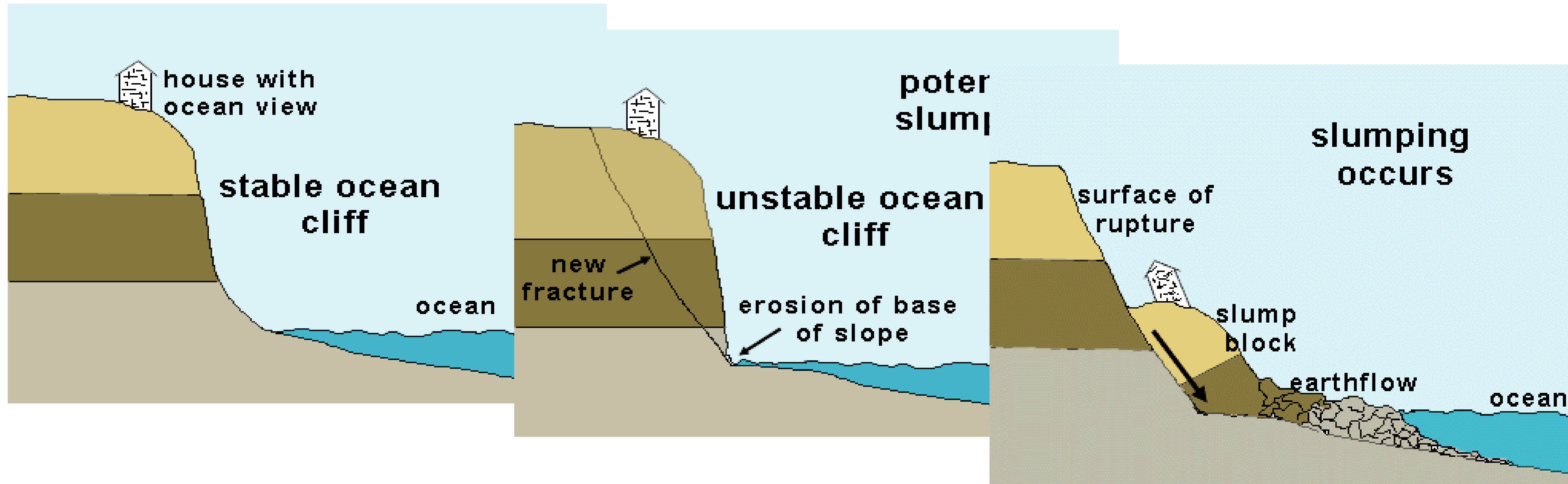

In diagram 1, the residents of the house have a fine ocean view, with stable rocks below them

In diagram 2, ocean waves have removed the base of the slope beneath the house. Removal of support will result in formation of a fracture.. Residents will see a widening crack cutting across their lawn...

Diagram 3 shows that the slump block has slid downward along the surface of rupture,

Examples of Some Slope Failure Mechanisms

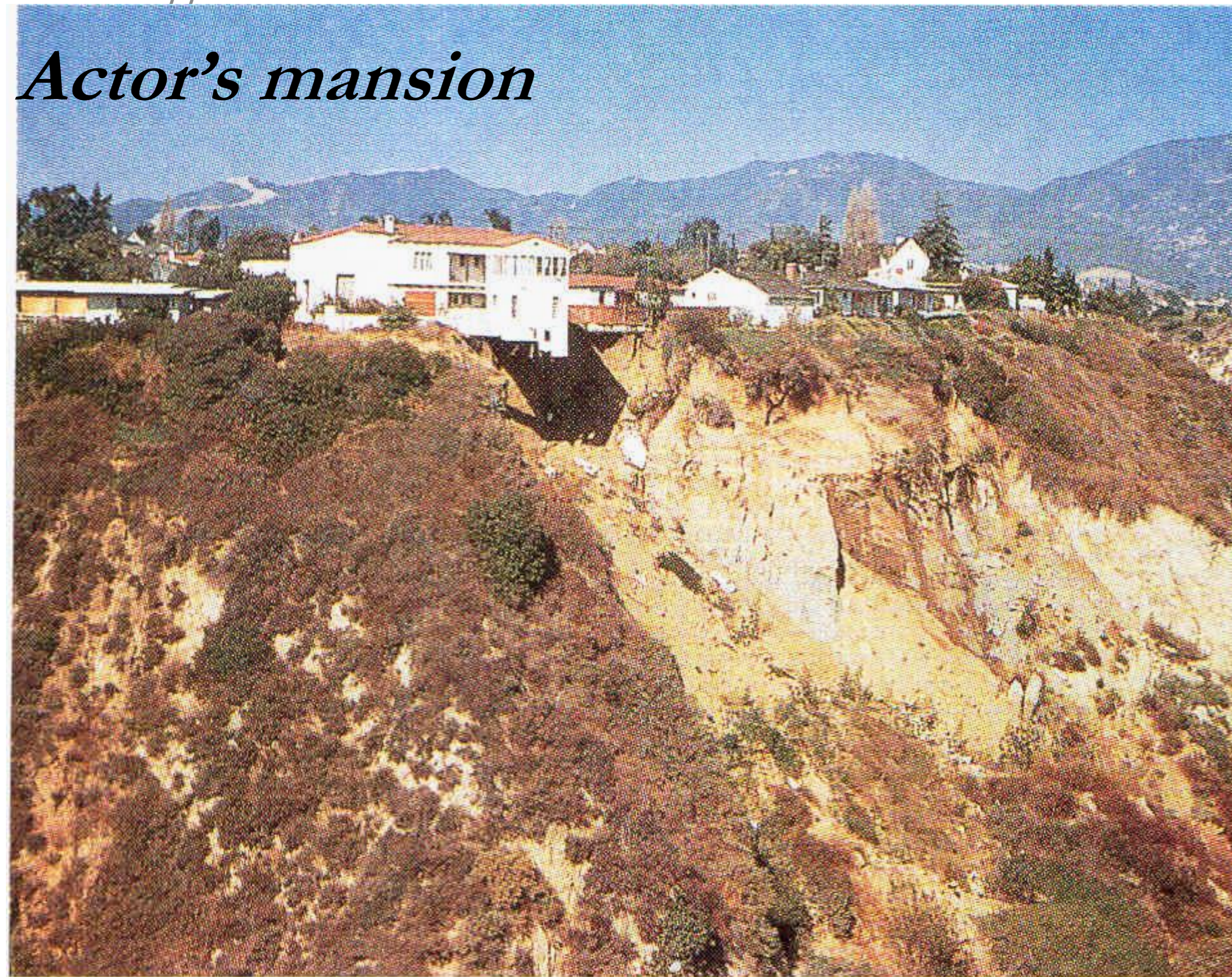

House fell a few days after this photo was taken

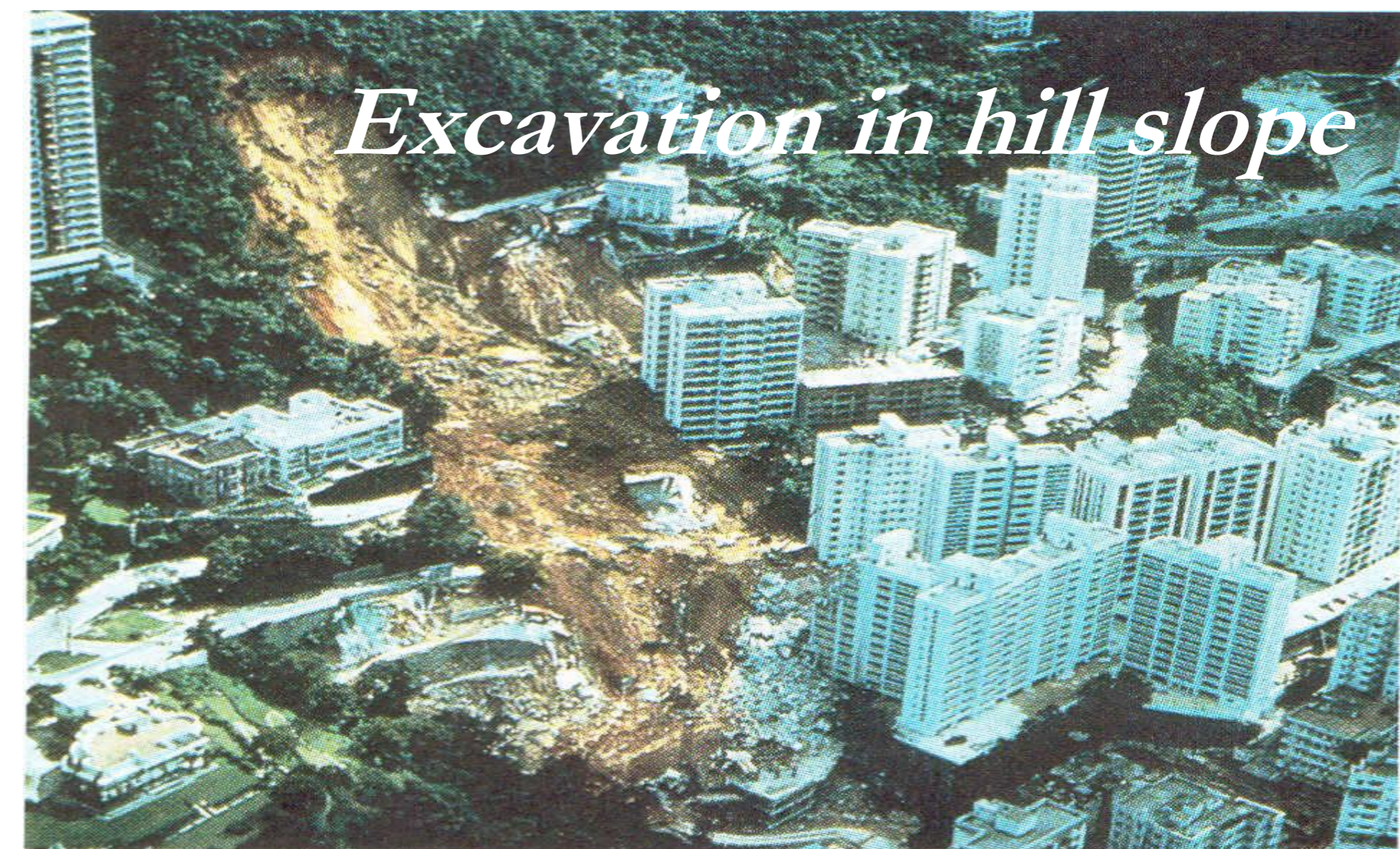
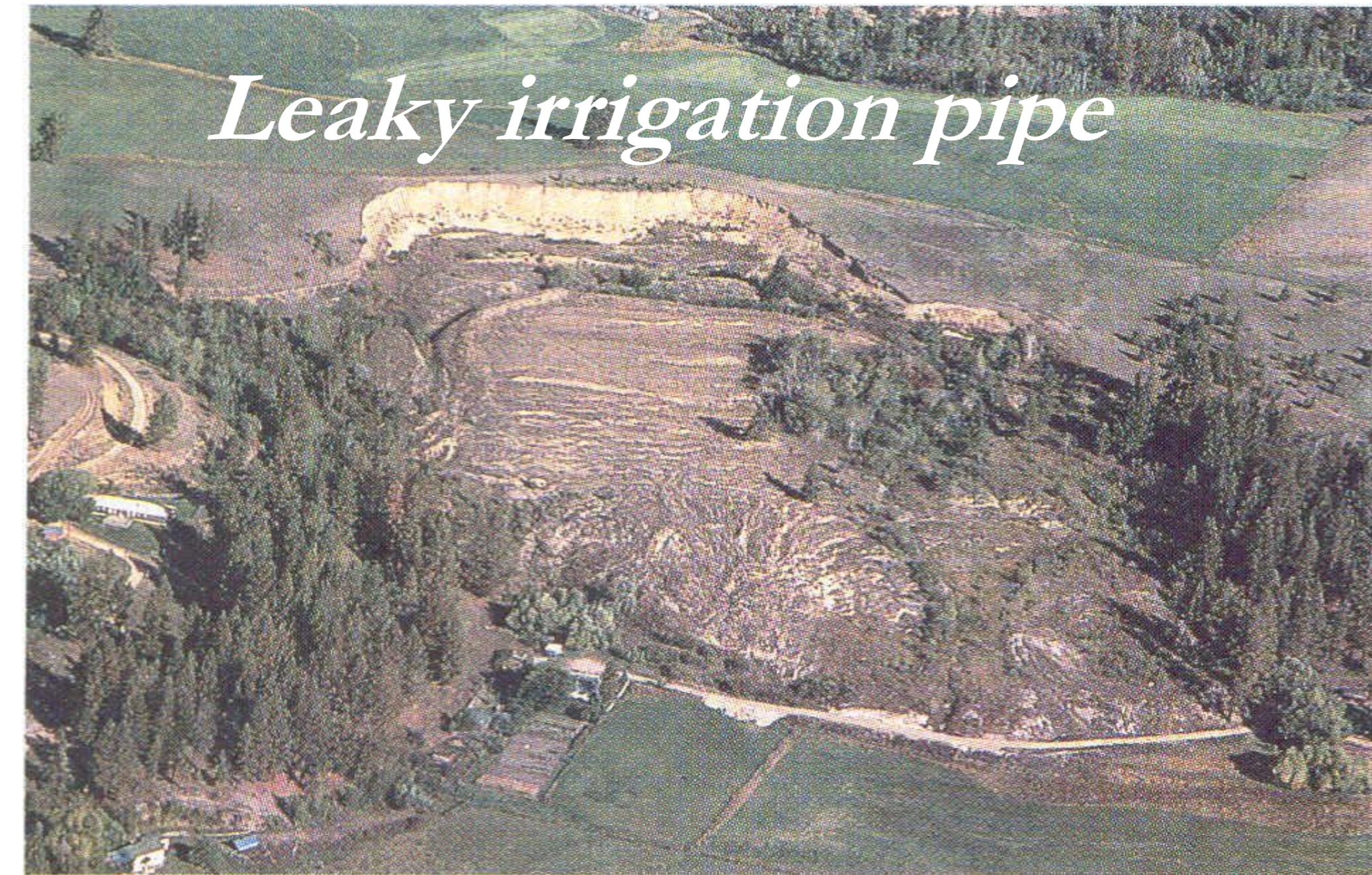

Examples of Some Slope Failure Mechanisms.....contd.



Bending of tree-trunks – indicative of gradual movement of the slope in creep

Examples of Some Slope Failure Mechanisms.....contd.



Flow failures in pictures

Examples of Some Slope Failure Mechanisms.....contd.



PREDICTING AND AVOIDING SLOPE FAILURES

- *Landslides commonly occur on same slopes as earlier ones bcoz geologic conditions that cause mass wasting tend to:*
 - ⇒ *Be constant over a large area*
 - ⇒ *Remain constant for long periods of time.*
 - ⇒ *If a hillside has slumped, nearby hills may also be vulnerable to mass wasting.*
 - ⇒ *landslides and mudflows commonly follow paths of previous slides and flows.*
-

Predicting and Avoiding Slope Failures.....contd.

- ⇒ If an old mudflow lies in a stream valley, future flows may follow the same valley.
- ⇒ Awareness and avoidance are the *most* effective defences against mass wasting.

