

# Fluid Mechanics CEE 3311

## LECTURE 12

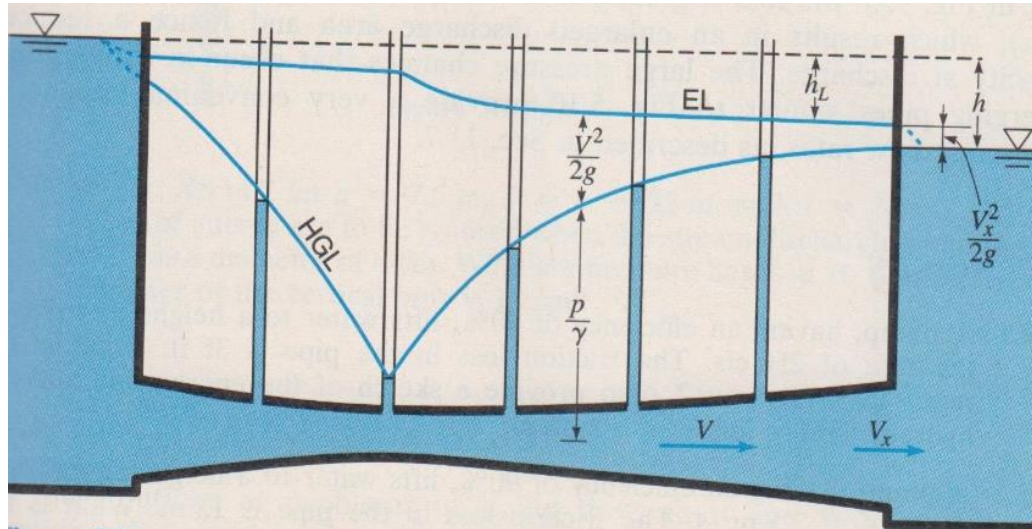

**Conservation of energy**

**Concept of hydraulic and  
energy grade lines**

L. Handia

Since each element of the energy equation or the Bernoulli equation has the dimension of length, it may be presented graphically with reference to an arbitrary datum level:

The **hydraulic grade line** (HGL) represents the locus of the piezometric head  $h = p/\rho.g + z$  along the flow, while the **energy grade line** (EGL) represents the locus of the total head  $H = p/\rho.g + z + \alpha.(V^2/2g)$  along the flow.

The locus of points of the piezometric head and total head, respectively, are set out vertically above the centre line of the pipe. The total head in the system is greater than the piezometric head by an amount  $\alpha.(V^2/2g)$ . Consequently, the EGL is above the HGL by a distance  $\alpha.(V^2/2g)$  (see Fig. 7.3). Strictly speaking, each streamline has its own HGL and EGL. When "one-dimensional flow" is assumed, it is usual to consider only the streamline in the centre of the pipe. Then the  $z$

measurements are taken to the centre line and the pressure head  $p/\rho.g$  is measured upwards from there.

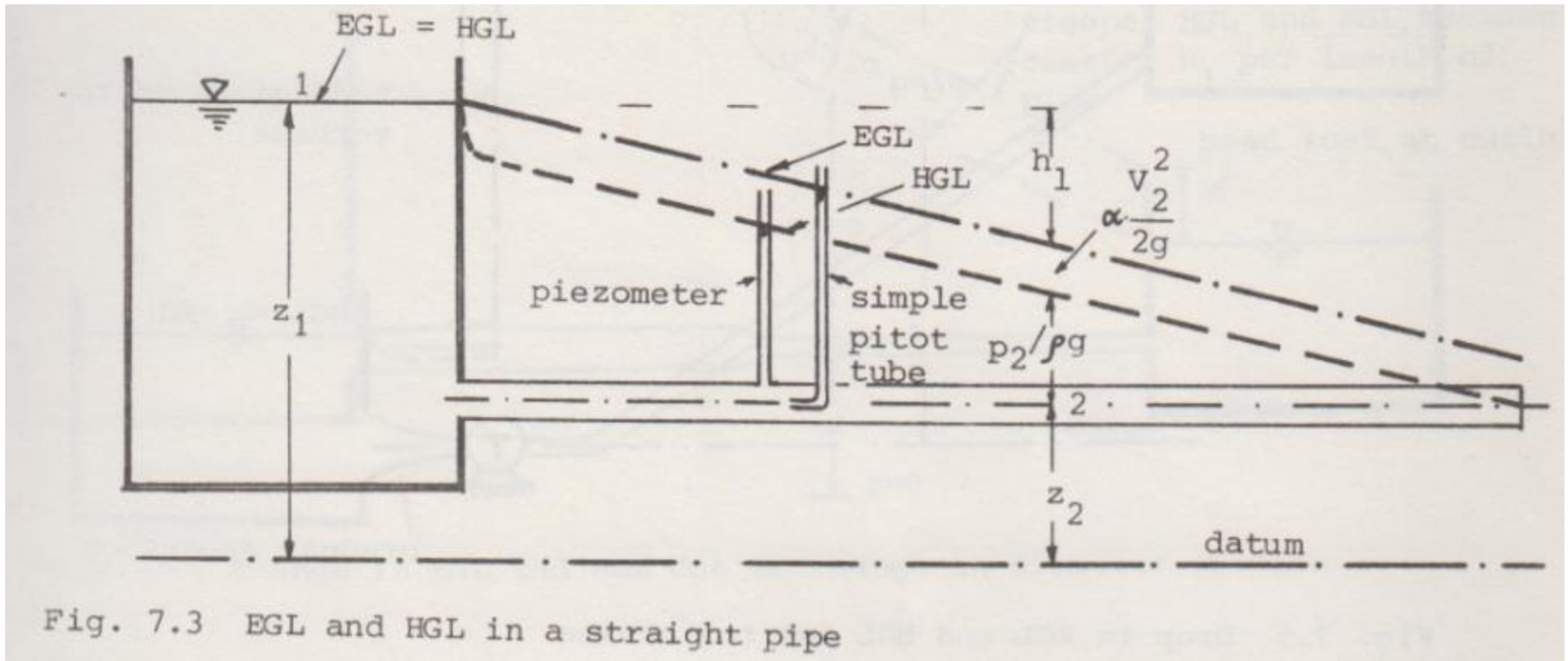

Fig. 7.3 EGL and HGL in a straight pipe

Some helpful hints for drawing hydraulic grade-lines and energy grade lines are enumerated below:

- a) By definition, the EGL is positioned above the HGL an amount  $\alpha \cdot (V^2/2g)$ . Thus, if the velocity is zero as in a lake or reservoir, the EGL and HGL will coincide with the liquid surface (see Fig. 7.3).
- b) Head loss  $h_p$  for flow in a pipe or channel always means that the EGL will slope downward in the direction of flow (Fig. 7.3). The only exception to this rule occurs when a pump supplies energy (and pressure) to the flow. Then an abrupt rise in the EGL (and the HGL) occurs from the upstream side to the downstream side of the pump (see Fig. 7.4). In this figure the pipe diameter is constant. Therefore, according to the continuity equation,  $V_1 = V_2 = V_3 = V_4 = V$ . Moreover, the HGL also rises an amount  $h_p$  at the pump.

c) A turbine takes energy abruptly out of the flow. Then the EGL and HGL will drop abruptly as in Fig. 7.5. The figure also shows that much of the kinetic energy can be converted to pressure if there is a gradual expansion such as at the outlet. Thus the head loss at the outlet is reduced, making the turbine installation more efficient. If the outlet is an abrupt expansion as in Fig. 7.7, all the kinetic energy is lost. Thus the EGL will drop an amount  $V^2/2g$  at the outlet.

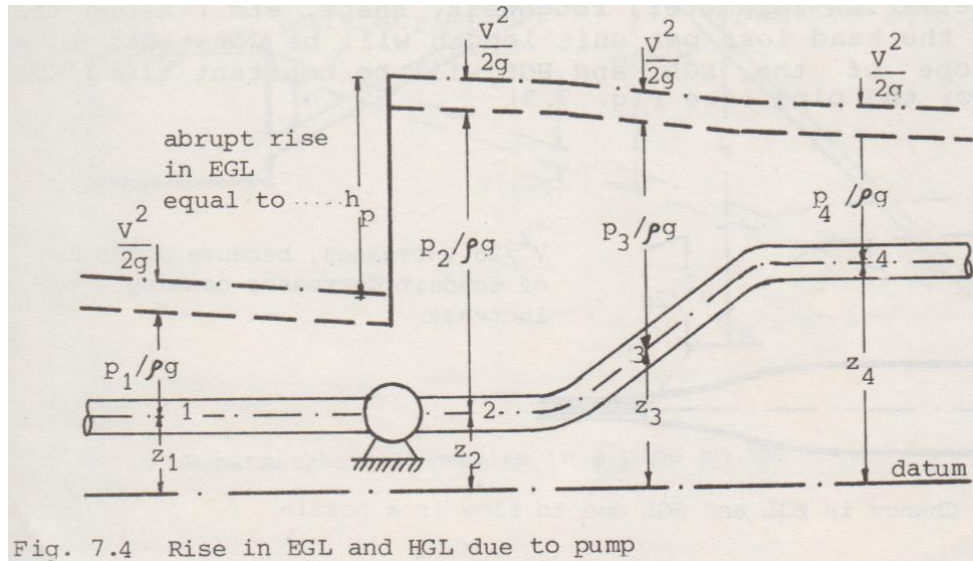
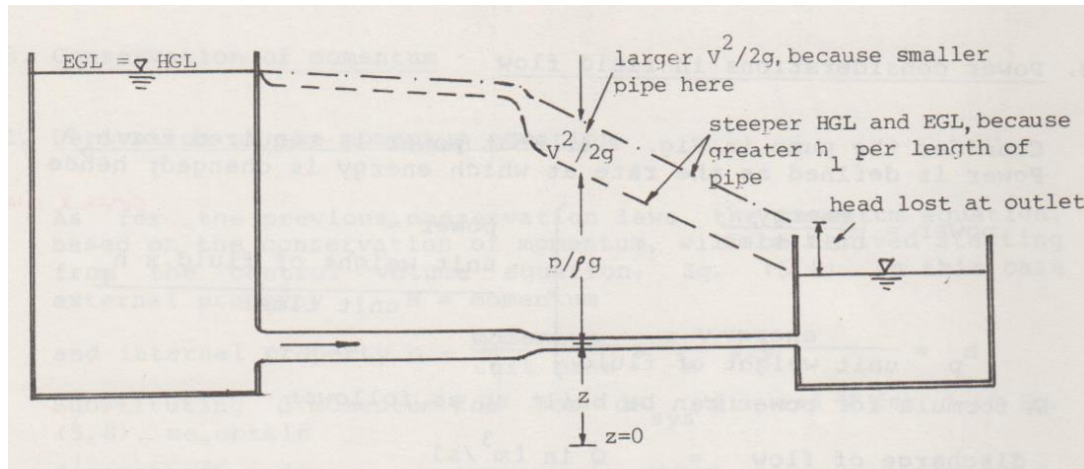

Fig. 7.4 Rise in EGL and HGL due to pump



Pump head is like what happened to Lazarus when Jesus resurrected him. His blood pressure rose from zero to a high value due to the pump (heart) just like the pump head (heart head)

d) In a pipe or channel where the pressure is zero, the HGL is coincident with the system, because  $p/\rho g = 0$  at these points. This fact can be used to locate the HGL at certain points, such as at the outlet end of a pipe, where the liquid discharges into the atmosphere or at the upstream end where the gauge pressure is zero at the reservoir surface (see Fig. 7.3).

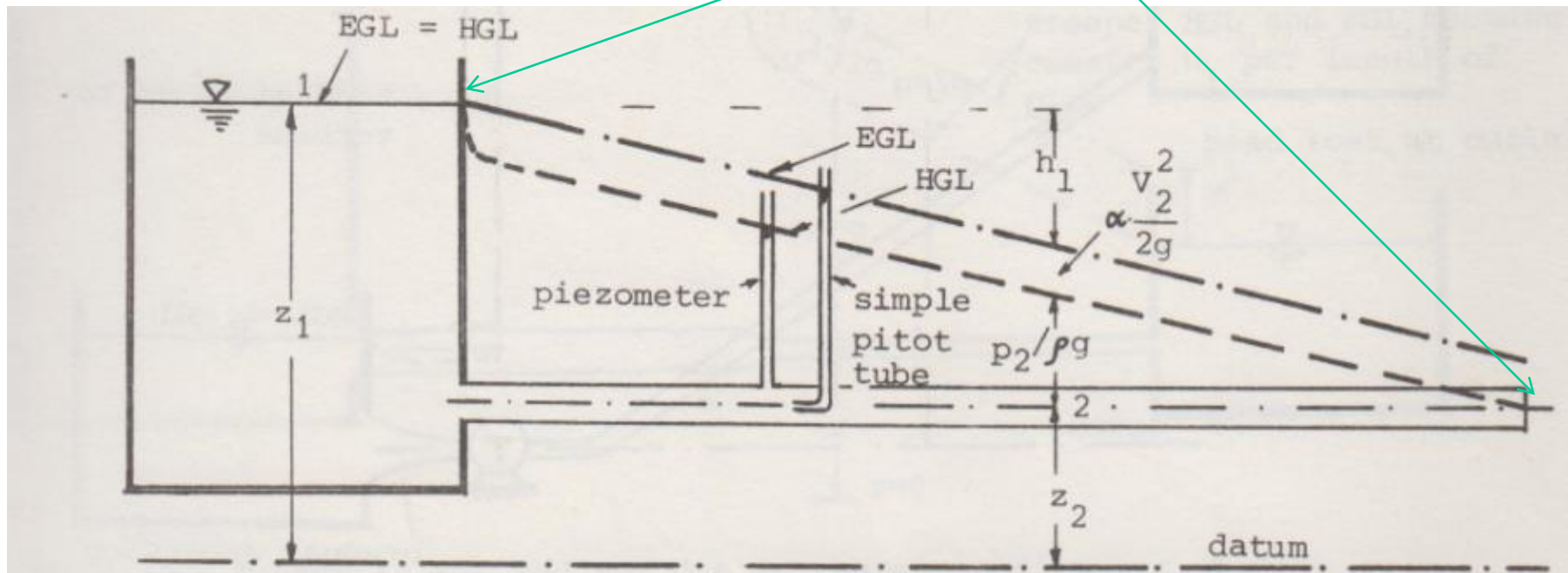
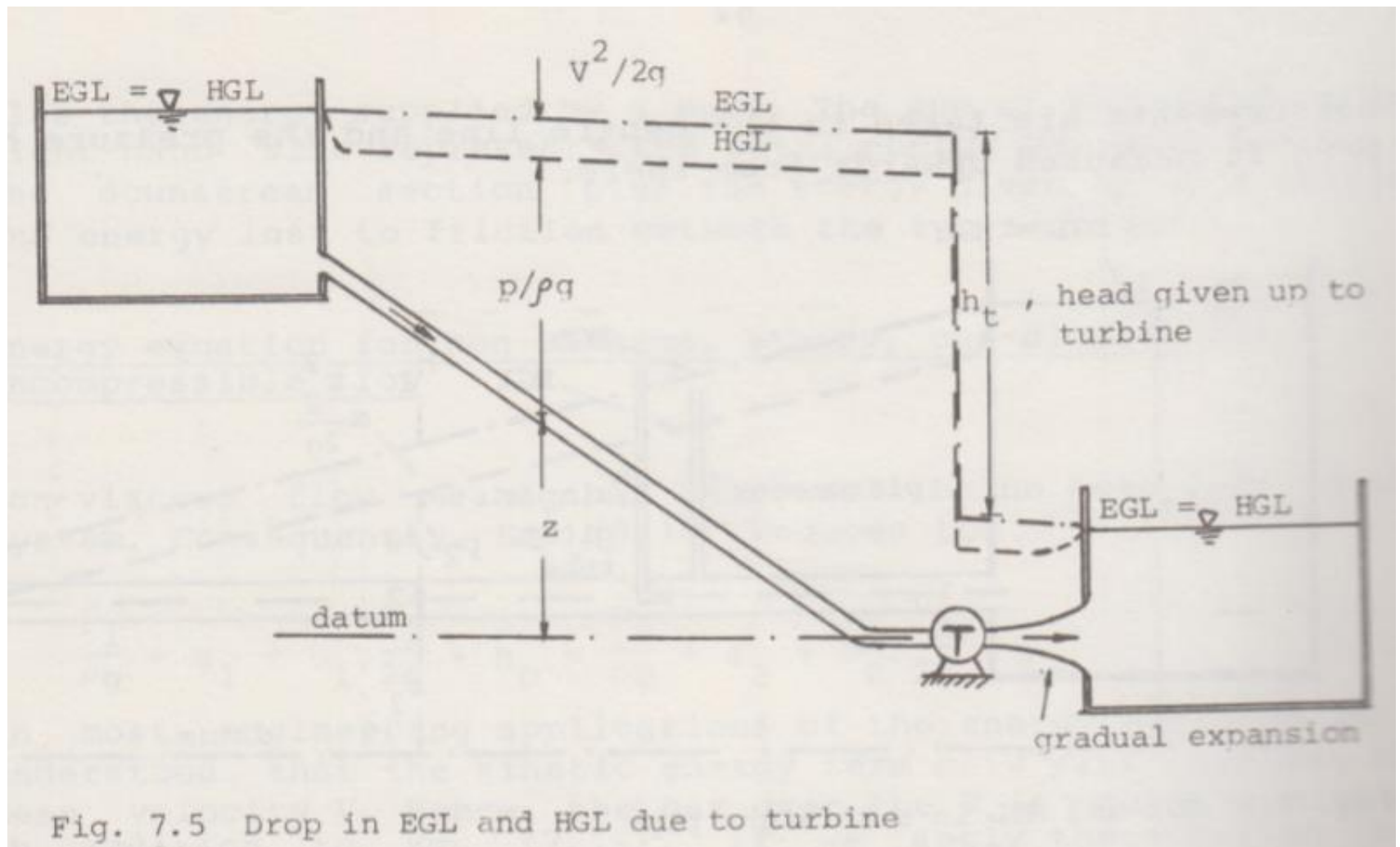

Fig. 7.3 EGL and HGL in a straight pipe



Turbine operates opposite to a pump. Some machines can be operated as a turbine or pump depending on the direction of flow of the water.

e) For steady flow in a pipe that has uniform physical characteristics (diameter, roughness, shape, etc.) along its length, the head loss per unit length will be constant. Thus the slope of the EGL and HGL will be constant along the length of the pipe (see Fig. 7.3)

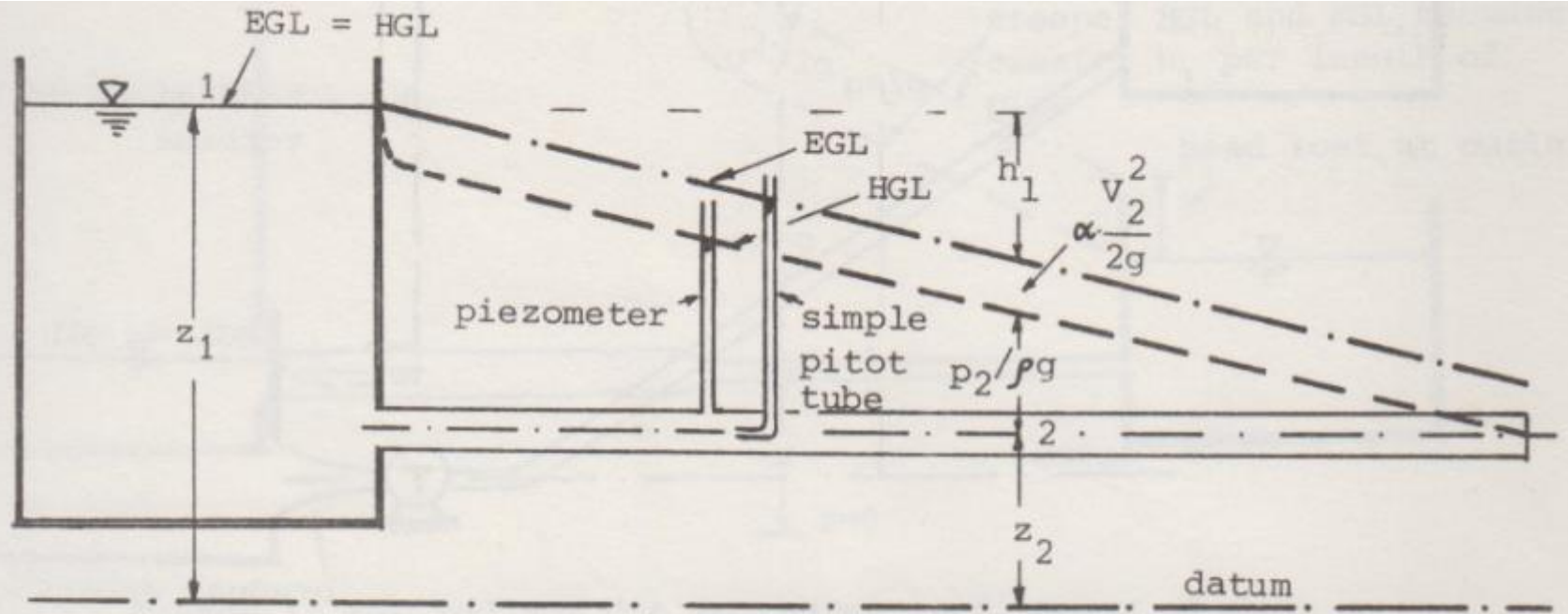

Fig. 7.3 EGL and HGL in a straight pipe

f) If a flow passage changes diameter, such as in a nozzle or by means of a change in pipe size, the velocity in there will also change. Hence, the distance between the EGL and the HGL will change (Fig. 7.6). In addition, the slope of the EGL will change, because the head loss per unit length will be larger in the conduit with the larger velocity (see Fig. 7.7). In Chapter 12 you will learn that  $h_f \propto V^2$ .

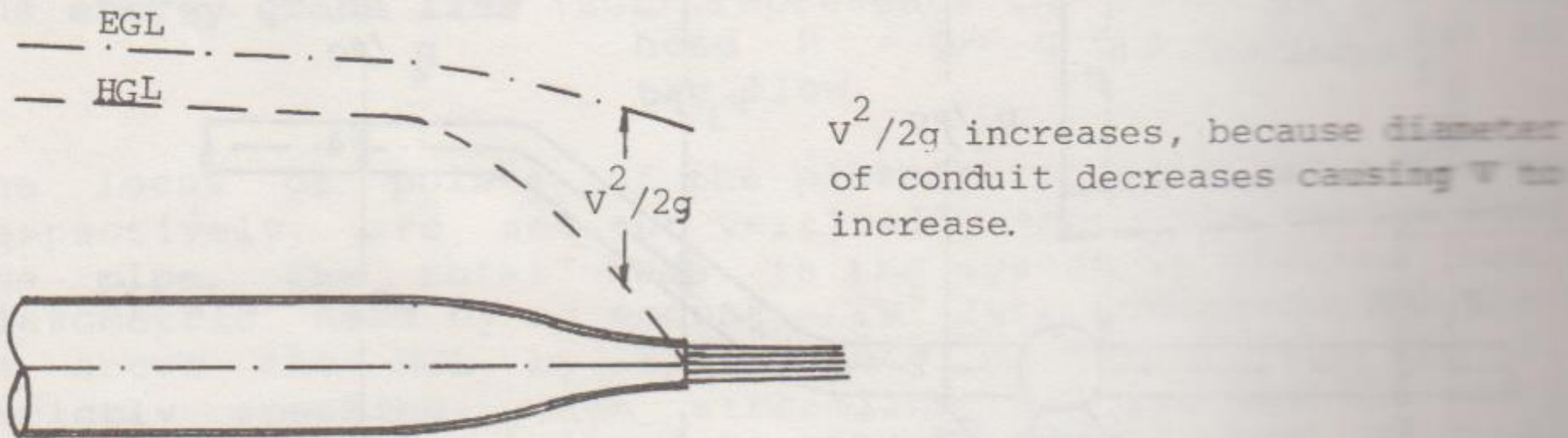

Fig. 7.6 Change in EGL and HGL due to flow in a nozzle

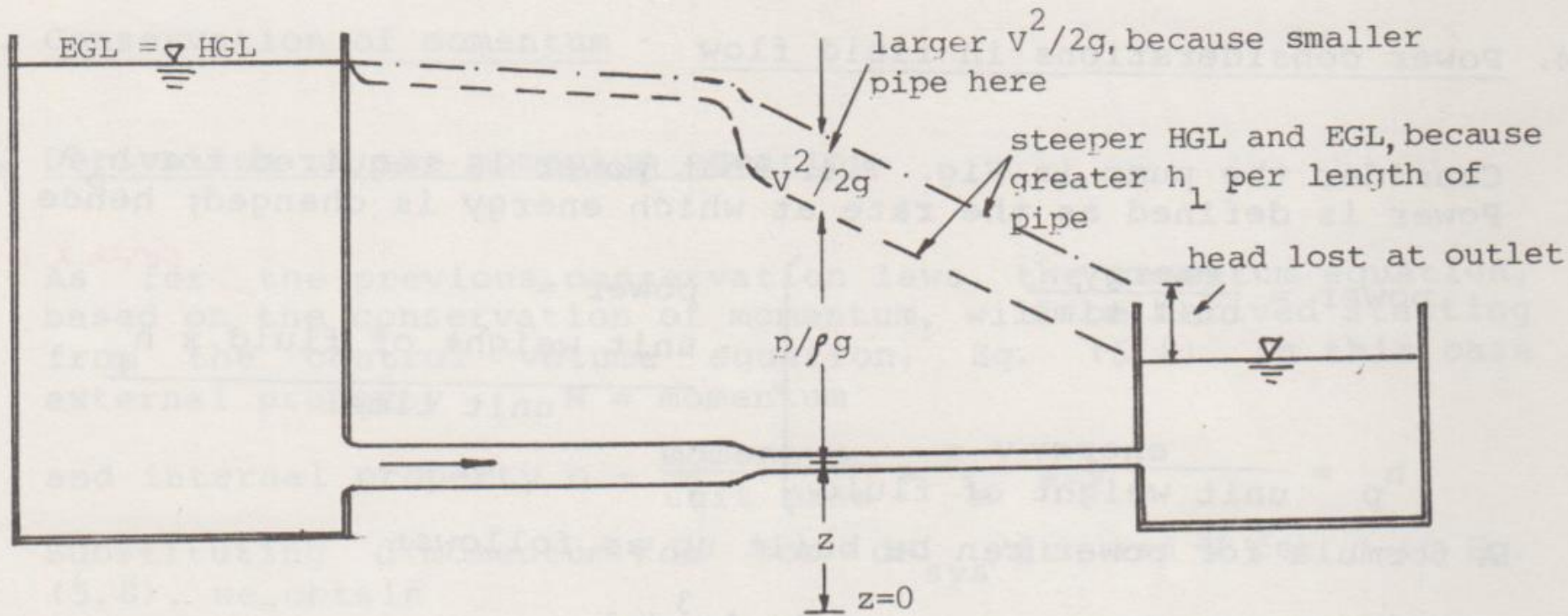

Fig. 7.7 Change in EGL and HGL due to change in diameter of pipe

g) If the HGL falls below the pipe, then  $p/\rho g$  is negative, thereby indicating sub-atmospheric pressure (see Fig. 7.8). By means of the drawn HGL, places where cavitation may occur, are easily determined. At sea level, cavitation of water will occur at appr.  $p/\rho g = -10$  m. For safety reasons, the minimum allowable pressure head in a pipe system is kept at  $-7.5$  m, thus  $p/\rho g > -7.5$  m.

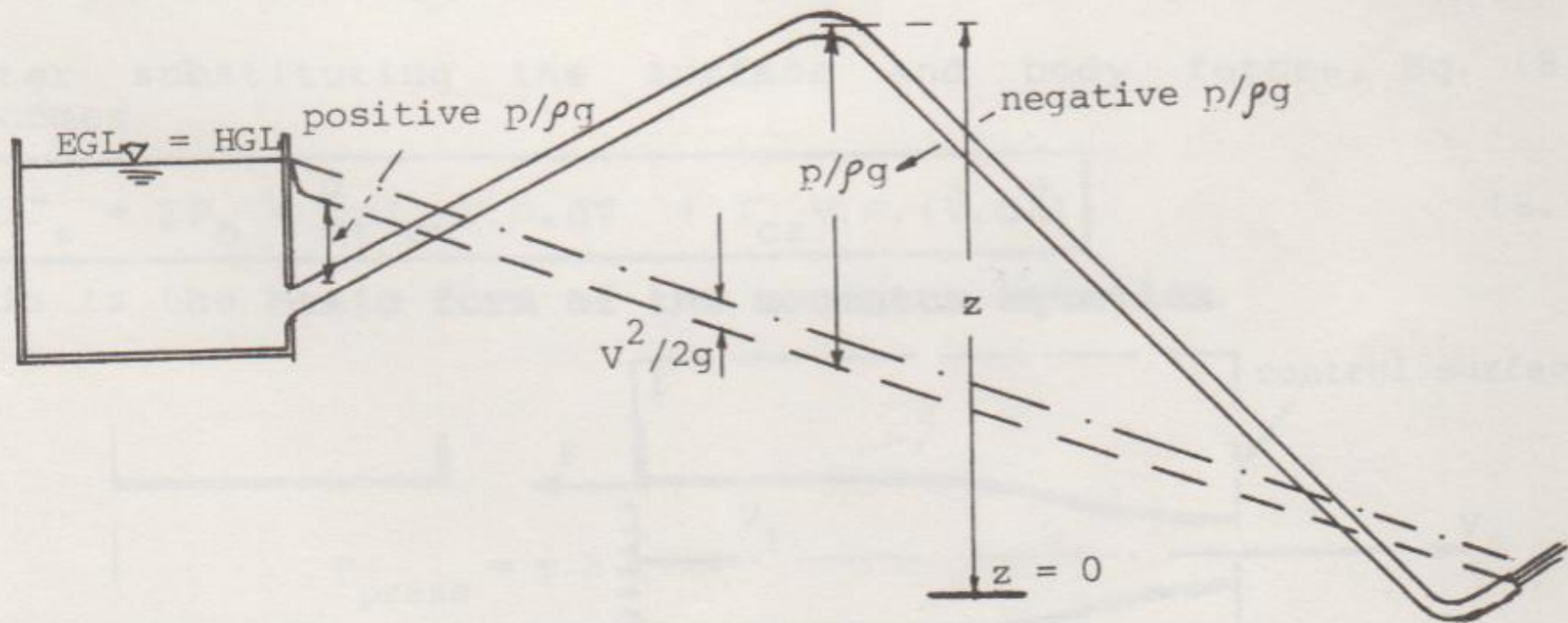

Fig. 7.8 Subatmospheric pressure in a pipe system.

## Power considerations in fluid flow

Consider the pump. What power is required for  $h_p$ ?

Power is defined as the rate at which energy is changed, hence

$$power = \frac{energy}{unit\ time}$$

$$= \text{unit weight of fluid} \times h_p / \text{unit time}$$

$$P = \frac{(\rho V)g}{t} h_p = \rho g Q h_p$$

$$P = \rho g Q h_p \quad \text{power required for } h_p$$

$$P = \rho g Q h_t \quad \text{power delivered to a turbine}$$

See Lecture 11  
for an example