

Fluid Mechanics CEE 3311

LECTURE 15

Ideal Flow

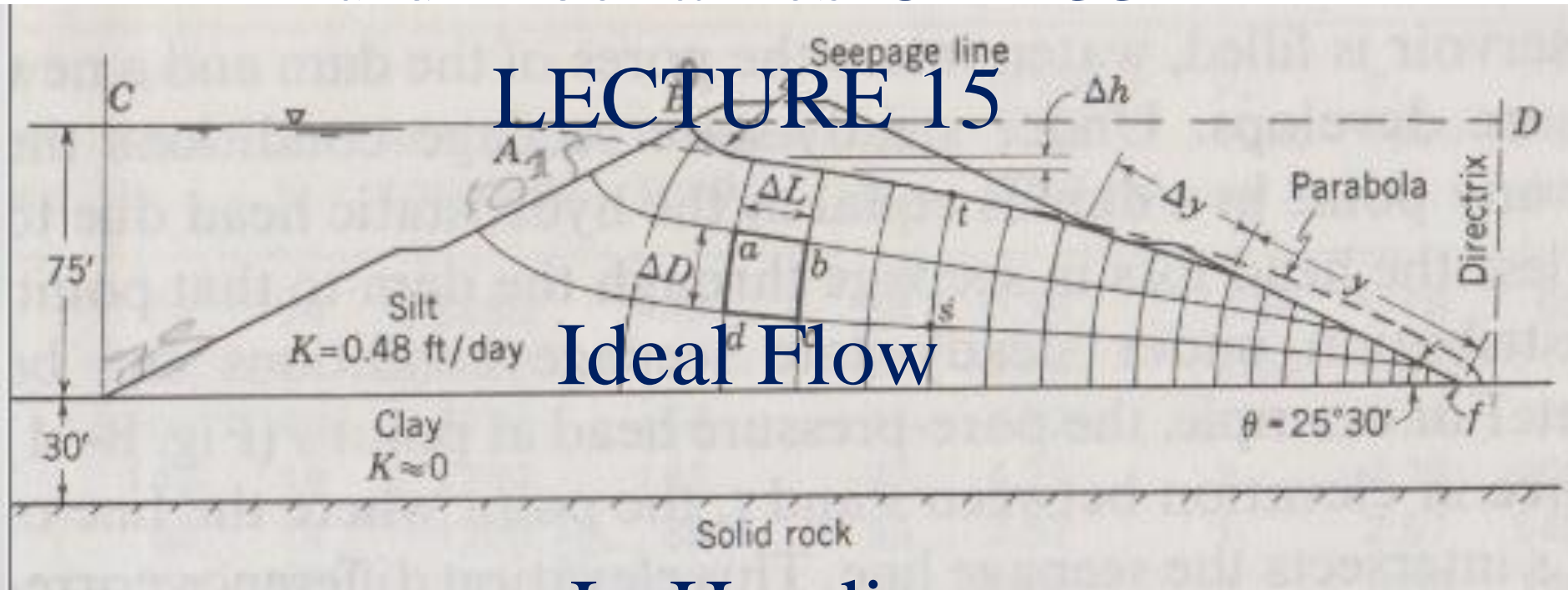

L. Handia

Introduction

- An ideal fluid may be defined as a fluid in which there is *no friction*; it is *inviscid* (its *viscosity is zero*).
- In this chapter we discuss various mathematical methods for *describing the flow of imaginary ideal (frictionless) fluids*. This subject is often referred to as *hydrodynamics*. It is a vast subject, so that the presentation here provides only an introduction, but it does give a good idea of the possibilities of a rigorous mathematical approach to flow problems.
- Even though such an approach does not consider all the real properties of fluids, the results *often closely approximate the behavior of real fluids*. This is because there are *numerous* situations in which *friction plays only a minor role*.
- For example, for fluids of low viscosity the viscosity affects only a thin region at the fluid boundaries. Turbulence and separation of the boundary layer occur far more readily with *decelerating flows*, and that *accelerating flows* generally have thin boundary layers. For such flows, mathematical analysis of ideal fluids yields results, often elegant, that can and do provide many useful and important insights into real fluid behavior.
- To concentrate on fundamentals, after the next section we shall limit our discussions to incompressible fluids and to two-dimensional, steady flow fields. It is rather interesting how the same methods can be applied to the flow of **a real fluid through porous media such as an earth dam and underground aquifers**. However, this will not be covered in this course but in Hydrology (CEE 4311) and Hydraulic Structures (CEE 5311) for CEE students.

DIFFERENTIAL EQUATION OF CONTINUITY

In Chap. 4 a very practical, but special, form of the equation of continuity was presented. For some purposes a more general three-dimensional form is desired. Also, in that chapter the concept of the flow net was explained

largely on an intuitive basis. To reach a more fundamental understanding of the mechanics of the flow net, it is necessary to consider the differential equations of continuity and irrotationality (Sec. 14.2) that give rise to the orthogonal network of streamlines and equipotential lines.

Aside from application to the flow net, the differential form of the continuity equation has an important advantage over the one-dimensional form that was derived in Sec. 4.7 in that it is perfectly general for two- or three-dimensional fluid space and for either steady or unsteady flow. Some of the equations in this section only will also be applicable to compressible flow.

DIFFERENTIAL EQUATION OF CONTINUITY

Figure 14.1 shows three coordinate axes x, y, z mutually perpendicular and fixed in space. Let the velocity components in these three directions be u, v, w , respectively. Consider now a small parallelepiped, having sides $\Delta x, \Delta y, \Delta z$. In the x direction the rate of mass flow into this box through the left-hand face is approximately $\rho u \Delta y \Delta z$, this expression becoming exact in the limit as the box is shrunk to a point. The corresponding rate of mass flow out of the box through the right-hand face is $\{\rho u + [\partial(\rho u)/\partial x] \Delta x\} \Delta y \Delta z$. Thus the net rate of mass flow into the box in the x direction is $-[\partial(\rho u)/\partial x] \Delta x \Delta y \Delta z$.

$$\frac{m}{t} = \frac{\rho V}{t} = \rho \Delta y \Delta z \frac{\Delta x}{t} = \rho u \Delta y \Delta z$$

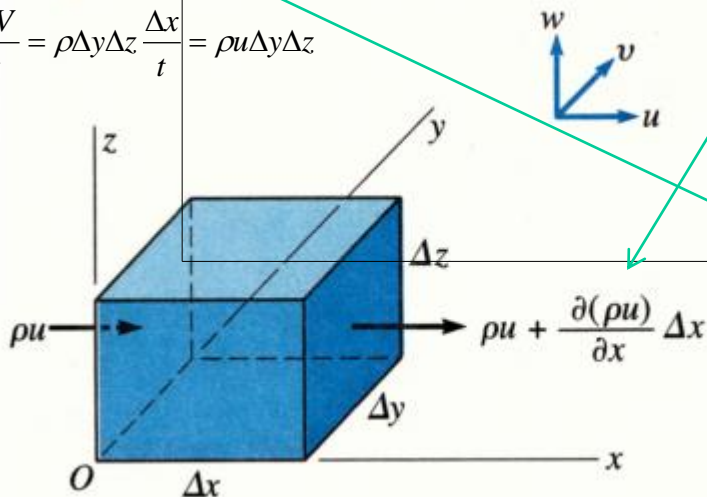

Figure 14.1

$$\frac{\partial m}{\partial t} = - \frac{\partial(\rho u)}{\partial x} \Delta x \Delta y \Delta z$$

$$\frac{d(\text{Mass})}{dt} = \frac{d}{dt} \int_{cv} \rho dV + \int_{cs} \rho \vec{v} dA$$

DIFFERENTIAL EQUATION OF CONTINUITY

Similar expressions may be obtained for the y and z directions. The sum of the rates of mass inflow in the three directions must equal the time rate of change of the mass in the box, or $(\partial\rho/\partial t) \Delta x \Delta y \Delta z$. Summing up, applying the limiting process, and dividing both sides of the equation by the volume of the parallelepiped, which is common to all terms, we get

$$\frac{\partial m}{\partial t} = \frac{\partial(\rho V)}{\partial t} = \frac{\partial\rho}{\partial t} \Delta x \Delta y \Delta z = -\frac{\partial(\rho u)}{\partial x} \Delta x \Delta y \Delta z - \frac{\partial(\rho v)}{\partial y} \Delta x \Delta y \Delta z - \frac{\partial(\rho w)}{\partial z} \Delta x \Delta y \Delta z$$

Divide by $\Delta x \Delta y \Delta z$ yields

Unsteady compressible flow:
$$-\frac{\partial(\rho u)}{\partial x} - \frac{\partial(\rho v)}{\partial y} - \frac{\partial(\rho w)}{\partial z} = \frac{\partial\rho}{\partial t} \tag{14.1}$$

which is the equation of continuity in its most general form. This equation as well as the other equations in this section are, of course, valid regardless of whether the fluid is a real one or an ideal one. If the flow is steady, ρ does not vary with time, but it may vary in space. Since $\partial(\rho u)/\partial x = \rho(\partial u/\partial x) + u(\partial\rho/\partial x)$, it follows that for steady flow the equation may be written as

Steady compressible flow:
$$u \frac{\partial\rho}{\partial x} + v \frac{\partial\rho}{\partial y} + w \frac{\partial\rho}{\partial z} + \rho \left(\frac{\partial u}{\partial x} + \frac{\partial v}{\partial y} + \frac{\partial w}{\partial z} \right) = 0 \tag{14.2}$$

DIFFERENTIAL EQUATION OF CONTINUITY

Steady
compressible flow:

$$u \frac{\partial \rho}{\partial x} + v \frac{\partial \rho}{\partial y} + w \frac{\partial \rho}{\partial z} + \rho \left(\frac{\partial u}{\partial x} + \frac{\partial v}{\partial y} + \frac{\partial w}{\partial z} \right) = 0 \quad (14.2)$$

In the case of an incompressible fluid ($\rho = \text{constant}$), whether the flow is steady or not, the equation of continuity becomes

Steady
incompressible flow:

$$\frac{\partial u}{\partial x} + \frac{\partial v}{\partial y} + \frac{\partial w}{\partial z} = 0 \quad (14.3)$$

DIFFERENTIAL EQUATION OF CONTINUITY

SAMPLE PROBLEM 14.1 Assuming ρ to be constant, do the following flows satisfy continuity? (a) $u = -2y$, $v = 3x$; (b) $u = 0$, $v = 3xy$; (c) $u = 2x$, $v = -2y$.

Solution

From Eq. (14.3): Continuity for incompressible fluids is satisfied if $\frac{\partial u}{\partial x} + \frac{\partial v}{\partial y} = 0$

$$\frac{\partial u}{\partial x} + \frac{\partial v}{\partial y} = 0$$

$$\frac{\partial u}{\partial x} + \frac{\partial v}{\partial y} + \frac{\partial w}{\partial z} = 0 \quad \text{Since it is 2 dimensional} \quad \frac{\partial u}{\partial x} + \frac{\partial v}{\partial y} = 0$$

$$(a) \quad \frac{\partial(-2y)}{\partial x} + \frac{\partial(3x)}{\partial y} = 0 + 0 = 0 \quad \text{Continuity is satisfied} \quad \mathbf{ANS}$$

$$(b) \quad \frac{\partial(0)}{\partial x} + \frac{\partial(3xy)}{\partial y} = 0 + 3x \neq 0 \quad \text{Continuity is not satisfied} \quad \mathbf{ANS}$$

$$(c) \quad \frac{\partial(2x)}{\partial x} + \frac{\partial(-2y)}{\partial y} = 2 - 2 = 0 \quad \text{Continuity is satisfied} \quad \mathbf{ANS}$$

Note: If (b) did indeed describe a flow field, the fluid must be compressible.

ROTATIONAL AND IRROTATIONAL FLOW

- Irrotational flow may be briefly described as flow in which each element of the moving fluid suffers no net rotation from one instant to the next, with respect to a given frame of reference.
- Another definition of irrotational flow: it is that type of flow in which the fluid particles when flowing along the streamlines do not rotate about their own axis
- Definition of rotational flow: opposite of above
- The classic example of irrotational motion (although not a fluid) is that of the carriages on a Ferris wheel used for amusement rides.



ROTATIONAL AND IRROTATIONAL FLOW

- Each carriage describes a circular path as the wheel revolves , but does not rotate *with respect to the earth*.



i.e., the carriage is *always* horizontal (with respect to the earth) so that people do not fall

ROTATIONAL AND IRROTATIONAL FLOW

- In irrotational flow, however, a fluid element may **deform** as shown in Fig 14.2a, where the axes of the element rotate equally toward or away from each other (like in a Ferris wheel). As long as the algebraic average rotation is zero, the motion is irrotational.

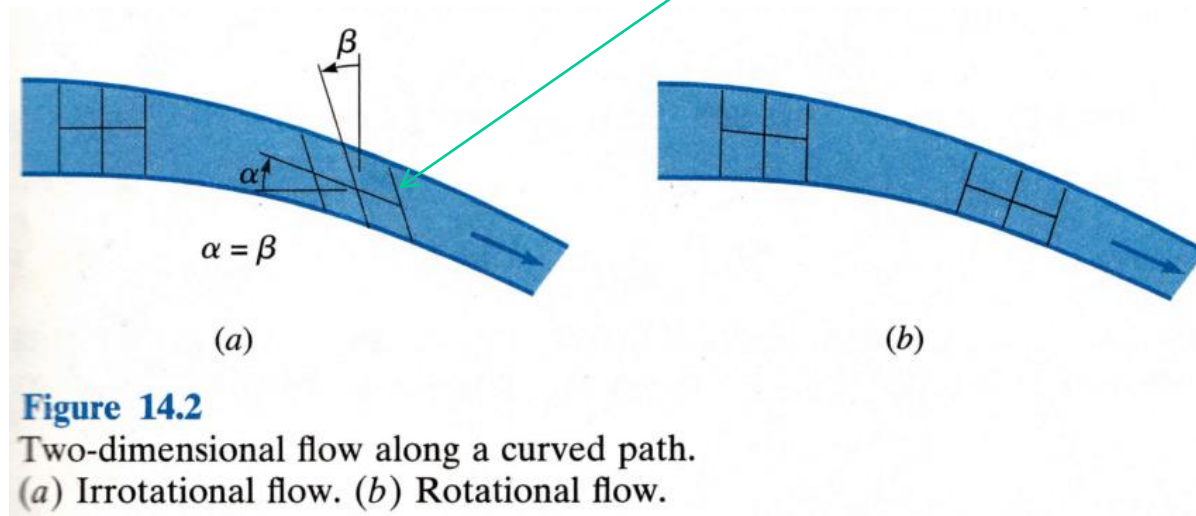

- In Fig 14.2b is depicted an example of rotational flow. In this case there is a net rotation of the fluid element. Actually, the deformation of the element in Fig. 14.2b is less than that of Fig. 14.2a.

ROTATIONAL AND IRROTATIONAL FLOW

- Let us now express the condition of irrotationality in mathematical terms.
- It will help to restrict the discussion at first to **two-dimensional** motion in the $x y$ plane

ROTATIONAL AND IRROTATIONAL FLOW

- Consider a small fluid element moving as depicted in Fig. 14.3a.

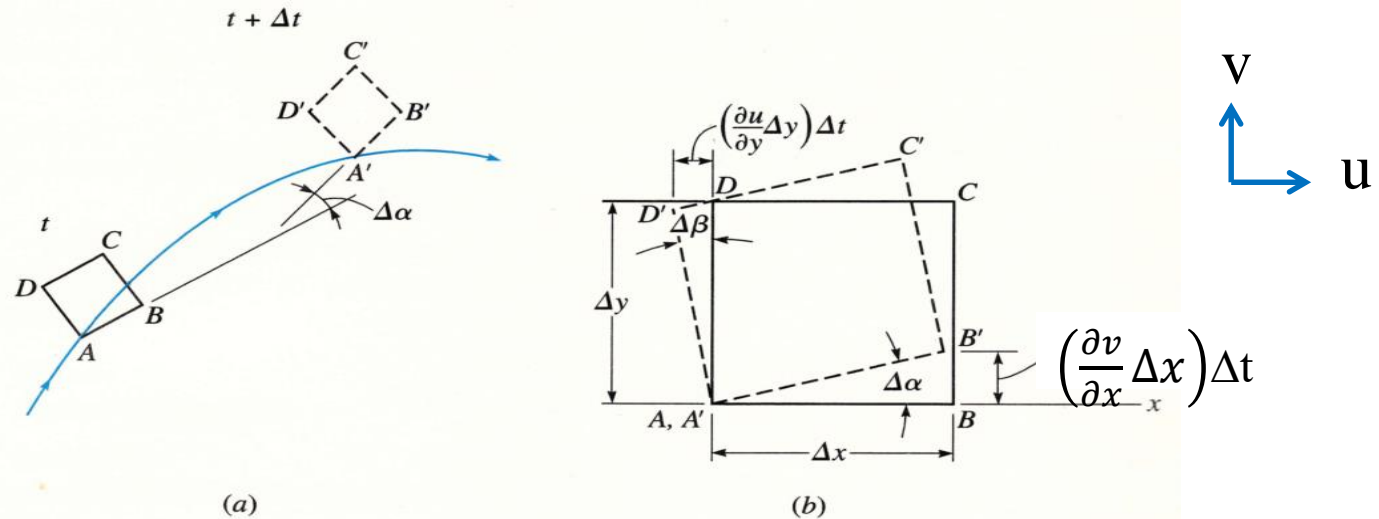

Figure 14.3

- During a short time interval Δt , the element moves from one position to another and in the process it deforms as indicated.
- Superimposing A' on A , defining an x axis along AB , and enlarging the diagram, we get Fig. 14.3b. u and v are velocities in x and y axes, respectively

ROTATIONAL AND IRROTATIONAL FLOW

- The angle $\Delta\alpha$ between AB and $A'B'$ can be expressed from Fig. 14.3b as

$$\Delta\alpha = \frac{BB'}{\Delta x} = \frac{[(\partial v/\partial x) \Delta x] \Delta t}{\Delta x} = \frac{\partial v}{\partial x} \Delta t$$

$\tan \Delta\alpha = \Delta\alpha$
when $\Delta\alpha$ is small

- Hence the *rate of rotation* of the edge of the element that was originally aligned with AB is

$$\omega_\alpha = \frac{\Delta\alpha}{\Delta t} = \frac{\partial v}{\partial x}$$

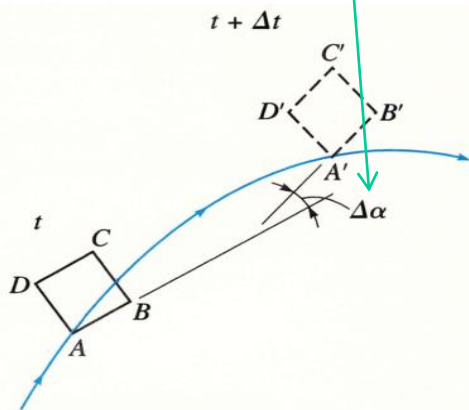

(a)

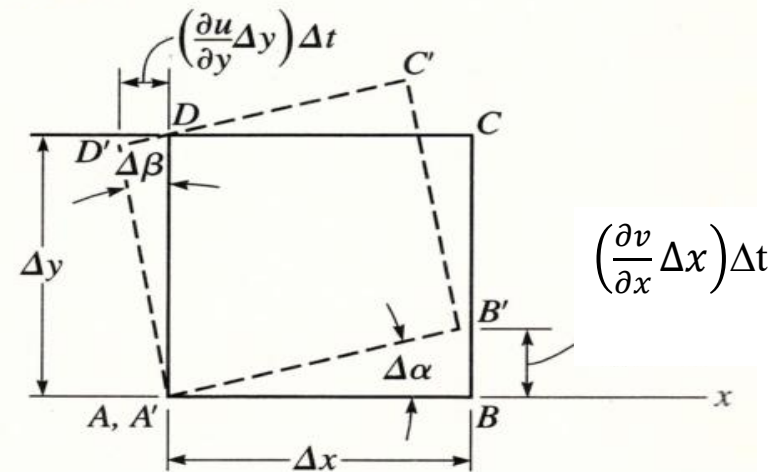

(b)

Figure 14.3

ROTATIONAL AND IRROTATIONAL FLOW

- Likewise
$$\Delta\beta = \frac{DD'}{\Delta y} = \frac{[-(\partial u/\partial y) \Delta y] \Delta t}{\Delta y} = -\frac{\partial u}{\partial y} \Delta t$$

- and the *rate of rotation* of the edge of the element that was originally aligned with AB is

$$\omega_\beta = \frac{\Delta\beta}{\Delta t} = -\frac{\partial u}{\partial y}$$

with the negative sign because +u is directed to the right.

- The rate of rotation of the element about the z axis is now defined to be ω_z , the average of ω_α and ω_β ; thus

$$\omega_z = \frac{1}{2} \left(\frac{\partial v}{\partial x} - \frac{\partial u}{\partial y} \right)$$

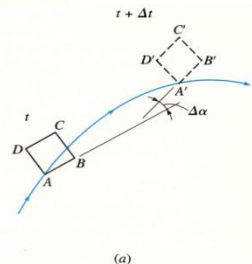
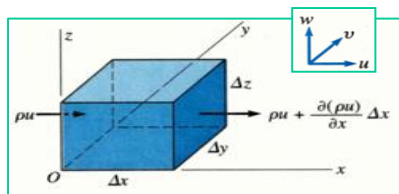
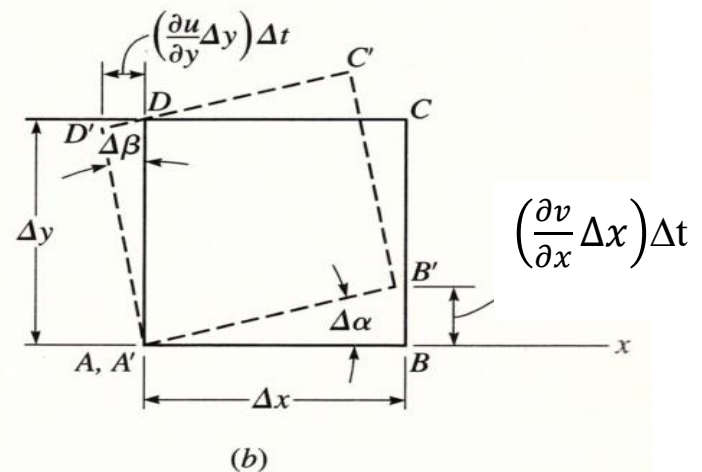

Figure 14.3



(b)

ROTATIONAL AND IRROTATIONAL FLOW

- But the criterion we originally stipulated for irrotational flow was that the rate of rotation be zero. Therefore we have

irrotational flow
in xy plane

$$\frac{\partial v}{\partial x} - \frac{\partial u}{\partial y} = 0$$

- In **three-dimensional** flow there are corresponding expressions for the components of angular-deformation rates about the x and y axes. Finally, for the general case, irrotational flow is defined to be that for which

$$\omega_x = \omega_y = \omega_z = 0$$

- In Slide 17, we shall see that the **primary significance of irrotational flow is that it is defined by a velocity potential.**

ROTATIONAL AND IRROTATIONAL FLOW

SAMPLE PROBLEM 14.2 Determine whether the following flows are rotational or irrotational: (a) $u = -2y$, $v = 3x$; (b) $u = 0$, $v = 3xy$; (c) $u = 2x$, $v = -2y$.

Solution

Using Eq. (14.7):

for irrotational flow

$$\frac{\partial v}{\partial x} - \frac{\partial u}{\partial y} = 0$$

$$(a) \frac{\partial(3x)}{\partial x} - \frac{\partial(-2y)}{\partial y} = 3 + 2 \neq 0$$

Flow is rotational **ANS**

$$(b) \frac{\partial(3xy)}{\partial x} - \frac{\partial(0)}{\partial y} = 3y - 0 \neq 0$$

Flow is rotational **ANS**

$$(c) \frac{\partial(-2y)}{\partial x} - \frac{\partial(2x)}{\partial y} = 0 - 0 = 0$$

Flow is irrotational **ANS**

THE STREAM FUNCTION

The stream function ψ (psi), based on the continuity principle, is a mathematical expression that *describes a flow field*. In Fig. 14.6 are shown two adjacent streamlines of a two-dimensional flow field. Let $\psi(x, y)$ represent the streamline nearest the origin. Then $\psi + d\psi$ is representative of the second streamline. Since there is no flow across a streamline, we can let ψ be indicative of the flow carried through the area from the origin O to the first streamline. And thus $d\psi$ represents the flow carried between the two streamlines of Fig. 14.6. From continuity, referring to the triangular fluid element of Fig. 14.6, we see that for an incompressible fluid

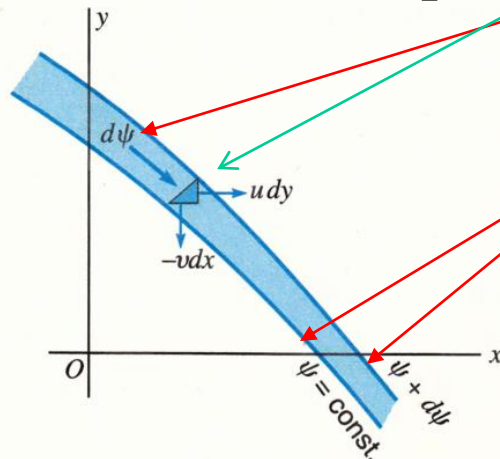

Figure 14.6
Stream function.

$$d\psi = -v dx + u dy \quad 14.14$$

-ve because flow in opposite direction to y-axis

The total derivative $d\psi$ may also be expressed as

$$d\psi = \frac{\partial \psi}{\partial x} dx + \frac{\partial \psi}{\partial y} dy \quad 14.15$$

THE STREAM FUNCTION

- Comparing these last two equations, we note that

$$u = \frac{\partial \psi}{\partial y} \quad \text{and} \quad v = -\frac{\partial \psi}{\partial x} \quad 14.16$$

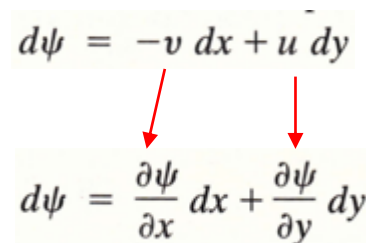
$$d\psi = -v dx + u dy$$

$$d\psi = \frac{\partial \psi}{\partial x} dx + \frac{\partial \psi}{\partial y} dy$$

- Thus, if ψ can be expressed as a function of x and y , we can find the velocity components (u and v) at any point of a two-dimensional flow field by application of Eqs. (14.16).
- Conversely, if u and v are expressed as functions of x and y , we can find ψ by integrating Eq. (14.14). $d\psi = -v dx + u dy$ 14.14
- However, it should be noted that since the derivation of ψ is based on the principle of continuity, it is **necessary** that *continuity be satisfied for the stream function to exist*.
- Also, since vorticity $\xi = \frac{\partial v}{\partial x} - \frac{\partial u}{\partial y}$ (the circulation per unit of enclosed area) was not considered in the derivation of ψ , *the flow need not be irrotational for the stream function to exist*.

THE STREAM FUNCTION

- The equation of continuity ($\frac{\partial u}{\partial x} + \frac{\partial v}{\partial y} + \frac{\partial w}{\partial z} = 0$ (14.3))

$$\frac{\partial u}{\partial x} + \frac{\partial v}{\partial y} = 0$$

may be expressed in terms of ψ by substituting the expressions for u and v from Eqs. (14.16); doing so, we get $u = \frac{\partial \psi}{\partial y}$ and $v = -\frac{\partial \psi}{\partial x}$ (14.16)

$$\frac{\partial}{\partial x} \left(\frac{\partial \psi}{\partial y} \right) - \frac{\partial}{\partial y} \left(\frac{\partial \psi}{\partial x} \right) = 0, \quad \text{or} \quad \frac{\partial^2 \psi}{\partial x \partial y} = \frac{\partial^2 \psi}{\partial y \partial x}$$

which shows that, if $\psi = \psi(x, y)$, the derivatives taken in either order give the same result and that *a flow described by a stream function automatically satisfies the continuity equation* (since

$$\frac{\partial u}{\partial x} + \frac{\partial v}{\partial y} = 0 \quad \text{is satisfied})$$

BASIC FLOW FIELDS

In this section we shall discuss one of the basic flow fields that is commonly encountered. Though these flow fields imply an ideal fluid, they **closely depict** the flow of a *real* fluid *outside the zone of viscous influence* provided there is no separation of the flow from the boundaries (see Sec. 4.10). The simplest of all flows is that in which the streamlines are straight, parallel, and evenly spaced as indicated in Fig. 14.7. In this case $v = 0$ and $u = \text{constant}$. Thus, from Eq. (14.14), $d\psi = u dy$, and hence $\psi = Uy$, where U is the velocity of flow. If the distance between streamlines is a , the values of ψ for the streamlines are as indicated in Fig. 14.7. e.g., $\psi = Uy = 3Ua$ when $y = 3a$

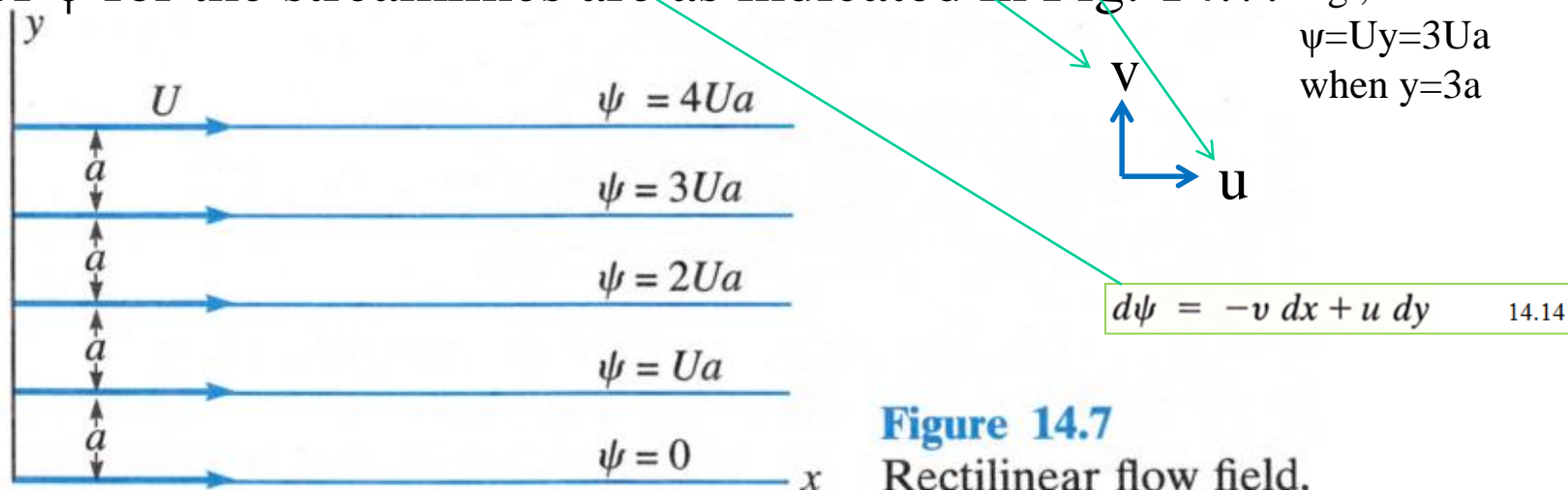

Figure 14.7
Rectilinear flow field.

VELOCITY POTENTIAL

Let us define the potential

$$-d\phi = u dx + v dy \quad 14.20$$

Mathematically, this is termed an “exact” differential, and therefore the function $\phi(x, y)$ exists, if

$$\frac{\partial u}{\partial y} = \frac{\partial v}{\partial x} \quad 14.21$$

14.21 will be proved in 14.25

But the total derivative is defined to be

$$d\phi = \frac{\partial \phi}{\partial x} dx + \frac{\partial \phi}{\partial y} dy \quad 14.22$$

By comparing (14.20) with (14.22) we see that in Cartesian coordinates

$$u = -\frac{\partial \phi}{\partial x} \quad \text{and} \quad v = -\frac{\partial \phi}{\partial y} \quad 14.23$$

The use of a minus sign in Eq. (14.20) led to the minus signs in the expressions (14.23), which indicate that the *velocity potential decreases in the direction of flow*, i.e., *flow moves from areas of high potential (head) to low potential (head)*. E.g., the Zambezi River flows from Kaleni Hills (potential or $z = 1,460\text{m amsl}$) to the Indian Ocean ($z = 0$). Some authors prefer the opposite, and so change these signs e.g. Darcy’s formula $-v = K\phi = K \frac{dh}{dx}$ for flow through porous media (such as groundwater & earth dams)

VELOCITY POTENTIAL

For two-dimensional flow, ϕ with conditions (14.23) is termed the *velocity potential* function. In polar coordinates, the corresponding expressions are

$$v_r = -\frac{\partial\phi}{\partial r} \quad \text{and} \quad v_t = -\frac{1}{r} \frac{\partial\phi}{\partial\theta} \quad (14.24)$$

Differentiating Eqs. (14.23), we get

$$u = -\frac{\partial\phi}{\partial x} \quad \text{and} \quad v = -\frac{\partial\phi}{\partial y} \quad \frac{\partial u}{\partial y} = -\frac{\partial^2\phi}{\partial y \partial x} \quad \text{and} \quad \frac{\partial v}{\partial x} = -\frac{\partial^2\phi}{\partial x \partial y} \quad 14.25$$
$$\frac{\partial u}{\partial y} = \frac{\partial v}{\partial x}$$

Since the right-hand sides of these two last quantities are equal, this satisfies the requirement (14.21), which, from equation of vorticity $\xi = \frac{\partial v}{\partial x} - \frac{\partial u}{\partial y}$, proves that $\xi = 0$. Thus it follows that *if a flow is irrotational*

($\xi = 0$) *then a velocity potential exists, and vice versa.* Because of the existence of a velocity potential, such flow is often referred to as *potential flow*.

VELOCITY POTENTIAL

The rotation of fluid particles requires the application of torque (defined as a measure of how much a force acting on an object causes that object to rotate), which in turn depends on shearing forces. Such forces are possible only in a viscous fluid. In inviscid (or ideal) fluids there can be no shears and hence no torques.

If we substitute Eqs. (14.23) into the continuity Eq. (14.3), we get

$$u = -\frac{\partial \phi}{\partial x} \quad \text{and} \quad v = -\frac{\partial \phi}{\partial y}$$

$$\frac{\partial^2 \phi}{\partial x^2} + \frac{\partial^2 \phi}{\partial y^2} = 0$$

14.26

This is the **Laplace equation**, named after the French mathematician and astronomer, Marquis Pierre Simon de Laplace (1749-1827). It is possibly the best known of all partial differential equations, important also in solid mechanics and thermodynamics. For fluids, *if a function ϕ satisfies Laplace's equation, the resulting flow must be irrotational.*

$$\frac{\partial u}{\partial x} + \frac{\partial v}{\partial y} + \frac{\partial w}{\partial z} = 0$$

ORTHOGONALITY OF STREAMLINES AND EQUIPOTENTIAL LINES

From Eqs. (14.14) and (14.20) we have

$$d\psi = -v dx + u dy$$

$$d\phi = -u dx - v dy$$

and

Along a streamline, $\psi = \text{constant}$, so $d\psi = 0$, and from the first equation (14.14) we get $dy/dx = v/u$. *Along an equipotential line*, $\phi = \text{constant}$, so $d\phi = 0$, and from the second equation (14.20) we get $dy/dx = -u/v$. *Geometrically*, this tells us that the streamlines and equipotential lines are **orthogonal**, or *everywhere perpendicular to each other*. As a result, the stream function and the velocity potential are known as **conjugate functions**.

ORTHOGONALITY OF STREAMLINES AND EQUIPOTENTIAL LINES

The equipotential lines $\phi = C$, and the streamlines $\psi = K$, where the C and the K have equal increments between adjacent lines, form a *network of intersecting perpendicular lines* that is called a **flow net** (Fig. 14.10).

The small quadrilaterals must evidently become squares as their size approaches zero, if the x and y scales are the same (e.g., length: head (y axis) & length (x axis)), since from Eqs. (14.16) and (14.23) $|u| = |\delta\phi/\delta x| = |\delta\psi/\delta y|$, or for finite increments $|\Delta\phi/\Delta x| = |\Delta\psi/\Delta y|$.

The difference in value of the stream function between adjacent streamlines is called the **strength** of the stream tube bounded by two streamlines, and it represents the two-dimensional flow through the tube.

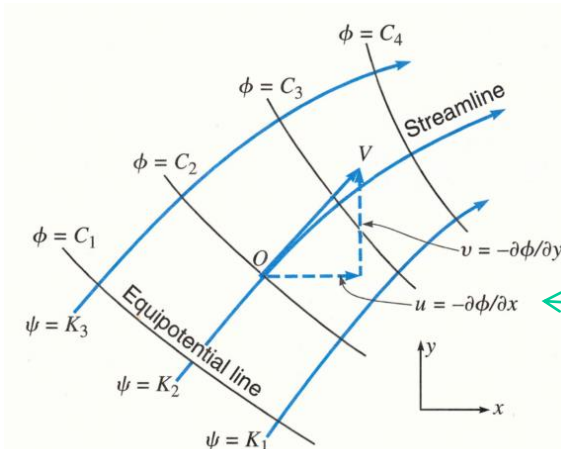

Figure 14.10
Flow net.

$$u = \frac{\partial\psi}{\partial y} \quad \text{and} \quad v = -\frac{\partial\psi}{\partial x} \quad 14.16$$

$$u = -\frac{\partial\phi}{\partial x} \quad \text{and} \quad v = -\frac{\partial\phi}{\partial y} \quad 14.23$$

ORTHOGONALITY OF STREAMLINES AND EQUIPOTENTIAL LINES

- Stream functions can exist in the absence of irrotationality, and potential functions are possible even though continuity is not satisfied.
- But, since *lines of ϕ and ψ are required to form an orthogonal network, a flow net can only exist if irrotationality* (the condition for the existence of ϕ) *and continuity* (the condition for the existence of ψ) *are satisfied*. The Laplace equation was derived assuming the existence of velocity potentials and the satisfaction of continuity. Thus, if a given flow satisfies the Laplace equation, a flow net can be constructed for that flow.
- Because of irrotationality requirement such potential flows are usually those of ideal fluids.

ORTHOGONALITY OF STREAMLINES AND EQUIPOTENTIAL LINES

Example of an earth dam

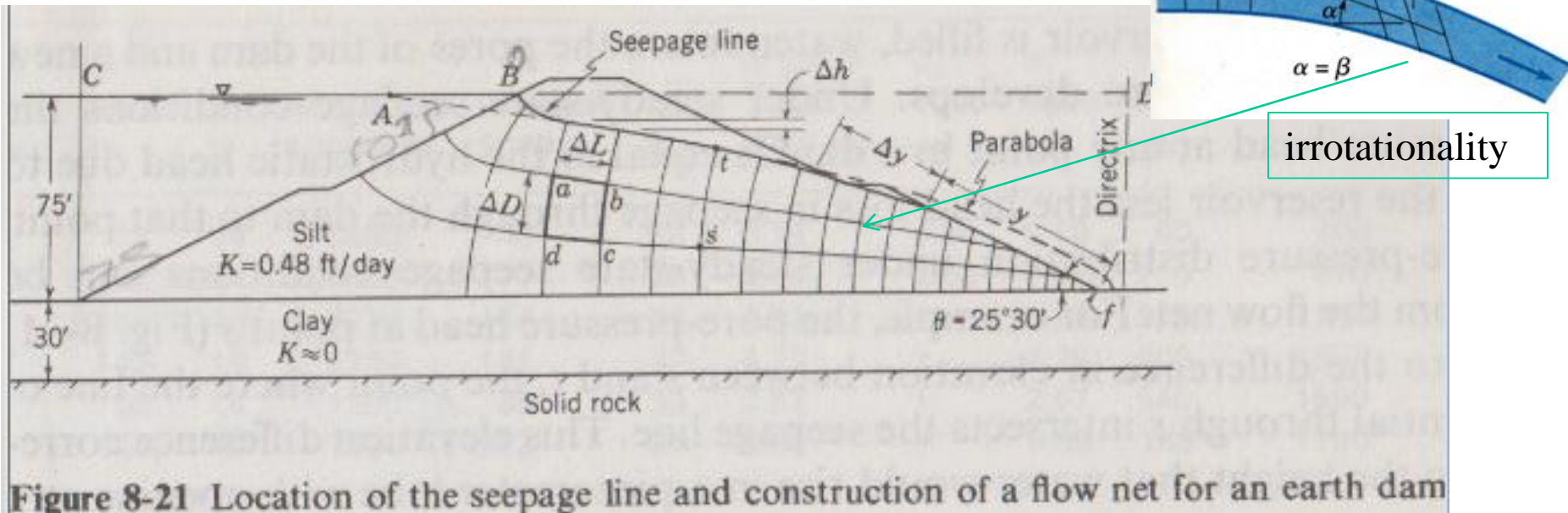

irrotationality

The small quadrilaterals must evidently become squares as their size approaches zero, if the x and y scales are the same (e.g., length: head (y axis) & length (x axis)), since Eqs. (14.16) and (14.23) $|u| = |\delta\phi/\delta x| = |\delta\psi/\delta y|$, or for finite increments $|\Delta\phi/\Delta x| = |\Delta\psi/\Delta y|$.

The difference in value of the stream function between adjacent streamlines is called the **strength** of the stream tube bounded by two streamlines, and it represents the two-dimensional flow through the tube.

ORTHOGONALITY OF STREAMLINES AND EQUIPOTENTIAL LINES

SAMPLE PROBLEM 14.5 An incompressible flow is defined by $u = 2x$ and $v = -2y$. Find the stream function and potential function for this flow and plot the flow net.

Solution

Check continuity:

Eq. (14.3):
$$\frac{\partial u}{\partial x} + \frac{\partial v}{\partial y} = 2 - 2 = 0$$

Hence continuity is satisfied, and it is possible for a stream function to exist:

Eq. (14.14):
$$d\psi = -v dx + u dy = 2y dx + 2x dy$$

Integrating:
$$\psi = 2xy + C_1 \quad \mathbf{ANS}$$

ORTHOGONALITY OF STREAMLINES AND EQUIPOTENTIAL LINES

Check to see if the flow is irrotational:

Eq. (14.7):
$$\frac{\partial v}{\partial x} - \frac{\partial u}{\partial y} = 0 - 0 = 0$$

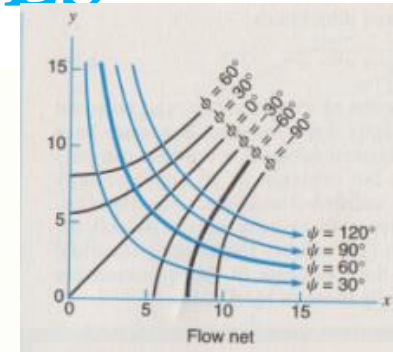

Hence $\xi = 0$, the flow is irrotational, and a potential function exists:

Eq. (14.20):
$$d\phi = -u dx - v dy = -2x dx + 2y dy$$

Integrating:
$$\phi = -(x^2 - y^2) + C_2 \quad \text{ANS}$$

Letting $\psi = 0$ and $\phi = 0$ pass through the origin, we get $C_1 = C_2 = 0$.

The location of lines of equal ψ can be found by substituting values of ψ into the expression $\psi = 2xy$. Thus for $\psi = 60$, $x = 30/y$. This line is plotted (in the upper right-hand quadrant) on the adjoining figure. In a similar fashion lines of equal potential can be plotted. For example, for $\phi = -60$ we have $-(x^2 - y^2) = -60$ and $x = \pm\sqrt{y^2 + 60}$. This line is also plotted on the figure. The flow net depicts **flow in a corner**. Mathematically the net will plot symmetrically in all four quadrants.

ORTHOGONALITY OF STREAMLINES AND EQUIPOTENTIAL LINES

The location of lines of equal ψ can be found by substituting values of ψ into the expression $\psi = 2xy$. Thus for $\psi = 60$, $x = 30/y$. This line is plotted (in the upper right-hand quadrant) on the adjoining figure. In a similar fashion lines of equal potential can be plotted. For example, for $\phi = -60$ we have $-(x^2 - y^2) = -60$ and $x = \pm\sqrt{y^2 + 60}$. This line is also plotted on the figure. The flow net depicts *flow in a corner*. Mathematically the net will plot symmetrically in all four quadrants.

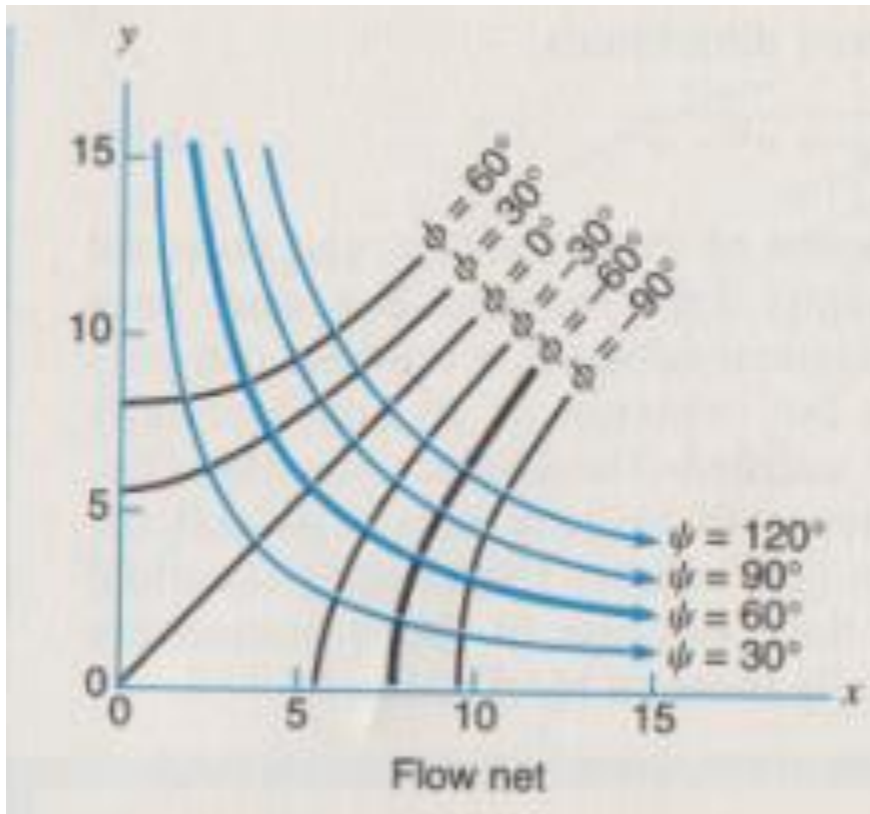

USE AND LIMITATIONS OF FLOW NET

4.10

USE AND LIMITATIONS OF FLOW NET

Although the flow net is based on an ideal frictionless fluid, it may be applied to the flow of a real fluid within certain limits. Such limits are dictated by the extent to which the real fluid is affected by factors which the ideal-fluid theory neglects. The principal factor of this type is fluid friction.

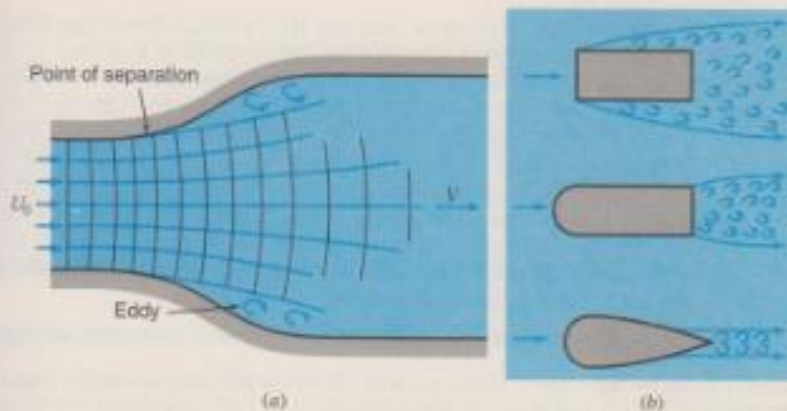

Figure 4.13
Separation in diverging flow. (a) Eddy formation in a diverging channel.
(b) Turbulent wakes.

The viscosity effects of a real fluid are most pronounced at or near a solid boundary and diminish rapidly with distance from the boundary. Hence, for an airplane or a submerged submarine, the fluid may be considered as frictionless, except when very close to the object. The flow net always indicates a velocity next to a solid boundary, whereas a real fluid must have zero velocity adjacent to a wall. The region in which the velocity is so distorted, however, is confined to a relatively thin layer called the **boundary layer** (Secs. 8.7–8.9 and 9.2–9.4), outside of which the real fluid behaves very much like the ideal fluid.

The effect of the boundary friction is minimized when the streamlines are converging, but in a diverging flow there is a tendency for the streamlines not to follow the boundaries if the rate of divergence is too great. In a sharply diverging flow, such as is shown schematically in Fig. 4.13, there may be a **separation** of the boundary layer from the wall, resulting in **eddies** and even reverse flow in that region (Fig. 9.8). The flow is badly disturbed in such a case, and the flow net may be of limited value.

A practical application of the flow net may be seen in the flow around a body, as shown in Fig. 4.12. An example of this is the upstream portion of a bridge pier below the surface where surface wave action is not a factor. Except for a thin layer adjacent to the body, this diagram represents the flow in front of and around the sides of the body. The central streamline is seen to branch at the forward tip of the body to form two streamlines along the walls. At the forward tip the velocity must be zero; hence this point is called a **stagnation point**. Other common applications are to flows over spillways, and to seepage flows through earth dams and through the ground under a concrete dam. In the first two of these cases the flow has a **free surface** at

atmospheric pressure. To draw flow nets for free surface flows, one must make use of more advanced principles that are not covered in this text.

Considering the limitations of the flow net in diverging flow, it may be seen that, while the flow net gives a fairly accurate picture of the velocity distribution in the region near the upstream part of any solid body, it may give little information concerning the flow conditions near the rear because of the possibility of separation and eddies. The disturbed flow to the rear of a body is known as a **turbulent wake** (Fig. 4.13b). The space occupied by the wake may be greatly diminished by streamlining the body, i.e., giving the body a long slender tail, which tapers to a sharp edge for two-dimensional flow or to a point for three-dimensional flow.

EXAMPLES OF FLOWNETS

Seepage and Dams

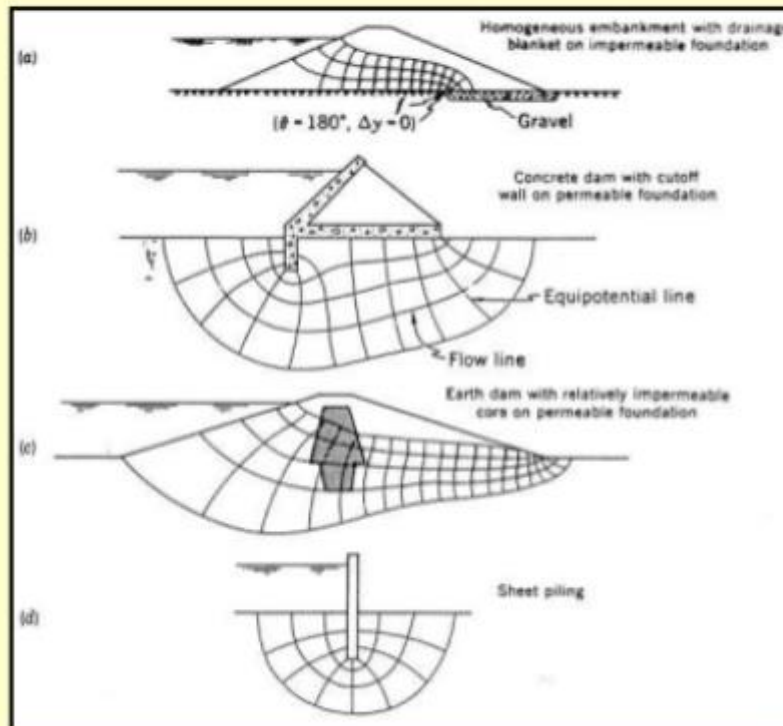

Flow nets for seepage through earthen dams

Seepage under concrete dams

Uses boundary conditions (L & R)

Requires curvilinear square grids for solution

*After Philip Bedient
Rice University*

EXAMPLES OF FLOWNETS

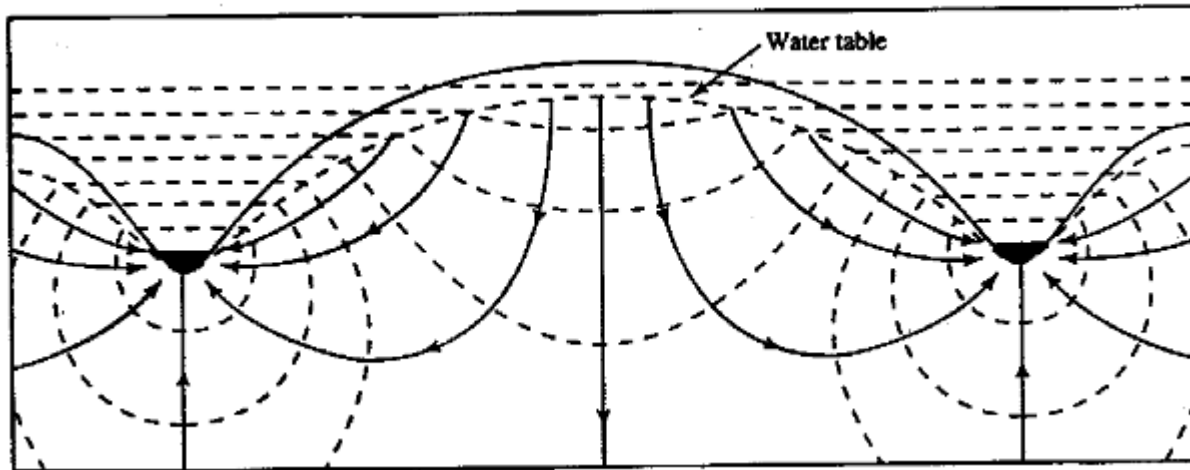

dam and sheet pile cut-off wall

