

Fluid Mechanics CEE 3311

LECTURE 17

Flow in Pipes

(Internal Flows)

L. Handia

Boundary layer: Laminar flow

In the entry region of length L' the flow is *unestablished*; that is, the velocity profile is changing. In this region the flow can be visualized as consisting of a central core in which there are no frictional effects and an outer, annular zone extending from the core to the pipe wall. This outer zone increases in thickness as it moves along the wall, and is known as the *boundary layer*. Viscosity in the boundary layer acts to transmit the effect of boundary shear inwardly into the flow. At section AB the boundary layer has grown until it occupies the entire section of the pipe. At this point, for laminar flow, the velocity profile is a perfect parabola. Beyond section AB , the velocity profile does not change, and the flow is known as *established flow*.

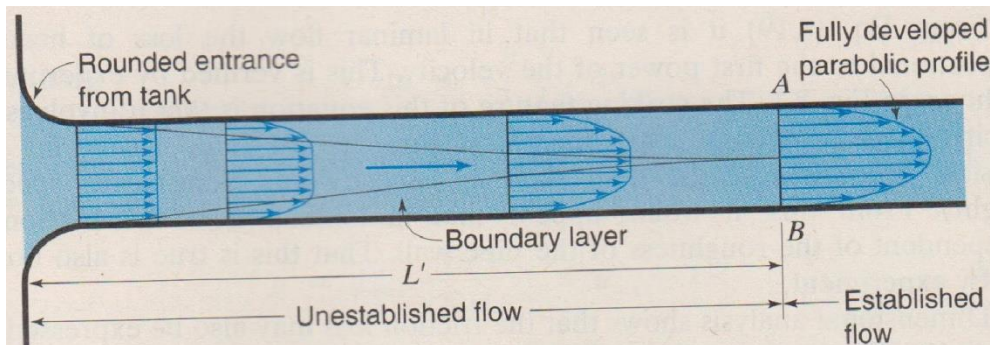

Figure 8.4

Velocity profiles and development of the boundary layer along a pipe in laminar flow.

Boundary layer: Turbulent flow

If the Reynolds number is above the critical value (Sec. 8.2), so that the developed flow is turbulent, the initial condition is much like that in Fig. 8.4. But as the laminar boundary layer increases in thickness, a point is soon reached where a transition occurs and the boundary layer becomes turbulent. This *turbulent boundary layer* generally increases in thickness much more rapidly, and soon the two layers from opposite sides meet at the pipe axis, and there is then *fully developed turbulent flow*.

The **viscous sublayer** is a layer where shear is predominantly due to viscosity alone. It is extremely thin, usually only a few hundredths of a mm, but its effect is great because of the very steep velocity gradient within it and because $\tau = \mu du/dy$ in that region

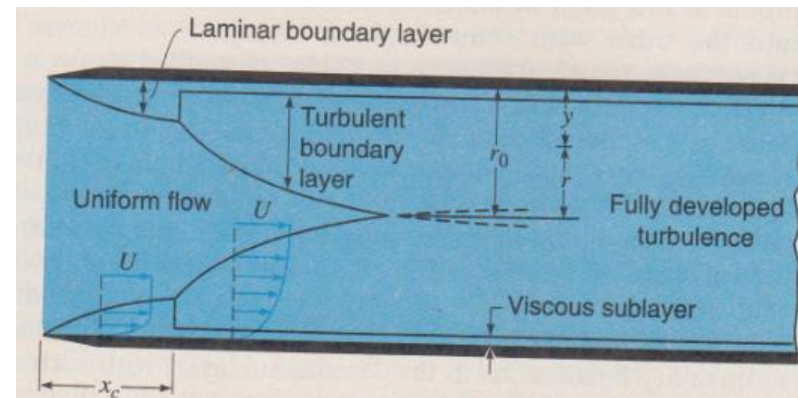
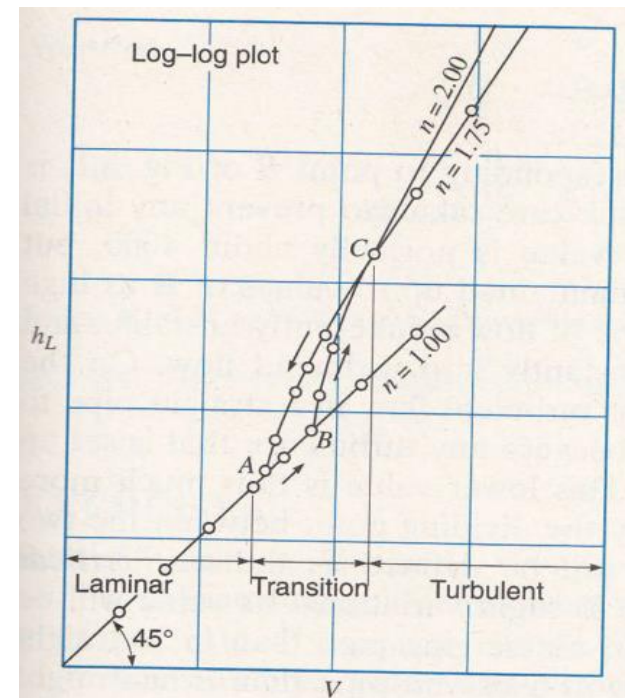

Figure 8.7

Development of boundary layer in a pipe where fully developed flow is turbulent (scales much distorted).

Laminar and turbulent flow

- If the head loss in a given length of uniform pipe is measured at different velocities, it will be found that, as long as the velocity is low enough to secure laminar flow, the *head loss*, due to friction, will be directly *proportional to the velocity*, as shown in the Fig.
- But with increasing velocity, at some point B, where visual observation of dye injected in a transparent tube would show that the flow changes from laminar to turbulent, there will be an *abrupt increase* in the rate at which the head loss varies.



Log-log plot for flow in a uniform pipe ($n = 2.00$, rough-wall pipe; $n = 1.75$, smooth-wall pipe).

Laminar and turbulent flow

- If these two variables are plotted on log-log paper, it will be found that, after a certain transition region (BCA) has been passed, lines will be obtained with slopes ranging from about 1.75 to 2.00.
- It is thus seen that for *laminar flow* the drop in energy due to *friction varies as V* , while for *turbulent flow* the *friction varies as V^n* , where n ranges from about 1.75 to 2. The lower value of 1.75 for turbulent flow is found for pipes with *very smooth walls*; as the wall roughness increases, the value of n increases up to its maximum value of 2.
- Point B is known as the higher critical point, and A as the lower critical point.

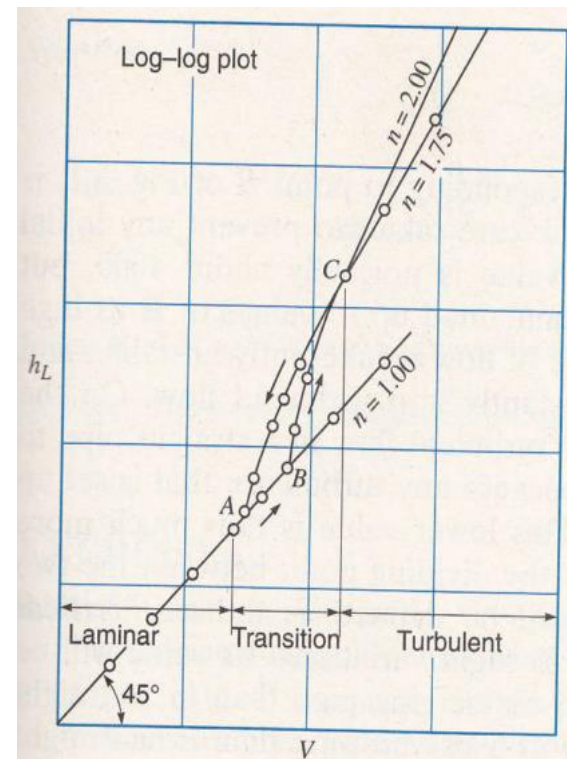

Log-log plot for flow in a uniform pipe ($n = 2.00$, rough-wall pipe; $n = 1.75$, smooth-wall pipe).

Laminar and turbulent flow

- However, velocity is not the only factor that determines whether the flow is laminar or turbulent. The criterion is Reynolds number, which has been discussed in previous lectures.
- For a circular pipe the significant linear dimension L is usually taken as the diameter D , and thus

$$\mathbf{R} = \frac{DV\rho}{\mu} = \frac{DV}{\nu}$$

Laminar and turbulent flow

Critical Reynolds Number

- The upper critical Reynolds number, corresponding to point B of Fig. 17.x is really indeterminate and depends upon the care taken to prevent any initial disturbance from affecting the flow. Its value is normally about 4000 but laminar flow in circular pipes has been maintained up to values of Re as high as 50,000. However, in such cases this type of flow is inherently unstable. 'the least disturbance will transform it instantly into turbulent flow.
- On the other hand, it is practically impossible for turbulent flow in a straight pipe to persist at values of Re much below 2000, because any turbulence that is set will be damped out by viscous friction.
- However, for normal cases of flow in straight pipes of uniform diameter and usual roughness, the critical value may be taken as **$Re_{crit} = 2000$** .

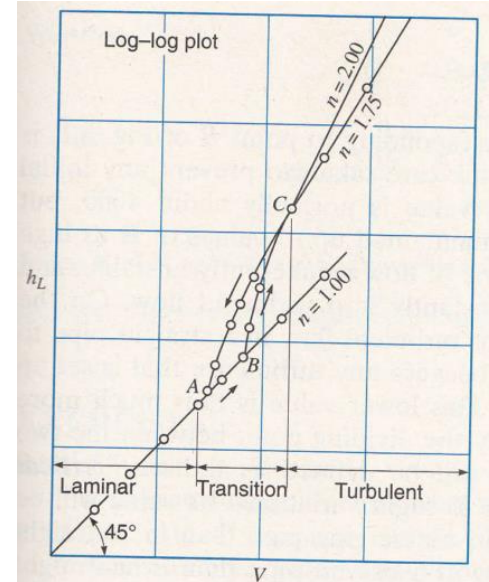

Log-log plot for flow in a uniform pipe ($n = 2.00$, rough-wall pipe; $n = 1.75$, smooth-wall pipe).

Classification between laminar and turbulent flow is defined by the Reynolds number.

$$Re = \frac{VL}{\nu}$$

where V is velocity, L characteristic length and ν is the kinematic viscosity.

The Reynolds number is one of the most important parameters in hydro-mechanics.

Very small Reynolds numbers characterise by definition flows in which the viscous forces dominate and the inertial reactions are negligible.

Very high Reynolds numbers characterise flows in which finally the viscous forces become negligibly small in comparison to the inertial reactions, as for instance in fully turbulent pipe or channel flows.

If the Reynolds number is relatively small, the flow is laminar; if it is large the flow is turbulent.

This is more precisely stated by defining a critical Reynolds number, Re_{crit} , so that the flow is laminar if $Re < Re_{crit}$.

For example, in a flow inside a rough-walled pipe it is found that $Re_{crit} \approx 2000$. This is the minimum critical Reynolds number and is used in most engineering applications.

Laminar and turbulent flow

SAMPLE PROBLEM 8.1 An oil ($s = 0.85$, $\nu = 1.8 \times 10^{-5} \text{ m}^2/\text{s}$) in a refinery flows through a 10-cm-diameter pipe at 0.50 L/s. Is the flow laminar or turbulent?

Solution

$$V = \frac{Q}{A} = \frac{0.0005 \text{ m}^3/\text{s}}{\pi(0.1 \text{ m})^2/4} = 0.0637 \text{ m/s}$$

$$\mathbf{R} = \frac{DV}{\nu} = \frac{0.10 \text{ m}(0.0637 \text{ m/s})}{1.8 \times 10^{-5} \text{ m}^2/\text{s}} = 354$$

Since $\mathbf{R} < \mathbf{R}_{\text{crit}} = 2000$, the flow is laminar. **ANS**

Hydraulic radius

For conduits having *noncircular cross sections*, some value other than the diameter must be used for the linear dimension in the Reynolds number. Such a characteristic is the hydraulic radius, defined as

$$R_h = \frac{A}{P}$$

where A is the cross-sectional area of the flowing fluid, and P is the wetted perimeter, that portion of the perimeter of the cross section where there is contact between fluid and solid boundary.

Laminar flow (Hagen-Poiseuille's formula)

Consider steady flow in a conduit of uniform cross section A , not necessarily circular. The pressures at sections 1 and 2 are P_1 and P_2 , respectively. The distance between them is L . For equilibrium in steady flow, the summation of forces acting on any fluid element must be equal to zero (i.e., $\Sigma F = ma = 0$). Thus in the direction of flow

$$P\Delta A - \left(P + \frac{dP}{ds} \Delta s \right) \Delta A - W \sin \theta - \tau 2\pi r \Delta s = 0$$

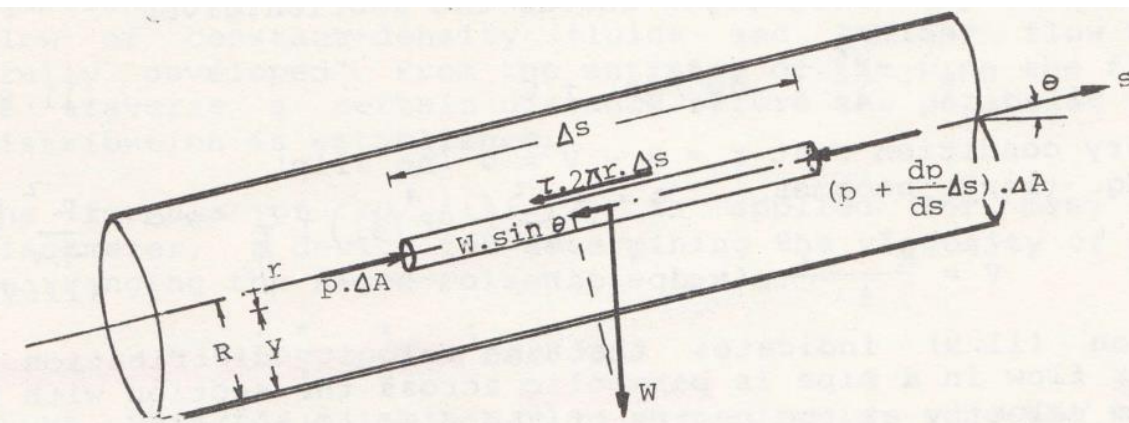
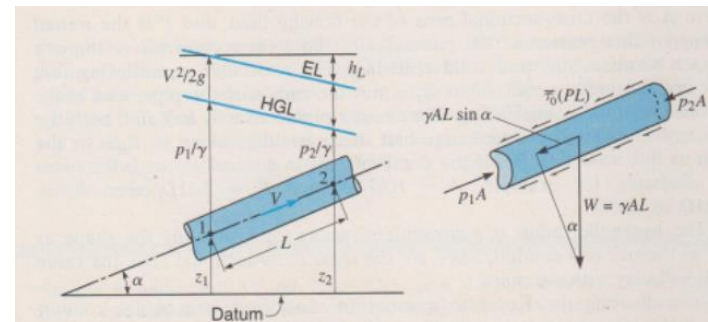

Fig. 11.1 Variation of shear stress in a pipe.



Laminar flow (Hagen-Poiseuille's formula)

$$P\Delta A - \left(P + \frac{dP}{ds} \Delta s \right) \Delta A - W \sin \theta - \tau 2\pi r \Delta s = 0$$

Where $W = \rho g \Delta A \Delta s$ and $\sin \theta = \frac{dz}{ds}$. Therefore equation 11.1 reduces to

$$- \frac{dP}{ds} \Delta s \Delta A - \rho g \Delta A \Delta s \frac{dz}{ds} - \tau 2\pi r \Delta s = 0$$

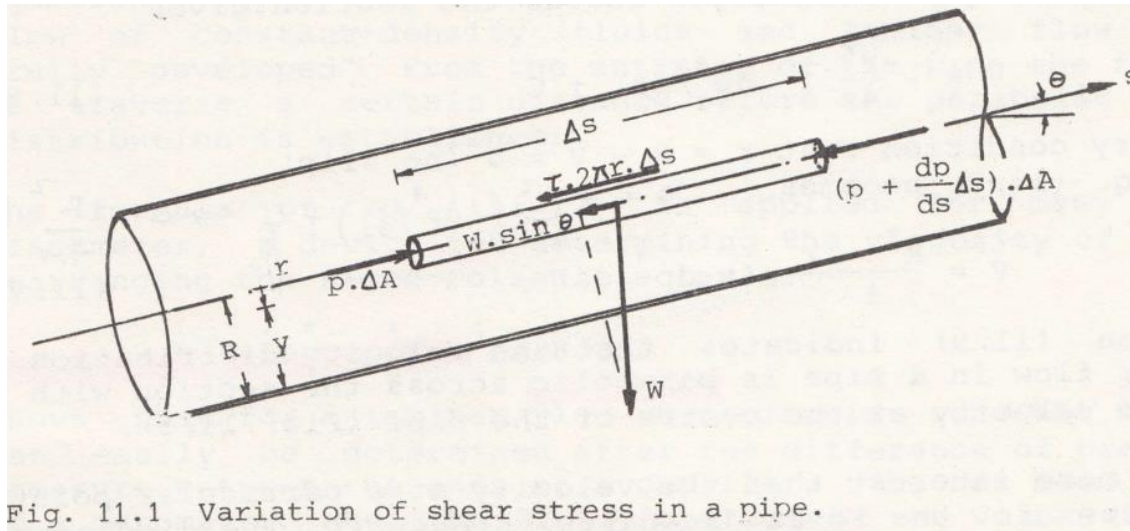

Laminar flow (Hagen-Poiseuille's formula)

$$-\frac{dP}{ds} \Delta s \Delta A - \rho g \Delta A \Delta s \frac{dz}{ds} - \tau 2\pi r \Delta s = 0$$

$\Delta A \Delta s$

$$\frac{\tau 2\pi r}{\pi r^2} = -\frac{d}{ds} (P + \rho g z)$$

$$\tau = \frac{r}{2} \left[-\frac{d}{ds} (P + \rho g z) \right] = \frac{r}{2} \left(-\frac{dP^*}{ds} \right) \quad 11.3$$

where $P^* = P + \rho g z =$ piezometric pressure

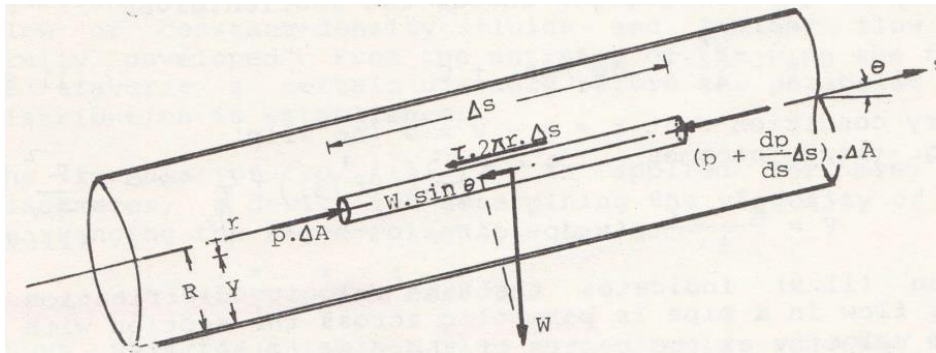

Fig. 11.1 Variation of shear stress in a pipe.

Laminar flow (Hagen-Poiseuille's formula)

Since the gradient itself, dP^*/ds , is negative (piezometric pressure decreases in the direction of flow) and constant across the section for uniform flow, it follows that $-dP^*/ds$ will be positive and constant across the pipe. *At the wall* of the pipe, $r = R$, the shear stress is

$$\tau = \frac{r}{2} \left[-\frac{d}{ds} (P + \rho gz) \right] = \frac{r}{2} \left(-\frac{dP^*}{ds} \right) \quad 11.3$$

$$\tau_0 = \frac{R}{2} \left(-\frac{dP^*}{ds} \right) \quad 11.4$$

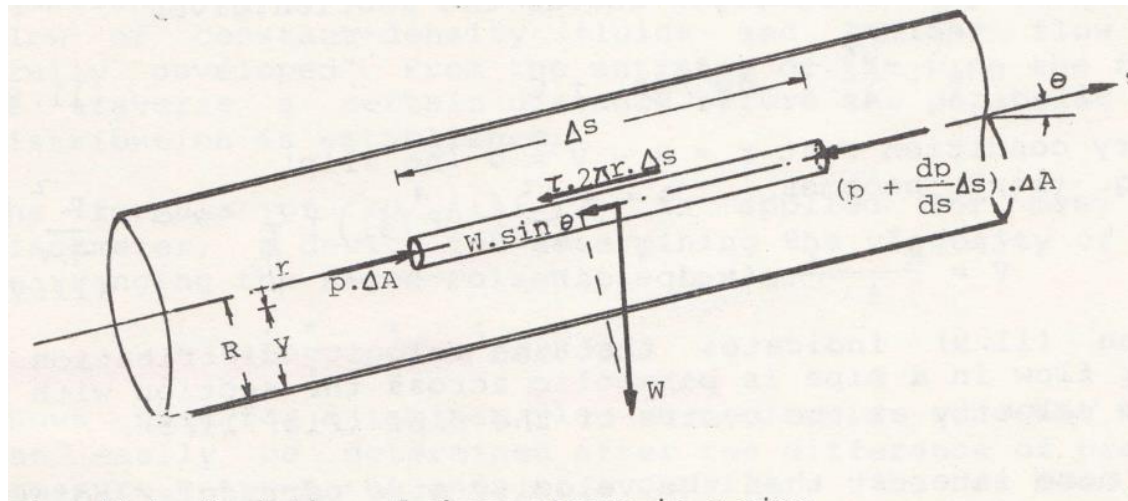

Laminar flow (Hagen-Poiseuille's formula)

Thus, dividing 11.3 by 11.4 gives

$$\frac{\tau = \frac{r}{2} \left(-\frac{dP^*}{ds} \right)}{\tau_0 = \frac{R}{2} \left(-\frac{dP^*}{ds} \right)} \xrightarrow{\tau} \frac{r}{R_0} \tau = \frac{r}{R_0} \tau_0 \xrightarrow{\tau} \quad 11.5$$

Consequently τ varies linearly with r from a value of *zero at the centerline* of the pipe to a *maximum at the wall*. This distribution of stress is represented graphically in Fig 11.2

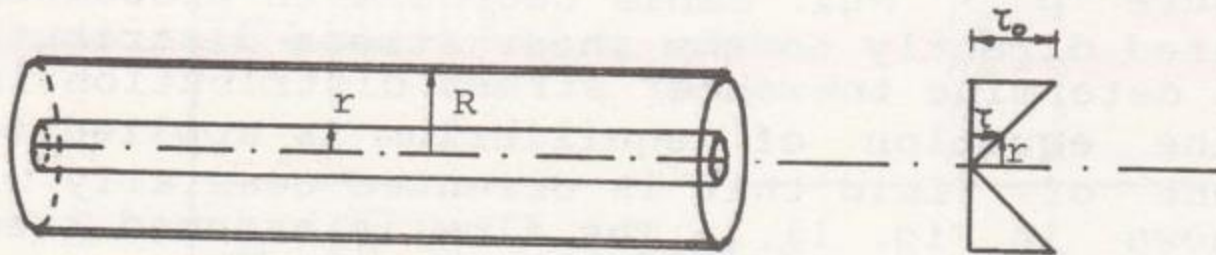

Fig. 11.2. Shear stress distribution in a circular pipe.

Note: in the derivation of 11.5 no restrictions concerning laminar or turbulent flow have been made. Therefore, the law of linear distribution of shear stress over a circular section, represented by 11.5, holds for both flow conditions

Steady laminar flow in circular pipes

From Newton's law of viscosity $\tau = \mu \frac{dV}{dy}$. Substituting this into 11.3 gives

$$\mu \frac{dV}{dy} = \frac{r}{2} \left(-\frac{dP^*}{ds} \right) \quad 11.6$$

$$\tau = \frac{r}{2} \left(-\frac{dP^*}{ds} \right)$$

Noting that $\frac{dV}{dy} = -\frac{dV}{dr}$ (since velocity decreases in the direction of r Fig 11.3), 11.6 becomes

$$\frac{dV}{dr} = -\frac{r}{2\mu} \left(-\frac{dP^*}{ds} \right) \quad 11.7$$

Separating variables and assuming a Newtonian fluid ($\mu =$ constant), then integrating across the section

$$\int dV = -\frac{1}{2\mu} \left(-\frac{dP^*}{ds} \right) \int r dr$$

$$V = -\frac{r^2}{4\mu} \left(-\frac{dP^*}{ds} \right) + C \quad 11.8$$

Steady laminar flow in circular pipes

$$V = -\frac{r^2}{4\mu} \left(-\frac{dP^*}{ds} \right) + C \quad 11.8$$

Boundary condition: at $r = R \rightarrow V = 0$ (no slip)

$$0 = -\frac{R^2}{4\mu} \left(-\frac{dP^*}{ds} \right) + C \Rightarrow C = \frac{R^2}{4\mu} \left(-\frac{dP^*}{ds} \right)$$

$$V = \frac{R^2 - r^2}{4\mu} \left(-\frac{dP^*}{ds} \right) \quad 11.9$$

11.9 indicates that the velocity distribution for *laminar flow* in a pipe is *parabolic* across the section with the maximum velocity at the centre of the pipe Fig 11.3

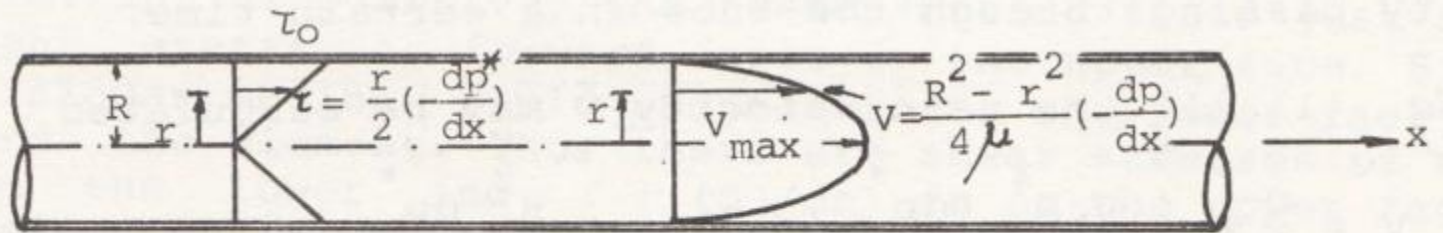
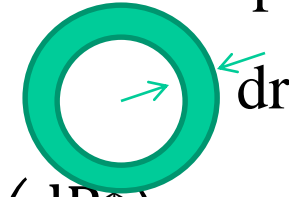

Fig. 11.3 Shear stress and velocity distribution for laminar flow in a pipe.

Steady laminar flow in circular pipes

Of far more interest than the velocity at a particular point is the total discharge through it. The discharge dQ through the annular space between radii r and $r + dr$ is



$$dQ = v 2\pi r dr = \frac{R^2 - r^2}{4\mu} \left(-\frac{dP^*}{ds} \right) 2\pi r dr = -\frac{\pi}{2\mu} \left(\frac{dP^*}{ds} \right) (R^2 r - r^3) dr$$

The discharge through the entire cross section is therefore

$$Q = -\frac{\pi}{2\mu} \left(\frac{dP^*}{ds} \right) \int_0^R (R^2 r - r^3) dr = -\frac{\pi}{2\mu} \left(\frac{dP^*}{ds} \right) \left(R^2 \frac{R^2}{2} - \frac{R^4}{4} \right)$$

Thus $Q = -\frac{\pi R^4}{8\mu} \left(\frac{dP^*}{ds} \right)$ 11.11 **Hagen-Poiseuille Formula**

For a length L of the pipe over which the piezometric pressure drops from P_1 to P_2 , the equation may be written as

$$Q = -\frac{\pi R^4}{8\mu L} (P_1^* - P_2^*) \text{ or more suitable}$$

$$Q = -\frac{\pi D^4}{128\mu L} (P_1^* - P_2^*) \quad 11.12 \text{ where } D \text{ is the diameter}$$

Laminar flow (Hagen-Poiseuille's formula)

Hagen, a German engineer, experimented with water flowing through small brass tubes, and published his results in 1839. Poiseuille, a French scientist, experimented with water flowing through capillary tubes in order to determine the laws of flow of blood through the veins of the body, and published his studies in 1840.

Steady laminar flow in circular pipes

Eq. 11.12 is strictly applicable only to the laminar flow of constant density fluids and laminar flow which is "fully developed". From the entrance of the pipe the fluid has to traverse a certain distance before the parabolic velocity distribution is established.

The formula of Eq.11.12 is applied for many types of viscometer, a device for determining the viscosity of a fluid.

Rearranging the Hagen-Poiseuille law as

$$\mu = \frac{\pi(P_1^* - P_2^*)D^4}{128QL}$$

shows that for a laminar flow in a circular tube, the viscosity can easily be determined after the difference of piezometric pressure between the ends of a capillary tube has been measured by a manometer. When the fluid is a liquid, the volume flow rate Q may be determined simply by collecting and measuring the quantity passing through the tube in a certain time.

Steady laminar flow in circular pipes

From 11.11 the mean velocity \bar{v} may be calculated

$$Q = -\frac{\pi R^4}{8\mu} \left(\frac{dP^*}{ds} \right)$$

$$\bar{v} = \frac{Q}{A} = \frac{-\frac{\pi R^4}{8\mu} \left(\frac{dP^*}{ds} \right)}{\pi R^2} = -\frac{R^2}{8\mu} \left(\frac{dP^*}{ds} \right) \quad 11.13$$

From 11.9 $v = \frac{R^2 - r^2}{4\mu} \left(-\frac{dP^*}{ds} \right)$ it can be seen that the maximum velocity v_{\max} occurs in the centre of the pipe, where $r = 0$. Thus

$$v_{\max} = -\frac{dP^*}{ds} \frac{R^2}{4\mu} \quad 11.14$$

Hence, from 11.13 and 11.14 it may be concluded that $v = v_{\max} / 2$.

For a length L of the pipe, it follows from 11.13 that

$$\bar{v} = \frac{R^2}{8\mu L} (P_1^* - P_2^*) \rightarrow P_1^* = P_2^* + \frac{8\mu L \bar{v}}{R^2} \quad 11.15$$

In terms of “heads” (with $P^* = P + \rho g z$)

$$\frac{p_1}{\rho g} + z_1 = \frac{p_2}{\rho g} + z_2 + \frac{8\mu L \bar{v}}{\rho g R^2} = \frac{p_2}{\rho g} + z_2 + h_f \quad 11.16$$

Where $h_f = \frac{8\mu L \bar{v}}{\rho g R^2}$ = head loss due to frictional resistance of the pipe.

EXAMPLE 7.1

A small-diameter horizontal tube is connected to a supply reservoir as shown in Fig. E7.1. If 6600 mm^3 is captured at the outlet in 10 s, calculate the viscosity of the water.

⁴This equation will be shown to be valid for both laminar and turbulent flows.

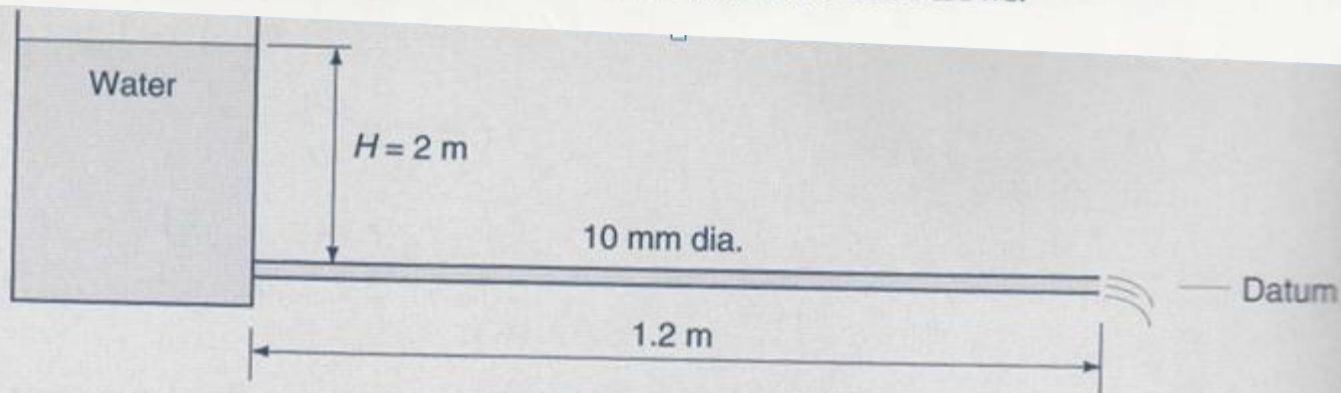

Figure E7.1

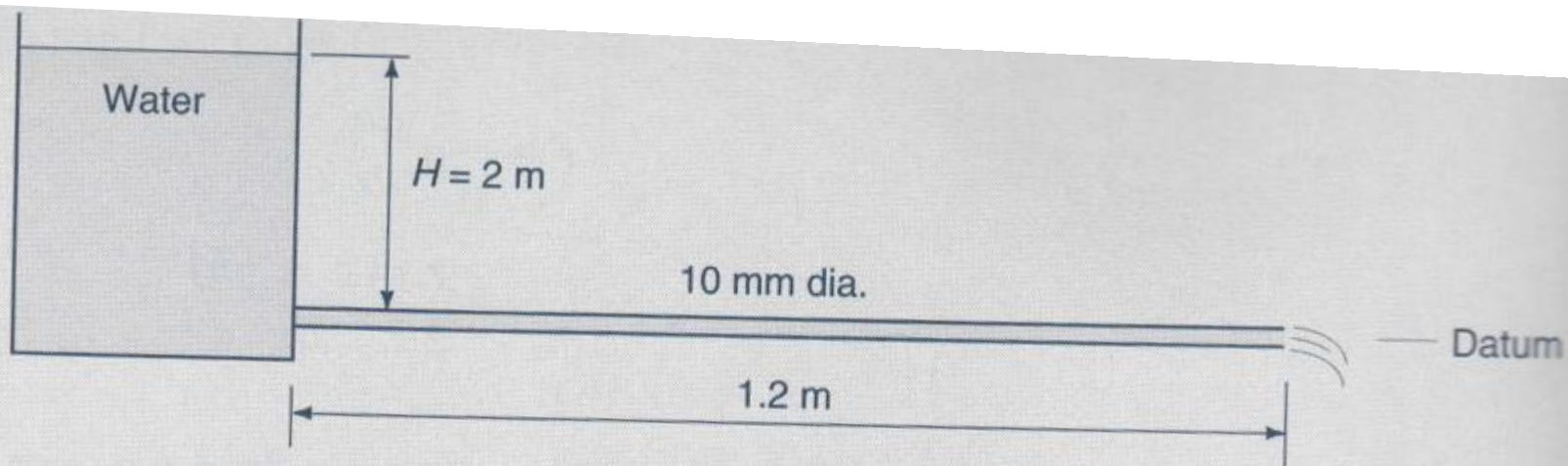

Figure E7.1

Solution: The tube is very small, so we expect viscous effects to limit the velocity to a **small** value. Using Bernoulli's equation from the surface to the entrance to the tube, and neglecting the velocity head, we have, letting 0 be a point on the surface,

$$\frac{p_0}{\gamma} + H = \frac{V^2}{2g} + \frac{p}{\gamma}$$

⁰
negligible

where we have used gage pressure with $p_0 = 0$. This becomes, assuming $V^2/2g \cong 0$,

$$\begin{aligned}
 p &= \gamma H \\
 &= 9800 \times 2 = 19\,600 \text{ Pa}
 \end{aligned}$$

The average velocity is found to be

$$V = \frac{Q}{A}$$
$$= \frac{6600 \times 10^{-9}/10}{\pi \times 0.001^2/4} = 0.840 \text{ m/s}$$

This is quite small ($V^2/2g = 0.036 \text{ m}$ compared with $p/\gamma = 2 \text{ m}$), so the assumption of negligible velocity head is valid. Our pressure calculation is acceptable. Using Eq. 7.3.14, we can find the viscosity to be

$$\mu = \frac{r_0^2 \Delta p}{8V L}$$

$$= \frac{0.0005^2}{8 \times 0.84} (16\,300) = 6.06 \times 10^{-4} \text{ N} \cdot \text{s/m}^2$$

We should check the Reynolds number to determine if our assumption of a laminar flow was acceptable. It is

From Eq. (11.11) the mean velocity \bar{v} may be calculated

$$\bar{v} = \frac{Q}{A} = - \frac{\pi R^4}{8\mu} \cdot \left(\frac{dp^*}{ds} \right) / \pi R^2 = - \frac{R^2}{8\mu} \frac{dp^*}{ds} \quad (11.13)$$

$$\begin{aligned} \text{Re} &= \frac{\rho V D}{\mu} \\ &= \frac{1000 \times 0.84 \times 0.001}{6.06 \times 10^{-4}} = 1390 \end{aligned}$$

This is obviously a laminar flow since $\text{Re} < 2000$, so the calculations are valid providing the entrance length is not too long. It is

$$\begin{aligned} L_E &= 0.065 \text{ Re} \times D \\ &= 0.065 \times 1390 \times 0.001 = 0.09 \text{ m} \end{aligned}$$

This is approximately 8% of the total length, a sufficiently small quantity; hence the calculations are assumed reliable.

Turbulent flow (Darcy-Weisbach formula)

Velocity profile in turbulent flow

In Fig. 8.10 may be seen profiles for both a smooth and a rough pipe. Comparing the turbulent-flow velocity profiles with the laminar-flow velocity profile (Fig. 8.10) shows the turbulent-flow profiles to be much flatter near the central portion of the pipe and steeper near the wall. It is also noticeable that the turbulent profile for the smooth pipe is flatter near the central section (i.e., blunter) than for the rough pipe. In contrast, the velocity profile in laminar flow is independent of pipe roughness.

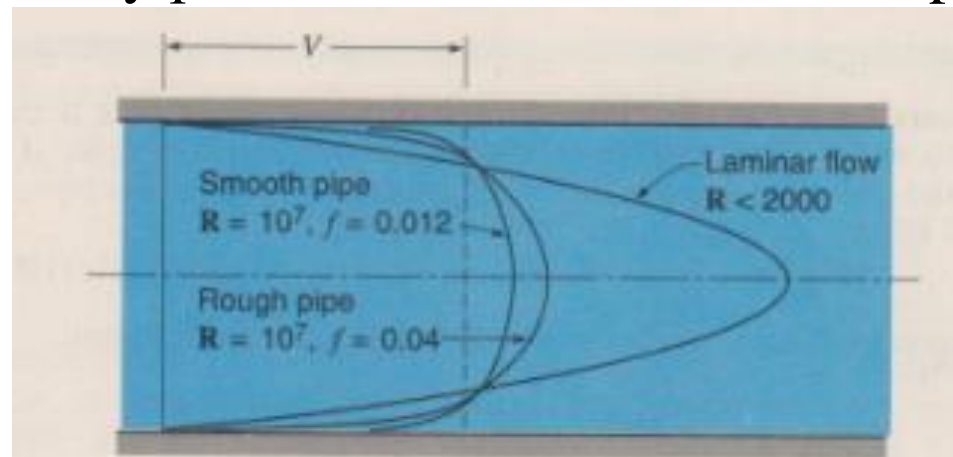

Figure 8.10

Velocity profiles for equal flow rates. The turbulent profiles are plotted from Eq. (8.33).

Turbulent flow (Darcy-Weisbach formula)

In the previous lecture 16, the shear force on a flat plate, friction drag, was expressed as

$$F_f = C_f \rho \frac{V^2}{2} BL$$

The shear stress on a flat plate is then $\tau_0 = \frac{F_f}{A} = C_f \rho \frac{v_0^2}{2}$

For pipe flow it is customary to express τ_0 in a similar manner; however, we use the *mean velocity* as the reference velocity, and the coefficient of proportionality is given as $f/4$ instead of C_f . Here f is called the resistance coefficient, or more usual, the *friction factor* of the pipe.

Turbulent flow (Darcy-Weisbach formula)

Thus we have

$$\tau_0 = \frac{f}{4} \rho \frac{v^2}{2} \quad 12.5$$

In section on Laminar Flow it was found that the shear stress at the wall of the pipe

$$\tau_0 = \frac{R}{2} \left(-\frac{dP^*}{ds} \right) \quad 11.4$$

Equating 12.5 and 11.4

$$\frac{f}{4} \rho \frac{v^2}{2} = \frac{R}{2} \left(-\frac{dP^*}{ds} \right) \Rightarrow \frac{\frac{f}{4} \rho \frac{v^2}{2}}{\rho g} = \frac{R}{2} \left(-\frac{dP^*}{ds} \right) \frac{1}{\rho g}$$

$$-dP^* = \frac{f}{4} \frac{v^2}{2g} \frac{2\rho g ds}{R} \Rightarrow \frac{-dP^*}{\rho g} = \frac{f}{4} \frac{v^2}{2g} \frac{2ds}{R} \Rightarrow \frac{-dP^*}{\rho g} = \frac{f}{4} \frac{ds}{D} \frac{v^2}{2g}$$

$$\frac{-1}{\rho g} \int_{P_1^*}^{P_2^*} dP^* = \frac{f}{4} \frac{1}{D} \frac{v^2}{2g} \int_{s_1}^{s_2} ds \Rightarrow \frac{P_1^*}{\rho g} - \frac{P_2^*}{\rho g} = f \frac{L}{D} \frac{v^2}{2g}$$

Turbulent flow (Darcy-Weisbach formula)

$$\frac{P_1^*}{\rho g} - \frac{P_2^*}{\rho g} = f \frac{L}{D} \frac{v^2}{2g} \Rightarrow h_1 - h_2 = f \frac{L}{D} \frac{v^2}{2g}$$

$$h_1 - h_2 = h_L = f \frac{L}{D} \frac{v^2}{2g} \quad 12.6 \quad \text{Darcy Weisbach Equation}$$

where h_L = head loss created by viscous effects and is equal to the change of piezometric head.

Although the Darcy Weisbach Equation is for turbulent flow, it can still be used for laminar flow. For laminar flow, where $h_f = \frac{8\mu L \bar{v}}{\rho g R^2}$: (Eq.11.16), it can easily be shown that

$$f = 64/\text{Re} \quad 12.7$$

Hence, if Re is less than 2,000 (laminar flow), one may use Eq. 12.6 with the value of f as given by Eq. 12.7

Chart (and equations) for friction factor

The friction factor f depends on the various quantities that affect the flow, written as

$$f = f(\rho, \mu, V, D, e) \quad (7.6.24)$$

where the average wall roughness height e accounts for the influence of the wall roughness elements. A dimensional analysis, not covered in this course, provides us with

$$f = f\left(\frac{\rho v D}{\mu}, \frac{e}{D}\right)$$

where e/D is the relative roughness.

Experimental data that relate the friction factor to the Reynolds number have been obtained for fully developed pipe flow over a wide range of wall roughnesses. The results of these data are presented in Fig. 7.13, which is commonly referred to as the **Moody diagram**.

Figure 8.11
Moody chart for pipe friction factor (Stanton diagram).

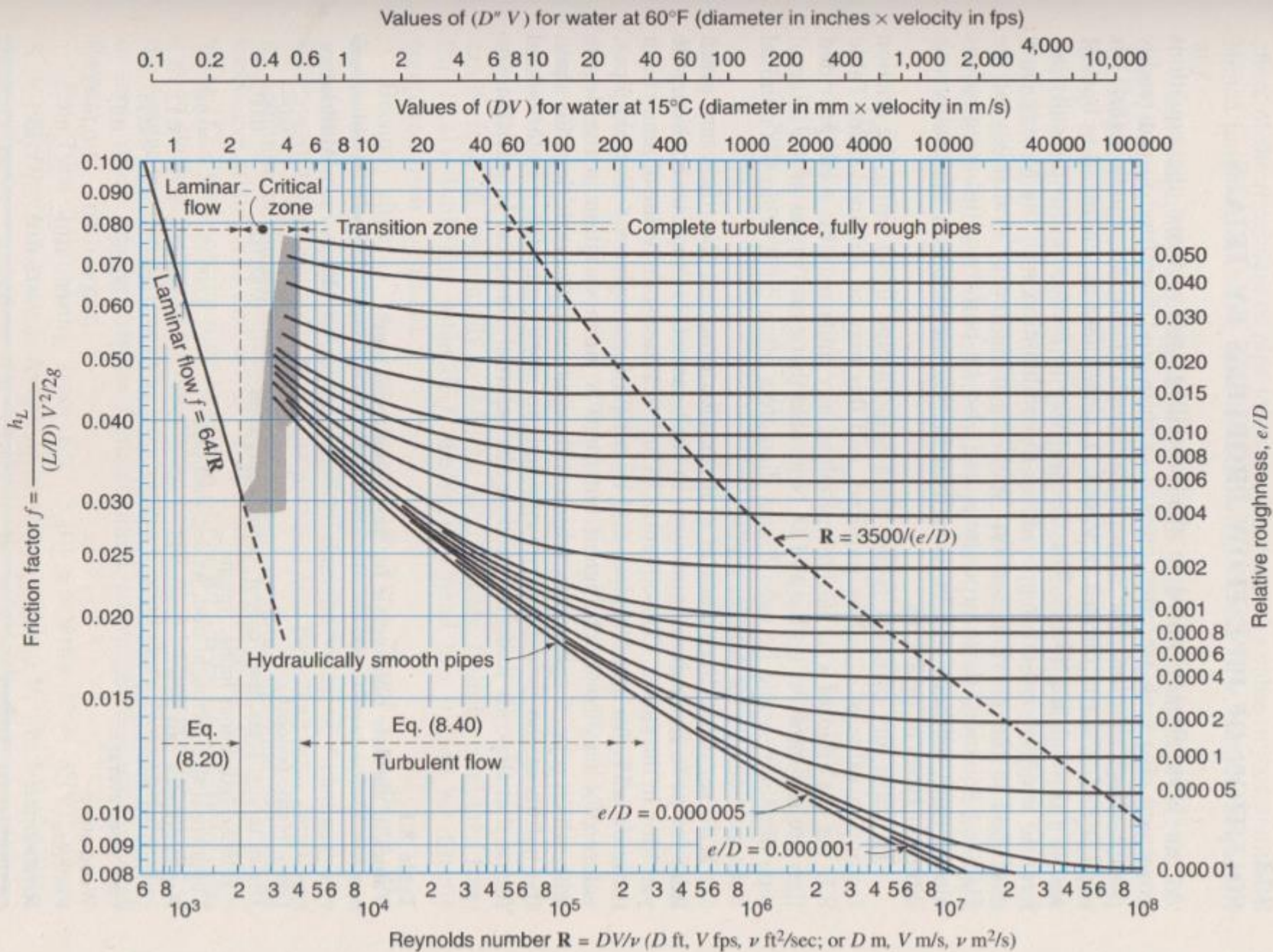

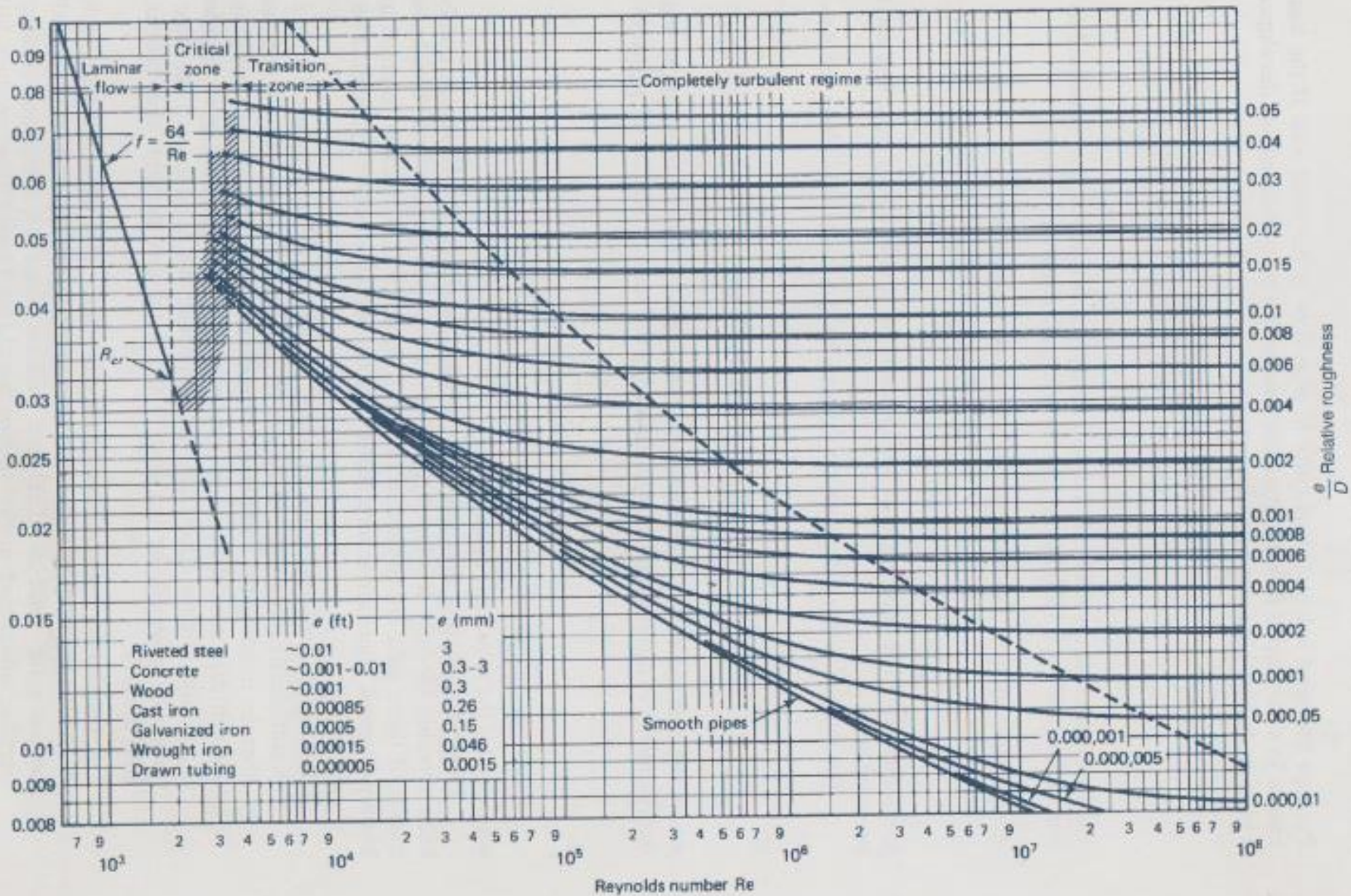

Figure 7.13 Moody diagram. (From L. F. Moody, *Trans. ASME*, Vol. 66, 1944.)

There are several features of the Moody diagram that should be noted.

- For a given wall roughness, measured by the relative roughness e/D , there is a sufficiently large value of Re above which the *friction factor is constant*, thereby *defining the completely turbulent regime*. The average roughness element size e is substantially greater than the viscous wall layer thickness δ_v , so that viscous effects are not significant; the resistance to the flow is produced primarily by the drag of the roughness elements that protrude into the flow.
- For the smaller relative roughness e/D values it is observed that, as Re decreases, the friction factor increases in the transition zone and eventually becomes the same as that of a smooth pipe. The roughness elements become submerged in the viscous wall layer so that they produce little effect on the main flow.
- For Reynolds numbers less than 2000, the friction factor of laminar flow is shown. The critical zone couples the turbulent flow to the laminar flow and may represent an oscillating flow that alternately exists between turbulent and laminar flow.
- The e values in this diagram are for new pipes. *With age a pipe will corrode and become fouled, changing both the roughness and the pipe diameter, with a resulting increase in the friction factor*. Such factors should be included in design considerations; they will not be reviewed here.

The following **empirical** equations represent the Moody diagram for $Re > 4000$:

Smooth pipe flow:
$$\frac{1}{\sqrt{f}} = 0.86 \ln Re \sqrt{f} - 0.8 \quad (7.6.26)$$

Completely turbulent zone:
$$\frac{1}{\sqrt{f}} = -0.86 \ln \frac{e}{3.7D} \quad (7.6.27)$$

Transition zone:
$$\frac{1}{\sqrt{f}} = -0.86 \ln \left(\frac{e}{3.7D} + \frac{2.51}{Re\sqrt{f}} \right) \quad (7.6.28)$$

Good approximations can be made for the head loss in conduits with **noncircular cross sections** by using the hydraulic radius R .

The transition zone equation (7.6.28) that couples the smooth pipe equation to the completely turbulent regime equation is known as the Colebrook equation. Note that Eq. 7.6.26 is the ***Colebrook equation*** with $e = 0$, and Eq. 7.6.27 is the Colebrook equation with $Re = \infty$.

Solution of pipe flow problems by trials

Three categories of problems can be identified for developed turbulent flow in a pipe length L :

<i>Category</i>	<i>Known</i>	<i>Unknown</i>
1	Q, D, e, ν	h_L
2	D, e, ν, h_L	Q
3	Q, e, ν, h_L	D

A category 1 problem is straightforward and requires no iteration procedure when using the Moody diagram.

Category 2 and 3 problems are more like problems encountered in engineering design situations and require an iterative trial-and-error process when using the Moody diagram.

An alternative to using the Moody diagram that avoids any trial-and-error process is made possible by empirically derived formulas.

Perhaps the best of such formulas were presented by Swamee and Jain (1976) for pipe flow; an explicit expression that provides an approximate value for the unknown in each category above is as follows:

Solution of pipe flow problems using empirical equations

➤ An alternative to using the Moody diagram that avoids any trial-and-error process is made possible by empirically derived formulas.

➤ Perhaps the best of such formulas were presented by Swamee and Jain (1976) for pipe flow; an explicit expression that provides an approximate value for the unknown in each category above is as follows:

Category	Known	Unknown
1	Q, D, e, ν	h_L
2	D, e, ν, h_L	Q
3	Q, e, ν, h_L	D

$$h_L = 1.07 \frac{Q^2 L}{g D^5} \left\{ \ln \left[\frac{e}{3.7 D} + 4.62 \left(\frac{\nu D}{Q} \right)^{0.9} \right] \right\}^{-2} \quad \begin{array}{l} 10^{-6} < e/D < 10^{-2} \\ 3000 < \text{Re} < 3 \times 10^8 \end{array} \quad (7.6.31)$$

$$Q = -0.965 \left(\frac{g D^5 h_L}{L} \right)^{0.5} \ln \left[\frac{e}{3.7 D} + \left(\frac{3.17 \nu^2 L}{g D^3 h_L} \right)^{0.5} \right] \quad \text{Re} > 2000 \quad (7.6.32)$$

$$D = 0.66 \left[e^{1.25} \left(\frac{L Q^2}{g h_L} \right)^{4.75} + \nu Q^{9.4} \left(\frac{L}{g h_L} \right)^{5.2} \right]^{0.04} \quad \begin{array}{l} 10^{-6} < e/D < 10^{-2} \\ 5000 < \text{Re} < 3 \times 10^8 \end{array} \quad (7.6.33)$$

Solution of pipe flow problems using empirical equations

➤ Equation 7.6.32 is as accurate as the Moody diagram, and Eqs. 7.6.31 and 7.6.33 are accurate to within approximately 2% of the Moody diagram. These tolerances are acceptable for engineering calculations. It is important to realize that the Moody diagram is based on experimental data that likely is accurate to within no more than 5%.

➤ Hence the foregoing three formulas of Swamee and Jain, which can easily be input on a programmable hand-held calculator, are often used by design engineers.

$$h_L = 1.07 \frac{Q^2 L}{gD^5} \left\{ \ln \left[\frac{e}{3.7D} + 4.62 \left(\frac{\nu D}{Q} \right)^{0.9} \right] \right\}^{-2} \quad \begin{array}{l} 10^{-6} < e/D < 10^{-2} \\ 3000 < \text{Re} < 3 \times 10^8 \end{array} \quad (7.6.31)$$

$$Q = -0.965 \left(\frac{gD^5 h_L}{L} \right)^{0.5} \ln \left[\frac{e}{3.7D} + \left(\frac{3.17 \nu^2 L}{gD^3 h_L} \right)^{0.5} \right] \quad \text{Re} > 2000 \quad (7.6.32)$$

$$D = 0.66 \left[e^{1.25} \left(\frac{LQ^2}{gh_L} \right)^{4.75} + \nu Q^{9.4} \left(\frac{L}{gh_L} \right)^{5.2} \right]^{0.04} \quad \begin{array}{l} 10^{-6} < e/D < 10^{-2} \\ 5000 < \text{Re} < 3 \times 10^8 \end{array} \quad (7.6.33)$$

EXAMPLE 7.10

Water at 20°C is transported for 500 m in a 4-cm-diameter wrought iron horizontal pipe with a flow rate of 0.003 m³/s. Calculate the pressure drop over the 500-m length of pipe.

Solution: The average velocity is

$$\begin{aligned} V &= \frac{Q}{A} \\ &= \frac{0.003}{\pi \times 0.02^2} = 2.39 \text{ m/s} \end{aligned}$$

The Reynolds number is

$$\begin{aligned} \text{Re} &= \frac{VD}{\nu} \\ &= \frac{2.39 \times 0.04}{10^{-6}} = 9.6 \times 10^4 \end{aligned}$$

Obtaining e from Fig. 7.13, we have, using $D = 40$ mm,

$$\frac{e}{D} = \frac{0.046}{40} = 0.00115$$

The friction factor is read from the Moody diagram to be

$$f = 0.023$$

The head loss is calculated as

$$\begin{aligned} h_L &= f \frac{L}{D} \frac{V^2}{2g} \\ &= 0.023 \frac{500}{0.04} \frac{2.39^2}{2 \times 9.81} = 84 \text{ m} \end{aligned}$$

This answer is given to two significant numbers since the friction factor is known to at most two significant numbers. The pressure drop is found to be

$$\begin{aligned} \Delta p &= \gamma h_L \\ &= 9800 \times 84 = 820\,000 \text{ Pa} \quad \text{or} \quad 820 \text{ kPa} \end{aligned}$$

Using Eq. 7.6.31 we find

$$\begin{aligned} h_L &= 1.07 \frac{0.003^2 \times 500}{9.81 \times (0.04)^5} \left\{ \ln \left[\frac{0.00115}{3.7} + 4.62 \left(\frac{10^{-6} \times 0.04}{0.003} \right)^{0.9} \right] \right\}^{-2} \\ &= 1.07 \times 4480 \times 0.01731 = 83 \text{ m} \end{aligned}$$

This value is essentially the same as the value using the Moody diagram.

Minor losses in pipe flow

We now know how to calculate the losses due to a developed flow in a pipe. Pipe systems do, however, include valves, elbows, enlargements, contractions, inlets, outlets, bends, and other fittings that cause additional losses, referred to as **minor losses**. Each of these devices causes a change in the magnitude and/or the direction of the velocity vectors and hence results in a loss. In general, if the flow is gradually accelerated by a device, the losses are very small; relatively large losses are associated with sudden enlargements because of the separated regions that result (a separated flow occurs when the primary flow separates from the wall).

A minor loss is expressed in terms of a loss coefficient K , defined by

$$h_L = K \frac{V^2}{2g} \quad (7.6.34)$$

Values of K have been determined experimentally for the various fittings and geometry changes of interest in piping systems. One exception is the sudden expansion from area A_1 to area A_2 , for which the loss can be calculated; this was done in Example 4.14, where we found that

$$h_L = \left(1 - \frac{A_1}{A_2}\right)^2 \frac{V_1^2}{2g} \quad (7.6.35)$$

Minor losses in pipe flow

Thus, for the sudden expansion

$$K = \left(1 - \frac{A_1}{A_2}\right)^2 \quad (7.6.36)$$

If A_2 is extremely large (e.g., a pipe exiting into a reservoir), $K = 1.0$, an obvious result since the entire kinetic energy is lost.

A pipe fitting that has a relatively large loss coefficient with no change in cross-sectional area is the pipe bend, or the elbow. This results primarily from the secondary flow caused by the fluid flowing from the high-pressure region to the low-pressure region, as shown in Fig. 7.14; this secondary flow is eventually dissipated after the fluid leaves the long sweep bend or elbow. In addition, a separated region occurs at the sharp corner in a standard elbow. Energy is needed to maintain such a secondary flow and the flow in the separated region. This wasted energy is measured in terms of a loss coefficient.

The loss coefficients for various geometries are presented in Table 7.2 and Fig. 7.25. A globe valve may be used to control the flow rate by introducing large losses by partially closing the valve. The other types of valves should not be used to control the flow; damage could result.

Minor losses in pipe flow

Loss coefficients for sudden contractions and orifice plates can be approximated by neglecting the losses in the converging flow up to the vena contracta and calculating the losses in the diverging flow using the loss coefficient for a sudden expansion. Figure 7.10 provides the information necessary to establish the area of the **vena contracta**, the minimum area; this minimum area results when the converging streamlines begin to expand to fill the downstream area.

It is often the practice to express a loss coefficient as an **equivalent length** L_e of pipe. This is done by equating Eq. 7.6.34 to Eq. 7.6.23:

$$h_L = K \frac{V^2}{2g}$$

$$K \frac{V^2}{2g} = f \frac{L_e}{D} \frac{V^2}{2g}$$

$$h_L = f \frac{L_e}{D} \frac{V^2}{2g}$$

(7.6.35)

giving the relationship

$$L_e = K \frac{D}{f}$$

(7.6.36)

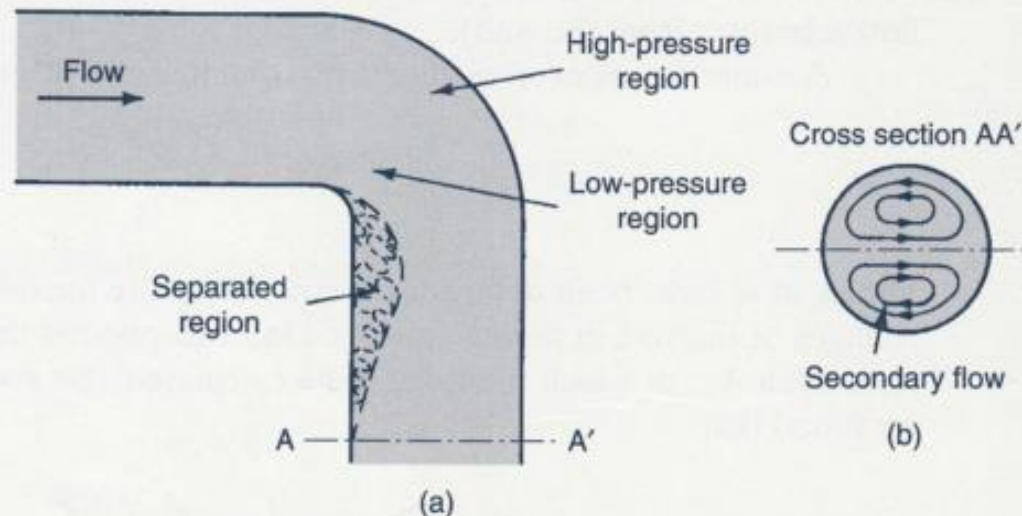











Figure 7.14 Flow in an elbow.

TABLE 7.2 Nominal Loss Coefficients K (Turbulent Flow)*

Type of fitting <i>Diameter</i>	Screwed			Flanged		
	1 in.	2 in.	4 in.	2 in.	4 in.	8 in.
Globe valve (fully open)	8.2	6.9	5.7	8.5	6.0	5.8
(half open)	20	17	14	21	15	14
(one-quarter open)	57	48	40	60	42	41
Angle valve (fully open)	4.7	2.0	1.0	2.4	2.0	2.0
Swing check valve (fully open)	2.9	2.1	2.0	2.0	2.0	2.0
Gate valve (fully open)	0.24	0.16	0.11	0.35	0.16	0.07
Return bend	1.5	.95	.64	0.35	0.30	0.25
Tee (branch)	1.8	1.4	1.1	0.80	0.64	0.58
Tee (line)	0.9	0.9	0.9	0.19	0.14	0.10
Standard elbow	1.5	0.95	0.64	0.39	0.30	0.26
Long sweep elbow	0.72	0.41	0.23	0.30	0.19	0.15
45° elbow	0.32	0.30	0.29			
Square-edged entrance 			0.5			
Reentrant entrance 			0.8			
Well-rounded entrance 			0.03			
Pipe exit			1.0			
	<u>Area ratio</u>					
Sudden contraction ^b 	2:1		0.25			
	5:1		0.41			
	10:1		0.46			
	<u>Area ratio A/A_0</u>					
Orifice plate 	1.5:1		0.85			
	2:1		3.4			
	4:1		29			
	$\geq 6:1$		$2.78 \left(\frac{A}{A_0} - 0.6 \right)^2$			
Sudden enlargement ^c 			$\left(1 - \frac{A_1}{A_2} \right)^2$			
90° miter bend (without vanes) 			1.1			
(with vanes) 			0.2			
General contraction 	(30° included angle)		0.02			
	(70° included angle)		0.07			

*Values for other geometries can be found in *Technical Paper 410*, The Crane Company, 1957.

^bBased on exit velocity V_2 .

^cBased on entrance velocity V_1 .

EXAMPLE 7.14

If the flow rate through a 10-cm-diameter wrought iron pipe (Fig. E7.14) is $0.04 \text{ m}^3/\text{s}$, find the difference in elevation H of the two reservoirs.

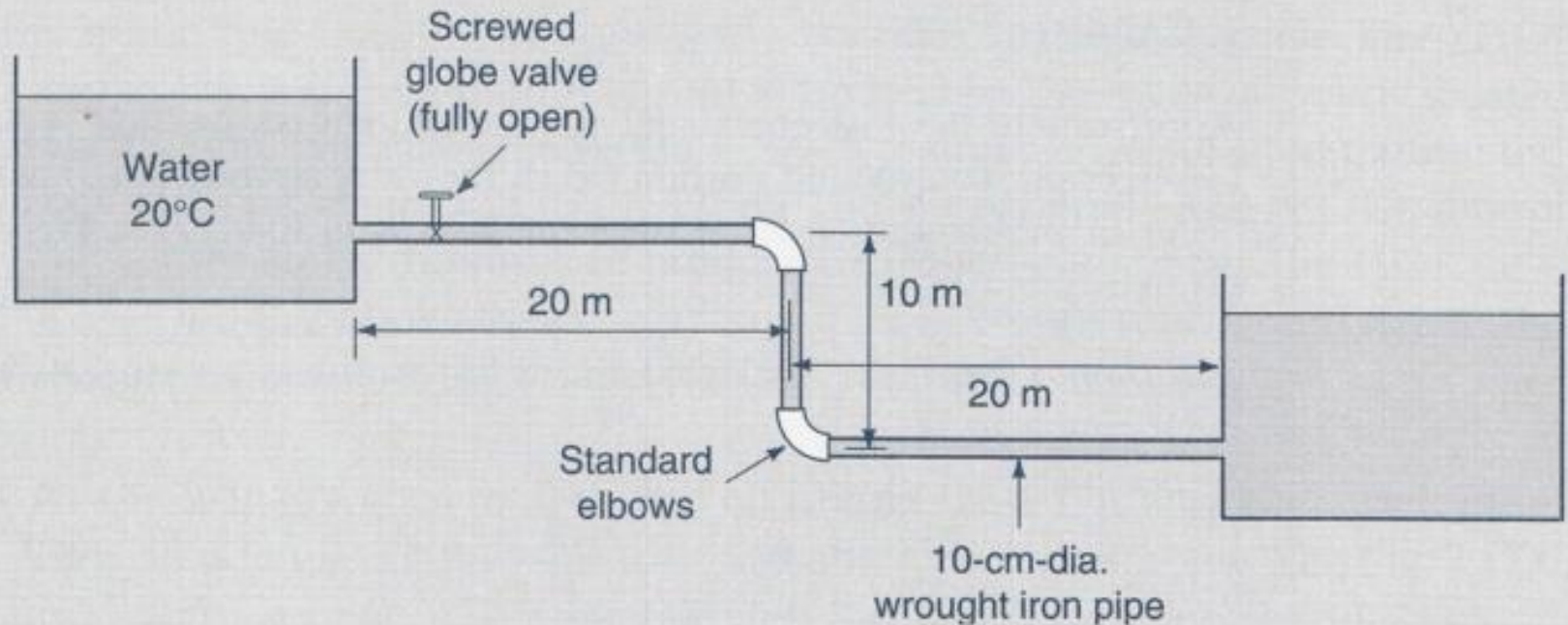

Figure E7.14

Solution: The energy equation written for a control volume that contains the two reservoir surfaces (see Eq. 4.4.17), where $V_1 = V_2 = 0$ and $p_1 = p_2 = 0$, is

$$\alpha_1 \frac{v_1^2}{2g} + \frac{p_1}{\rho g} + z_1 + h_p = \alpha_2 \frac{v_2^2}{2g} + \frac{p_2}{\rho g} + z_2 + h_t + h_l$$

$$0 = z_2 - z_1 + h_L$$

Thus, letting $z_1 - z_2 = H$, we have

$$H = (K_{\text{entrance}} + K_{\text{valve}} + 2K_{\text{elbow}} + K_{\text{exit}}) \frac{V^2}{2g} + f \frac{L}{D} \frac{V^2}{2g}$$

The average velocity, Reynolds number, and relative roughness are

$$V = \frac{0.04}{\pi \times 0.05^2} = 5.09 \text{ m/s}$$

$$\text{Re} = \frac{5.09 \times 0.1}{10^{-6}} = 5.09 \times 10^5$$

$$\frac{e}{D} = \frac{0.046}{100} = 0.00046$$

From the Moody diagram we find that

From the Moody diagram we find that

$$f = 0.0173$$

Using the loss coefficients from Table 7.2 for screwed 4-in. (10 cm = 3.94 in.) elements there results

$$\begin{aligned} H &= (0.5 + 5.7 + 2 \times 0.64 + 1.0) \frac{5.09^2}{2 \times 9.8} + 0.0173 \frac{50}{0.1} \frac{5.09^2}{2 \times 9.8} \\ &= 11.2 + 11.4 = 22.6 \text{ m} \end{aligned}$$