



THE UNIVERSITY OF ZAMBIA

SCHOOL OF ENGINEERING

DEPARTMENT OF CIVIL AND ENVIRONMENTAL ENGINEERING

Name: Chinyemba Richard

Computer Number: 2019027828

Course Code: CEE 3311

Course Name: Fluid Mechanics

Year: 3rd

Lab Number: 01

For the Attention of: Dr. L. Handia

Tutor: Eng. Kakoma Peter

Due Date: 21/12/2021

INTRODUCTION

Water turbines are widely used throughout the world to generate power. In the type of water turbine referred to as a Pelton wheel, one or more water jets are directed tangentially on to vanes or buckets that are fastened to the rim of the turbine disc. The impact of the water on the vanes generates a torque on the wheel, causing it to rotate and to develop power. It may be noted that the Pelton wheel is best suited to conditions where the available head of water is great, and the flow rate is comparatively small. For example, with a head of 100 m and a flow rate of $1 \text{ m}^3/\text{s}$, a Pelton wheel running at some 250 rev/min could be used to develop about 900 kW. The same water power would be available if the head were only 10 m and the flow were $10 \text{ m}^3/\text{s}$, but a different type of turbine would then be needed.

To predict the output of a Pelton wheel, and to determine its optimum rotational speed, we need to understand how the deflection of the jet generates a force on the buckets, and how the force is related to the rate of momentum flow in the jet. In this

experiment, we measure the force generated by a jet of water striking a flat plate or a hemispherical cup, and compare the results with the computed momentum flow rate in the jet.

DESCRIPTION OF APARATUS

The figure below shows the arrangement, in which water supplied from the Hydraulic Bench is fed to a vertical pipe terminating in a tapered nozzle. This produces a jet of water which impinges on a vane, in the form of a flat plate or a hemispherical cup. The nozzle and vane are contained within a transparent cylinder, and at the base of the cylinder there is an outlet from which the flow is directed to the measuring tank of the bench.

The vane is supported by a lever which carries a jockey weight, and which is restrained by a light spring. The lever may be set to a balanced position (as indicated by a tally supported from it) by placing the jockey weight at its zero position, and then adjusting the knurled nut above the spring. Any force generated by impact of the jet on the vane may now be measured by moving the jockey weight along the lever until the tally shows that it has been restored to its original balanced position.

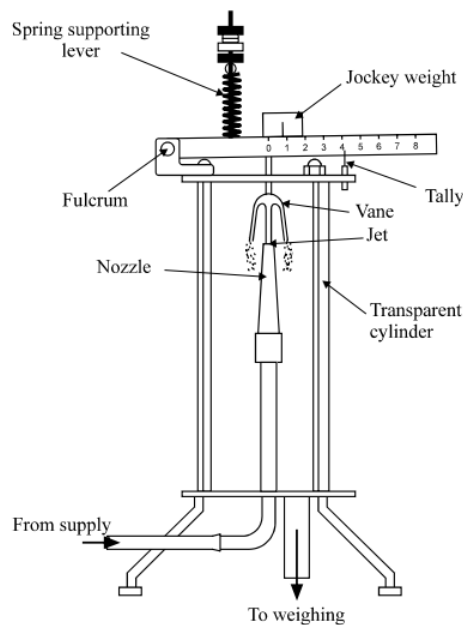

OBJECTIVES:

This experiment aims to:

1. Observe the force exerted on a surface (vane) by a fluid jet.
2. Calculate the force produced by a jet of water, when it strikes a flat vane or a hemispherical cup.

- Compare the results measured with the theoretical values calculated from the momentum flux in the jet

THEORY OF THE EXPERIMENT

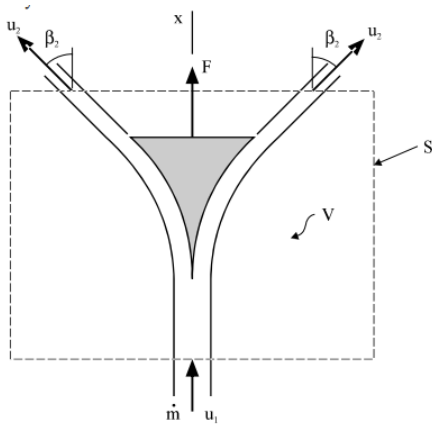

Let the mass flow rate in the jet be m .

Imagine a control volume V , bounded by a control surface S which encloses the vane as shown. The velocity with which the jet enters the control volume is u_1 , in the x -direction. The jet is deflected by its impingement on the vane, so that it leaves the control volume with velocity u_2 , inclined at an angle β_2 to the x -direction. Now the pressure over the whole surface of the jet, apart from that part where it flows over the surface of the vane, is atmospheric. Therefore, neglecting the effect of gravity, the changed direction of the jet is due solely the force generated by pressure and shear stress at the vane's surface. If this force on the jet in the direction of x be denoted by F_J , then the momentum equation in the x -direction is

$$F_J = m (u_2 \cos \beta_2 - u_1) \text{ eqn i}$$

The force F on the vane is equal and opposite to this, namely

$$F = m (u_1 - u_2 \cos \beta_2) \text{ eqn ii}$$

For the case of a flat plate, $\beta_2 = 90^\circ$, so that $\cos \beta_2 = 0$.

It follows that $F = m u_1$ (eqn iii) is the force on the flat plate, irrespective of the value of u_2 .

For the case of a hemispherical cup, we assume that $\beta_2 = 180^\circ$, so that $\cos \beta_2 = -1$, and $F = m (u_1 + u_2)$ eqn iv

If we neglect the effect of change of elevation on jet speed, and the loss of speed due to friction over the surface of the vane, then $u_1 = u_2$,

Hence, $F = 2mu_1$ is the maximum possible value of force on the hemispherical cup. This is just twice the force on the flat plate.

EXPERIMENTAL PROCEDURE

1. The apparatus is first levelled and the lever brought to the balanced position (as indicated by the tally), with the jockey weight at its zero setting.
2. Note the weight of the jockey, and the following dimensions: diameter of the nozzle, height of the vane above the tip of the nozzle when the lever is balanced, and distance from the pivot of the lever to the center of the vane.
3. Water is then admitted through the bench supply valve, and the flow rate increased to the maximum. The force on the vane displaces the lever, which is then restored to its balanced position by sliding the jockey weight along the lever. The mass flow rate is established by collection of water over a timed interval.
4. Further observations are then made at a number reducing flow rates. About eight readings should suffice.
5. The best way to set the conditions for reduced flow rate is to place the jockey weight exactly at the desired position, and then to adjust the flow control valve to bring the lever to the balanced position.
6. The condition of balance is thereby found without touching the lever, which is much easier than finding the point of balance by sliding the jockey weight.
7. Moreover, the range of settings of the jockey position may be divided neatly into equal steps.

RESULTS AND CALCULATIONS

Diameter of nozzle, $D = 10.0$ mm

Cross sectional area of nozzle, $A = \pi D^2/4 = 78.5 \text{ mm}^2 = 7.85 \times 10^{-5} \text{ m}^2$

Height of vane above nozzle tip $s = 35$ mm = 0.035 m

Distance from center of vane to pivot of lever = 150 mm

Mass of jockey weight, $M = 0.600$ kg

Weight of jockey weight, $W = Mg$

$$= 0.600 \times 9.81$$

$$= 5.886 \text{ N}$$

When the jockey weight is moved a distance y mm from its zero position, the force F on the vane which is required to restore balance is given by:

$$F \times 150 = W \times y$$

Inserting the value of W , namely 5.89 N, gives $5886 \times y/150$

$$F = 0.03924y \text{ N}$$

The mass flow rate m in the jet is found by timing the collection of a known mass of water. The velocity u_1 of the jet as it leaves the nozzle is found from the volumetric flow rate Q and the cross-sectional area A of the nozzle. The velocity u_0 with which the jet strikes the vane is slightly less than u_1 because of the deceleration due to gravity. This effect may be calculated from the expression

$$\mathbf{u_0^2 = u_1^2 - 2gs}$$

Inserting the value $s = 0.035 \text{ m}$ leads to the result $\mathbf{u_0 = \sqrt{u_1 - 0.687} \text{ m/s}}$

Recorded values of quantity collected, measured time, and jockey displacement y are presented in the table below, together with the ensuing calculations.

In the first line for example,

$$\text{Mass flow rate (m)} = 6/12.67$$

$$= \underline{0.4735596 \text{ Kg/s}}$$

$$\text{Volumetric flow rate (Q)} = 0.4735596 \times 10^{-3} \text{ m}^3/\text{s}$$

$$\text{Velocity at nozzle exit } u_1 = Q/A$$

$$= 0.4735596 \times 10^{-3} / 7.85 \times 10^{-5} \text{ m}^2$$

$$= \underline{6.0326 \text{ m/s}}$$

$$\text{Velocity at impact with vane } \mathbf{u_0 = \sqrt{u_1^2 - 0.687}}$$

$$= 5.97539 \text{ m/s}$$

$$\text{Momentum flow in jet at impact (J)} = 0.4735596 \times 5.97539$$

$$= \underline{2.83 \text{ N}}$$

$$\text{Force on vane (F)} = 0.03924 \times y$$

$$= 0.3924 \times 120$$

$$= \underline{4.7088 \text{ N}}$$

MASS OF WATER COLLECTED (Kg)	Time t (s)	Flow Rate or Q (m ³ /s)	Distance y (mm)	Velocity or u ₁ (m/s)	Velocity or u ₀ (m/s)	Rate of delivery of Momentum (Kgm/s ²)	Force (N)
6	12.67	0.000474	120	<u>6.0326</u>	5.97539	2.8282	<u>4.7088</u>
6	10.82	0.000555	100	7.0605	7.01166	3.8882	3.9240
6	15.35	0.000391	80	4.9768	4.90733	1.9182	3.1392
6	13.55	0.000443	60	5.6380	5.57670	2.4694	2.3544
6	19.75	0.000304	40	3.8681	3.77822	1.1478	1.5696

Results for hemispherical cup for $\beta = 180^\circ$

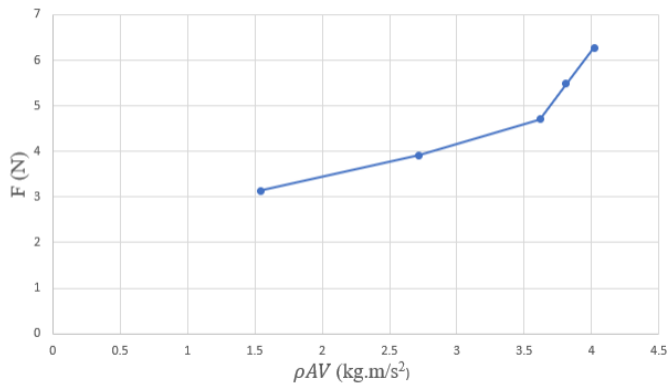

MASS OF WATER	Time t (s)	Flow Rate or Q (m ³ /s)	Distance y or position	Velocity or u ₁ (m/s)	Velocity or u ₀ (m/s)	Rate of delivery of	Force (N)
---------------	------------	------------------------------------	------------------------	----------------------------------	----------------------------------	---------------------	-----------

COLLECTED (Kg)			of jockey (mm)			Momentum (Kgm/s ²)	
6	9.72	0.000617	120	7.8595	7.81568	4.8244	4.7088
6	4.67	0.001285	100	16.359	16.3375	20.9904	3.9240
6	6.38	0.000940	80	11.9703	11.9453	11.2338	3.1392
6	12.10	0.000496	60	6.31358	6.25894	3.10361	2.3544
6	16.43	0.000365	40	4.64969	4.57522	1.67080	1.5696

Results for Flat plate for $\beta = 90^\circ$

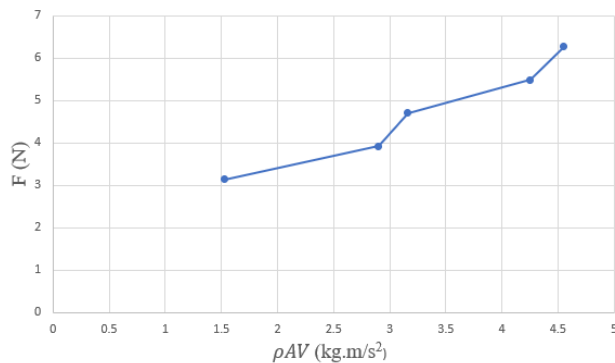

OBSERVATIONS AND DISCUSSION:

It was noticed that the experimental forces are lower than the theoretical forces and this is because of friction in the pipe. As the volumetric rate of flow Q decrease, both the theoretical and experimental forces both decreases, as shown by the plot on the graph.

It was also noted that maximum experimental forces were obtained for the flat vane while the minimum experimental forces were obtained for the hemispherical vane. Some of errors where mainly due to:

- Errors when taking the time reading for the water to fill the tank.
- The nozzle and the vane may not have been concentric, as the cylinder may move around slightly sue to the action of the force of water and must be concentric.
- The water which hits the vane could flow downwards and hit the jet again which will give a momentum in the opposite direction hence false values.
- A change in the height between the nozzle and vane due to the changing of the vanes as all vanes do not have equal weights and heights.
- Parallax error when determining whether the weight beam was horizontal or not.

- Some of the water was leaking from the hydraulic bench.

To reduce the difference between the experimental and theoretical results, the following recommendation can be considered.

- ✓ Taking more than one time reading for each distance on the weight beam and the time should be measured carefully.
- ✓ It is necessary to ensure constant water supply of the pump.
- By the use of a proper timer that can accurately measure the time taken for the water to fill the tank.

CONCLUSION:

The experiment can be said to have been carried out successfully. It was determined the greater the discharge of the jet, the greater the impact force of the fluid. Therefore, the discharge of the fluid is directly proportional to the impact force of the fluid