

**WELCOME TO  
CEE 3211**

**MECHANICS OF  
MATERIALS**

# TIMETABLE

- Tuesday 08:00 – 10:00 venue D1
- Thursday 10:00 – 12:00 Venue D3

# LECTURER

Charles Kahanji

Room 212 – Engineering Main Building

# COURSE Contents

## *Flexural members*

Types of load. Classification of beams. Review of statics. Relation between the intensity of loading, shearing force, and bending moment in a straight beam.

Pure bending of beams. Shearing stresses in Beams. Distribution of shear stresses in a thin-walled section. Shear centre. Analysis of stresses and strains at a point. Elastic strain energy of bending Beams of composite materials.

## *Torsion*

Deformations and stresses in circular shafts. Solid non-circular members. Deflection and stresses in closely coiled helical springs. Strain energy of elastic torsion.

## *Compound Stresses*

Superposition of stresses and its limitations. Unsymmetrical bending. Combined bending and direct stresses. Thin-walled pressure vessels. Combined bending and torsion.

# COURSE Contents cont'd

## *Structural connections*

Eccentrically bolted and welded connections.

Theories of failure

Maximum Principal stress theory (Rankine), Maximum shear stress (Tresca and Haigh), Strain Energy Theory (Haigh), Shear Strain Energy Theory (Von Mises and Hencky), and Maximum Principle Strain Theory (St. Venant).

## *Deflection of beams*

Differential equations for deflection of elastic beams. Solution of beam deflection problems by direct integration, Virtual work/unit load method, Moment-Area Method, Conjugate-beam method. Simple statically indeterminate beams. Impact loads. Deflection of trusses.

# COURSE Contents cont'd

## *Elastic buckling of columns*

Stability of equilibrium. Analysis of buckling behaviour. Flexural Buckling of a pin-ended strut. Generalised Euler formula and limitations. Strut with eccentric load. Secant formula. Perry-Robertson formula. Strut with lateral load.

## *Plastic theory of bending*

Assumptions in the plastic theory, Plastic hinge, Moment of resistance at a plastic hinge. Collapse load and Load Factor. Regions of plasticity. Combined bending and direct stress. Limit analysis of beams.

<b>Component of assessment</b>	<b>Number</b>	<b>Contribution overall grading (%)</b>
<b>QUIZES</b>		10
<b>Laboratory</b>	5	10
<b>Test</b>	1	20
<b>Continuous assessment</b>		40
<b>Final examination</b>	1	60

## **Prescribed Books**

1. Gere JM and Goodno BJ, 2009, Mechanics of Materials, 7<sup>th</sup> Edition, Cengage Learning, ISBN 13:978-0-495-43807-6, ISBN 10: 0-495-43807-3

## **Recommended Books**

1. Case J. and Chilver, A.H. Strength of materials and structures, 2nd edition, Edward Arnold, 1988.
2. Popov, E.P., Mechanics of materials, 2nd edition, Prentice Hall International Editions, 1978
3. Ryder G.H., Strength of Materials 3rd Edition, Macmillan (ELBS), 1983, London.
4. Todd J D., Structural Theory and Analysis 2nd Edition, Macmillan, 1981

# **LECTURE 1**

# ***MECHANICS***

The physical science that deals with the conditions of rest or motion of bodies acted on by forces or by thermal disturbances

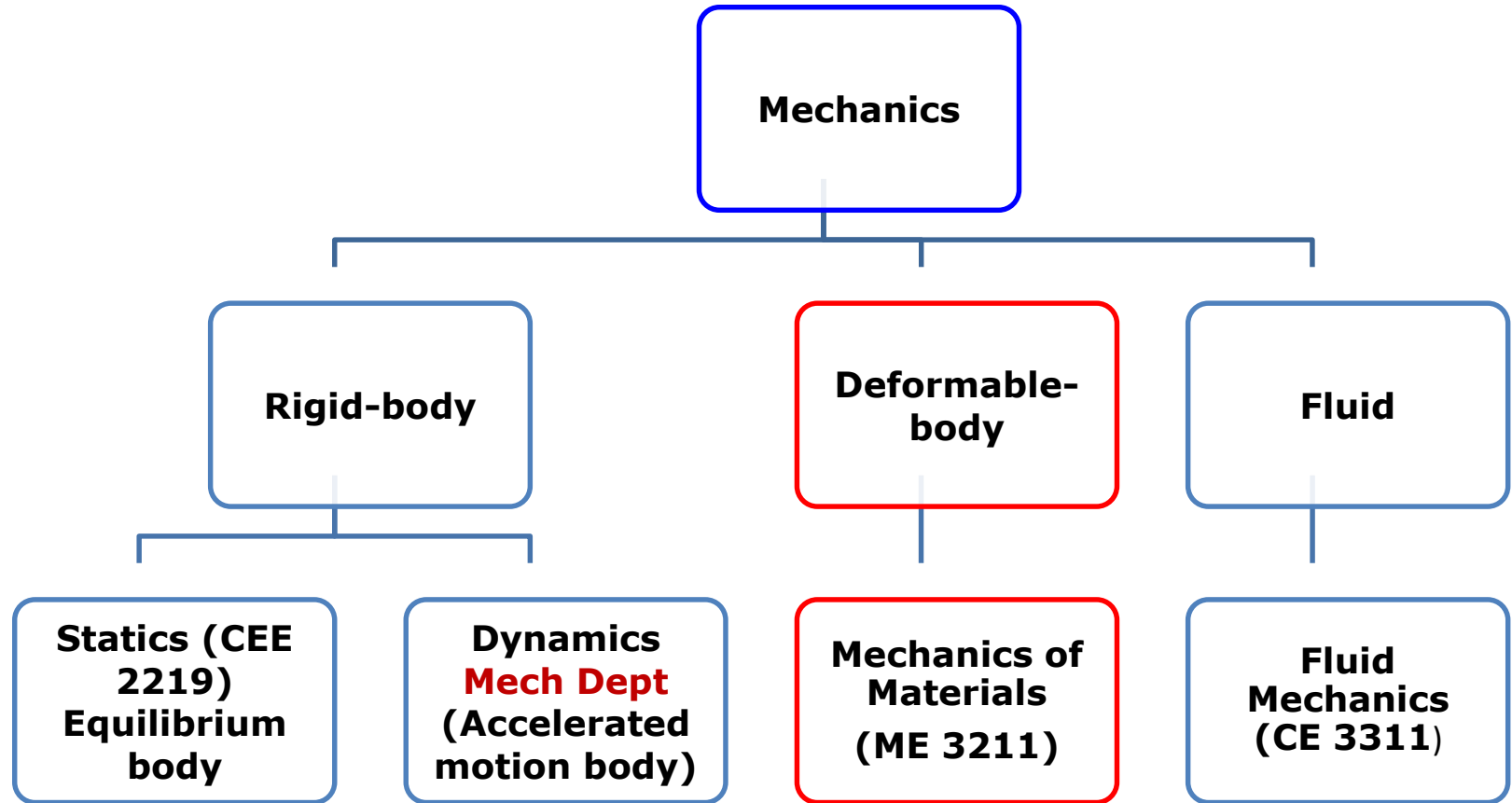
## **MECHANICS of MATERIALS**

A branch of mechanics that studies the internal effects and strain in a solid body that is subjected to an external loading

**MECHANICS of MATERIALS** is a topic that is also known by several other names, including:

- ***STRENGTH OF MATERIALS***
- ***MECHANICS OF SOLIDS***
- ***MECHANICS OF DEFORMABLE BODIES***

# AREAS OF MECHANICS



The mechanics of deformable solids is more concerned with the internal forces and associated changes in the geometry of the components involved.

A **deformable body** is a solid that changes size and/or shape as a result of loads that are applied to it or as a result of temperature changes.

# Concept of Stress

- The main objective of the study of mechanics of materials is to provide the future engineer with the means of **analyzing** and **designing** various load bearing structures.
- Both the analysis and design of a given structure involve the determination of *stresses* and *deformations*.
- The two most important concepts in Mechanics of Materials are the concepts of **stress** and **strain**.

# Concept of Stress

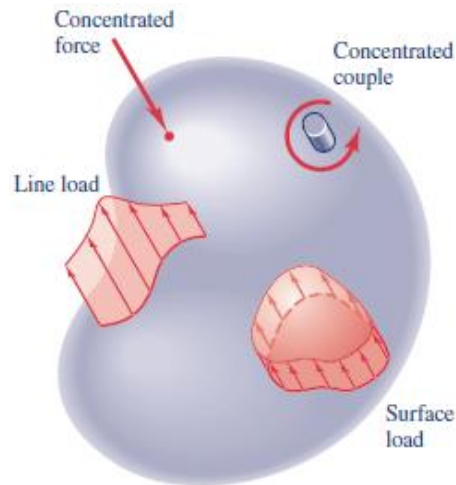
Three *fundamental types of equations* that are used in solving strength and stiffness problems of deformable-body mechanics will be stressed repeatedly. They are:

1. The **equilibrium** conditions must be satisfied.
2. The **geometry of deformation** must be described.
3. The **material behaviour** (i.e., the force-temperature-deformation relationships of the materials) must be characterized.

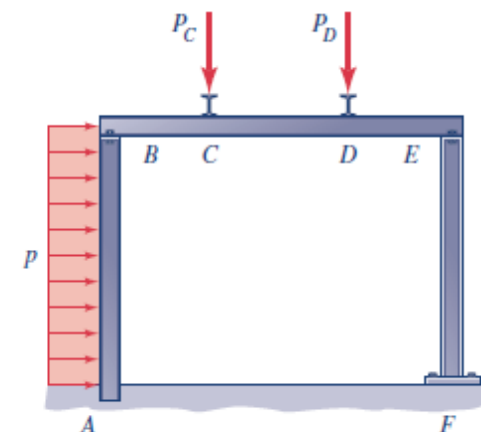
# TYPES OF LOADS

**External Loads.** The **external loads** acting on a deformable body are known as force and moments. They may be classified in four categories, or types. These types, together with their appropriate dimensions, are:

- **Concentrated loads, including point forces ( $F$ ) and couples ( $F L$ )** (If area is small in comparison to total surface area of body)
- **Line loads ( $F/L$ )** – (if the load is applied along a narrow strip of area)
- **Surface loads ( $F/L^2$ )** – (due to direct contact of one body with surface of another)
- **Body forces ( $F/L^3$ )** – (exertion of force on a body by another without direct physical contact)



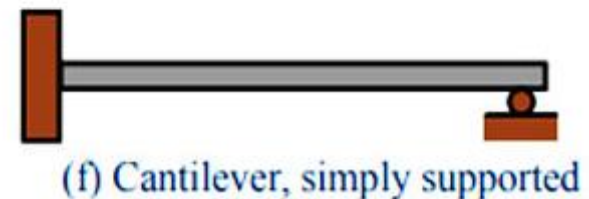
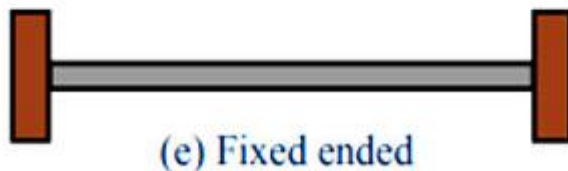
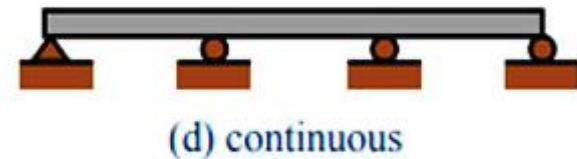
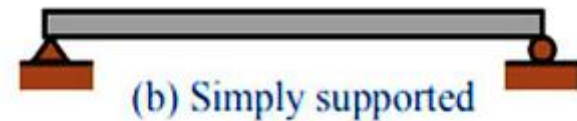
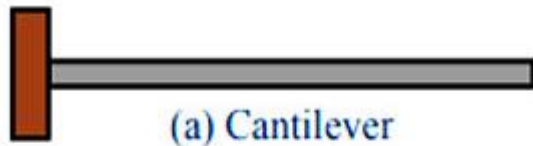
(a) A generic deformable body.



(b) A portal frame.

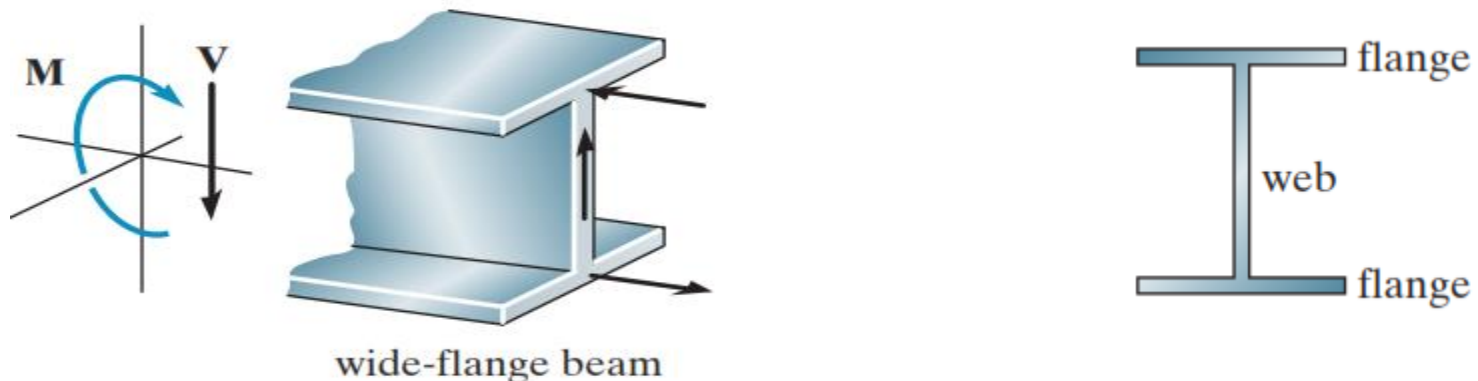
# CLASSIFICATION OF BEAMS

- **Beams** are usually straight horizontal members used primarily to carry vertical loads.
- Beams are primarily designed to resist bending moment;
- They are classified according to the way they are supported as shown:



# CLASSIFICATION OF BEAMS

- When the material used for a beam is a metal such as steel, the cross section is most efficient when it is shaped as shown in Fig. below.
- Here the force developed in the top and bottom *flanges of the beam form the necessary* couple used to resist the applied moment  $M$ , whereas the *web is effective* in resisting the applied shear  $V$ . **This cross section is commonly referred to as a “wide flange,”**
- If shorter lengths are needed, a cross section having tapered flanges is sometimes selected.
- When the beam is required to have a very large span and the loads applied are rather large, the cross section may take the form of a *plate girder*.



# REVIEW OF STATIC EQUILIBRIUM; EQUILIBRIUM OF DEFORMABLE BODIES

Consider deformable bodies at rest. In your previous CEE2219 course, you learned the equations of equilibrium and you learned how to apply these equations to particles and to rigid bodies through the use of free-body diagrams.

$$\sum F_x = 0, (\Sigma M)_O = 0$$

That is, if a body is in equilibrium,

- the sum of the external forces acting on the body is zero, and
- the sum of the moments, about any arbitrary point  $O$ , of all the external forces acting on the body is zero.

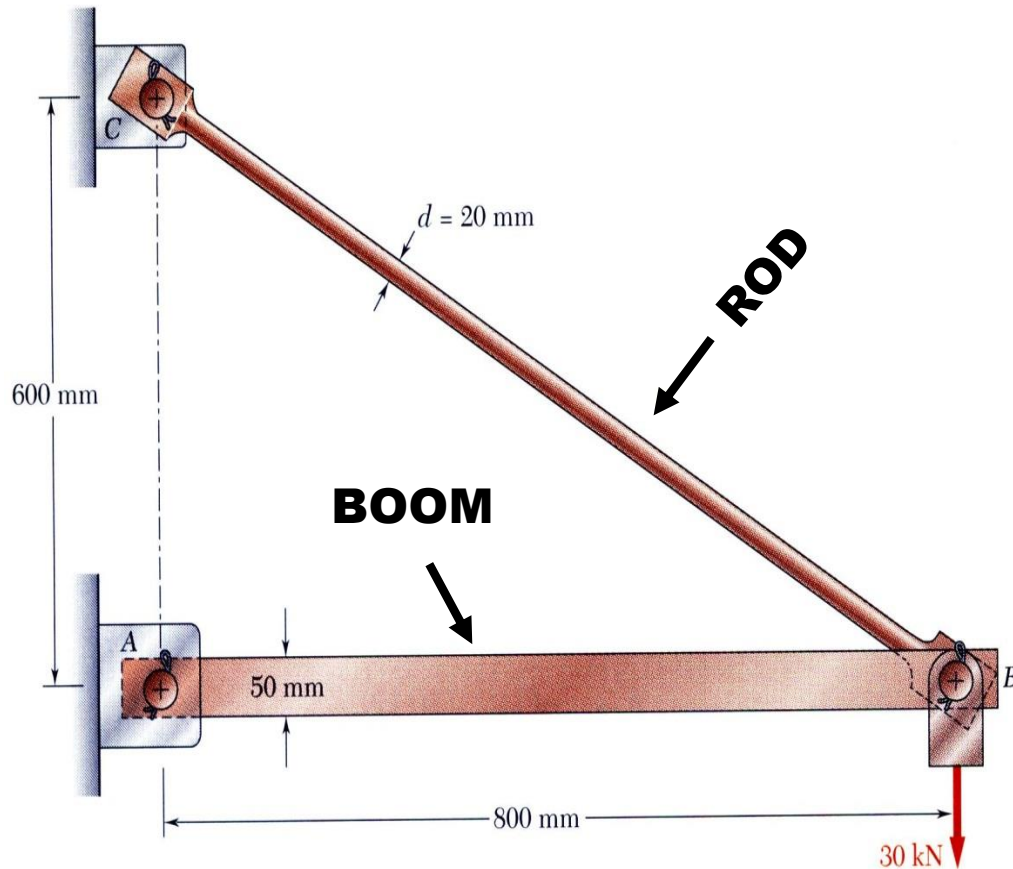
In order to apply equilibrium equations to a body, it is always wise to draw a FBD

$$\sum F_x = 0, (\Sigma M_x)_O = 0$$

$$\sum F_y = 0, (\Sigma M_y)_O = 0$$

$$\sum F_z = 0, (\Sigma M_z)_O = 0$$

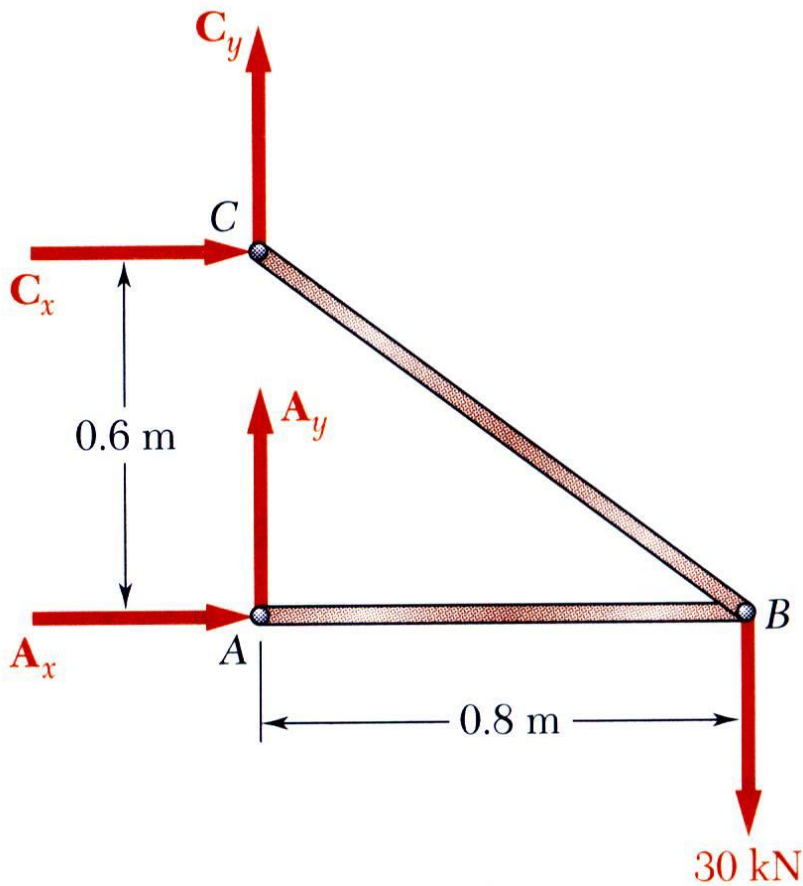
# Review of Statics



- The structure is designed to support a 30 kN load
- The structure consists of a boom and rod joined by pins (zero moment connections) at the junctions and supports
- Perform a static analysis to determine the internal force in each structural member and the reaction forces at the supports

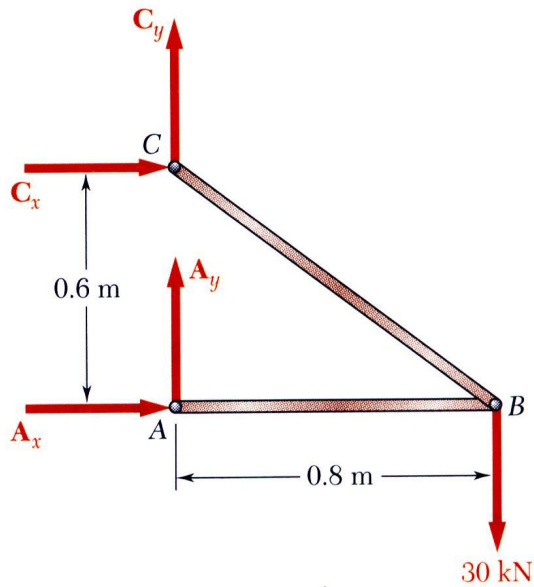
# Structure Free-Body Diagram

- Structure is detached from supports and the loads and reaction forces are indicated



- Conditions for static equilibrium:
$$\sum M_C = 0 = A_x(0.6\text{ m}) - (30\text{ kN})(0.8\text{ m})$$
$$A_x = 40\text{ kN} \longrightarrow \text{Eqn. (a)}$$
$$\sum F_x = 0 = A_x + C_x$$
$$C_x = -A_x = -40\text{ kN} \longrightarrow \text{Eqn. (b)}$$
$$\sum F_y = 0 = A_y + C_y - 30\text{ kN} = 0$$
$$A_y + C_y = 30\text{ kN} \longrightarrow \text{Eqn. (c)}$$
- $A_y$  and  $C_y$  can not be determined from these equations

# Component Free-Body Diagram

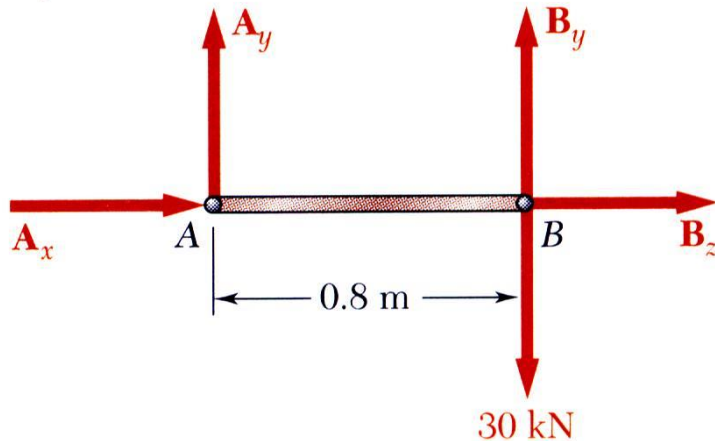


- In addition to the complete structure, each component must satisfy the conditions for static equilibrium
- Consider a free-body diagram for the **boom**:  

$$\sum M_B = 0 = -A_y(0.8\text{ m})$$

$$A_y = 0$$
 substitute into the structure equilibrium equation i.e Eqn (c).

$$C_y = 30\text{ kN}$$

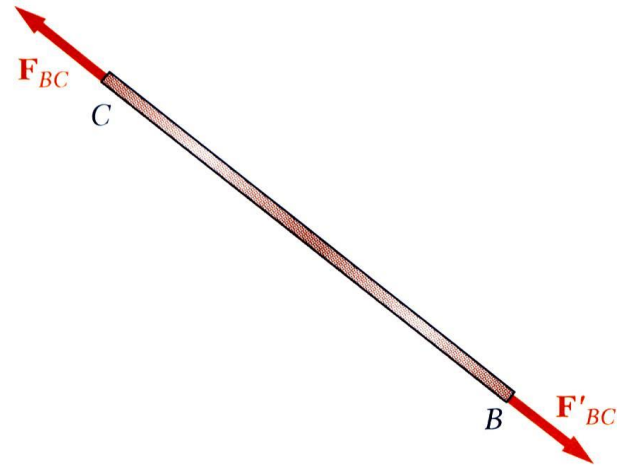


- Results:  

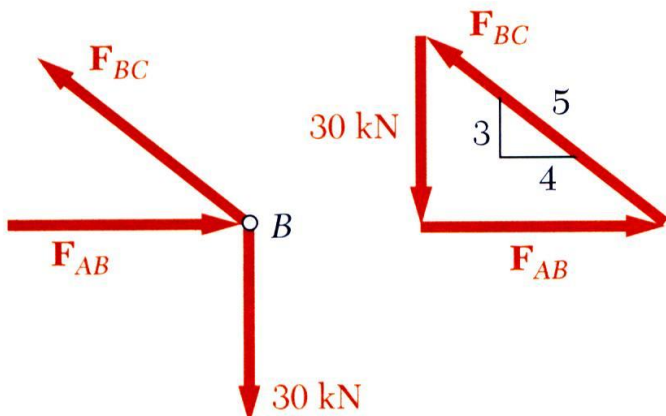
$$A = 40\text{ kN} \rightarrow \quad C_x = 40\text{ kN} \leftarrow \quad C_y = 30\text{ kN} \uparrow$$
 Reaction forces are directed along boom and rod

# Internal Forces (Method of Joints)

- The boom and rod are 2-force members, i.e., the members are subjected to only two forces which are applied at member ends
- For equilibrium, the forces must be parallel to an axis between the force application points, equal in magnitude, and in opposite directions



- Joints must satisfy the conditions for static equilibrium which may be expressed in the form of a force triangle:

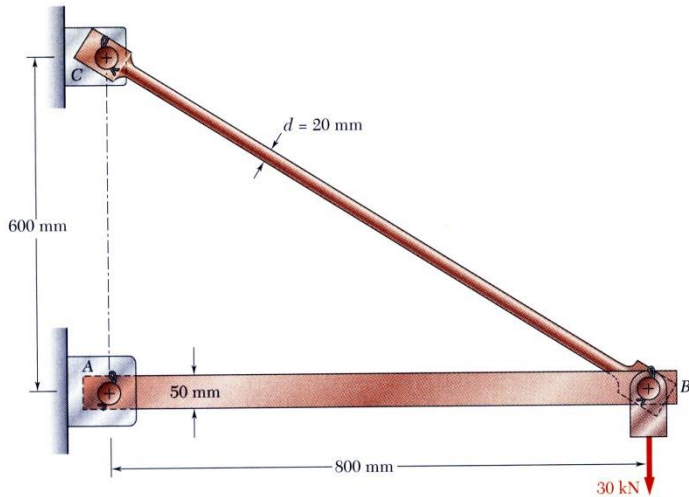


$$\sum \vec{F}_B = 0$$

$$\frac{F_{AB}}{4} = \frac{F_{BC}}{5} = \frac{30 \text{ kN}}{3}$$

$$F_{AB} = 40 \text{ kN} \quad F_{BC} = 50 \text{ kN}$$

# Stress Analysis



$$d_{BC} = 20 \text{ mm}$$

Can the structure safely support the 30 kN load?

- From a statics analysis

$$F_{AB} = 40 \text{ kN (compression)}$$

$$F_{BC} = 50 \text{ kN (tension)}$$

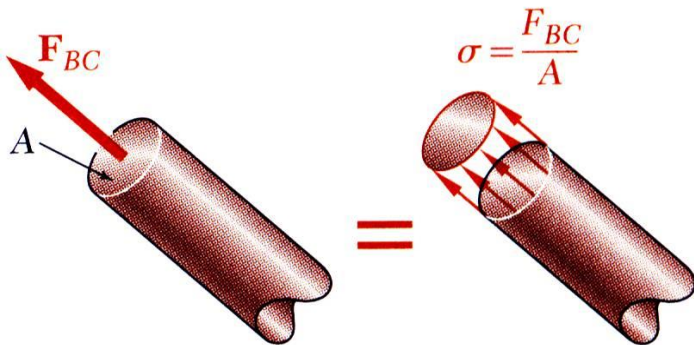
- At any section through member BC, the internal force is 50 kN with a force intensity or stress of

$$\sigma_{BC} = \frac{P}{A} = \frac{50 \times 10^3 \text{ N}}{314 \times 10^{-6} \text{ m}^2} = 159 \text{ MPa}$$

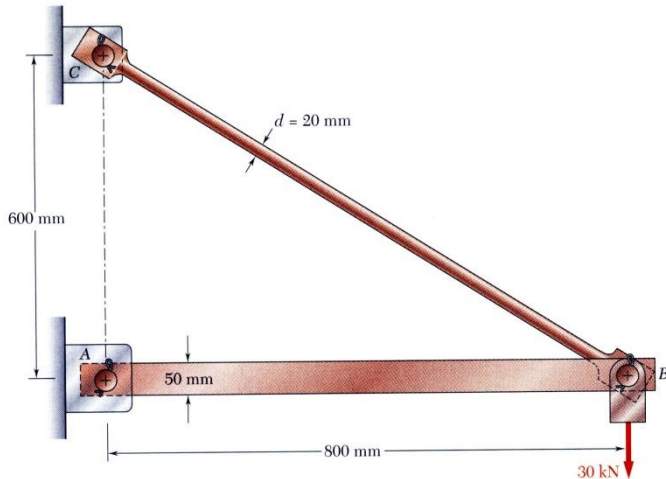
- From the material properties for steel, the allowable stress is

$$\sigma_{\text{all}} = 165 \text{ MPa}$$

- Conclusion: the strength of member BC is adequate



# Design



- Design of new structures requires selection of appropriate materials and component dimensions to meet performance requirements
- For reasons based on cost, weight, availability, etc., the choice is made to construct the rod from aluminum ( $\sigma_{all} = 100 \text{ MPa}$ ). What is an appropriate choice for the rod diameter?

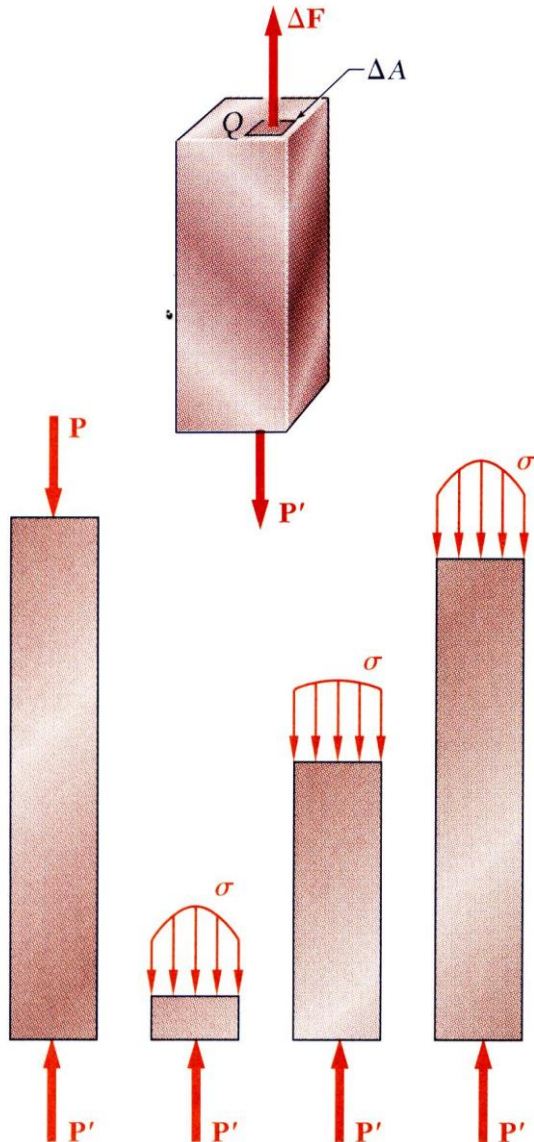
$$\sigma_{all} = \frac{P}{A} \quad A = \frac{P}{\sigma_{all}} = \frac{50 \times 10^3 \text{ N}}{100 \times 10^6 \text{ Pa}} = 500 \times 10^{-6} \text{ m}^2$$

$$A = \pi \frac{d^2}{4}$$

$$d = \sqrt{\frac{4A}{\pi}} = \sqrt{\frac{4(500 \times 10^{-6} \text{ m}^2)}{\pi}} = 2.52 \times 10^{-2} \text{ m} = 25.2 \text{ mm}$$

- An aluminum rod 26 mm or more in diameter is adequate

# Axial Loading: Normal Stress



- The resultant of the internal forces for an axially loaded member is *normal* to a section cut perpendicular to the member axis.
- The force intensity on that section is defined as the normal stress.

$$\sigma = \lim_{\Delta A \rightarrow 0} \frac{\Delta F}{\Delta A} \quad \sigma_{ave} = \frac{P}{A}$$

- The normal stress at a particular point may not be equal to the average stress but the resultant of the stress distribution must satisfy

$$P = \sigma_{ave} A = \int dF = \int_A \sigma dA$$

- The detailed distribution of stress is statically indeterminate, i.e., can not be found from statics alone.

# Factor of Safety

Structural members or machines must be designed such that the working stresses are less than the ultimate strength of the material.

$FS$  = Factor of safety

$$FS = \frac{\sigma_u}{\sigma_{all}} = \frac{\text{ultimate stress}}{\text{allowable stress}}$$

$$FS = \frac{\text{Failure Load}}{\text{allowable Load}}$$

$$FS > 1$$

Factor of safety considerations:

- uncertainty in material properties
- uncertainty of loadings
- uncertainty of analyses
- number of loading cycles
- types of failure
- maintenance requirements and deterioration effects
- importance of member to structures integrity
- risk to life and property
- influence on machine function

# Stress & Strain: Axial Loading

- Suitability of a structure or machine may depend on the deformations in the structure as well as the stresses induced under loading. Statics analyses alone are not sufficient.
- Considering structures as deformable allows determination of member forces and reactions which are statically indeterminate.
- Determination of the stress distribution within a member also requires consideration of deformations in the member.
- Concerned with deformation of a structural member under axial loading.

# Normal Strain

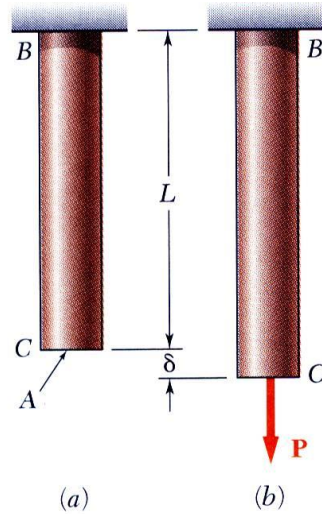


Fig. 2.1

$$\sigma = \frac{P}{A} = \text{stress}$$

$$\varepsilon = \frac{\delta}{L} = \text{normal strain}$$

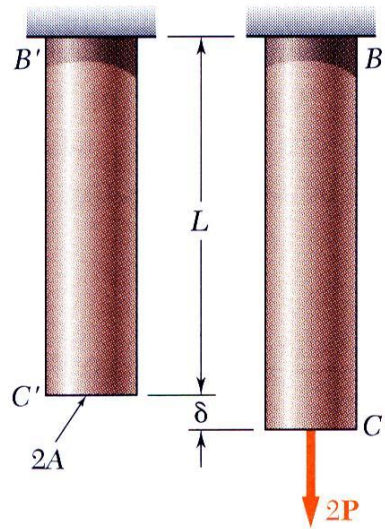


Fig. 2.3

$$\sigma = \frac{2P}{2A} = \frac{P}{A}$$

$$\varepsilon = \frac{\delta}{L}$$

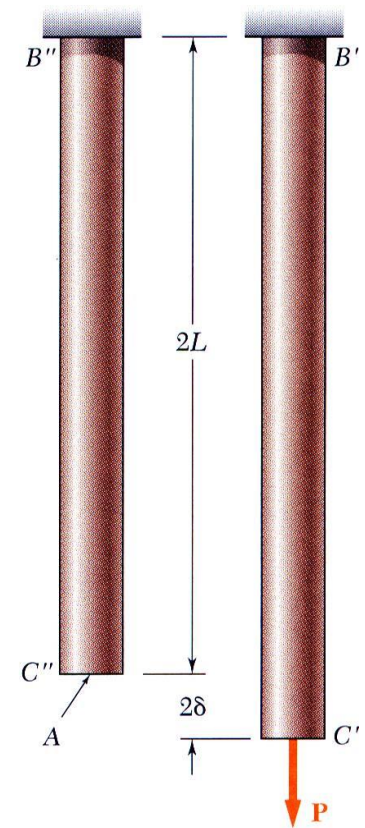
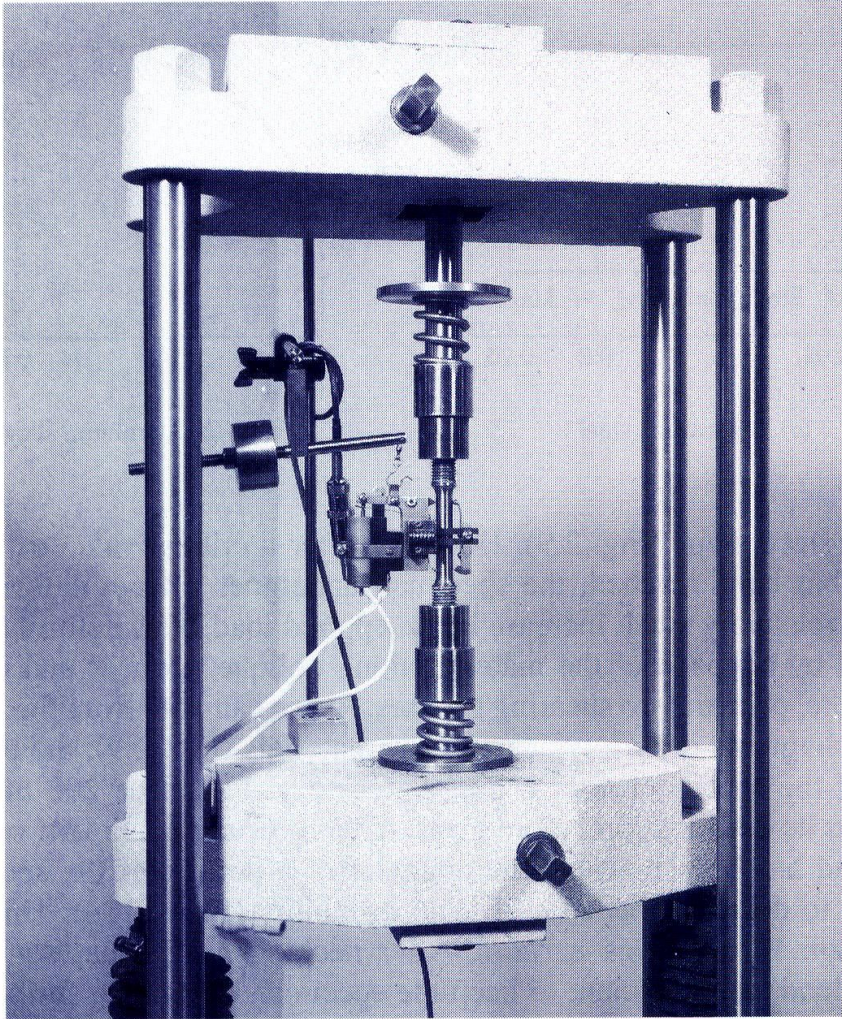


Fig. 2.4

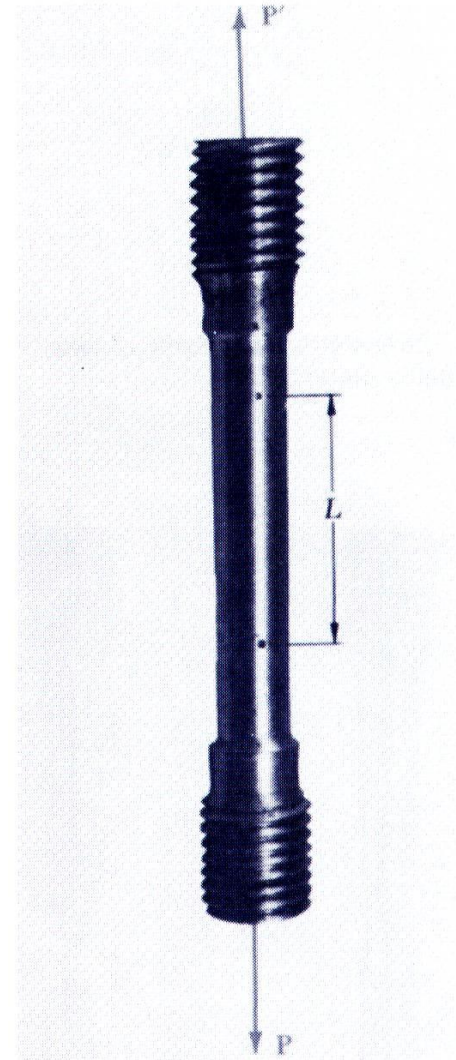
$$\sigma = \frac{P}{A}$$

$$\varepsilon = \frac{2\delta}{2L} = \frac{\delta}{L}$$

# Stress-Strain Test

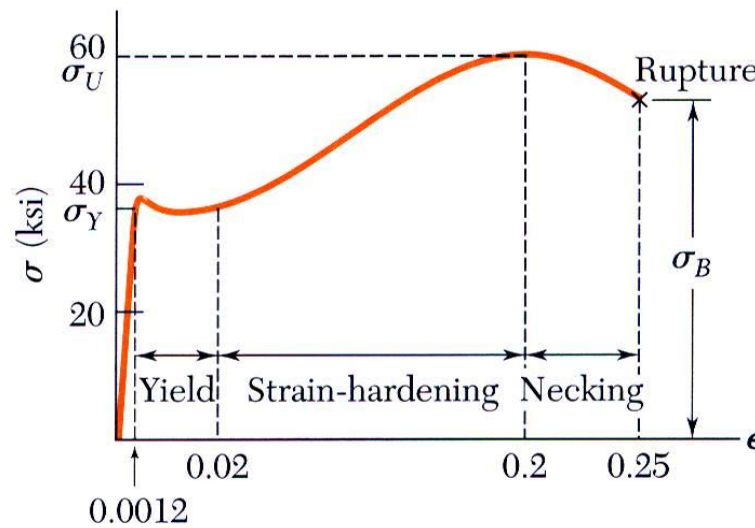
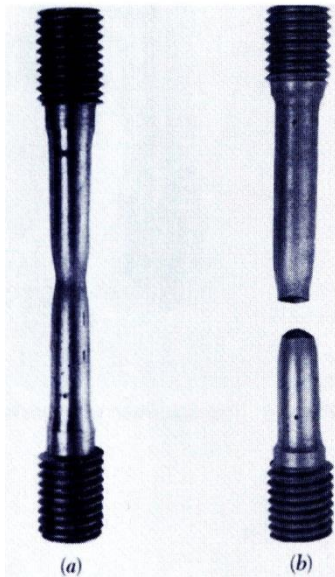


**Fig. 2.7** This machine is used to test tensile test specimens, such as those shown in this chapter.

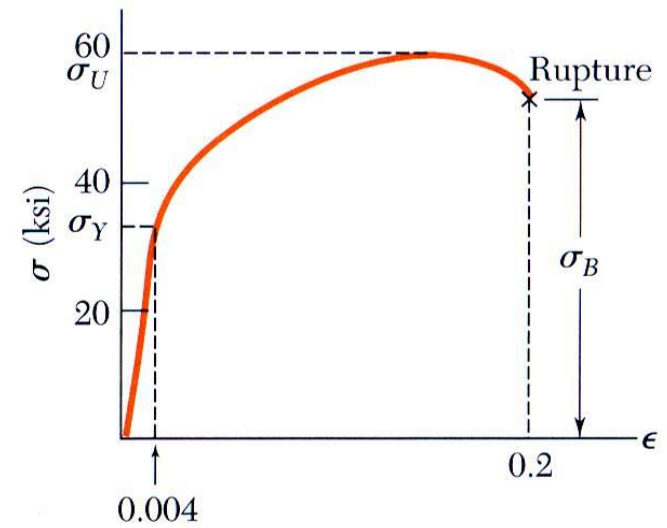


**Fig. 2.8** Test specimen with tensile load.

# Stress-Strain Diagram: Ductile Materials

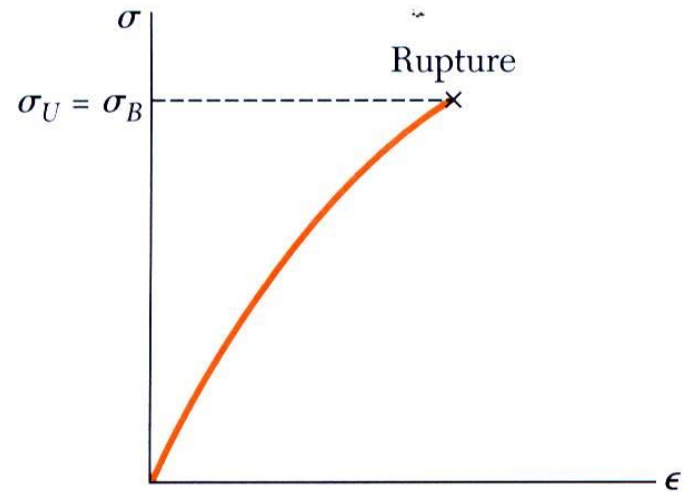
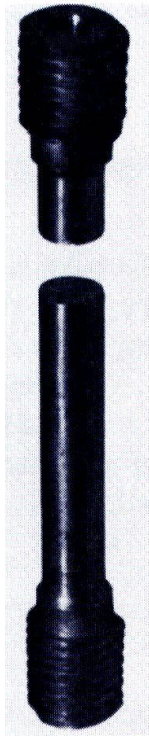


(a) Low-carbon steel



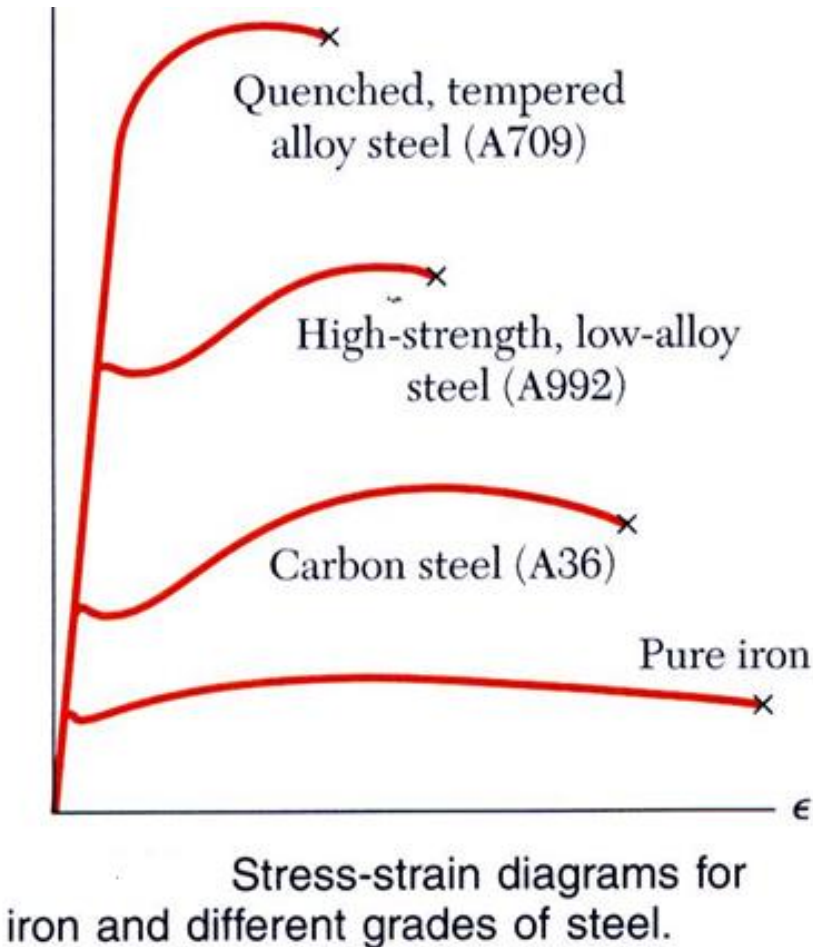
(b) Aluminum alloy

# Stress-Strain Diagram: Brittle Materials



**Fig. 2.11** Stress-strain diagram for a typical brittle material.

# Hooke's Law: Modulus of Elasticity



- Below the yield stress

$$\sigma = E\epsilon$$

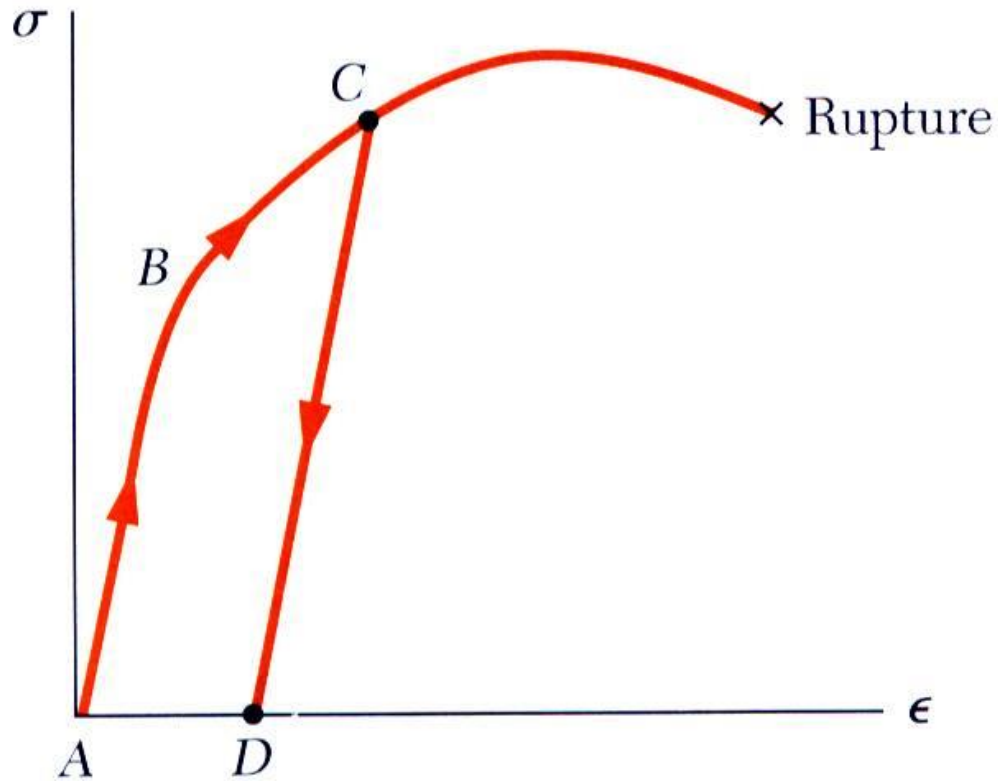
$E$  = Young's Modulus or  
Modulus of Elasticity

All the 4 steel grades, possess the same modulus of elasticity; in other words, their “stiffness,” or ability to resist a deformation within the linear range, is the same

Therefore, if a high-strength steel is substituted for a lower-strength steel in a given structure, and if all dimensions are kept the same, the structure will have an increased load-carrying capacity, but its stiffness will remain unchanged

Strength is affected by alloying, heat treating, and manufacturing process but stiffness (Modulus of Elasticity) is not.

# Elastic vs. Plastic Behavior



**Fig. 2.18**

- If the strain disappears when the stress is removed, the material is said to behave *elastically*.
- The largest stress for which this occurs is called the *elastic limit*.
- When the strain does not return to zero after the stress is removed, the material is said to behave *plastically*.

# Deformations Under Axial Loading

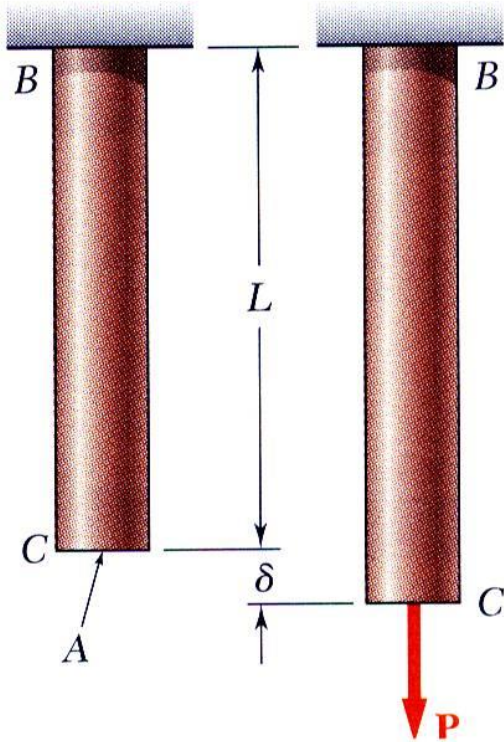


Fig. 2.22

- From Hooke's Law:

$$\sigma = E\varepsilon \quad \varepsilon = \frac{\sigma}{E} = \frac{P}{AE}$$

- From the definition of strain:

$$\varepsilon = \frac{\delta}{L}$$

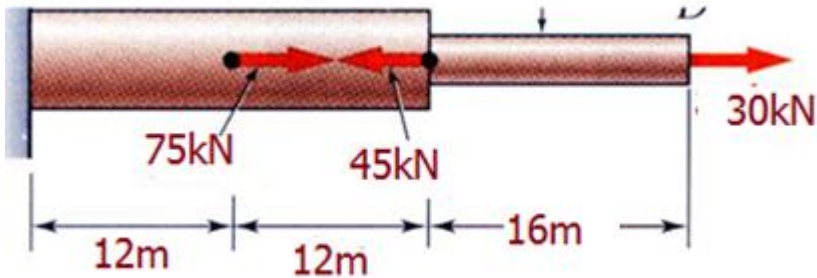
- Equating and solving for the deformation,

$$\delta = \frac{PL}{AE}$$

- With variations in loading, cross-section or material properties,

$$\delta = \sum_i \frac{P_i L_i}{A_i E_i}$$

# Example 1



$$E = 200GPA$$

$$D = 1.07 \text{ m. } d = 0.618 \text{ m.}$$

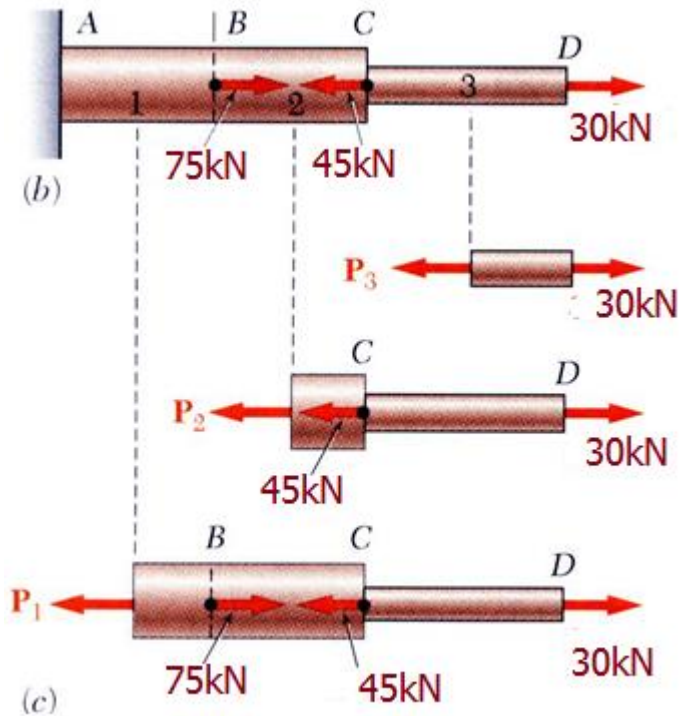
Determine the deformation of the steel rod shown under the given loads.

SOLUTION:

- Divide the rod into components at the load application points.
- Apply a free-body analysis on each component to determine the internal force
- Evaluate the total of the component deflections.

## SOLUTION:

- Divide the rod into three components:



- Apply free-body analysis to each component to determine internal forces,

$$P_1 = 60 \times 10^3 \text{ N}$$

$$P_2 = -15 \times 10^3 \text{ N}$$

$$P_3 = 30 \times 10^3 \text{ N}$$

- Evaluate total deflection,

$$\begin{aligned} \delta &= \sum_i \frac{P_i L_i}{A_i E_i} = \frac{1}{E} \left( \frac{P_1 L_1}{A_1} + \frac{P_2 L_2}{A_2} + \frac{P_3 L_3}{A_3} \right) \\ &= \frac{1}{200 \times 10^9} \left[ \frac{(60 \times 10^3) 12}{0.9} + \frac{(-15 \times 10^3) 12}{0.9} \right. \\ &\quad \left. + \frac{(30 \times 10^3) 16}{0.3} \right] \\ &= 0.011 \text{ mm.} \end{aligned}$$

$$\delta = 0.011 \text{ mm.}$$

$$L_1 = L_2 = 12 \text{ m.} \quad L_3 = 16 \text{ m}$$

$$A_1 = A_2 = 0.9 \text{ m}^2 \quad A_3 = 0.3 \text{ m}^2$$

## 2019 EXAM QUESTION

A composite rod has 3 segments shown in Fig Q1. The diameters for each segment are given as;  $AB = 120 \text{ mm}$ ,  $BC = 90 \text{ mm}$  and  $CD = 60 \text{ mm}$ .  $AB$  is made of A-36 structural Steel ( $E = 200 \text{ GPa}$ ),  $BC$  is made of Aluminium ( $E = 68.9 \text{ GPa}$ ) while  $CD$  is made of Brass-C83400 ( $E = 101 \text{ GPa}$ ). The lengths of the segments are as follows:  $AB = 30 \text{ cm}$ ,  $BC = 35 \text{ cm}$  and  $CD = 45 \text{ cm}$ . Determine the following:

- The reaction force at support A **[2 marks]**
- The normal stress induced in each segment **[10 Marks]**
- The total elongation **[8 Marks]**

