



**THE UNIVERSITY OF ZAMBIA
SCHOOL OF ENGINEERING
DEPARTMENT OF MECHANICAL
ENGINEERING**

**MEC 2309 – PROPERTIES OF ENGINEERING
MATERIALS I**

GMM/FKC 2022

LECTURE 4

The background of the slide is split into two vertical panels. The left panel features a light gray background with several realistic water droplets of various sizes scattered across it. The right panel shows a close-up, shallow depth-of-field photograph of a laboratory setting. In the foreground, a glass beaker contains a yellowish liquid. Behind it, several blue plastic pipette tips are visible, some in focus and others blurred. The overall lighting is bright and clean, typical of a scientific or educational presentation.

CRYSTALLOGRAPHIC POINTS, DIRECTIONS, AND PLANES

GM

G. M. MUNAKAAMPE / F. K. CHITALU (2022)

CRYSTALLOGRAPHIC POINTS, DIRECTIONS, AND PLANES

- Physical properties depend more on shape and atomic arrangement of the unit cell than upon which atoms are present.
- When dealing with crystalline materials, it often becomes necessary to specify a particular point within a unit cell, a crystallographic direction, or some crystallographic plane of atoms.
- For some crystal systems—namely, hexagonal, rhombohedral, monoclinic, and triclinic—the three axes are not mutually perpendicular, as in the familiar Cartesian coordinate scheme.
- However, our discussion will be limited to the **Cubic Crystal System and the Hexagonal Crystal System.**

MILLER INDEX NOTATION

- Three numbers or indices are used to designate point locations, directions, and planes.
- The basis for determining index values is the unit cell, with a coordinate system consisting of three (x, y, and z) axes coinciding with the unit cell edges.
- Many properties also vary with crystallographic direction. Therefore, the need to also specify various planes of atoms and directions within the crystal \Rightarrow hence ***Miller Index Notation***.
- **Miller Indices** - A shorthand notation to describe certain crystallographic directions and planes in a material

LATTICE POINTS (POINT COORDINATES)

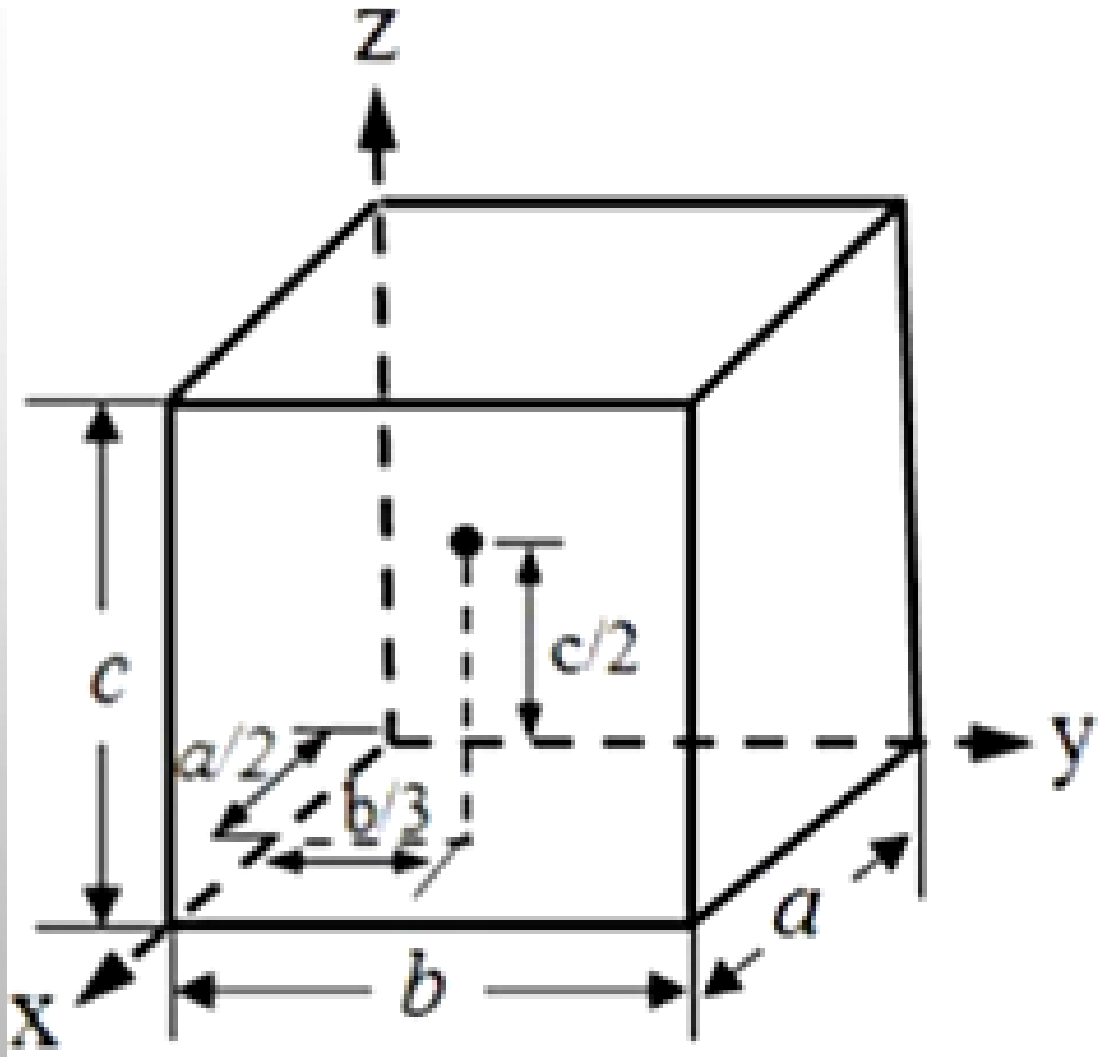

- Position of any point in a unit cell is given by its coordinates or distances on the x, y and z axes in terms of the lattice vectors a, b and c.
- Thus the point located at $a/2$ along the x-axis, $b/3$ along the y-axis and $c/2$ on the z-axis, as shown in the figure, has the coordinates: $\frac{1}{2}, \frac{1}{3}, \frac{1}{2}$.

CRISTALLOGRAPHIC DIRECTIONS

INDICES OF CRYSTAL DIRECTIONS

Direction = defined as successive motion parallel to each of the three axes necessary to move from the origin to another point, which lies in the required line of the resultant motion.

CRISTALLOGRAPHIC DIRECTIONS

- Lattice directions are in direct space and are denoted by $[]$ brackets. A negative number is represented by a bar over the number.
- Directions of a form (also called family) - Crystallographic directions that all have the same characteristics, although their “sense” may be different. Denoted by $\langle \rangle$ brackets, they are symmetrically equivalent

CRISTALLOGRAPHIC DIRECTIONS

Directions in the Cubic System

- The directions in a crystal are given by specifying the coordinates (u, v, w) of a point on a vector (r_{uvw}) passing through the origin, $r_{uvw} = ua + vb + wc$. It is indicated as $[uvw]$.
- For example, the direction $[110]$ lies on a vector r_{110} whose projection lengths on x and y axes are one unit (in terms of unit vectors \mathbf{a} and \mathbf{b}).
- Directions of a form or family like $[110]$, $[101]$, $[011]$ are written as $\langle 110 \rangle$ (using caret $\langle \rangle$).
- Reciprocals are not used in indices of direction.

CRISTALLOGRAPHIC DIRECTIONS

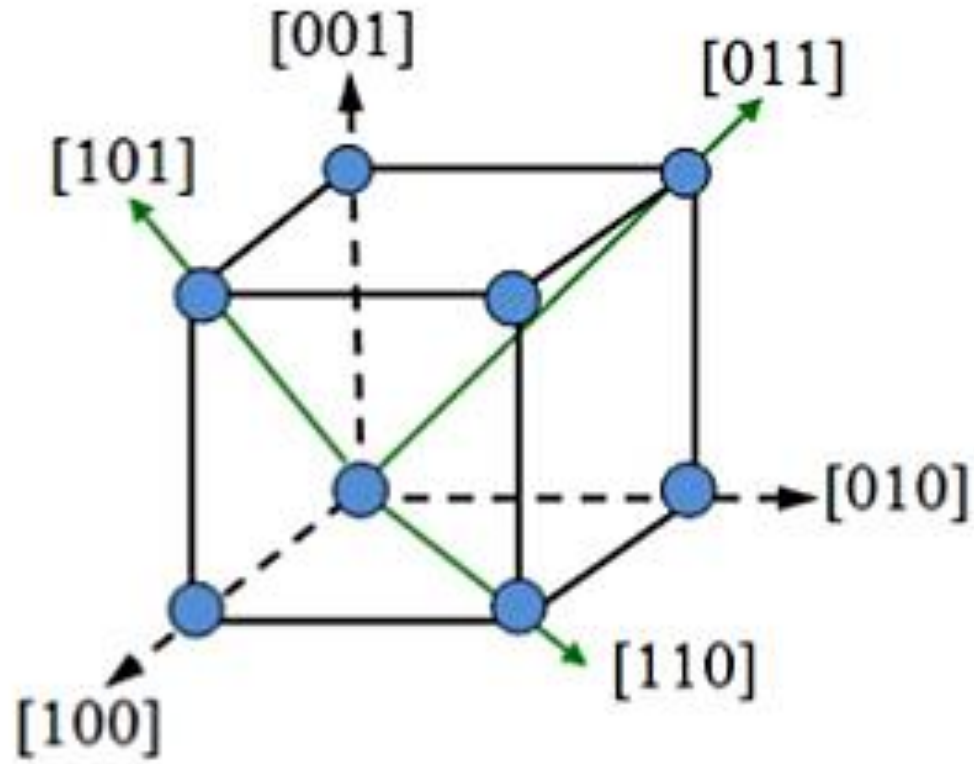

$\langle 110 \rangle$ = Family of directions of face diagonals

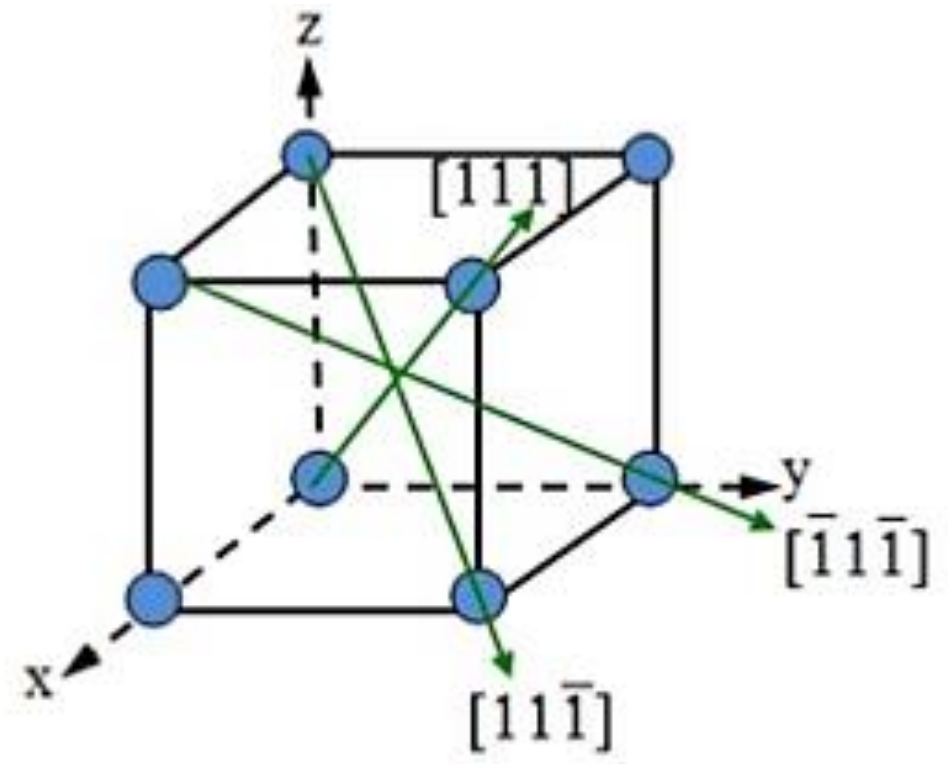

$\langle 111 \rangle$ = Family of directions of major diagonals

CRISTALLOGRAPHIC DIRECTIONS

- The line which passes through uvw will also pass through points $2u2v2w$ and $\frac{1}{2}u \frac{1}{2}v \frac{1}{2}w$.
- Hence $[uvw]$, $[2u2v2w]$ and $[\frac{1}{2}u \frac{1}{2}v \frac{1}{2}w]$ are the same and written as $[uvw]$.
- Fractions are converted in to integers (as shown in the figure below) and reduced to lowest terms.

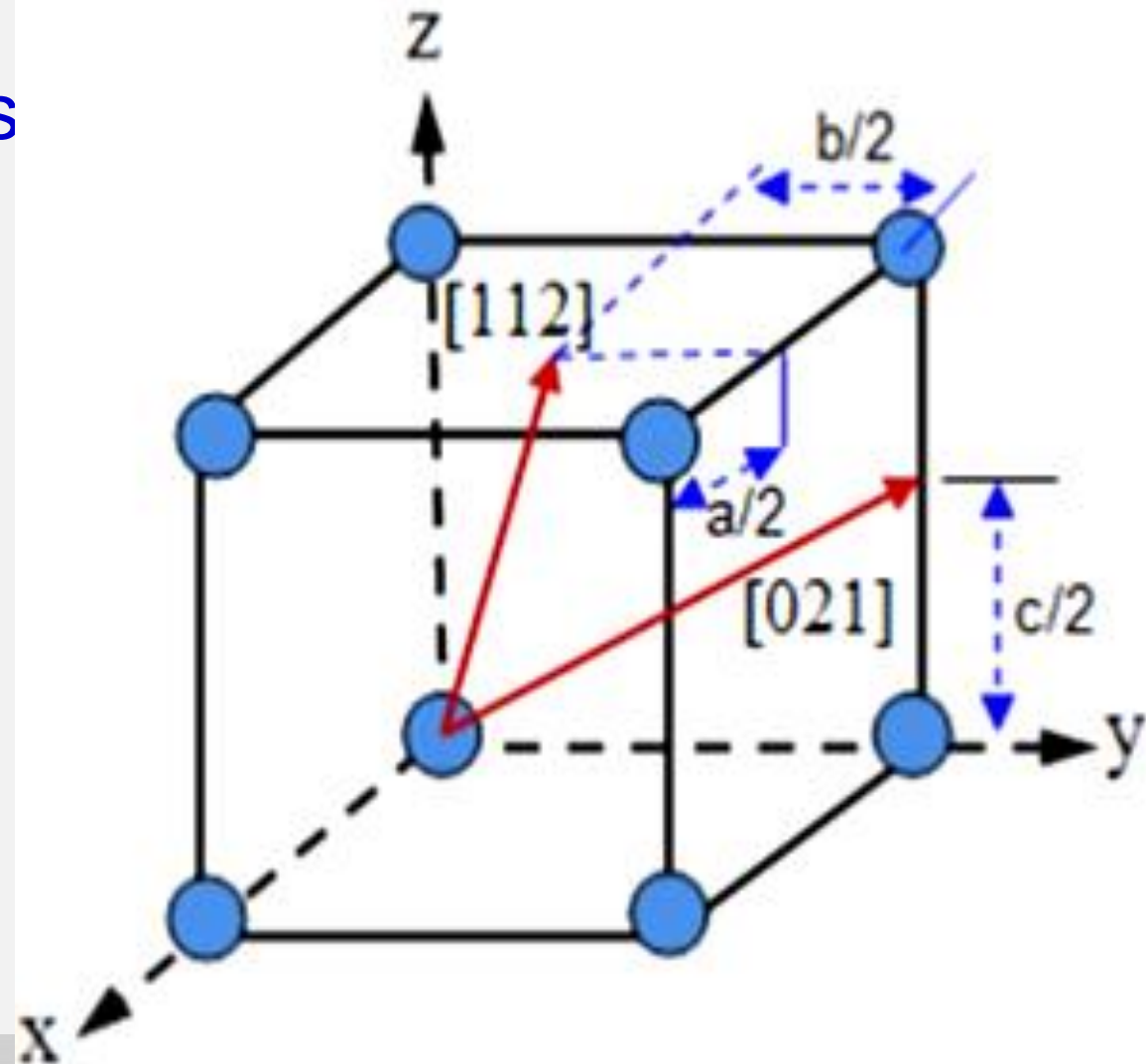

DETERMINING MILLER INDICES OF DIRECTIONS

- To determine a direction of a line in the crystal:
 - Find the coordinates of the two ends of the line and subtract the coordinates (Head to Tail) OR draw a line from the origin parallel to the line and find its projection lengths on x , y and z axis in terms of the unit vectors **a**, **b** and **c**.
 - Convert fractions, if any, in to integers and reduce to lowest term.
 - Enclose in square brackets $[uvw]$

DETERMINING MILLER INDICES OF DIRECTIONS

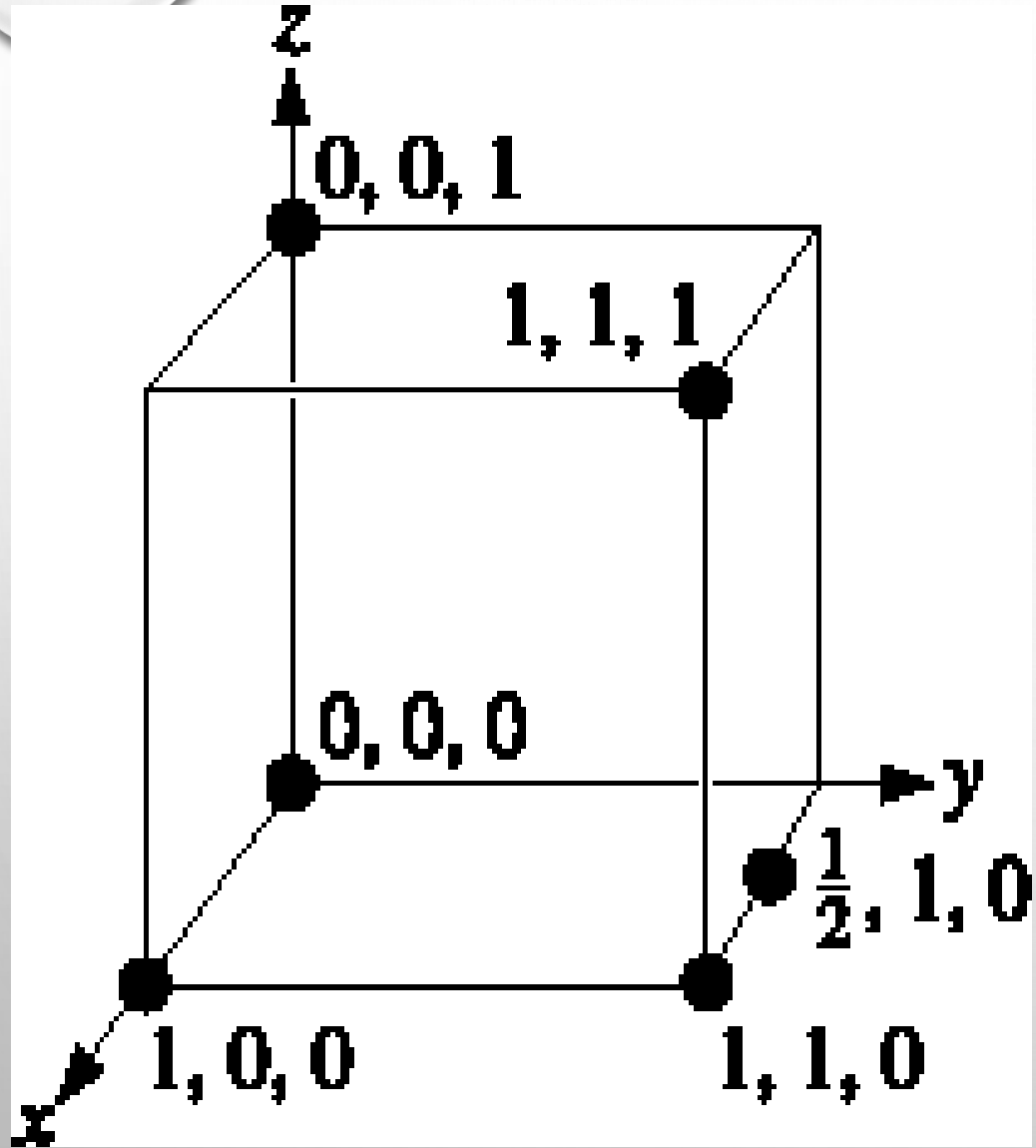

- We start with the coordinates of lattice points in order to define the Miller indices of lattice directions
- Coordinates of selected points in the unit cell. The number refers to the distance from the origin in terms of lattice parameters.

DETERMINING MILLER INDICES OF DIRECTIONS

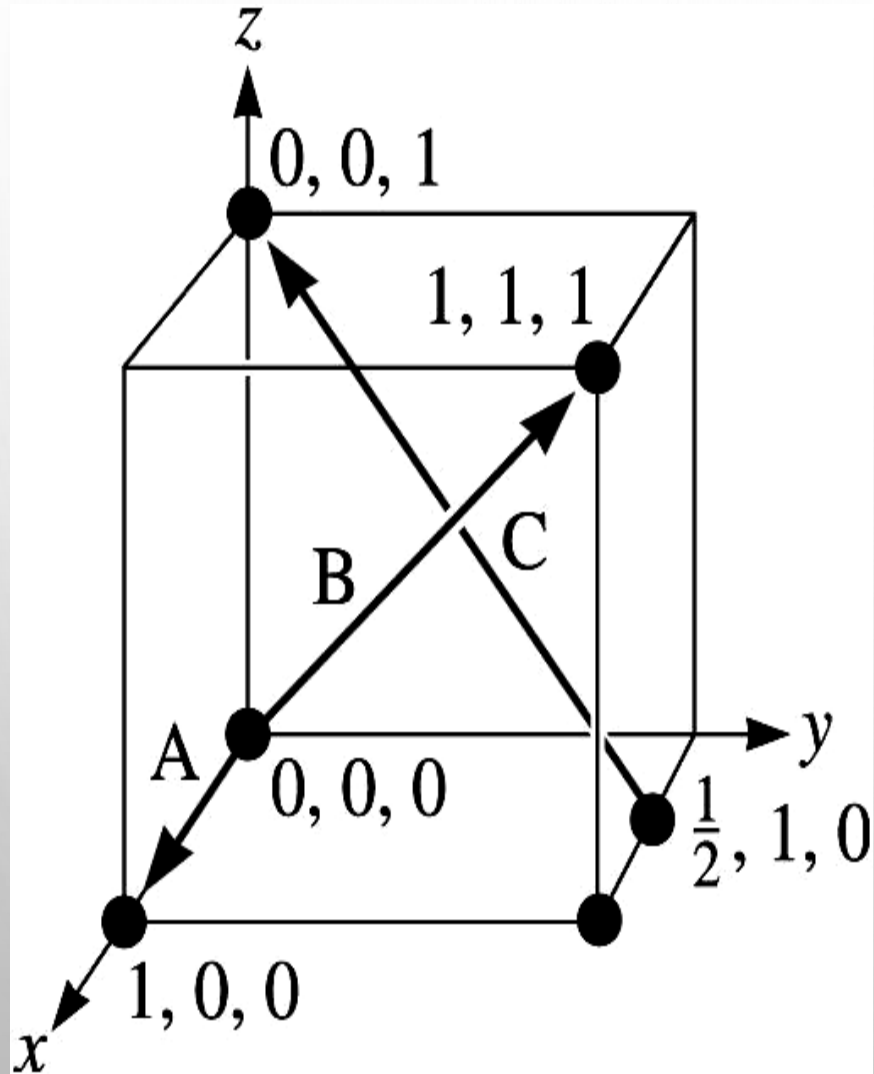

- Determine coordinates of two points that lie in direction of interest, $u_1 v_1 w_1$ and $u_2 v_2 w_2$
- **Calculations are simplified if the second point corresponds with the origin of the coordinate system**
- Subtract coordinates of second point from those of first point: $u' = u_1 - u_2$, $v' = v_1 - v_2$, $w' = w_1 - w_2$
- Clear fractions from the differences to give indices in lowest integer values. Write indices in **[]** brackets. Negative integer values are indicated with a bar over the integer, **$[\bar{u}vw]$** and **$[u\bar{v}w]$** are running in opposite directions.

Direction A

1. Two points are $1, 0, 0$, and $0, 0, 0$
2. $1, 0, 0, - (0, 0, 0) = 1, 0, 0$
3. No fractions to clear or integers to reduce
4. $[100]$

Direction B

1. Two points are $1, 1, 1$ and $0, 0, 0$
2. $1, 1, 1, - (0, 0, 0) = 1, 1, 1$
3. No fractions to clear or integers to reduce
4. $[111]$

Direction C

1. Two points are $0, 0, 1$ and $1/2, 1, 0$
2. $0, 0, 1 - (1/2, 1, 0) = -1/2, -1, 1$
3. $2(-1/2, -1, 1) = -1, -2, 2$
4. $[\bar{1}\bar{2}2]$

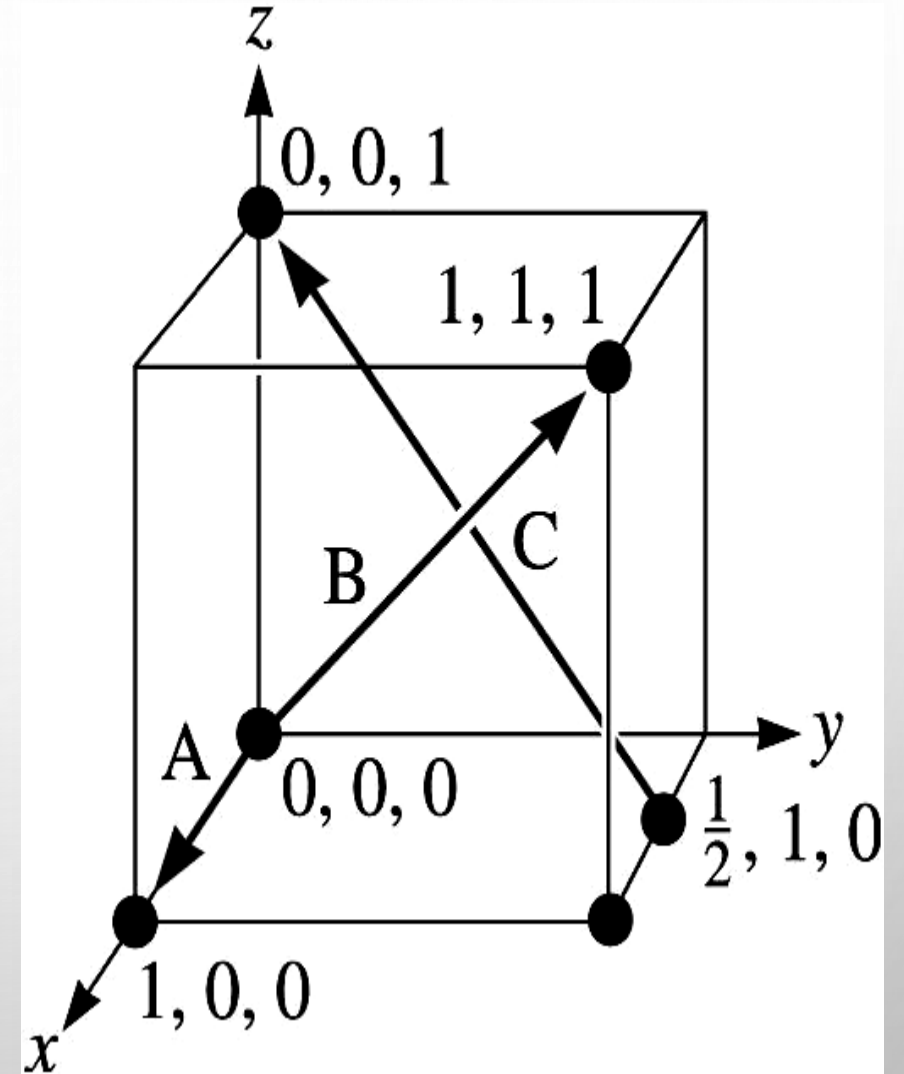

CRISTALLOGRAPHIC PLANES

- Lattice planes are represented by the vector that is normal (perpendicular to them), these are 3D vectors in reciprocal (or dual) space (reciprocal space is nothing fancy - it is just a mathematical convenience !)
- Planes of a form (also called family) –lattice planes that all have the same characteristics, although their “sense” may be different. Denoted by curly $\{$ brackets, they are symmetrically equivalent.

CRISTALLOGRAPHIC PLANES

Indices of Planes

Plane – surface defined by length of its intercepts on the three crystal axes (the three edges of a unit cell).

Intercepts are expressed in terms of the dimensions of unit cell, i.e. unit cell distances along the three axes.

Reciprocals of these intercepts reduced to the smallest three integers = Miller indices.

CRISTALLOGRAPHIC PLANES

Indices of Planes

- Miller indices of a plane, indicated by $h k l$, are given by the reciprocal of the intercepts of the plane on the three axes.
- The plane, which intersects X-axis at 1 (one lattice parameter) and is parallel to Y and Z axes, has Miller indices:

$$h = 1/1 = 1, k = 1/\infty = 0, l = 1/\infty = 0.$$

It is written as $(hkl) = (100)$.

For a plane with intercepts 1, 1, 1:

- Reciprocals = 1, 1, 1
- Miller indices = (111).

CRISTALLOGRAPHIC PLANES

For a plane with intercepts 2, ∞ , 1 (i.e. parallel to OY axis)

- Reciprocals = $\frac{1}{2}$, 0, 1
- Miller indices = (102) when reduced to their lowest integer values.

Planes can also have negative intercepts, e.g.:

- If a plane has a negative intercept, the index will be negative, written with a bar above the number, e.g. ($1\bar{1}0$).
- And for intercepts 1, 1, $-1/2$; $hkl = 1\ 1\ -2$. This is denoted as ($11\bar{2}$).

CRISTALLOGRAPHIC PLANES

- Miller indices of some other planes in the cubic system.

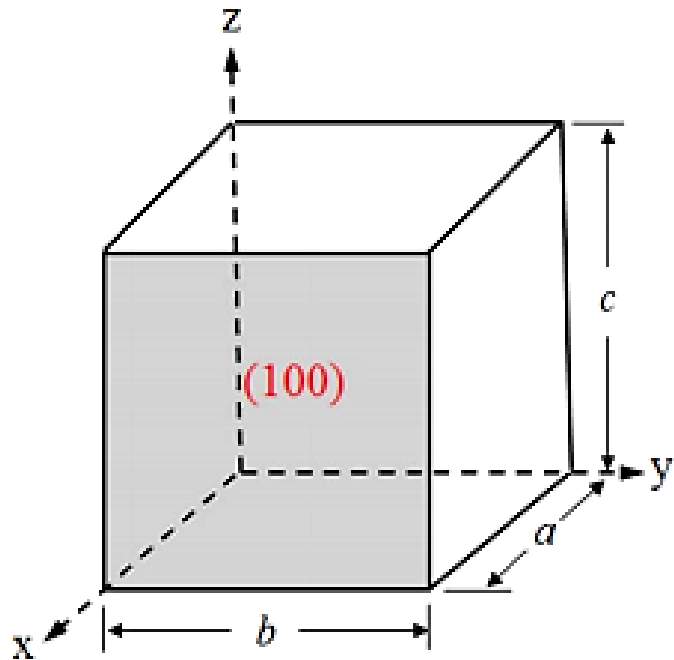

$$\begin{array}{ccc} h & k & l \\ 1 & 1 & 1 \\ \hline 1 & \infty & \infty \end{array} = (100)$$

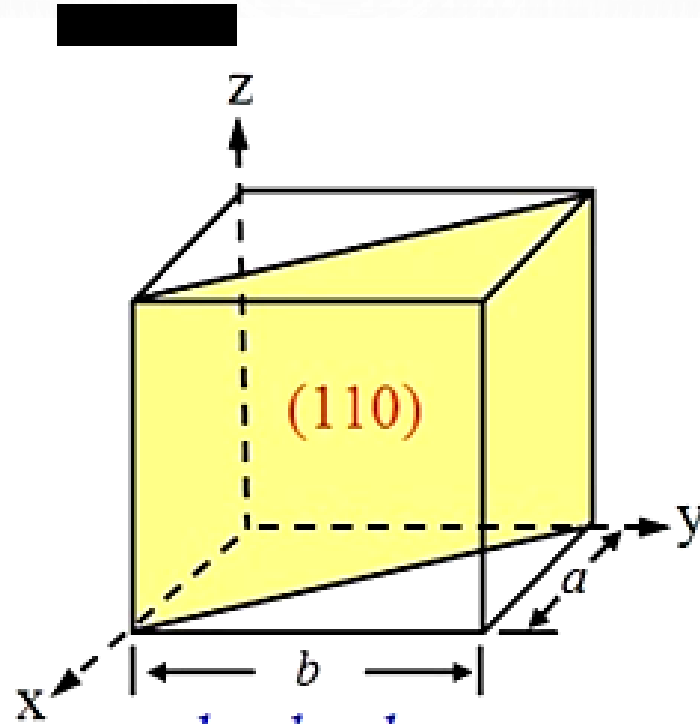

$$\begin{array}{ccc} h & k & l \\ 1 & 1 & 1 \\ \hline 1 & 1 & \infty \end{array} = (110)$$

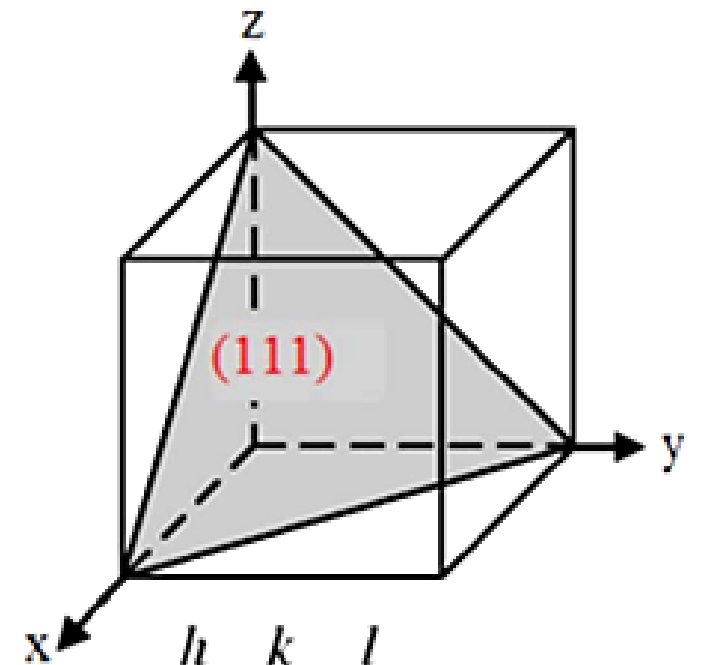

$$\begin{array}{ccc} h & k & l \\ 1 & 1 & 1 \\ \hline 1 & 1 & 1 \end{array} = (111)$$

DETERMINING MILLER INDICES OF PLANES

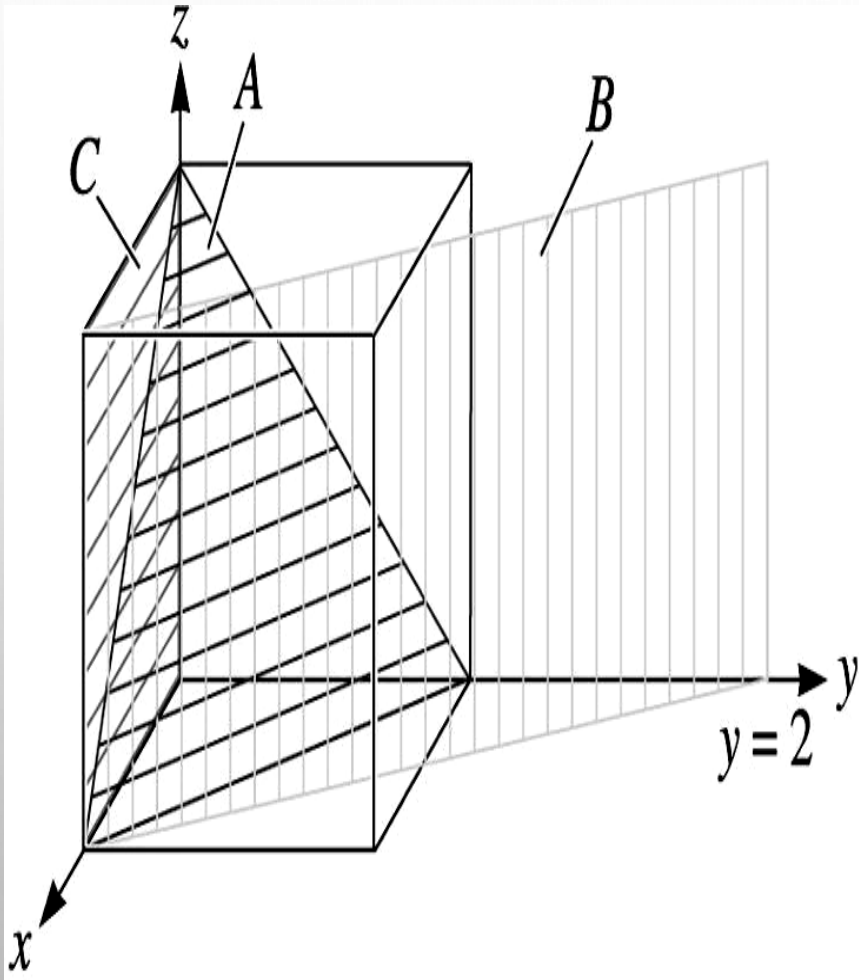

1. Identify the coordinate intercepts of the plane, if plane is parallel to one of the axes, this intercept is taken to be infinite
2. Take the reciprocal of the intercept
3. Clear fractions, but do not reduce to lowest integers
4. Cite in $(h \ k \ l)$ parentheses
5. Negative integer values are indicated with a bar over the integer - $(\bar{h} \ \bar{k} \ \bar{l})$ is the same plane as $(h \ k \ l)$, just its back side

Plane A

1. $x = 1, y = 1, z = 1$
2. $1/x = 1, 1/y = 1, 1/z = 1$
3. No fractions to clear
4. **(111)**

Plane B

1. The plane never intercepts the z axis, so $x = 1, y = 2$, and $z = \infty$. $1/x = 1, 1/y = 1/2, 1/z = 0$
3. Clear fractions: $1/x = 2, 1/y = 1, 1/z = 0$
4. **(210)**

Plane C

1. We shall move the origin, since the plane passes through $0, 0, 0$. Let's move the origin one lattice parameter in the y-direction. Then, $x = \infty, y = -1$, and $z = \infty$
2. $1/x = 0, -1/y = -1, 1/z = 0$
3. No fractions to clear.
4. **(0 $\bar{1}$ 0)**

That seemed a bit arbitrary, we could have moved the origin in the negative (–) y direction as well, then we would have gotten (010), which is just the back side of (0 $\bar{1}$ 0)

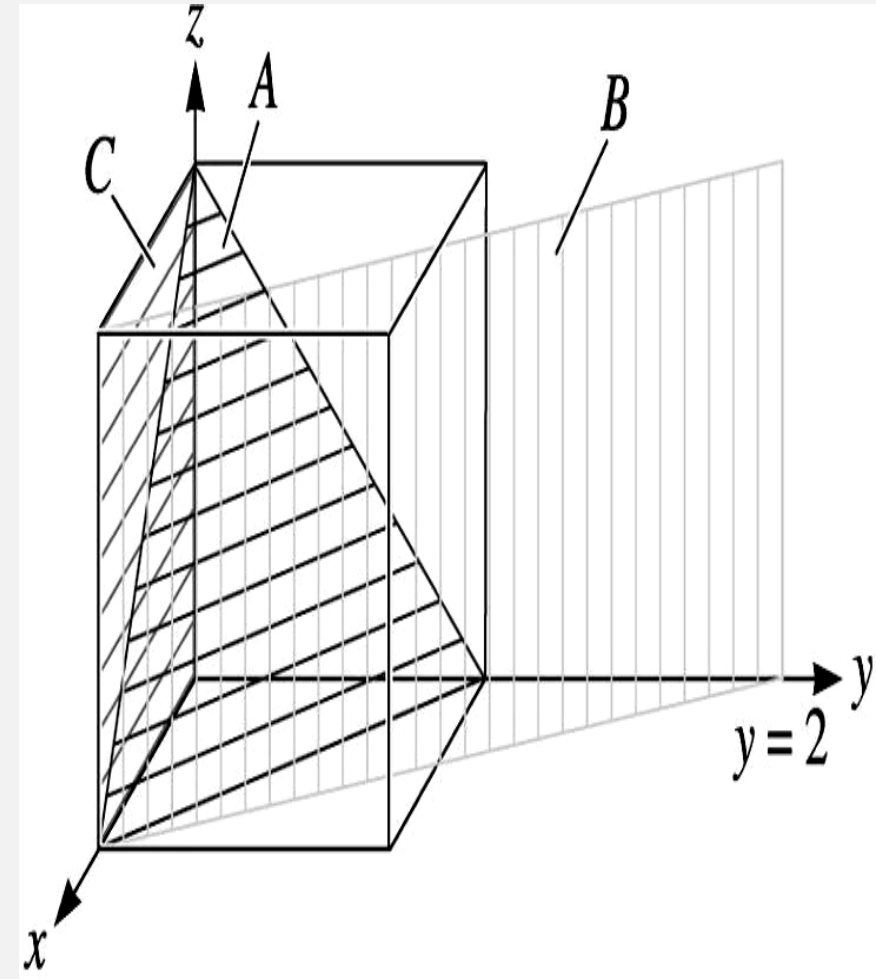

CRISTALLOGRAPHIC PLANES

Family of planes {hkl}

Parenthesis (hkl) around a set of indices signify a single set of parallel planes.

Curly brackets or braces {hkl} signify planes of a form, i.e., a family or a set of equivalent planes.

Thus for the cubic crystal, {110} includes six sets of planes: (110), (101), (011), ($\bar{1}\bar{1}0$), ($10\bar{1}$) and ($01\bar{1}$).

Reversal of the signs of all indices merely denotes another parallel plane. Thus ($\bar{1}\bar{1}0$) is parallel to (110) and (101) to ($\bar{1}0\bar{1}$).

CRISTALLOGRAPHIC PLANES

Family of planes $\{hkl\}$

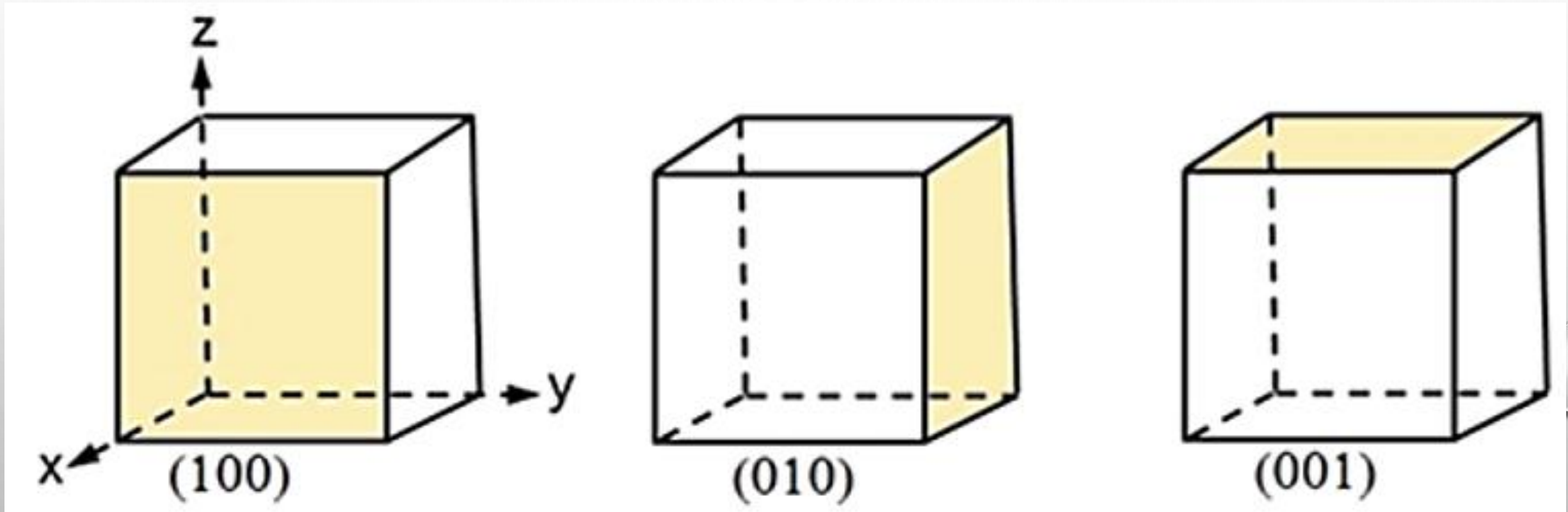

$\{100\}$ Family of planes

Family of planes {hkl}

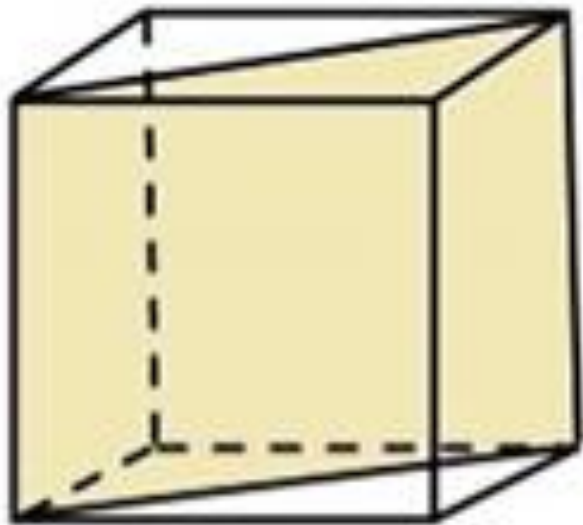

(110)

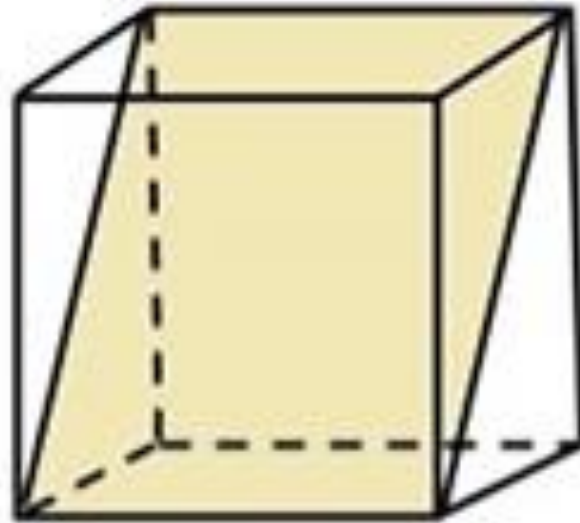

(101)

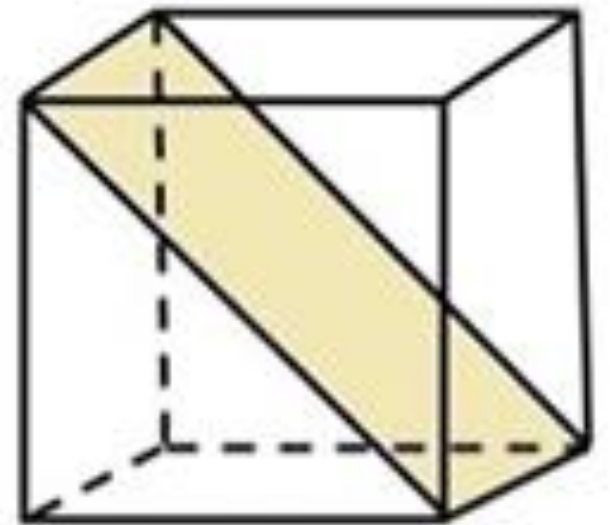

(011)

{110} Family of planes

CRISTALLOGRAPHIC PLANES

Family of planes $\{hkl\}$

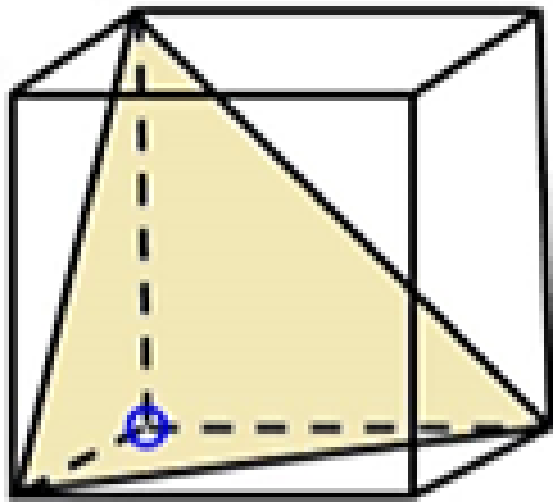

(111)

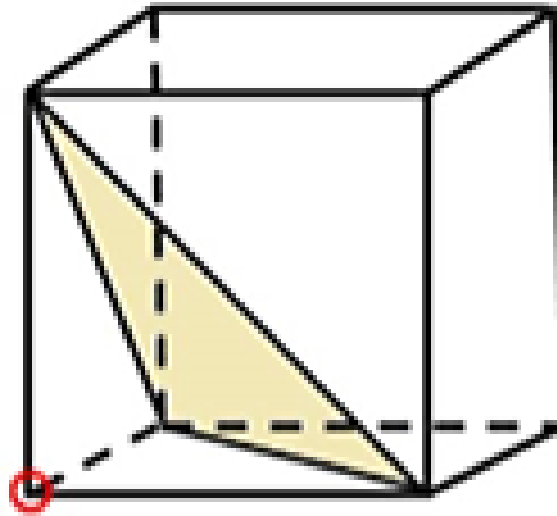

$(\bar{1}11)$

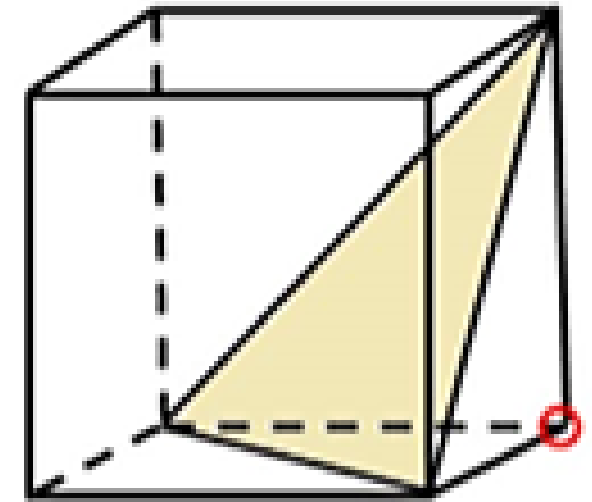

$(1\bar{1}1)$

$\{111\}$ Family of planes

Note the apparent shift of the origin from blue to red circle for the negative indices

RELATIONSHIP BETWEEN DIRECTION AND PLANES

- In the cubic system, planes and directions having the same indices are perpendicular to each other, i.e. if $[uvw]$ is perpendicular to the (hkl) plane.
- Then $h = u$, $k = v$ and $l = w$.
- E.g.: $\{100\}$ planes and $\langle 100 \rangle$ directions are perpendicular to each other.
- If $[uvw]$ direction is parallel to (hkl) plane, that is if $[uvw]$ lies in the plane (hkl) , then $hu + kv + lw = 0$.
- E.g.: $[\bar{1}10]$ lies in the plane (111) since $1.(-1) + 1.1 + 1.0 = 0$

DRAWING DIRECTIONS AND PLANES

Draw (a) the $[\bar{1}\bar{2}1]$ direction and (b) the $(\bar{2}10)$ plane in a cubic unit cell.

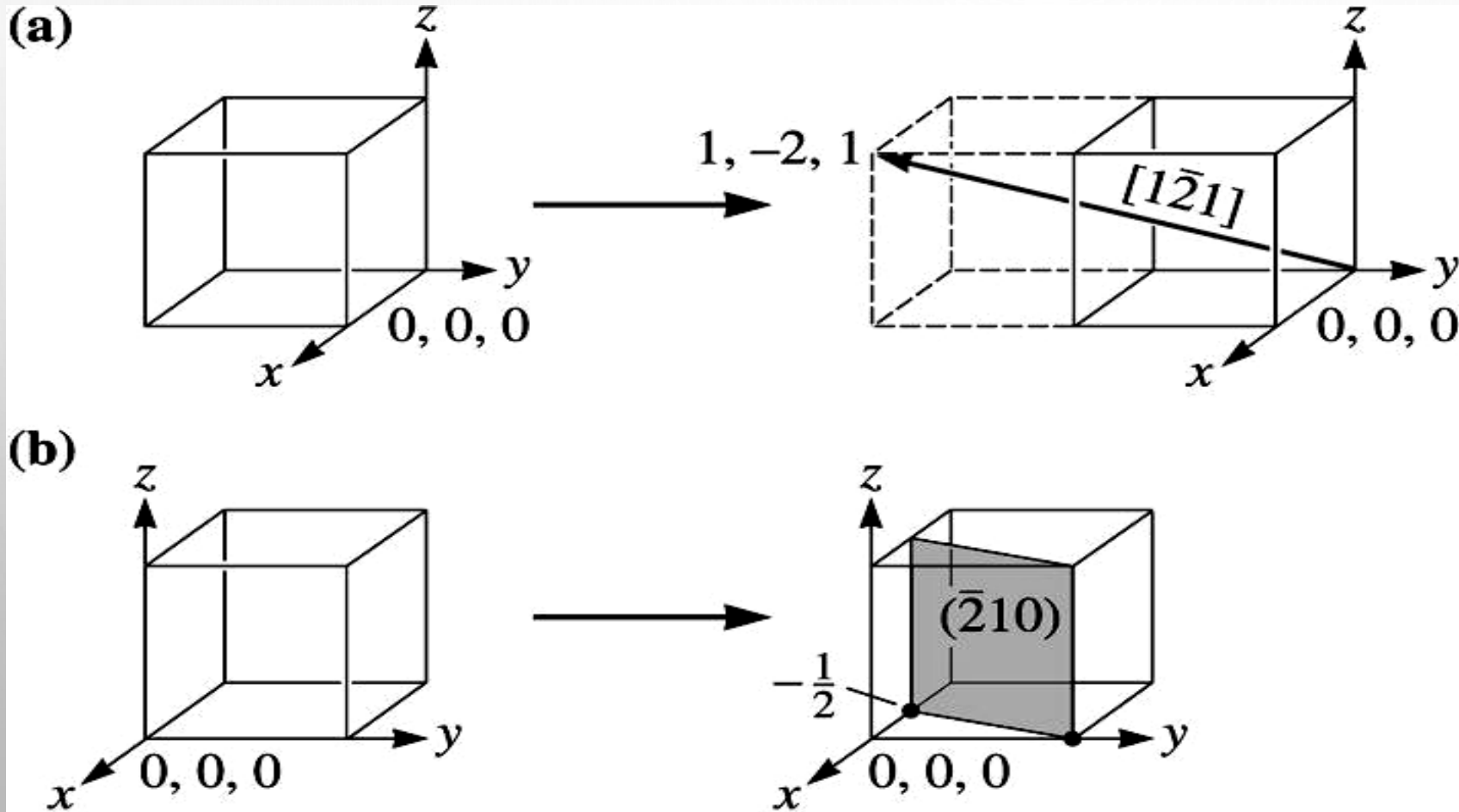

**Construction of a
(a) direction and
(b) plane within a
unit cell**

SOLUTION

a. Because we know that we will need to move in the negative y -direction, let's locate the origin at $0, +1, 0$. The "tail" of the direction will be located at this new origin. A second point on the direction can be determined by moving $+1$ in the x -direction, 2 in the negative y -direction, and $+1$ in the z direction.

a. To draw in the $[\bar{2}10]$ plane, first take reciprocals of the indices to obtain the intercepts, that is:

$$x = 1/\bar{2} = -1/2$$

$$y = 1/1 = 1 \quad z = 1/0 = \infty$$

Since the x -intercept is in a negative direction, and we wish to draw the plane within the unit cell, let's move the origin $+1$ in the x -direction to $1, 0, 0$. Then we can locate the x -intercept at $1/2$ and the y -intercept at $+1$. The plane will be parallel to the z -axis.

DRAWING DIRECTIONS AND PLANES

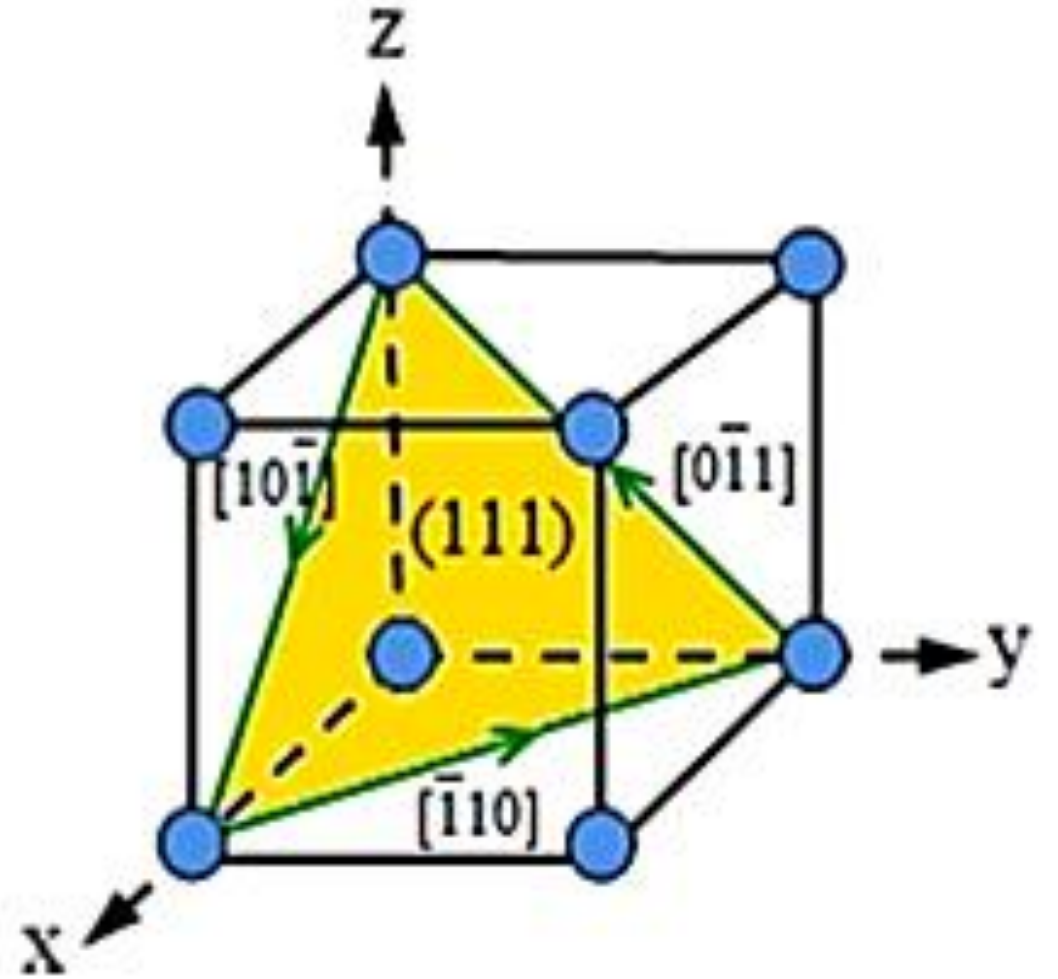
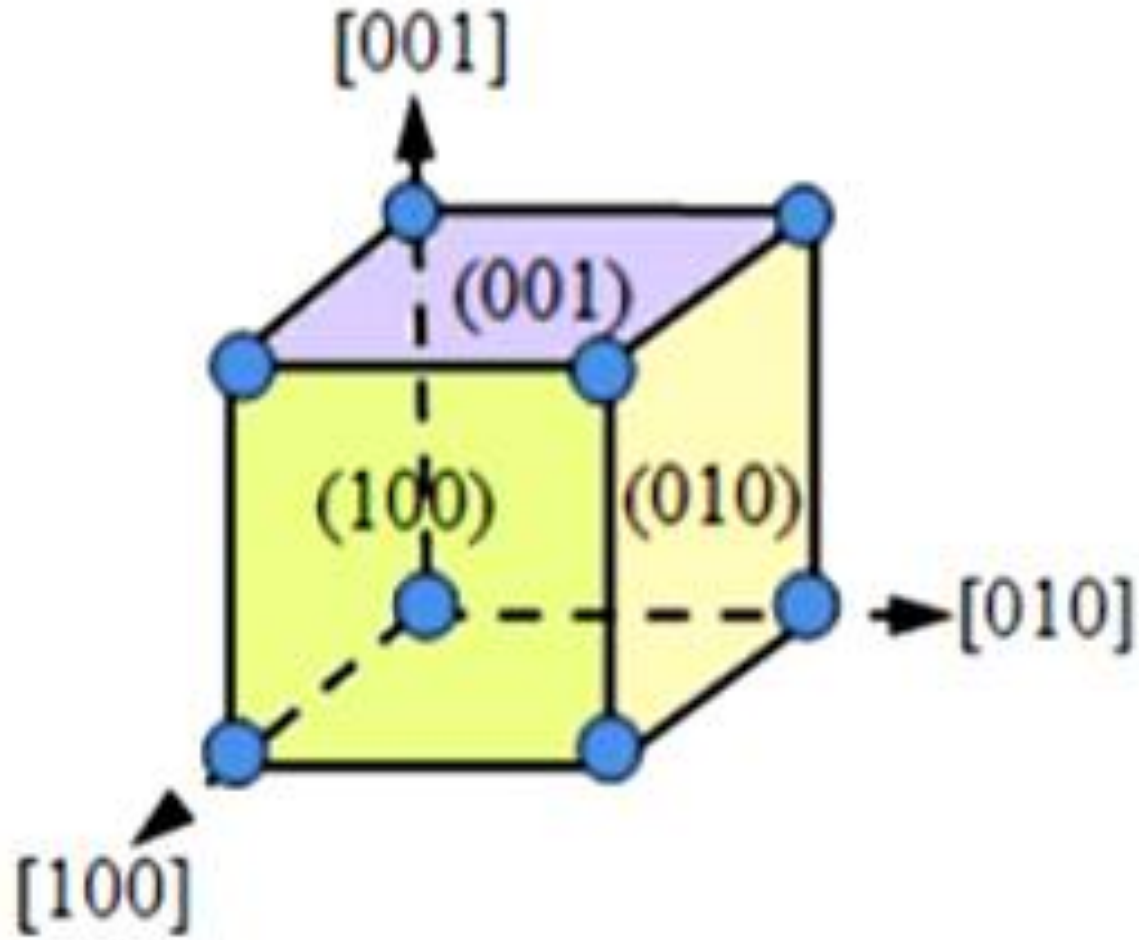

PLANES IN THE HEXAGONAL SYSTEM

- In the cubic system, all the faces of the cube are equivalent, that is, they have similar indices.
- A problem arises for crystals having hexagonal symmetry in that some crystallographic equivalent directions will not have the same set of indices
- The six prism faces, for example, have indices (100) , (010) , $(\bar{1}10)$, $(\bar{1}00)$, $(0\bar{1}0)$ and $(1\bar{1}0)$, which are not the same or equivalent.

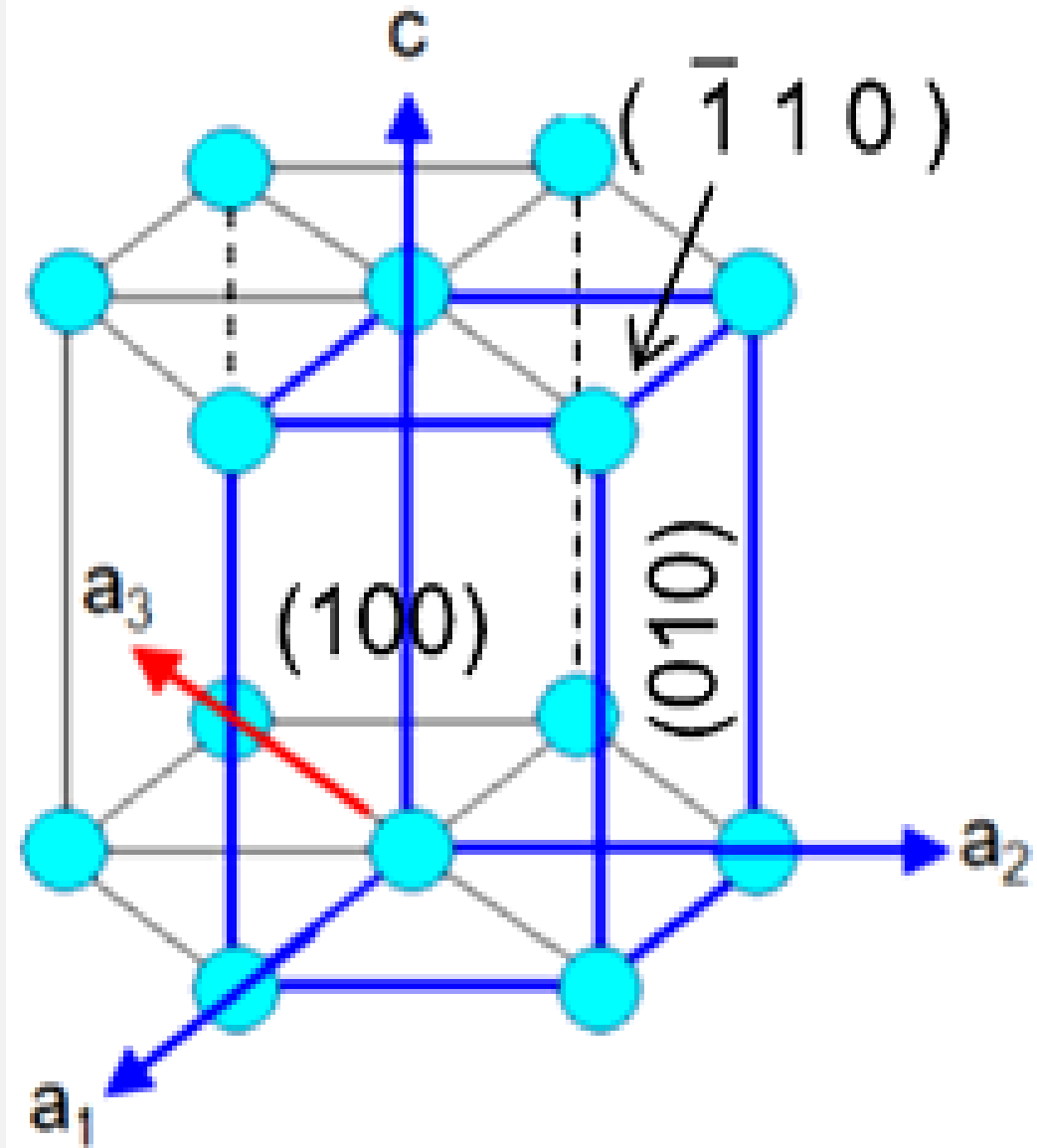

PLANES IN THE HEXAGONAL SYSTEM

- This is circumvented by utilizing a four-axis, or **Miller–Bravais**, coordinate system as shown in the figure. The three a_1 , a_2 , a_3 axes are all contained within a single plane (called the basal plane) and are at 120° angles to one another.
- The z axis (c) is perpendicular to this basal plane.

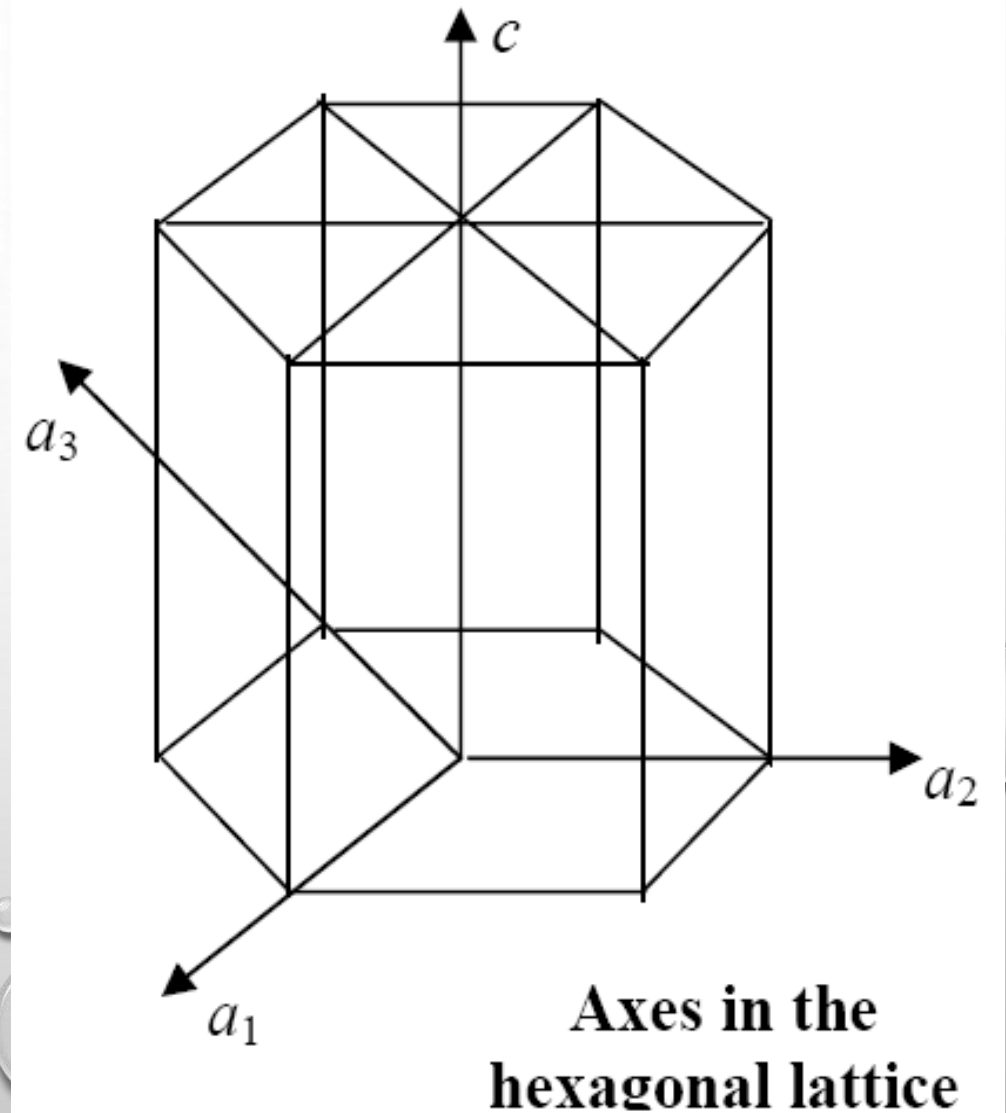

PLANES IN THE HEXAGONAL SYSTEM

- Directional indices, which are obtained as described earlier, will be denoted by four indices, as $[hkil]$; by convention, the first three indices pertain to projections along the respective a_1 , a_2 , and a_3 axes in the basal plane.

Treatment is the same as *Miller indices*.

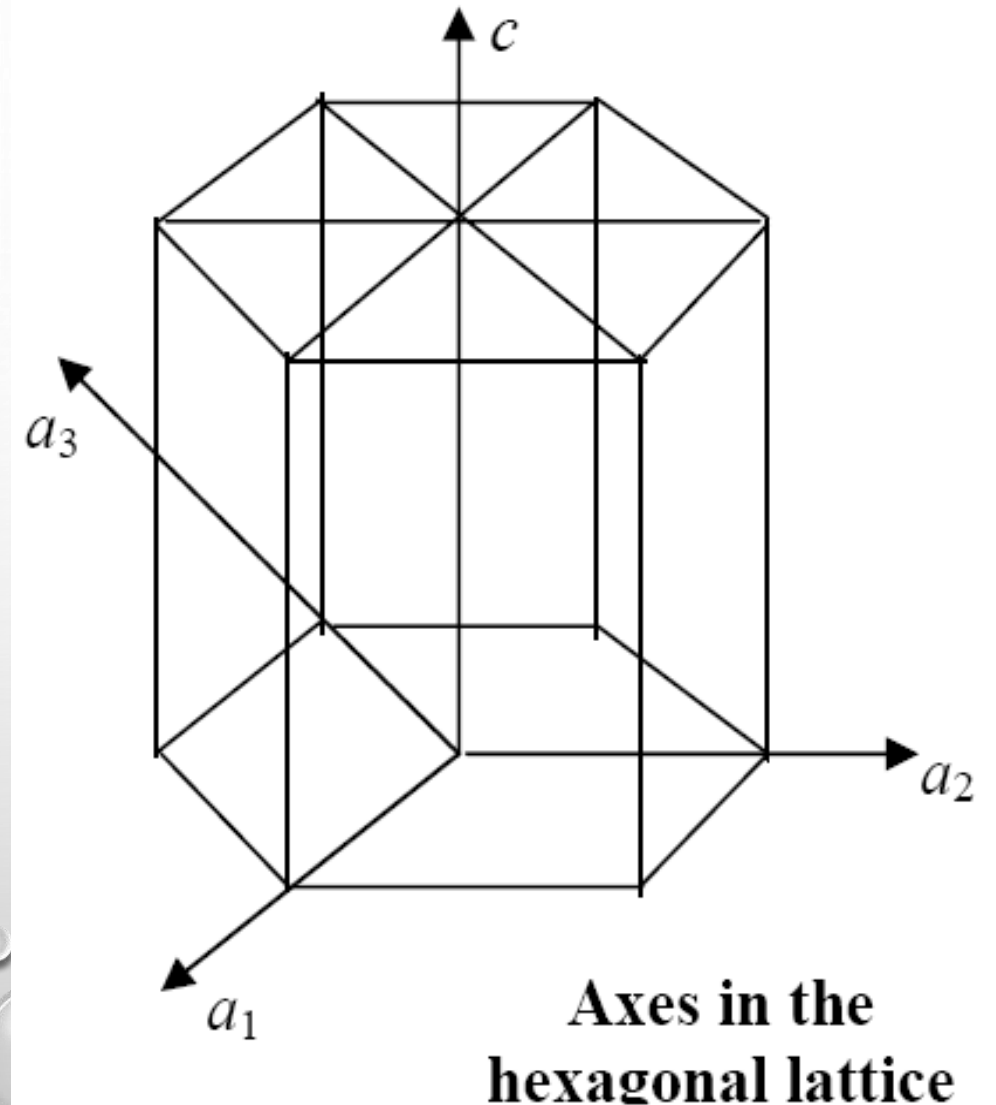

PLANES IN THE HEXAGONAL SYSTEM

- The fourth axis (a_3) is added which is opposite to the vector sum of a_1 and a_2 .
- A corresponding fourth index is thus used along with hkl .
- Therefore the indices of a plane is given by **(hki)** ,

$$\text{where } i = -(h + k)$$

Sometime i is replaced with a dot and written as **$(h k \cdot l)$**

PLANES IN THE HEXAGONAL SYSTEM

The indices of six faces now become $(10\bar{1}0)$, $(01\bar{1}0)$, $(\bar{1}100)$, $(\bar{1}010)$, $(0\bar{1}10)$, $(1\bar{1}00)$ which are now equivalent and belong to the $\{10\bar{1}0\}$ family of planes.

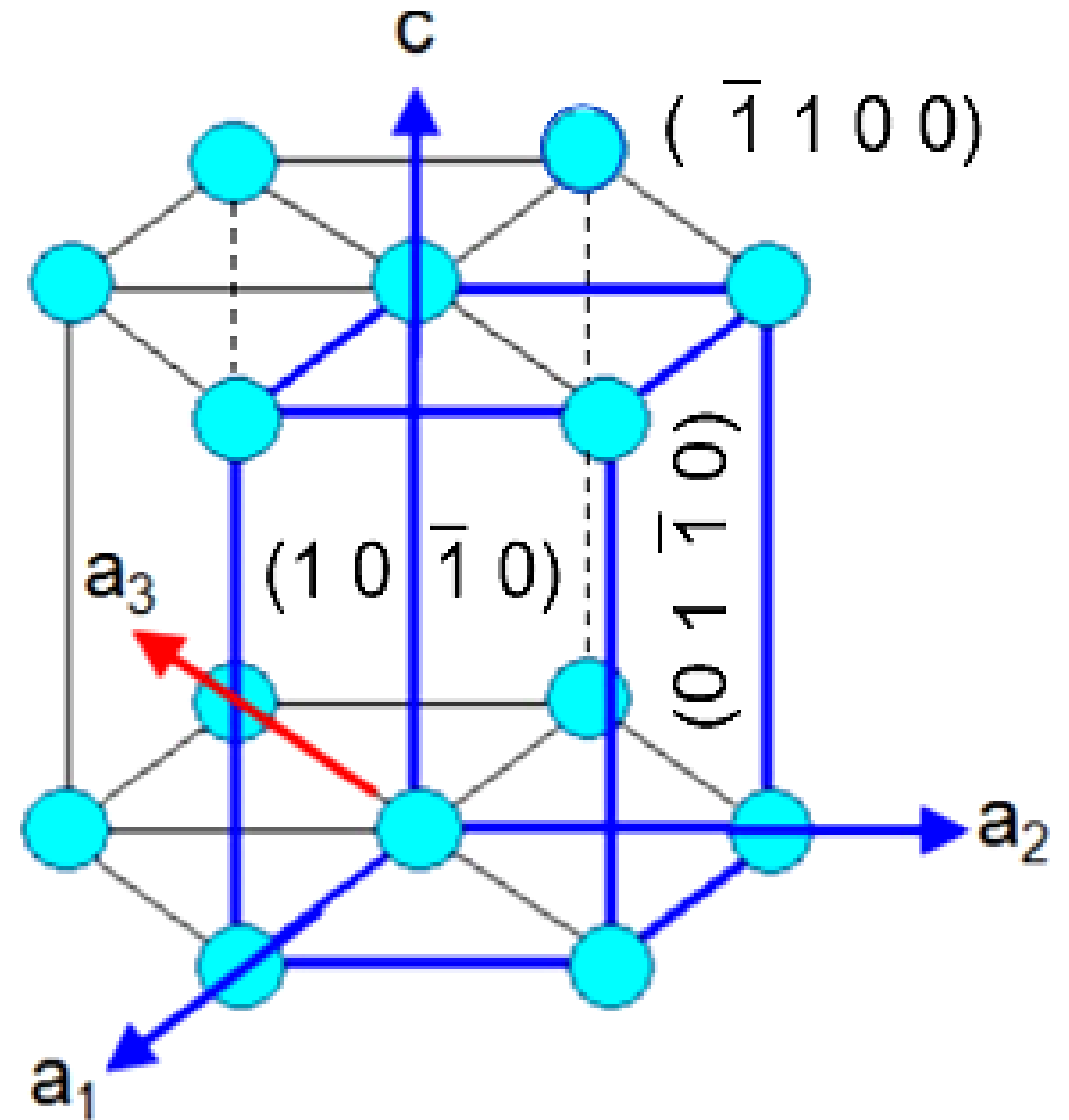

PLANES IN THE HEXAGONAL SYSTEM

Note:

The first three indices are not independent but must satisfy:

$$h + k + i = 0$$

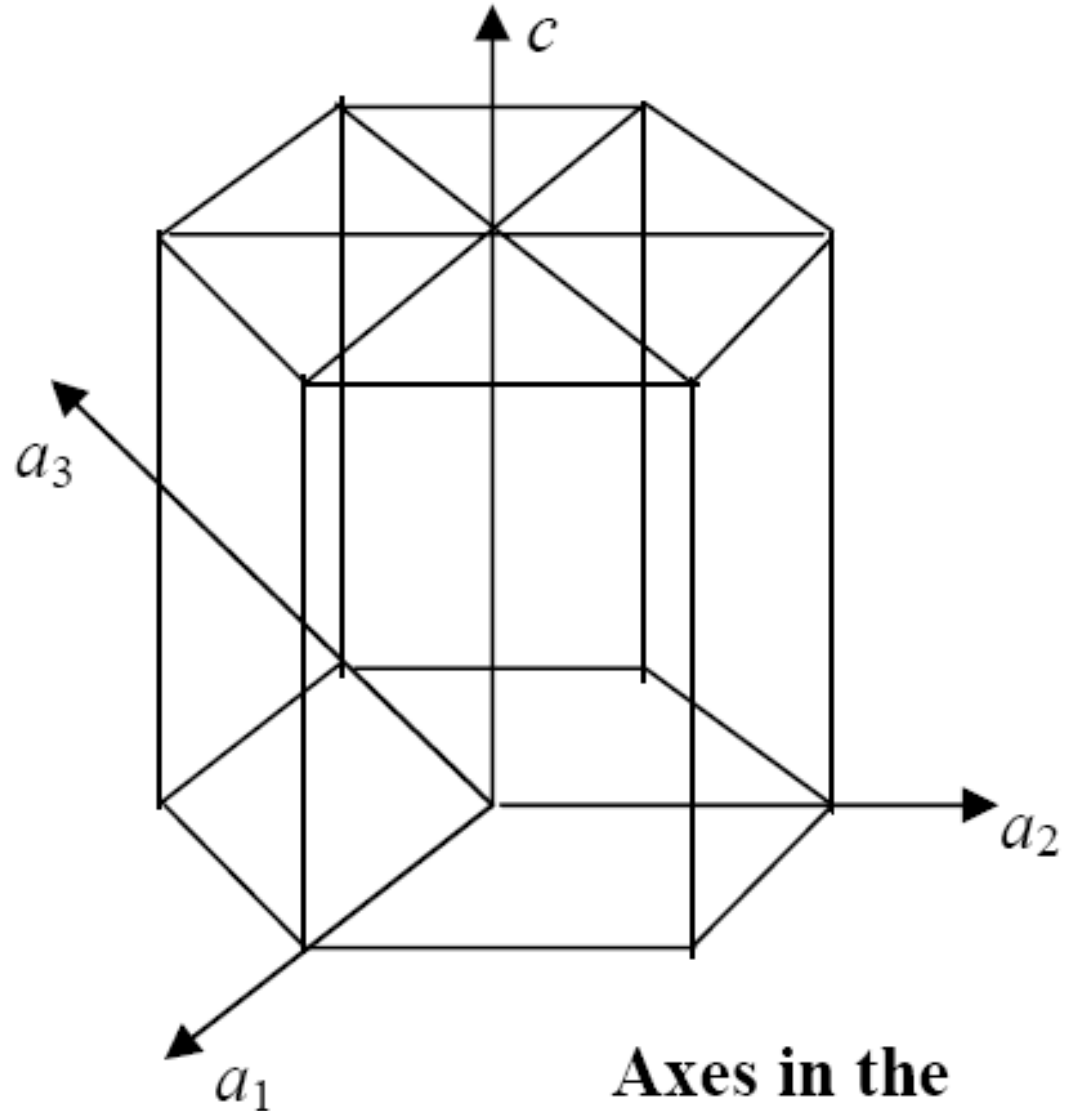

**Axes in the
hexagonal lattice**

DETERMINING MILLER-BRAVAIS INDICES FOR PLANES IN THE HEXAGONAL SYSTEM

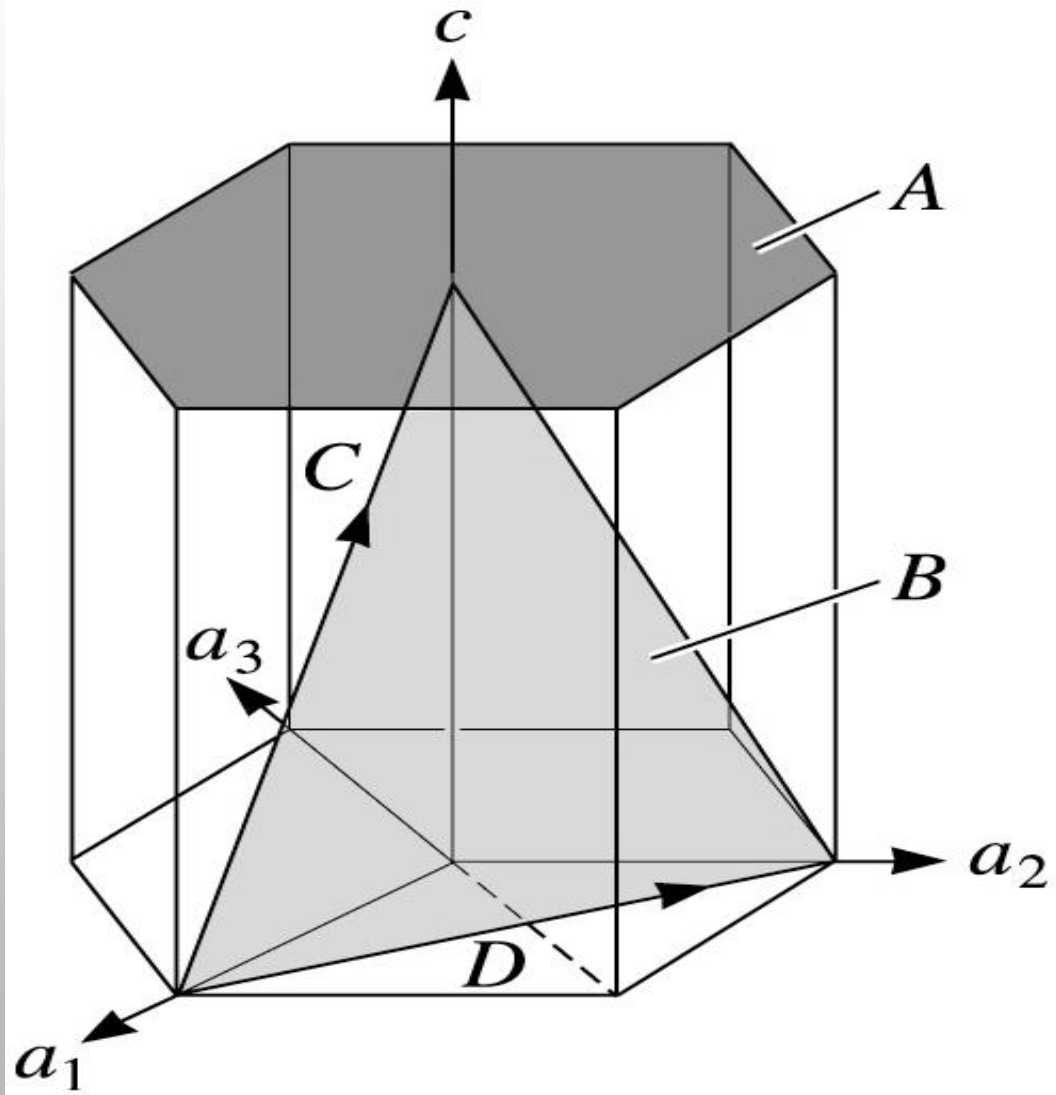

- Miller- Bravais indices are obtained for crystallographic planes, directions, and points in hexagonal unit cells by using a **four-axis coordinate system**.
- For planes $(hkil)$, the index $i = -(h+k)$,
i.e. $h+k = -i$

MILLER- BRAVAIS INDICES FOR PLANES ARE STRAIGHTFORWARD, JUST AS WE OBTAINED THE INTERSECTS FOR 3 AXES, WE HAVE TO OBTAIN THEM NOW FOR 4 AXES

Plane A

1. $a_1 = a_2 = a_3 = 0, c = 1$
2. $1/ a_1 = 1/ a_2 = 1/ a_3 = \infty = 0, 1/ c = 1$
3. No fractions to clear
4. (0001)

Plane B

1. $a_1 = 1, a_2 = 1, a_3 = - 1/2, c = 1$
2. $1/ a_1 = 1, 1/ a_2 = 1, 1/ a_3 = - 2, 1/ c = 1$
3. No fractions to clear
4. $(11\bar{2}1)$

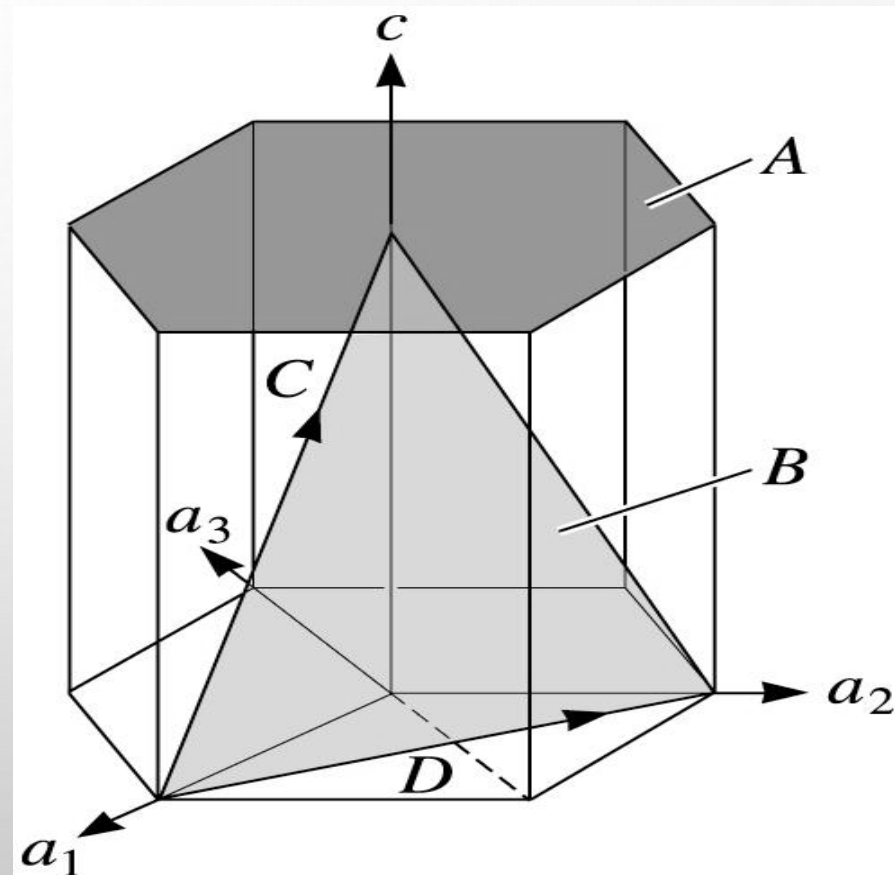

DIRECTIONS IN THE HEXAGONAL SYSTEM

CONVERSION FROM THE THREE-INDEX SYSTEM TO THE FOUR-INDEX SYSTEM,

- Like planes, directions in the hexagonal system are also written in terms of four indices as $[uvtw]$.
- If $[u'v'w']$ are indices in three axes, then it can be converted to four-axis indices $[uvtw]$ using the following relations:

$$u = \frac{1}{3}(2u' - v')$$

$$v = \frac{1}{3}(2v' - u')$$

$$t = -(u + v)$$

$$w = w'$$

E.g.: $[100] = [2\bar{1}\bar{1}0]$ and $[210] = [10\bar{1}0]$.

DETERMINING MILLER-BRAVAIS INDICES FOR PLANES AND DIRECTIONS IN THE HEXAGONAL SYSTEM

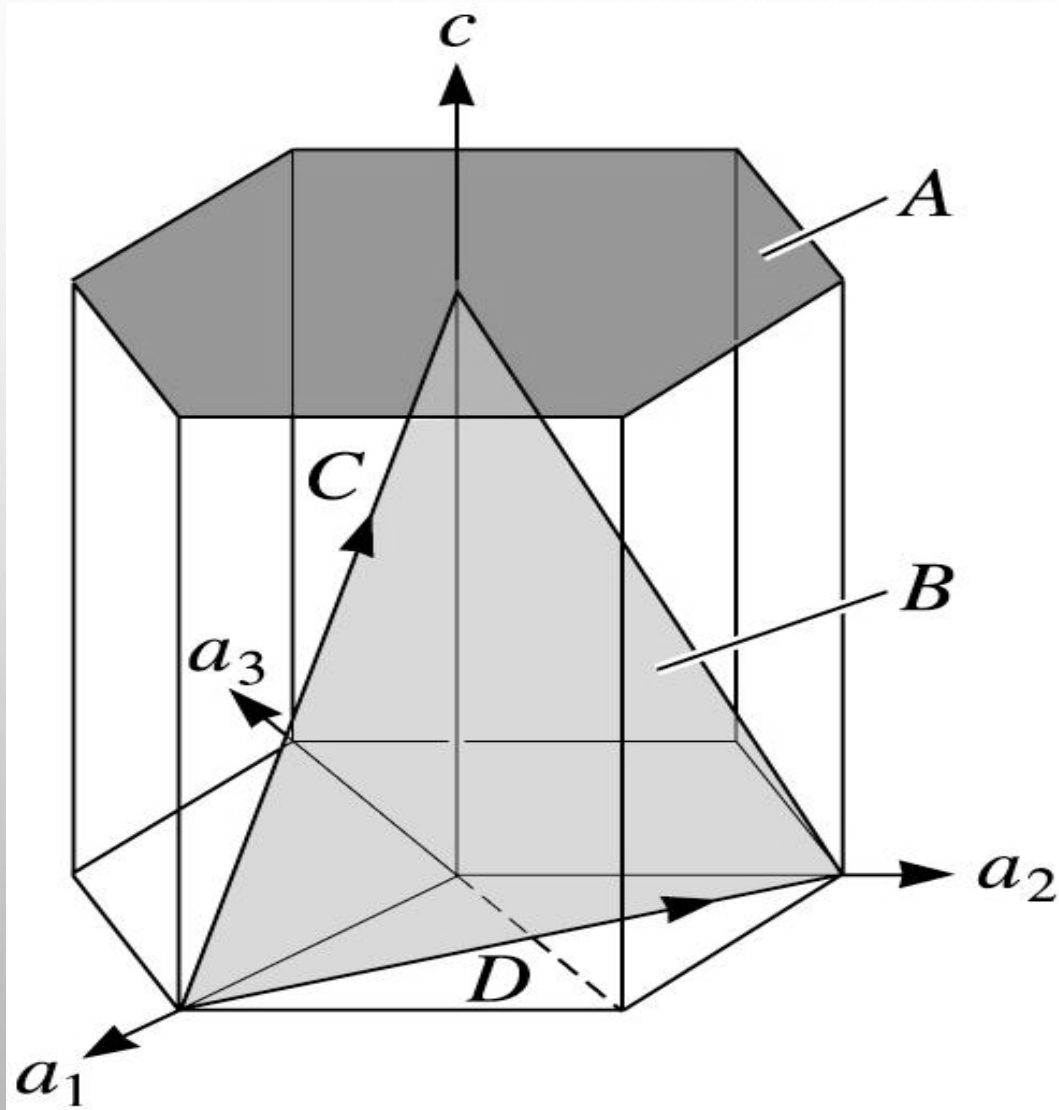

- Miller- Bravais indices are obtained for crystallographic planes, directions, and points in hexagonal unit cells by using a **four-axis coordinate system**.
- For directions $[uv tw]$, we have also $t = (u+v)$, **i.e. $u+v = -t$**

DETERMINING DIRECTIONS IN THE HEXAGONAL SYSTEM IS A BIT MORE CHALLENGING. IT IS EASIER TO CALCULATE WITH 3 INDICES AND THEN SIMPLY MAKE UP THE FORTH

Direction *c*

1. Two points are $0, 0, 1$ and $1, 0, 0$.
2. $0, 0, 1, - (1, 0, 0) = -1, 0, 1$
3. No fractions to clear or integers to reduce.
4. $[1\bar{0}1]$ or $[2\bar{1}13]$

Direction *D*

1. Two points are $0, 1, 0$ and $1, 0, 0$.
2. $0, 1, 0, - (1, 0, 0) = -1, 1, 0$
3. No fractions to clear or integers to reduce.
4. $[\bar{1}10]$ or $[\bar{1}100]$ (extension to 4 indices looks easy, but is not !)

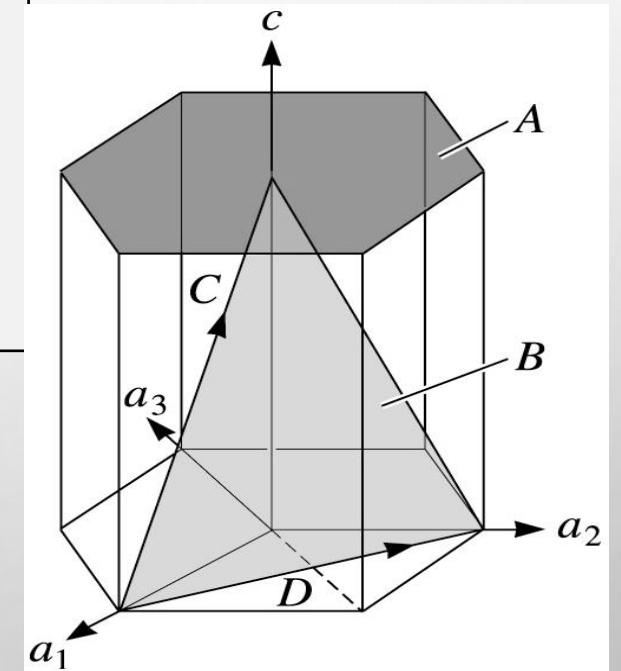

DETERMINING DIRECTIONS AND PLANES IN THE HEXAGONAL SYSTEM

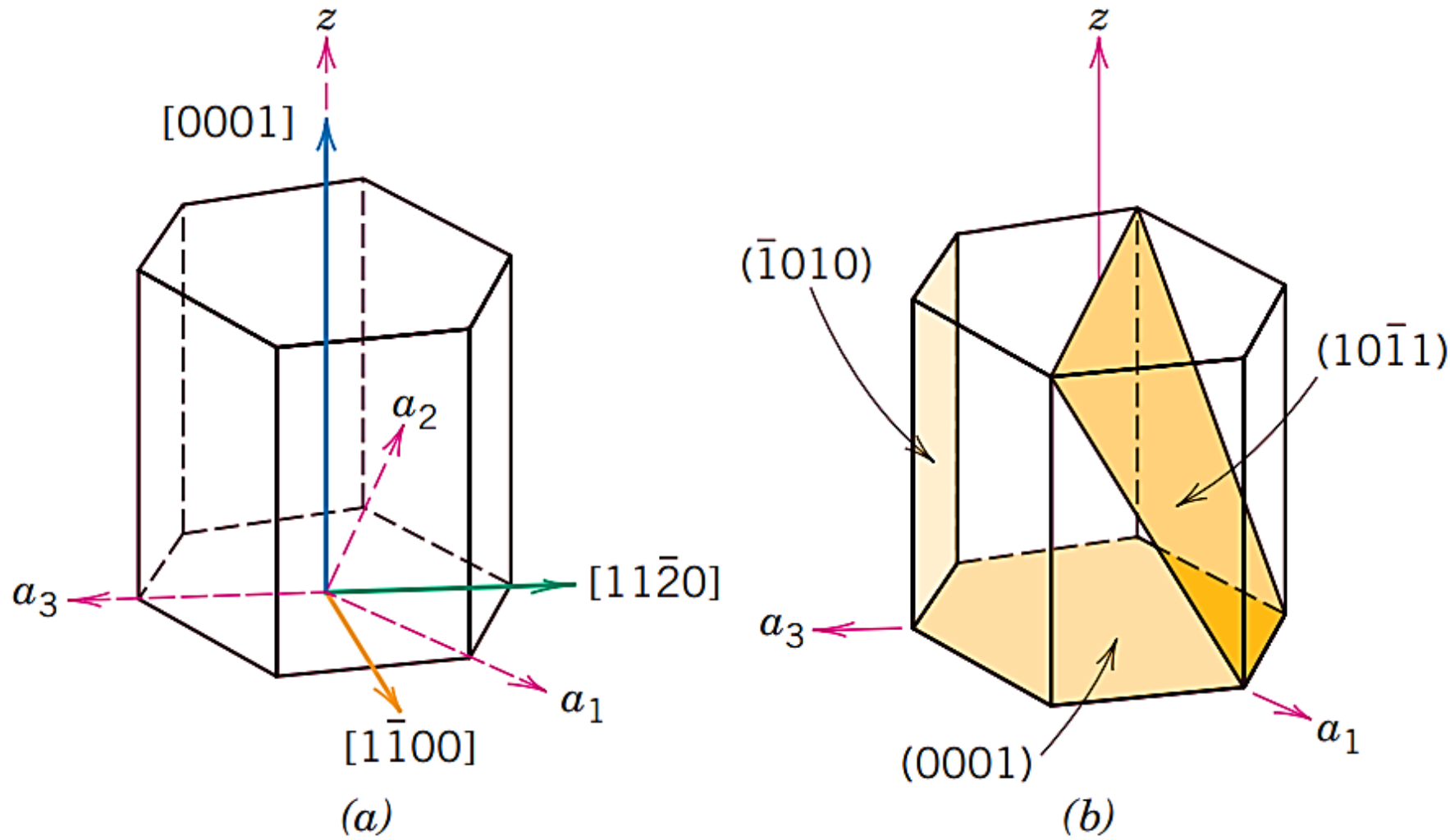

For the hexagonal crystal system, (a) the $[0001]$, $[1\bar{1}00]$, and $[11\bar{2}0]$ directions, and (b) the (0001) , $(10\bar{1}1)$, and $(\bar{1}010)$ planes.

LINEAR AND PLANAR DENSITIES

Linear Density

Linear density (LD) is defined as the number of atoms per unit length whose centers lie on the direction vector for a specific crystallographic direction; that is.

$$LD = \frac{\textit{Number of atoms centered on direction vector}}{\textit{Length of Direction Vector}}$$

The units of linear density are reciprocal length (e.g., nm⁻¹ , m⁻¹)

LINEAR AND PLANAR DENSITIES

Linear Density - Example

Determine the linear density of the [110] direction for the FCC crystal structure.

An FCC unit cell (reduced sphere) and the [110] direction therein are shown in the figure.

- Each of the X and Z corner atoms is also shared with one other adjacent unit cell along this [110] direction (i.e., one-half of each of these atoms belongs to the unit cell being considered), while atom Y lies entirely within the unit cell.
- Thus, there is an equivalence of two atoms along the [110] direction vector in the unit cell. Now, the direction vector length is equal to $4R$ thus the [110] linear density for FCC is:

$$LD_{110} = \frac{2 \text{ atoms}}{4R} = \frac{1}{2R}$$

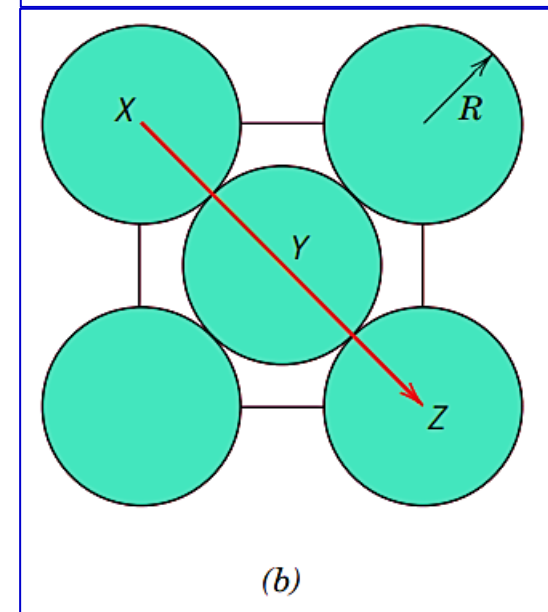
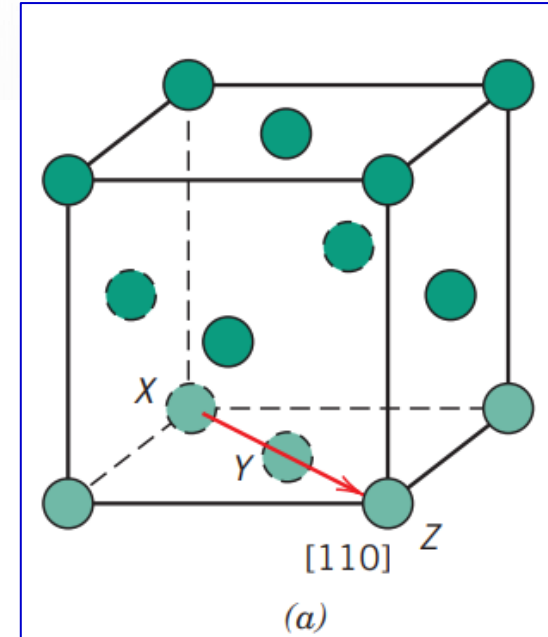

LINEAR AND PLANAR DENSITIES

Planar Density

Planar density (PD) is taken as the number of atoms per unit area that are centered on a particular crystallographic plane. That is;

$$PD = \frac{\textit{Number of atoms centered on a plane}}{\textit{Area of Plane}}$$

The units for planar density are reciprocal area (e.g., nm⁻² , m⁻²)

LINEAR AND PLANAR DENSITIES

Planar Density - Example

Consider the section of a **(110) plane** within an FCC unit cell as represented in Figures (a) and (b).

Practice Exercise

Show that the planar density of the (110) plane within the FCC unit cell =

$$PD_{110} = \frac{2 \text{ atoms}}{8R^2\sqrt{2}} = \frac{1}{4R^2\sqrt{2}}$$

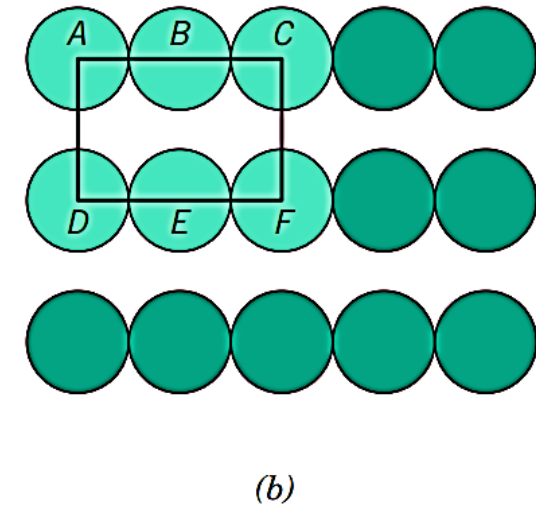
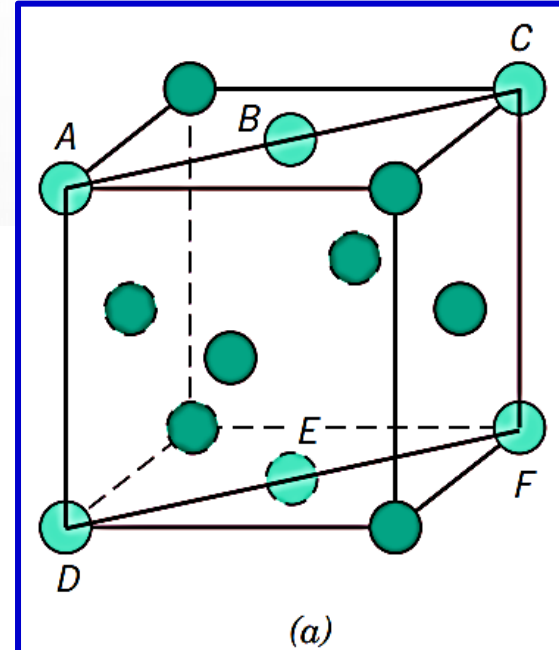

LINEAR AND PLANAR DENSITIES

Planar Density - Example

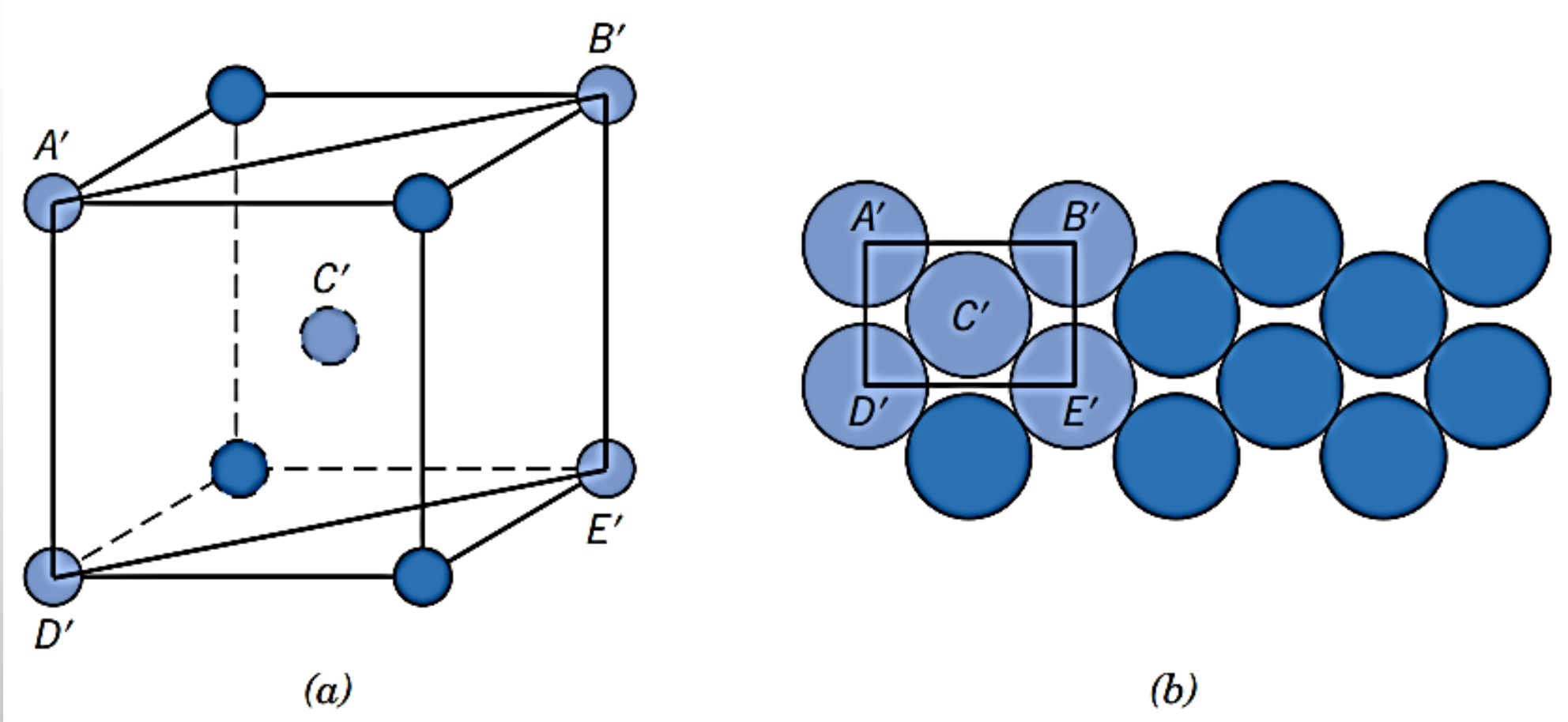

Reduced-sphere BCC unit cell with the (110) plane. (b) Atomic packing of a BCC (110) plane. Corresponding atom positions from (a) are indicated.

INTERPLANAR SPACING

The spacing between planes in a crystal is known as the *interplaner spacing* and is denoted as d_{hkl} .

In the cubic system, spacing between the (hkl) planes is given as:

$$\frac{1}{d_{hkl}^2} = \frac{1}{a^2}h^2 + \frac{1}{a^2}k^2 + \frac{1}{a^2}l^2 = \frac{1}{a^2}(h^2 + k^2 + l^2)$$

Therefore:

$$d_{hkl} = \frac{a}{\sqrt{h^2 + k^2 + l^2}}$$

INTERPLANAR SPACING

In the Tetragonal system, $\frac{1}{d_{hkl}^2} = \frac{1}{a^2} (h^2 + k^2) + \frac{1}{c^2} l^2$

In hexagonal system, $\frac{1}{d_{hkl}^2} = \frac{1}{a^2} h^2 + \frac{1}{a^2} k^2 + \frac{1}{c^2} l^2$

In Orthorhombic system, $\frac{1}{d_{hkl}^2} = \frac{1}{a^2} h^2 + \frac{1}{b^2} k^2 + \frac{1}{c^2} l^2$

or alternatively, $\frac{1}{d_{hkl}^2} = \frac{1}{3a^2} (h^2 + hk + k^2) + \frac{1}{c^2} l^2$

INTERPLANAR SPACING

Example

For BCC iron, compute the interplanar spacing for the (220) set of planes. The lattice parameter for Fe is 0.2866 nm.

Solution

The value of the interplanar spacing d_{hkl} is determined using Equation with $a = 0.2866$ nm, and $h = 2$, $k = 2$, and $l = 0$, because we are considering the (220) planes. Therefore,

$$\begin{aligned}d_{hkl} &= \frac{a}{\sqrt{h^2 + k^2 + l^2}} \\ &= \frac{0.2866 \text{ nm}}{\sqrt{(2)^2 + (2)^2 + (0)^2}} = 0.1013 \text{ nm}\end{aligned}$$

SUMMARY CRYSTALS

- Atoms typically assemble into crystals some materials e.g. glass are amorphous
- We can predict the density of a material, provided we know the atomic weight, atomic radius, and crystal geometry (e.g., FCC, BCC, HCP).
- Material properties generally vary with single crystal orientation (i.e., they are anisotropic), but properties are frequently quite non-directional (i.e., they are isotropic) in polycrystals with randomly oriented grains as e.g. in steel and other engineering materials



END OF LECTURE 4