

CEE 2219 – STATICS & INTRODUCTION TO MECHANICS OF MATERIALS

1

JQL
05/03/2021

Lecture A2

- ❖ FORCE VECTORS
- ✓ EQUILIBRIUM OF A PARTICLE (2D)
- ✓ INTRODUCTION TO FORCES IN SPACE (3D)

LECTURE OBJECTIVES

2

- ❖ To show how to add forces and resolve them into rectangular components using the Parallelogram Law
- ❖ To understand Scalar and Cartesian notation
- ❖ To express force and position as Cartesian vectors

FORCE VECTORS

Addition of a System of Coplanar Forces

- ▶ *In many problems it will be found desirable to resolve a force into two components which are perpendicular to each other*
- ▶ *When a force is resolved into two components along the x and y axes, the components are then called rectangular components*
- ▶ *The parallelogram drawn to obtain the two components is a rectangle, and F_x and F_y are called rectangular components*

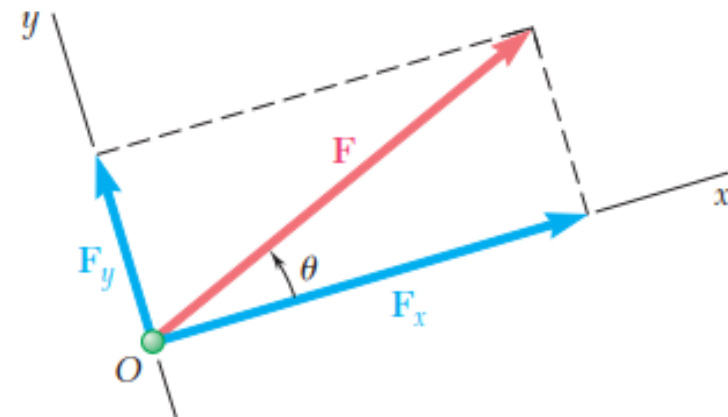
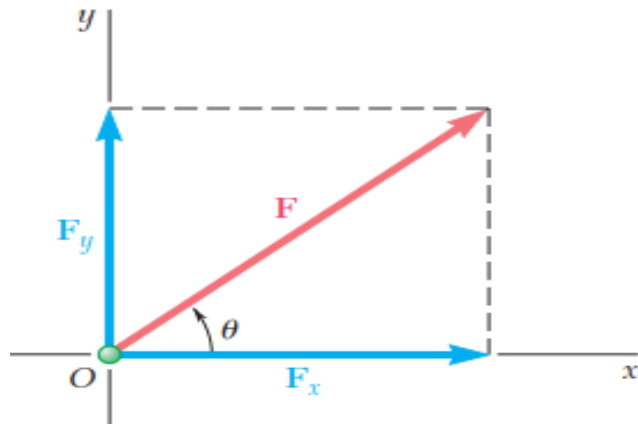

FORCE VECTORS

Addition of a System of Coplanar Forces

- ▶ *In this way it becomes easier to obtain resultants for more than two forces by getting the components of each force along specified axes and add them algebraically instead of using successive application of the parallelogram law*
- ▶ *Note that the axes will be horizontal and vertical or directed at any inclination as long as they remain perpendicular to one another*
- ▶ *By parallelogram law it is required that:*

$$F = F_x + F_y$$

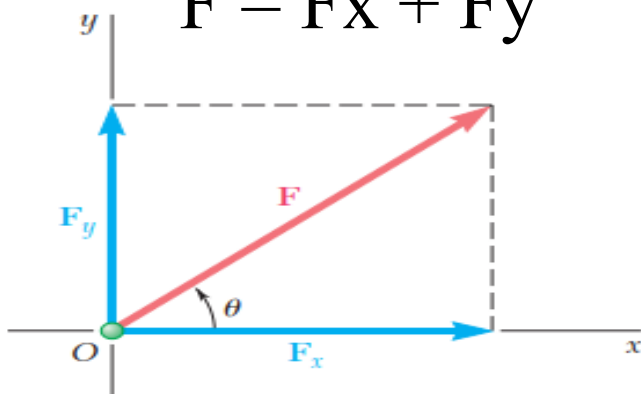

JQL

$$F' = F'_x + F'_y$$

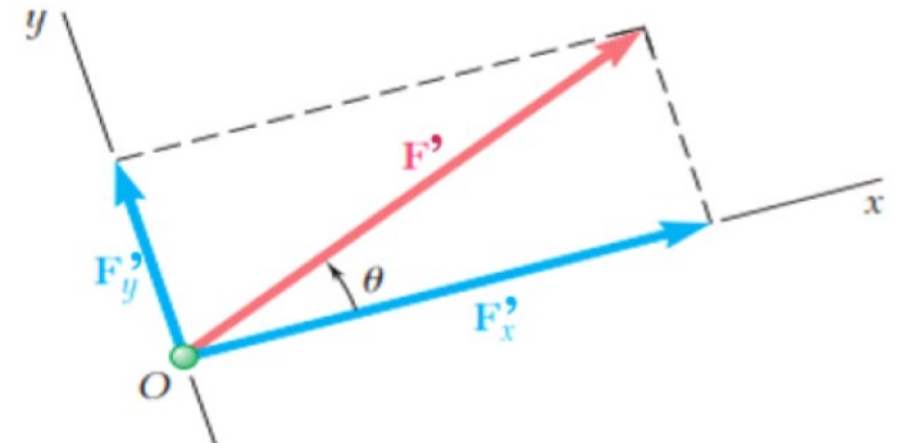

FORCE VECTORS

Addition of a System of Coplanar Forces

- ▶ *Figures below show that the sense of direction of each force component is represented graphically by the arrowhead*
- ▶ *For solving problems however, we need to establish a notation for representing the directional sense of the rectangular components*
- ▶ *The two ways that we will use are:*
 - *The Scalar Notation*
 - *Cartesian Vector Notation*

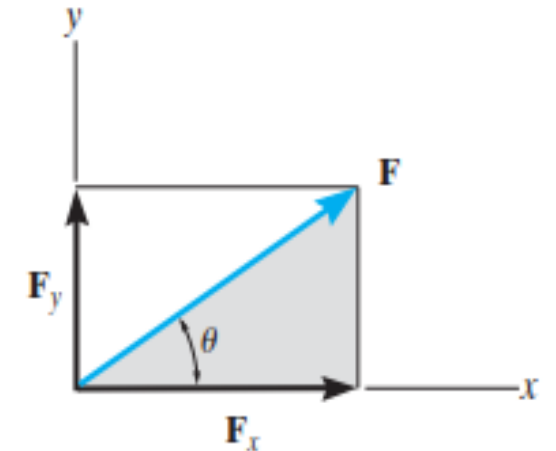
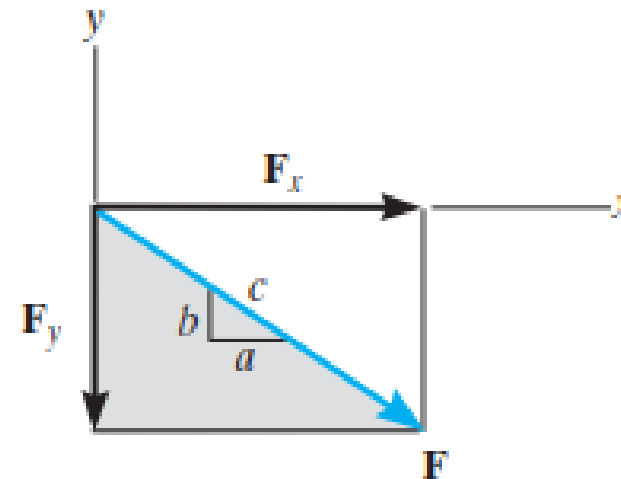

FORCE VECTORS

Addition of a System of Coplanar Forces

THE SCALAR NOTATION

► The rectangular components of force F shown are found using the parallelogram law, so that $F = F_x + F_y$.

► Because these components form a right triangle, they can be determined from

$$F_x = F \cos \theta \quad \text{and} \quad F_y = F \sin \theta$$

$$\tan \theta = \frac{F_y}{F_x} \quad \text{and} \quad F_x^2 + F_y^2 = F^2$$

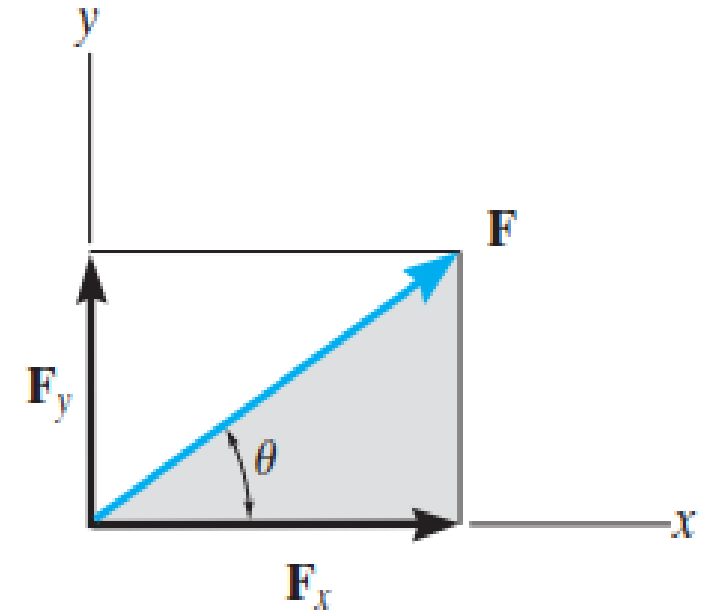

FORCE VECTORS

Addition of a System of Coplanar Forces

THE SCALAR NOTATION

- ▶ Instead of using the angle θ , however, the direction of F can also be defined using a small “slope” triangle
- ▶ Since this triangle and the larger shaded triangle are similar, the proportional length of the sides gives $\frac{F_x}{F} = \frac{a}{c}$ and $\frac{F_y}{F} = \frac{b}{c}$
- ▶ Below shows the force notation using the scalar method

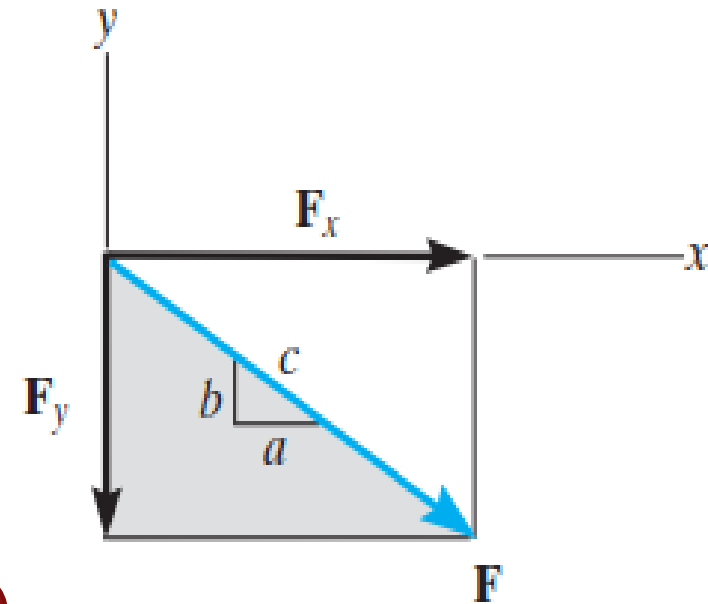

100 N ←

-100 N

173 N ↑

+173 N

240 N →

+240 N

100 N ↓

-100 N

FORCE VECTORS

Addition of a System of Coplanar Forces

THE CARTESIAN VECTOR NOTATION

- ▶ It is also possible to represent the x and y components of a force in terms of Cartesian unit vectors \mathbf{i} and \mathbf{j} .
- ▶ They are called unit vectors because they have a dimensionless magnitude of 1, and so they can be used to designate the directions of the x and y axes, respectively
- ▶ This method makes vector algebra very easy and it becomes advantageous when solving problems in 3D

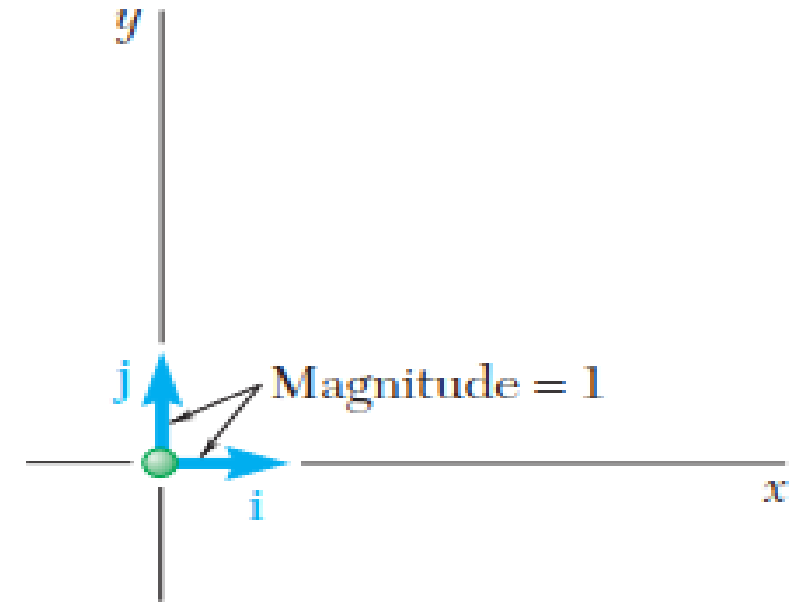

FORCE VECTORS

Addition of a System of Coplanar Forces

THE CARTESIAN VECTOR NOTATION

- ▶ Recalling the definition of the product of a scalar and a vector, we note that the rectangular components F_x and F_y of a force F may be obtained by multiplying respectively the unit vectors \mathbf{i} and \mathbf{j} by appropriate scalars
- ▶ We write $F_x = F_x \mathbf{i}$ & $F_y = F_y \mathbf{j}$ $\implies F = F_x + F_y$ $\implies F = F_x \mathbf{i} + F_y \mathbf{j}$

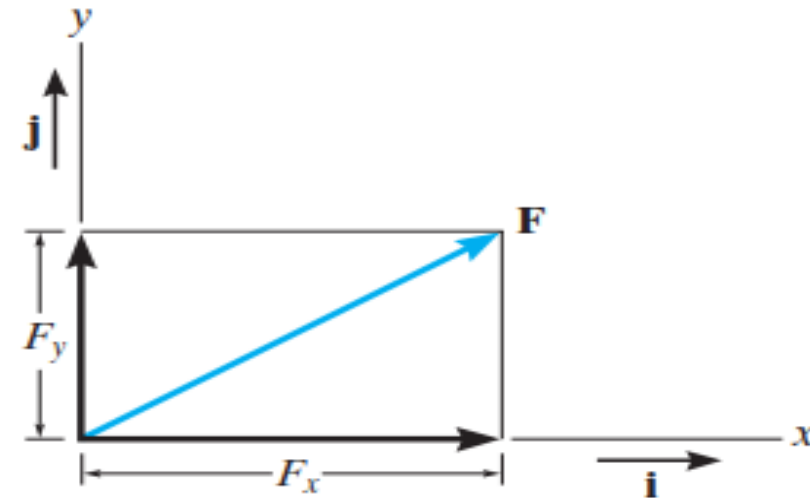
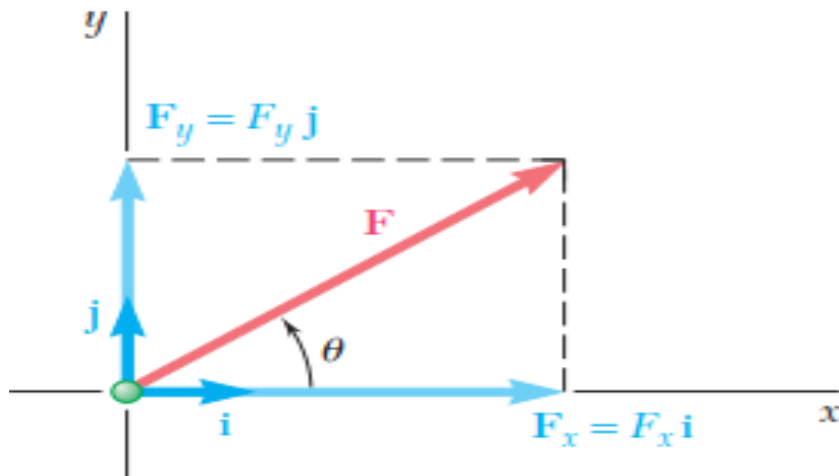

FORCE VECTORS

Addition of a System of Coplanar Forces

THE CARTESIAN VECTOR NOTATION

- ▶ We note that the scalar component F_x is positive when the vector component F_x has the same sense as the unit vector i (i.e., the same sense as the positive x axis) and is negative when F_x has the opposite sense
- ▶ A similar conclusion may be drawn regarding the sign of the scalar component F_y
- ▶ $F = F_x i + F_y j$ & $F' = F'_x i + F'_y (-j) \longrightarrow F' = F'_x i - F'_y j$

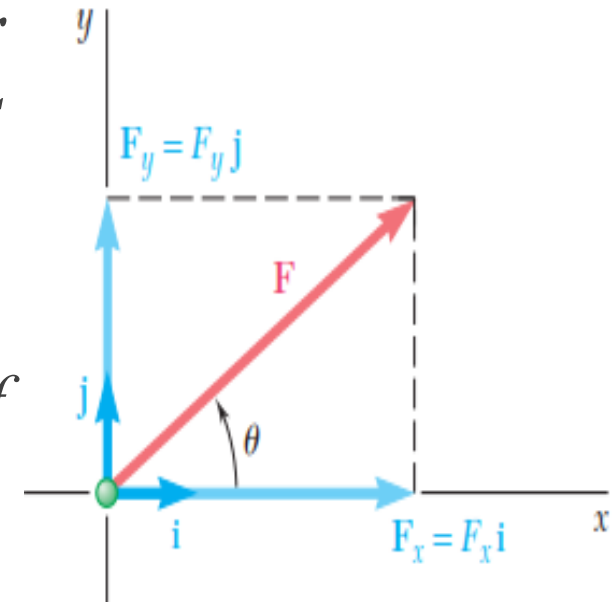

FORCE VECTORS

Addition of a System of Coplanar Forces

EXAMPLES 2-1

- ▶ A force of 800 N is exerted on a bolt A as shown. Determine the horizontal and vertical components of the force
- ▶ In order to obtain the correct sign for the scalar components F_x and F_y , the value $180^\circ - 35^\circ = 145^\circ$ should be substituted for θ in

$$F_x = F\cos\theta \text{ and } F_y = F\sin\theta$$

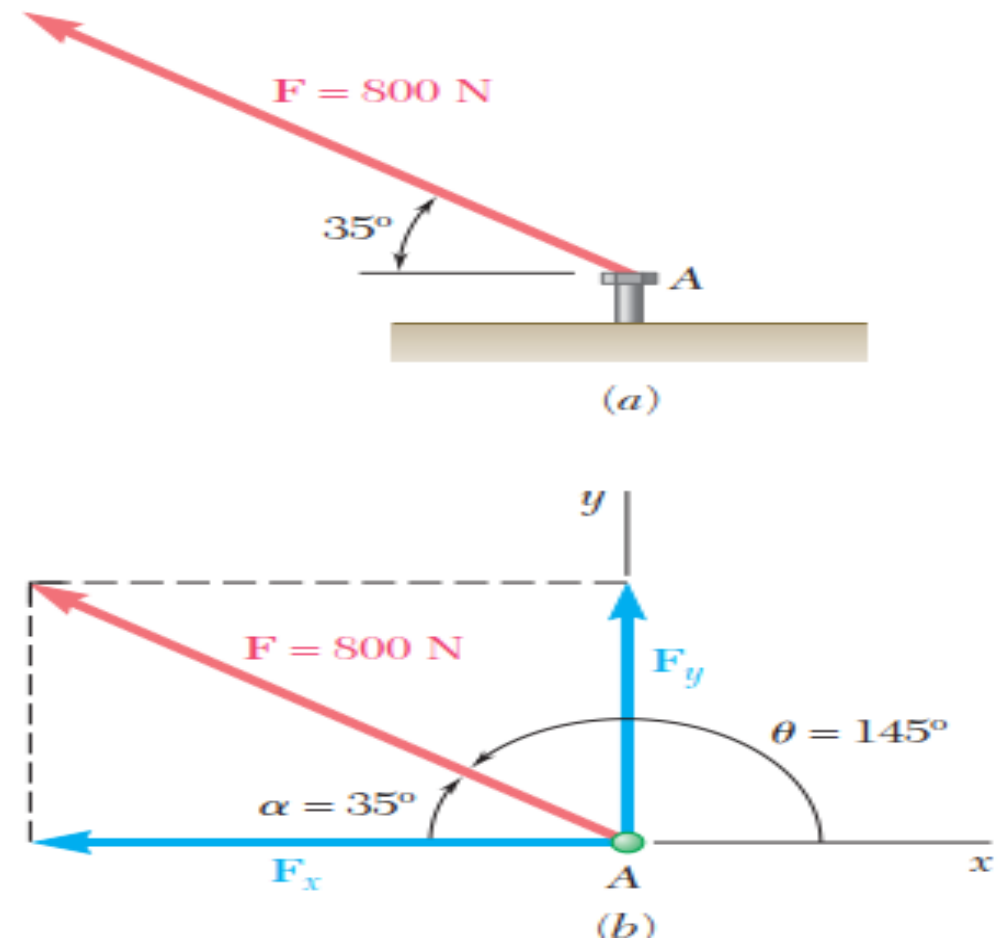

FORCE VECTORS

Addition of a System of Coplanar Forces

EXAMPLES 2-1

- ▶ However, it will be found more practical to determine by inspection the signs of F_x and F_y and to use the trigonometric functions of the angle $\alpha = 35^\circ$.

- ▶ We write, therefore

$$F_x = -F \cos \alpha = -(800 \text{ N}) \cos 35^\circ = -655 \text{ N}$$

$$F_y = +F \sin \alpha = +(800 \text{ N}) \sin 35^\circ = +459 \text{ N}$$

- ▶ In Cartesian notation we have

$$\mathbf{F}_x = -(655 \text{ N})\mathbf{i} \quad \mathbf{F}_y = +(459 \text{ N})\mathbf{j}$$

- ▶ Therefore, $\mathbf{F} = -(655 \text{ N})\mathbf{i} + (459 \text{ N})\mathbf{j}$

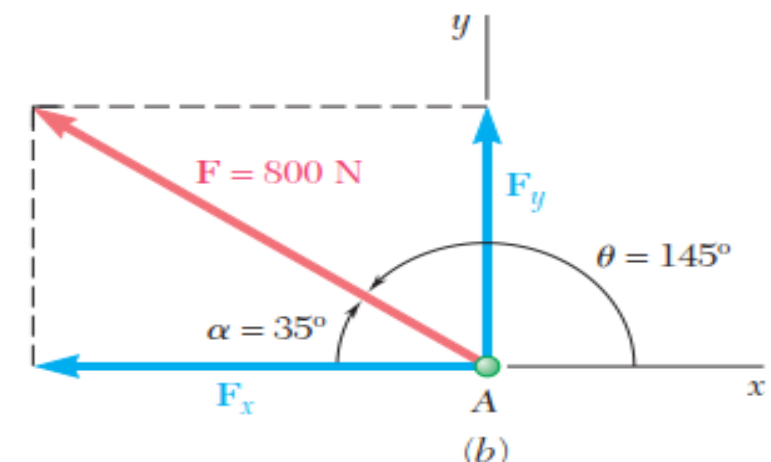
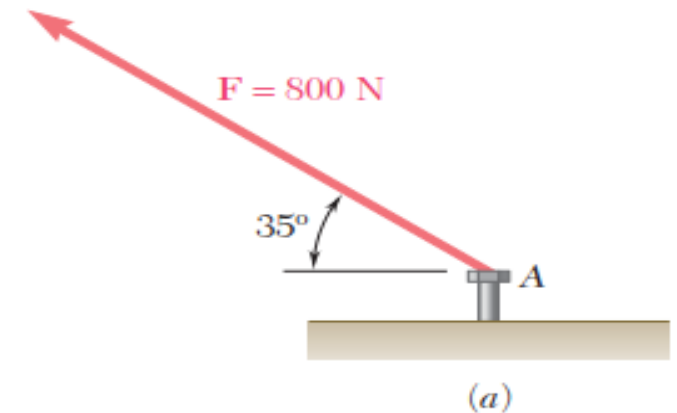

FORCE VECTORS

Addition of a System of Coplanar Forces

EXAMPLES 2-2

- ▶ A man pulls with a force of 300 N on a rope attached to a building, as shown. What are the horizontal and vertical components of the force exerted by the rope at point A?
- ▶ It is seen from Fig. that $F_x = +(300 \text{ N}) \cos\alpha$, $F_y = -(300 \text{ N}) \sin\alpha$
- ▶ Observing that $AB = 10\text{m}$, $\cos\alpha = 8/AB = 4/5$
- ▶ $\sin\alpha = 6/AB = 3/5$
- ▶ $F_x = +(300 \text{ N})4/5 = +240\text{N}$ & $F_y = -(300 \text{ N})3/5 = -180\text{N}$
- ▶ $F = (240 \text{ N})i - (180 \text{ N})j$

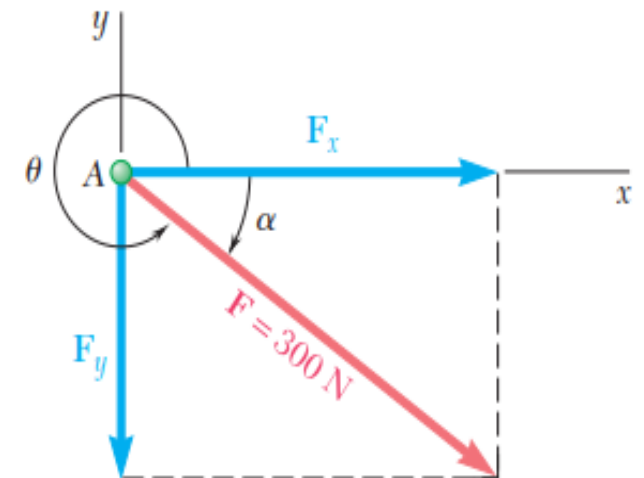
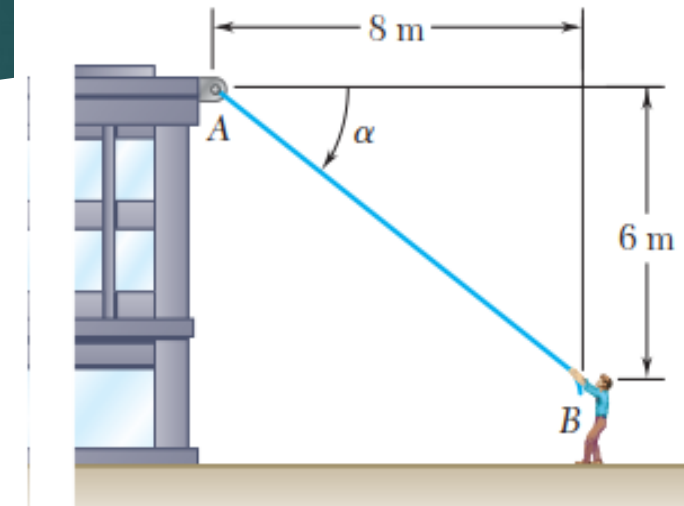

FORCE VECTORS

Addition of a System of Coplanar Forces

THE COPLANAR FORCE RESULTANTS

- ▶ *We can now use either of the two methods just described to determine the resultant of several coplanar forces*
- ▶ *To do this, each force is first resolved into its x and y components, and then the respective components are added using scalar algebra since they are collinear*
- ▶ *The resultant force is then formed by adding the resultant components using the parallelogram law*

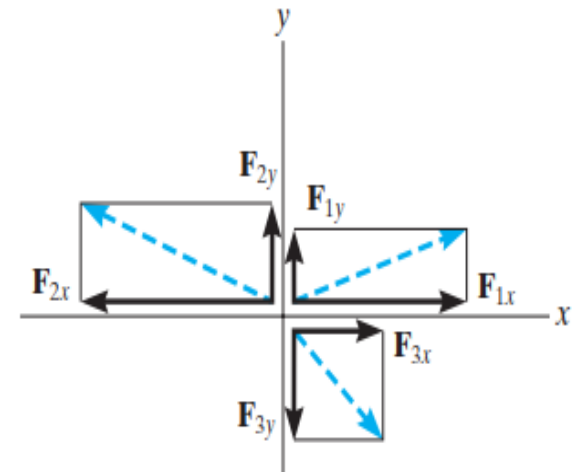
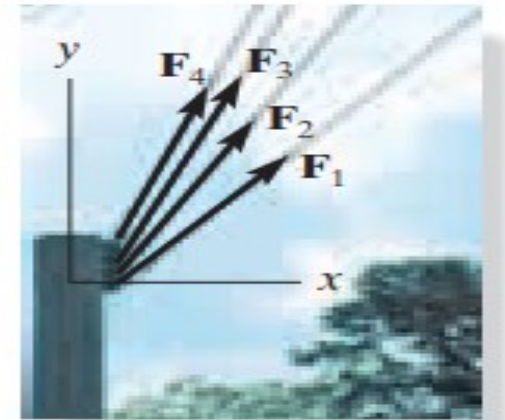

FORCE VECTORS

Addition of a System of Coplanar Forces

THE COPLANAR FORCE RESULTANTS

- ▶ Consider the three concurrent forces shown which have x and y components as shown
- ▶ Using Cartesian vector notation (*or scalar*), each force is first represented as a Cartesian vector, i.e

$$\mathbf{F}_1 = F_{1x}\mathbf{i} + F_{1y}\mathbf{j}, \quad \mathbf{F}_2 = -F_{2x}\mathbf{i} + F_{2y}\mathbf{j}, \quad \mathbf{F}_3 = F_{3x}\mathbf{i} - F_{3y}\mathbf{j}$$

- The vector resultant is therefore

$$\mathbf{F}_R = \mathbf{F}_1 + \mathbf{F}_2 + \mathbf{F}_3$$

$$\mathbf{F}_R = F_{1x}\mathbf{i} + F_{1y}\mathbf{j} - F_{2x}\mathbf{i} + F_{2y}\mathbf{j} + F_{3x}\mathbf{i} - F_{3y}\mathbf{j} = (F_{Rx})\mathbf{i} + (F_{Ry})\mathbf{j}$$

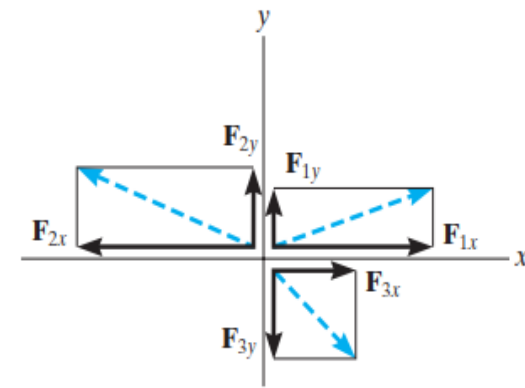
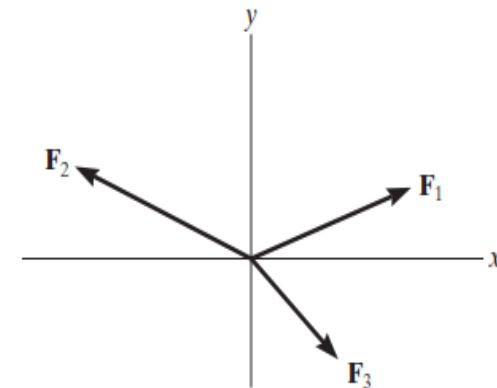

FORCE VECTORS

Addition of a System of Coplanar Forces

THE COPLANAR FORCE RESULTANTS

$$\begin{array}{l} \rightarrow \\ + \end{array} \quad (F_R)_x = F_{1x} - F_{2x} + F_{3x}$$

$$\begin{array}{l} + \\ \uparrow \end{array} \quad (F_R)_y = F_{1y} + F_{2y} - F_{3y}$$

- ▶ If scalar notation is used, then indicating the positive directions of components along the x and y axes with symbolic arrows, we have
- ▶ We can represent the components of the resultant force of any number of coplanar forces symbolically by the algebraic sum of the x and y components of all the forces $\longrightarrow R_x = \Sigma F_x \quad R_y = \Sigma F_y$
- ▶ Once these components are determined, they may be sketched along the x and y axes with their proper sense of direction, and the resultant force can be determined from vector addition, as shown in next slide

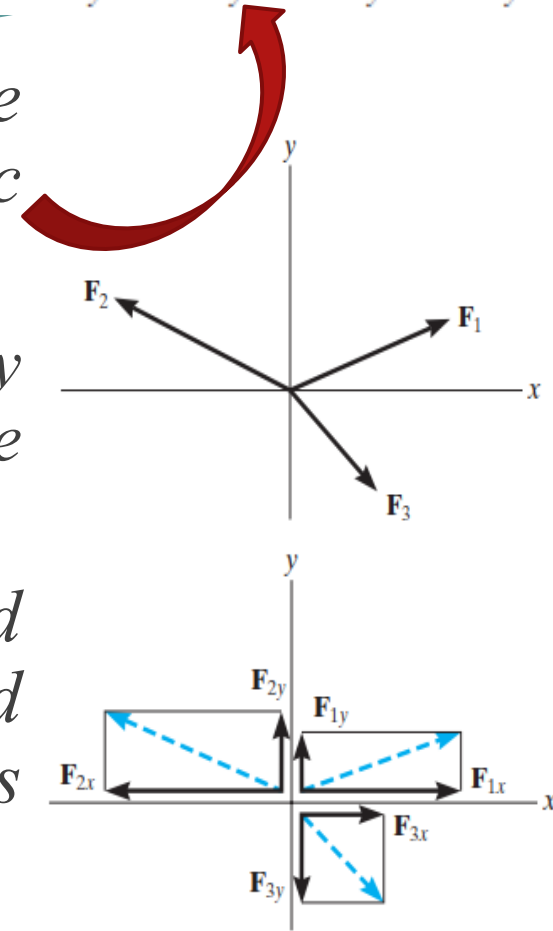

FORCE VECTORS

Addition of a System of Coplanar Forces

THE COPLANAR FORCE RESULTANTS

► From this sketch, the magnitude of F_R is then found from the Pythagorean theorem $\longrightarrow F_R = \sqrt{(F_R)_x^2 + (F_R)_y^2}$

► Also, the angle θ , which specifies the direction of the resultant force, is determined from trigonometry:

$$\theta = \tan^{-1} \left| \frac{(F_R)_y}{(F_R)_x} \right|$$

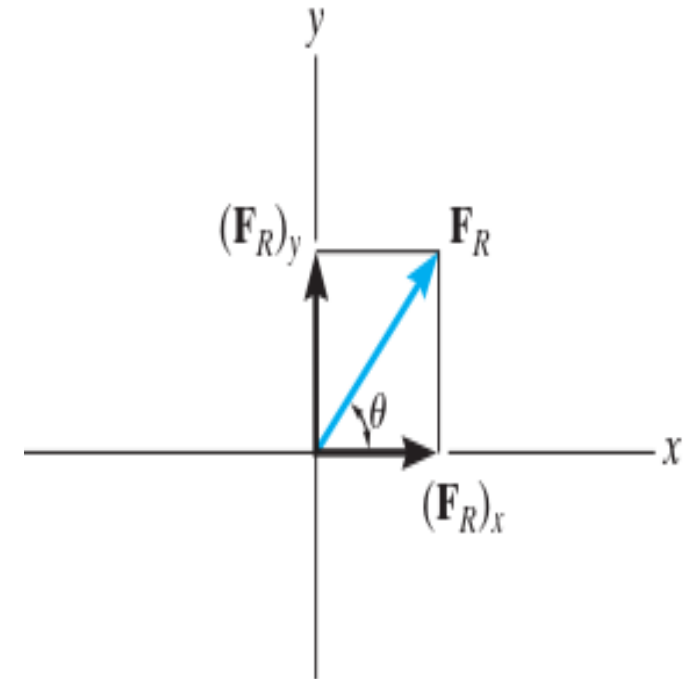

FORCE VECTORS

Addition of a System of Coplanar Forces

THE COPLANAR FORCE RESULTANTS

Important Notes:

- ▶ *The resultant of several coplanar forces can easily be determined if an x, y coordinate system is established and the forces are resolved along the axes*
- ▶ *The direction of each force is specified by the angle its line of action makes with one of the axes, or by a slope triangle.*
- ▶ *The orientation of the x and y axes is arbitrary, and their positive direction can be specified by the Cartesian unit vectors \mathbf{i} and \mathbf{j} .*

FORCE VECTORS

Addition of a System of Coplanar Forces

THE COPLANAR FORCE RESULTANTS

Important Notes:

- ▶ The x and y components of the resultant force are simply the algebraic addition of the components of all the coplanar forces.
- ▶ The magnitude of the resultant force is determined from the Pythagorean theorem, and when the resultant components are sketched on the x and y axes, and the direction θ can be determined from trigonometry

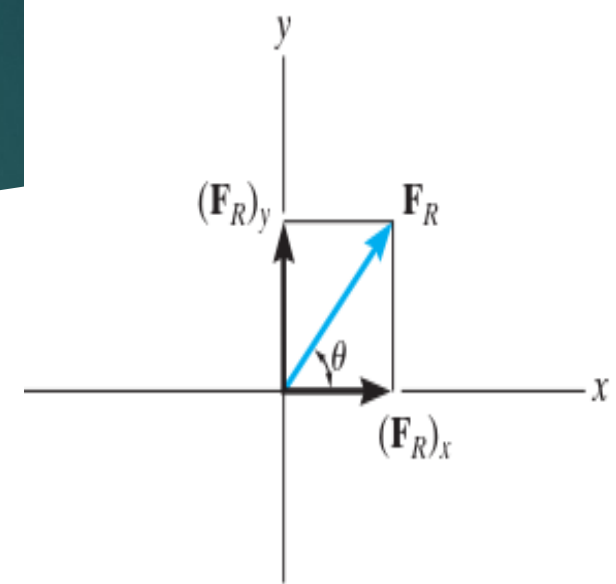

$$F_R = \sqrt{(F_R)_x^2 + (F_R)_y^2}$$

$$\theta = \tan^{-1} \left| \frac{(F_R)_y}{(F_R)_x} \right|$$

FORCE VECTORS

Addition of a System of Coplanar Forces

EXAMPLES 2-3

- ▶ *Inspect the Fig. shown and determine the magnitude and direction of the resultant force.*
- ▶ *Scalar notation method.*
- ▶ *First we resolve each force into its x and y components, then we sum these components algebraically*

$$\begin{aligned} \rightarrow (F_R)_x &= \Sigma F_x; & (F_R)_x &= 600 \cos 30^\circ \text{ N} - 400 \sin 45^\circ \text{ N} \\ & & &= 236.8 \text{ N} \rightarrow \end{aligned}$$

$$\begin{aligned} +\uparrow (F_R)_y &= \Sigma F_y; & (F_R)_y &= 600 \sin 30^\circ \text{ N} + 400 \cos 45^\circ \text{ N} \\ & & &= 582.8 \text{ N} \uparrow \end{aligned}$$

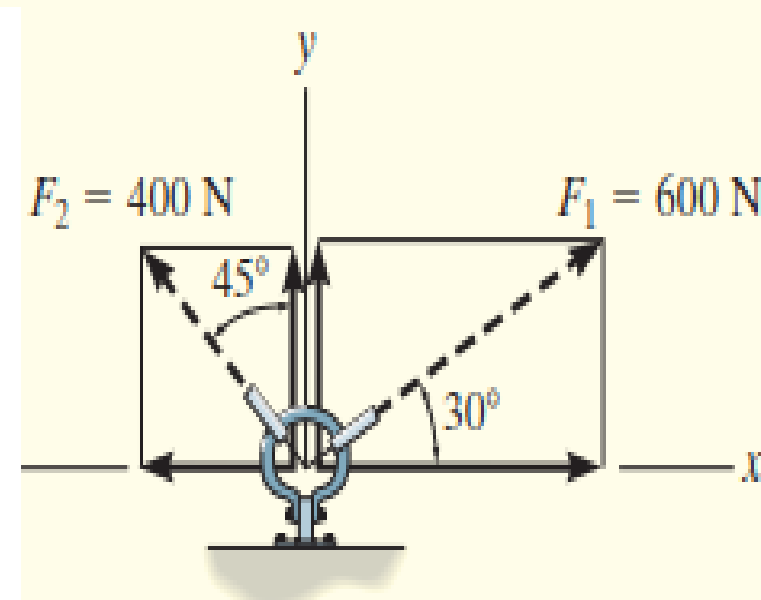
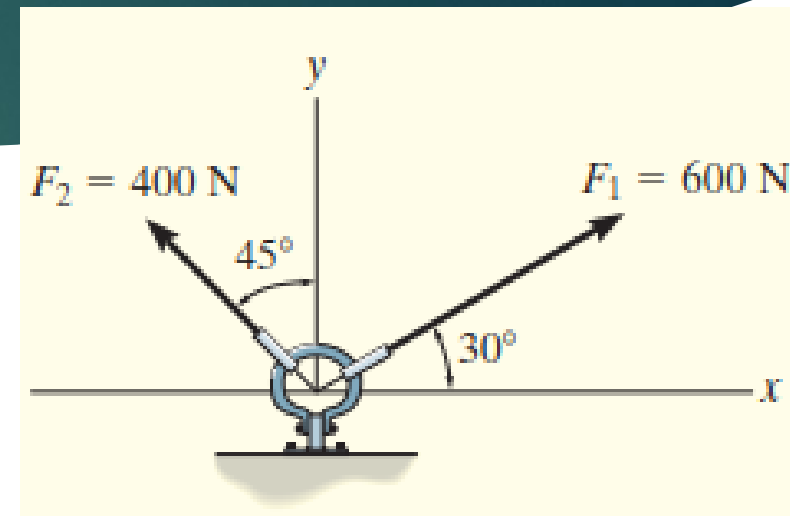

FORCE VECTORS

Addition of a System of Coplanar Forces

EXAMPLES 2-3

- ▶ The resultant force, shown in the Fig., has a magnitude of

$$F_R = \sqrt{(236.8 \text{ N})^2 + (582.8 \text{ N})^2}$$

$$= 629 \text{ N}$$

- ▶ From the vector addition the direction of the resultant force is calculated as

$$\theta = \tan^{-1}\left(\frac{582.8 \text{ N}}{236.8 \text{ N}}\right) = 67.9^\circ$$

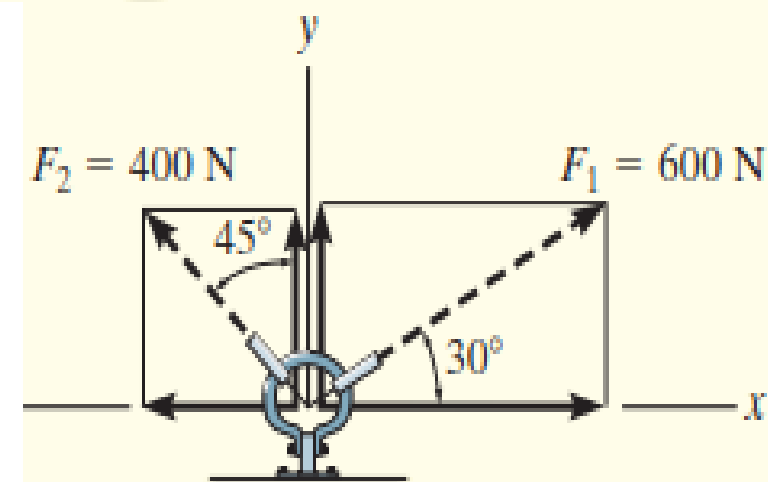
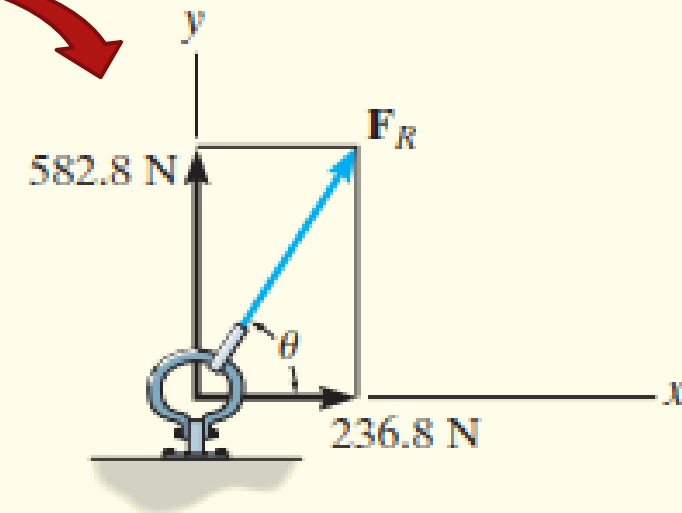

FORCE VECTORS

Addition of a System of Coplanar Forces

EXAMPLES 2-3

- ▶ Cartesian Vector Notation method
- ▶ From Fig shown, each force is first expressed as a Cartesian vector
- ▶ $F_1 = \{600\cos 30^\circ \mathbf{i} + 600\sin 30^\circ \mathbf{j}\} \text{N}$
- ▶ $F_2 = \{-400\sin 45^\circ \mathbf{i} + 400\cos 45^\circ \mathbf{j}\} \text{N}$ then we know
- ▶ $F_R = F_1 + F_2 = (600\cos 30^\circ \text{N} - 400\sin 45^\circ \text{N})\mathbf{i} + (600\sin 30^\circ \text{N} + 400\cos 45^\circ \text{N})\mathbf{j}$
- ▶ $F_R = \{236.8\mathbf{i} + 582.8\mathbf{j}\} \text{N}$
- ▶ The magnitude and direction of F_R are determined in the same manner as before.

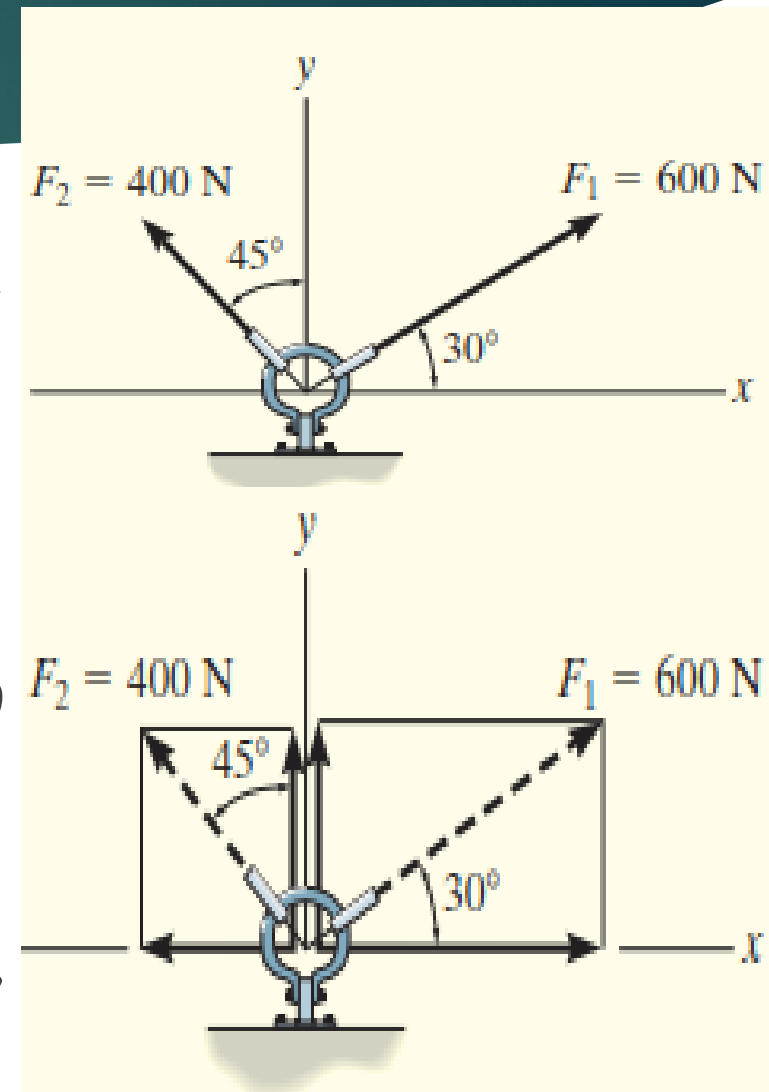

FORCE VECTORS

Addition of a System of Coplanar Forces

EXAMPLES 2-3

- ▶ *Comparing the two methods of solution, notice that the use of scalar notation is more efficient and easy since the components can be found directly, without first having to express each force as a Cartesian vector before adding the components*
- ▶ *However, you will appreciate that Cartesian vector analysis is very beneficial for solving three-dimensional (3D) problems*

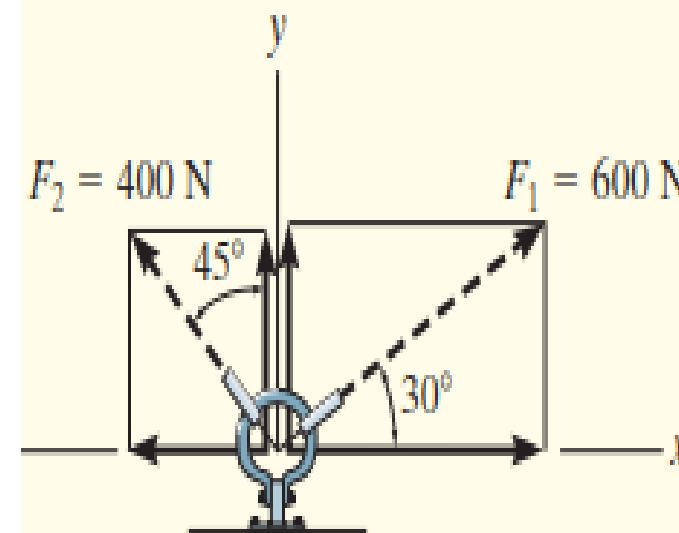
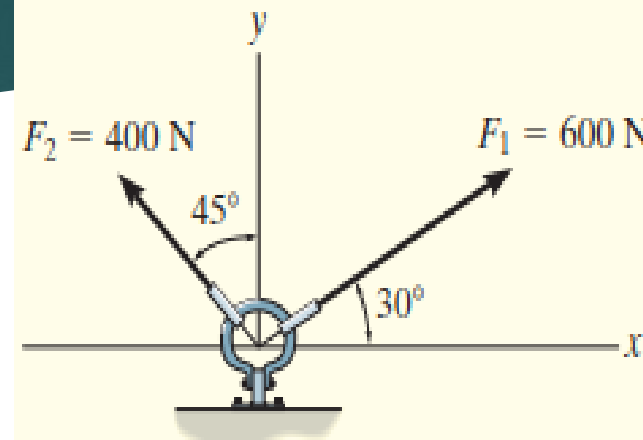

FORCE VECTORS

Addition of a System of Coplanar Forces

EXAMPLES 2-3a

Question for thinking

- If the resultant force acting on the bracket is required to be a minimum, determine the magnitudes of F_1 and the resultant force. Set $\phi = 30^\circ$

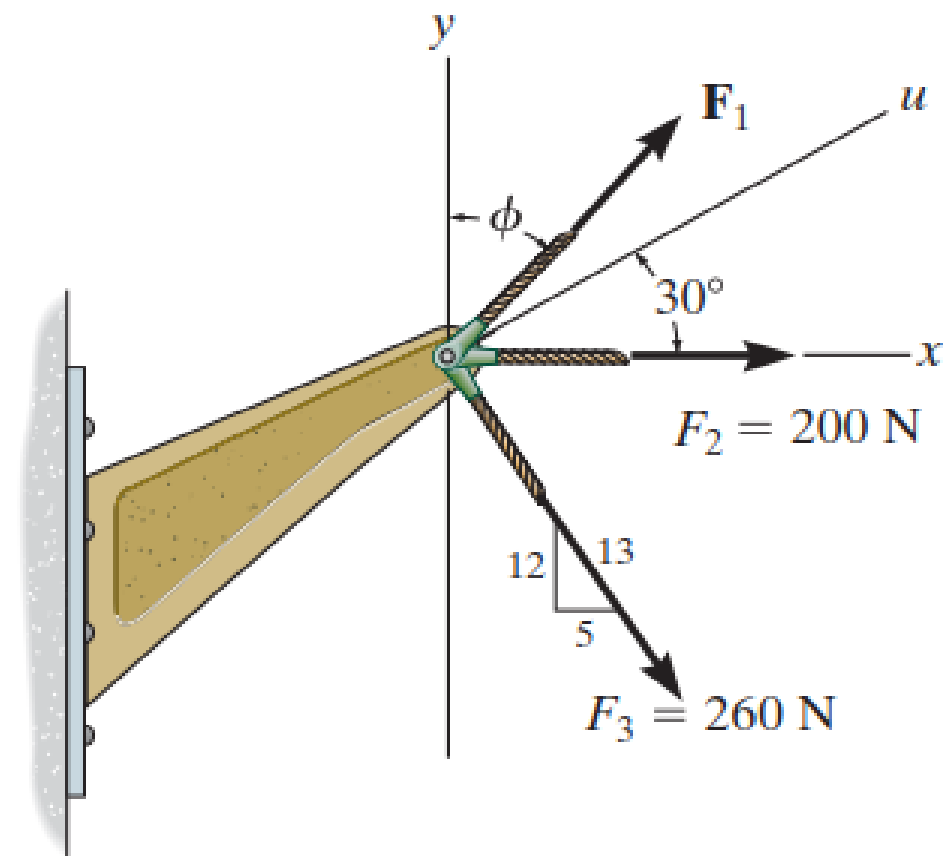

FORCE VECTORS

Addition of a System of Coplanar Forces

EXAMPLES 2-3a

SOLUTION

Rectangular Components: By referring to Fig. *a*, the x and y components of \mathbf{F}_1 , \mathbf{F}_2 , and \mathbf{F}_3 can be written as

$$(F_1)_x = F_1 \sin 30^\circ = 0.5F_1 \qquad (F_1)_y = F_1 \cos 30^\circ = 0.8660F_1$$

$$(F_2)_x = 200 \text{ N} \qquad (F_2)_y = 0$$

$$(F_3)_x = 260 \left(\frac{5}{13} \right) = 100 \text{ N} \qquad (F_3)_y = 260 \left(\frac{12}{13} \right) = 240 \text{ N}$$

Resultant Force: Summing the force components algebraically along the x and y axes,

$$\rightarrow \Sigma(F_R)_x = \Sigma F_x; \quad (F_R)_x = 0.5F_1 + 200 + 100 = 0.5F_1 + 300$$

$$+\uparrow \Sigma(F_R)_y = \Sigma F_y; \quad (F_R)_y = 0.8660F_1 - 240$$

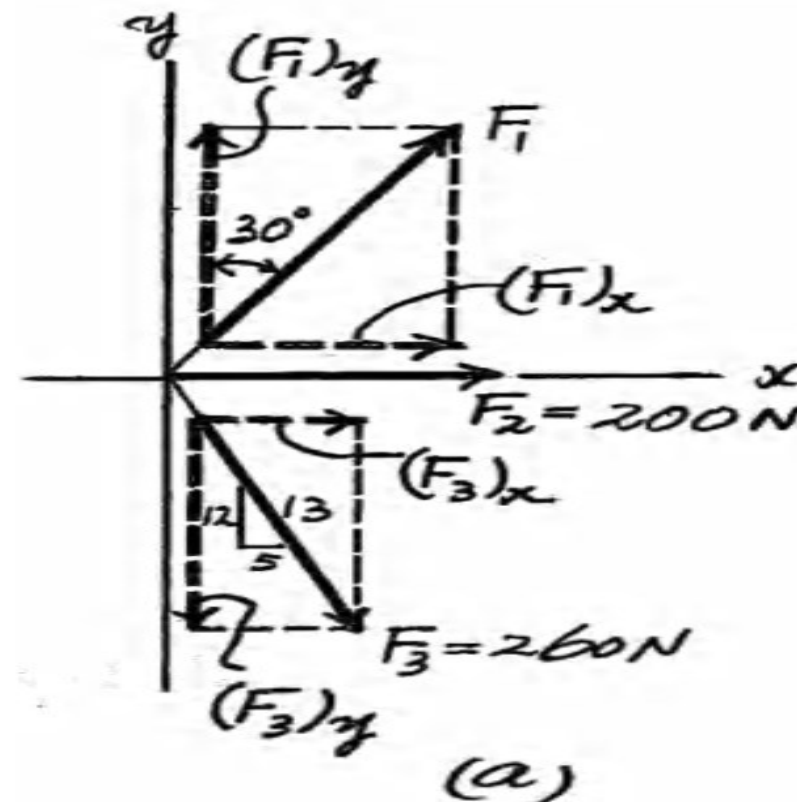

FORCE VECTORS

Addition of a System of Coplanar ForcesEXAMPLES 2-3a**SOLUTION**

The magnitude of the resultant force \mathbf{F}_R is

$$\begin{aligned} F_R &= \sqrt{(F_R)_x^2 + (F_R)_y^2} \\ &= \sqrt{(0.5F_1 + 300)^2 + (0.8660F_1 - 240)^2} \\ &= \sqrt{F_1^2 - 115.69F_1 + 147\,600} \quad \text{Eqn 1} \end{aligned}$$

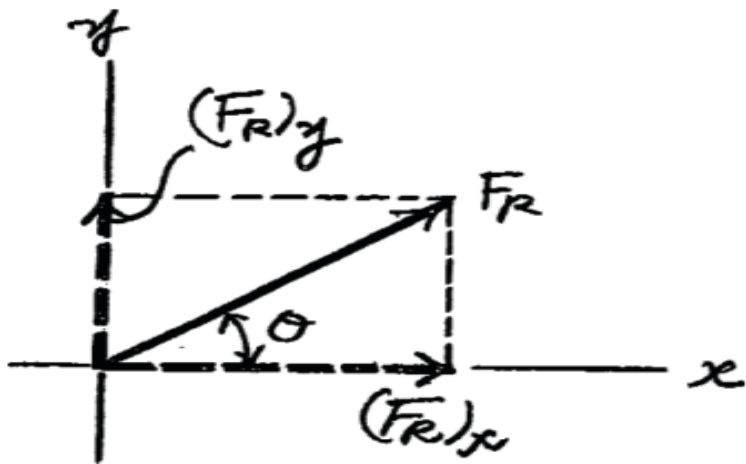

Thus,

$$F_R^2 = F_1^2 - 115.69F_1 + 147\,600 \quad \text{Eqn 2}$$

The first derivative of Eq. (2) is

$$2F_R \frac{dF_R}{dF_1} = 2F_1 - 115.69 \quad \text{Eqn 3}$$

For \mathbf{F}_R to be minimum, $\frac{dF_R}{dF_1} = 0$. Thus, from Eq. (3)

$$2F_R \frac{dF_R}{dF_1} = 2F_1 - 115.69 = 0$$

$$F_1 = 57.846 \text{ N} = 57.8 \text{ N}$$

from Eq. (1),

$$F_R = \sqrt{(57.846)^2 - 115.69(57.846) + 147\,600} = 380 \text{ N}$$

FORCE VECTORS

EQUILIBRIUM OF A PARTICLE (in 2D)

- ▶ *We now discussed problems concerning forces that result to have the magnitude of ZERO for the resultant*
- ▶ *Although it has not occurred in any of the problems considered so far, it is quite possible for the resultant to be zero*
- ▶ *In such a case, the net effect of the given forces is zero, and the particle is said to be in Equilibrium*

FORCE VECTORS

EQUILIBRIUM OF A PARTICLE (in 2D)

- ▶ *A particle which is acted upon by two forces will be in equilibrium if the two forces have the same magnitude and the same line of action but opposite sense*
- ▶ *The resultant of the two forces is then zero*
- ▶ *Another case of equilibrium of a particle is where four forces are acting on A*

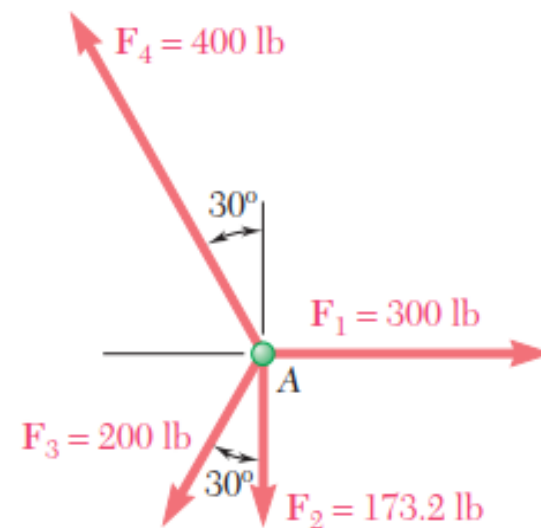
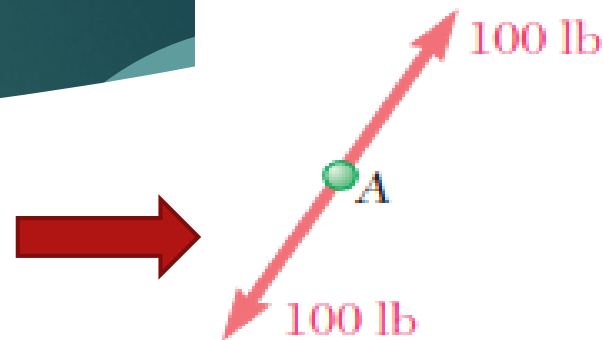

FORCE VECTORS

EQUILIBRIUM OF A PARTICLE (in 2D)

- ▶ In this case the resultant of the given forces is determined by the polygon rule
- ▶ Starting from point O with F_1 and arranging the forces in tip-to-tail fashion, we find that the tip of F_4 coincides with the starting point .
- ▶ Thus the resultant R of the given system of forces is zero, and the particle is in Equilibrium

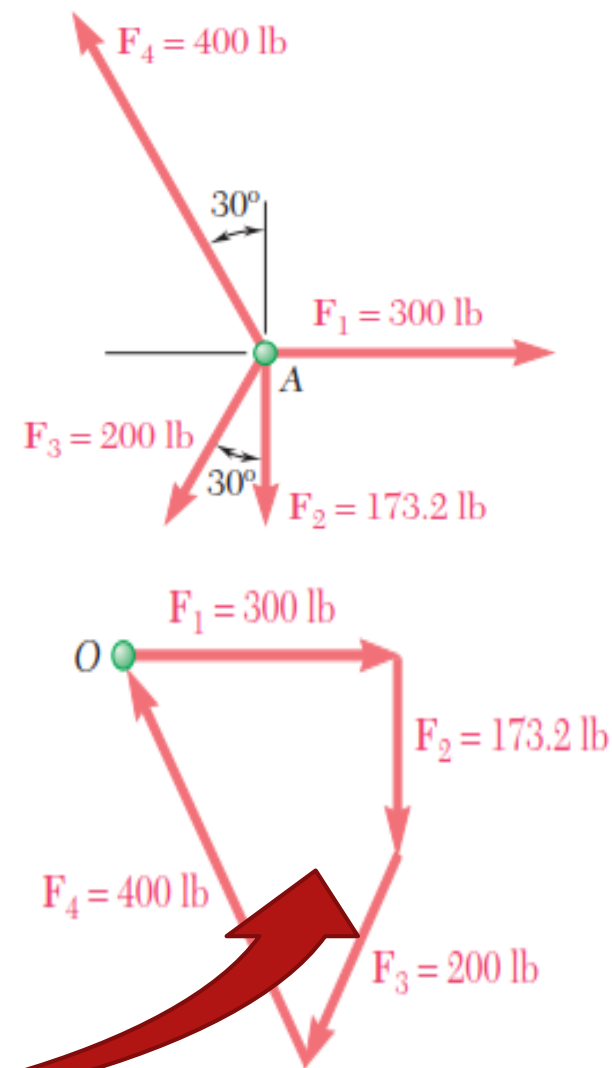

FORCE VECTORS

EQUILIBRIUM OF A PARTICLE (in 2D)

▶ The closed polygon drawn provides a graphical expression of the equilibrium of A

▶ To express algebraically the conditions for the equilibrium of a particle, we write

$$\mathbf{R} = \Sigma \mathbf{F} = \mathbf{0}$$

▶ Resolving each force F into rectangular components, we have

$$\Sigma(F_x \mathbf{i} + F_y \mathbf{j}) = \mathbf{0} \quad \text{or} \quad (\Sigma F_x) \mathbf{i} + (\Sigma F_y) \mathbf{j} = \mathbf{0}$$

▶ We conclude that the necessary and sufficient conditions for the equilibrium of a particle are

$$\Sigma F_x = 0 \quad \Sigma F_y = 0$$

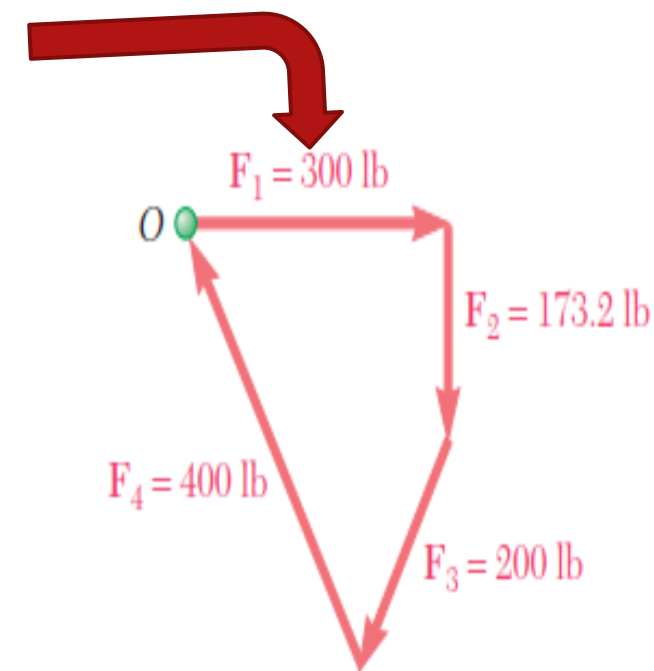

FORCE VECTORS

EQUILIBRIUM OF A PARTICLE (in 2D)

- ▶ Returning to the particle shown, we check that the equilibrium conditions are satisfied
- ▶ We conclude that the necessary and sufficient conditions for the equilibrium of a particle are

$$\begin{aligned}\Sigma F_x &= 300 \text{ lb} - (200 \text{ lb}) \sin 30^\circ - (400 \text{ lb}) \sin 30^\circ \\ &= 300 \text{ lb} - 100 \text{ lb} - 200 \text{ lb} = 0\end{aligned}$$

$$\begin{aligned}\Sigma F_y &= -173.2 \text{ lb} - (200 \text{ lb}) \cos 30^\circ + (400 \text{ lb}) \cos 30^\circ \\ &= -173.2 \text{ lb} - 173.2 \text{ lb} + 346.4 \text{ lb} = 0\end{aligned}$$

- ▶ **Recall Newton's 1st Law of Motion!!!**

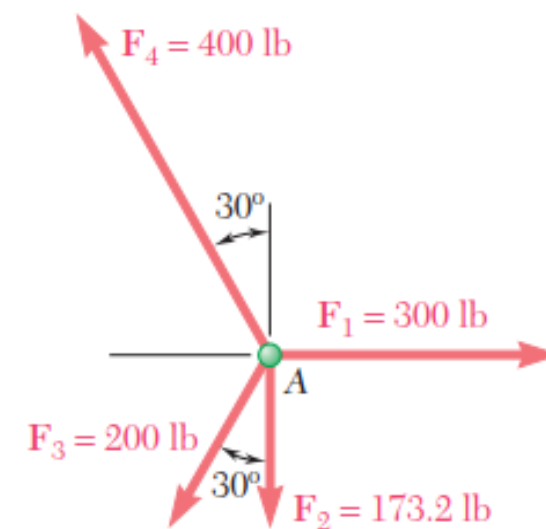

FORCE VECTORS

EQUILIBRIUM

OF A PARTICLE - FREE-BODY DIAGRAMS (in 2D)

- ▶ *In practice, a problem in engineering mechanics is derived from an actual physical situation*
- ▶ *A sketch showing the physical conditions of the problem is known as a space diagram*
- ▶ *A large number of problems involving actual structures, however, can be reduced to problems concerning the equilibrium of a particle.*
- ▶ *This is done by choosing a significant particle and drawing a separate diagram showing this particle and all the forces acting on it.*
- ▶ *Such a diagram is called a free-body diagram (FBD)*

FORCE VECTORS

EQUILIBRIUM

OF A PARTICLE - FREE-BODY DIAGRAMS (in 2D)

- ▶ The next demonstration explains how to draw a useful FBD
- ▶ Consider the 75-kg crate shown in the space diagram
- ▶ This crate was lying between two buildings, and it is now being lifted onto a truck, which will remove it
- ▶ The crate is supported by a vertical cable, which is joined at A to two ropes which pass over pulleys attached to the buildings at B and C
- ▶ It is desired to determine the tension in each of the ropes AB and AC

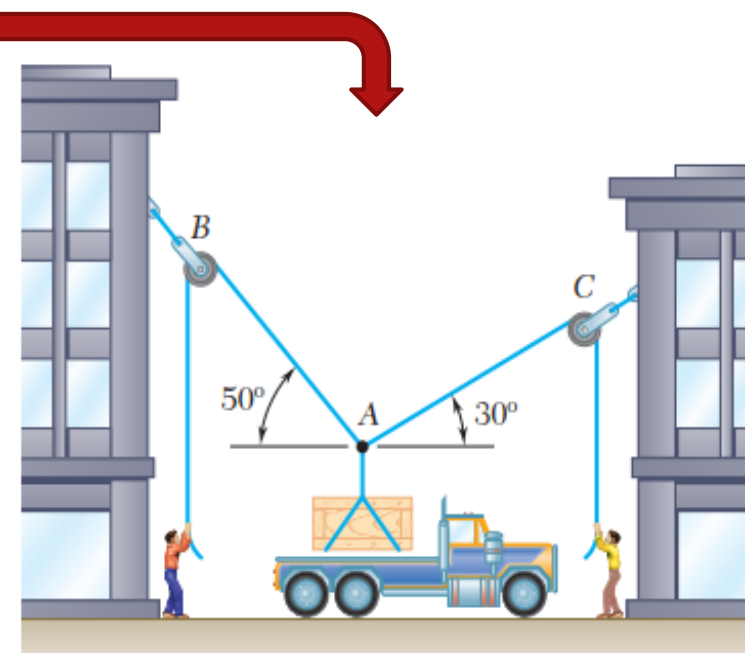

FORCE VECTORS

EQUILIBRIUM

OF A PARTICLE - FREE-BODY DIAGRAMS

- ▶ *In order to solve this problem, a free-body diagram showing a particle in equilibrium must be drawn*
- ▶ *The FBD shows the forces exerted on A by the vertical cable and the two ropes*
- ▶ *The force exerted by the cable is directed downward, and its magnitude is equal to the weight W of the crate*
- ▶ ***Note that only tension can occur in a rope***

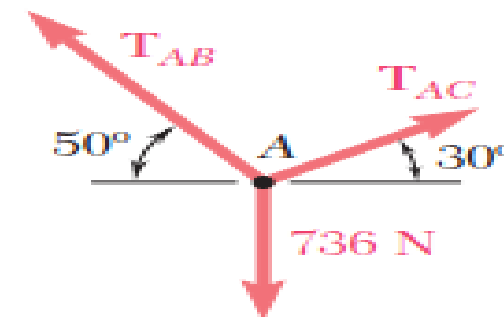
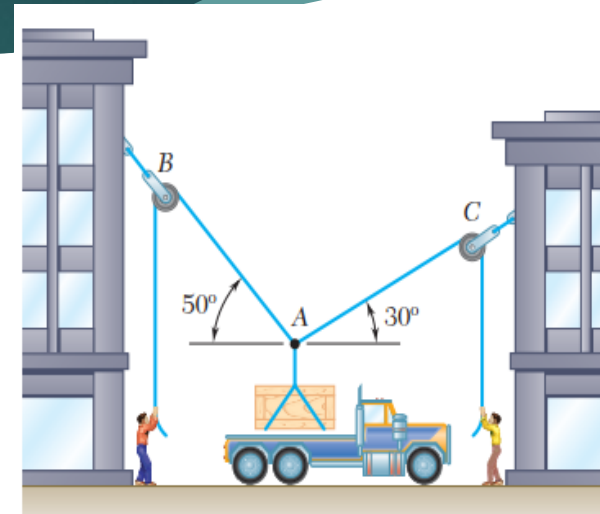

FORCE VECTORS

EQUILIBRIUM

OF A PARTICLE - FREE-BODY DIAGRAMS (in 2D)

- ▶ Since point A is in equilibrium, the three forces acting on it must form a closed triangle when drawn in tip-to-tail fashion
- ▶ The values T_{AB} and T_{AC} of the tension in the ropes may be found graphically if the triangle is drawn to scale, or they may be found by trigonometry
- ▶ If we use trigonometry method, we use the law of sines and write

$$\frac{T_{AB}}{\sin 60^\circ} = \frac{T_{AC}}{\sin 40^\circ} = \frac{736 \text{ N}}{\sin 80^\circ}$$

$$T_{AB} = 647 \text{ N} \quad T_{AC} = 480 \text{ N}$$

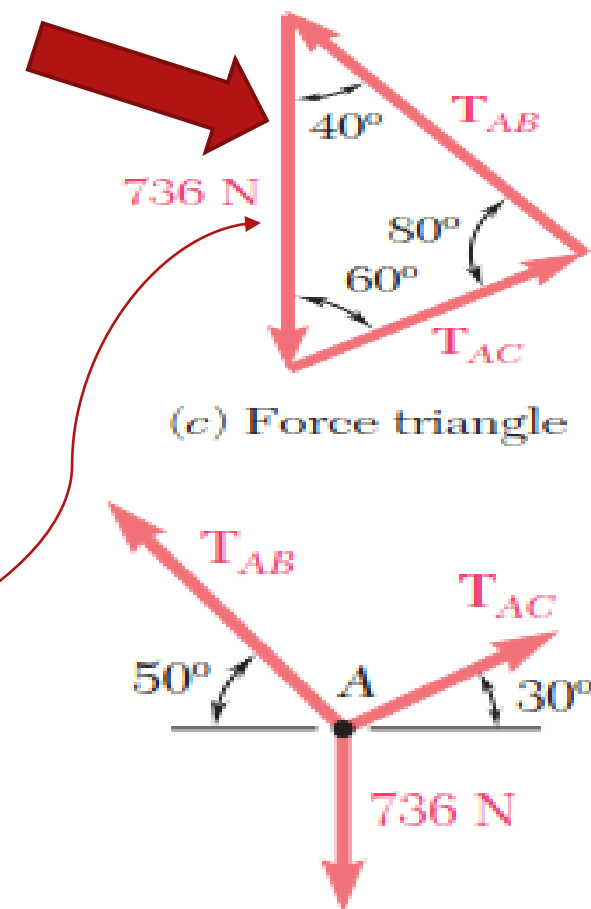

FORCE VECTORS IN SPACE (3D)

- ▶ *The problems considered in the first part of this chapter involved only two dimensions; they could be formulated and solved in a single plane*
- ▶ *This section will discuss problems involving the three dimensions (3D) of space*
- ▶ *The operations of vector algebra, when applied to solving problems in 3D, are greatly simplified if the vectors are first represented in **Cartesian vector form***

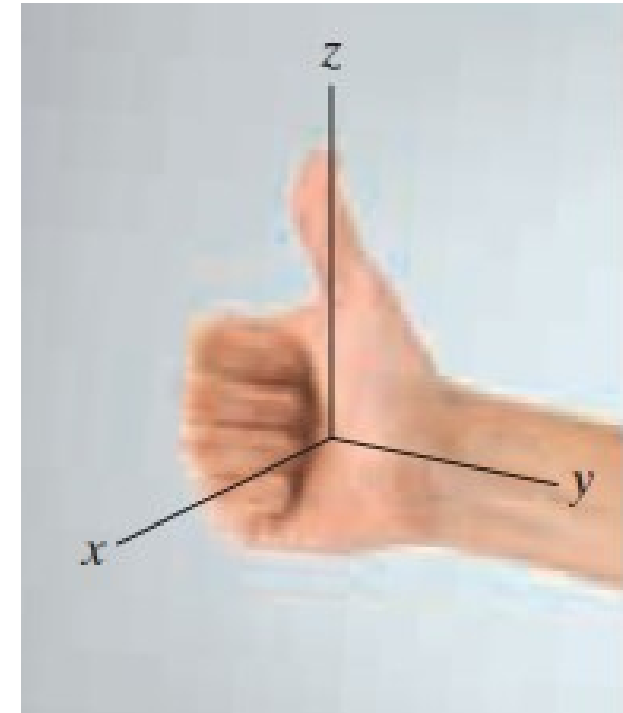

FORCE VECTORS IN SPACE (3D)

CARTESIAN VECTORS

Right-Handed Coordinate System:

- ▶ *The right-handed coordinate system will be used to develop the theory of vector algebra*
- ▶ *A rectangular coordinate system is said to be right-handed if the thumb of the right hand points in the direction of the positive z axis when the right-hand fingers are curled about this axis and directed from the positive x towards the positive y axis*

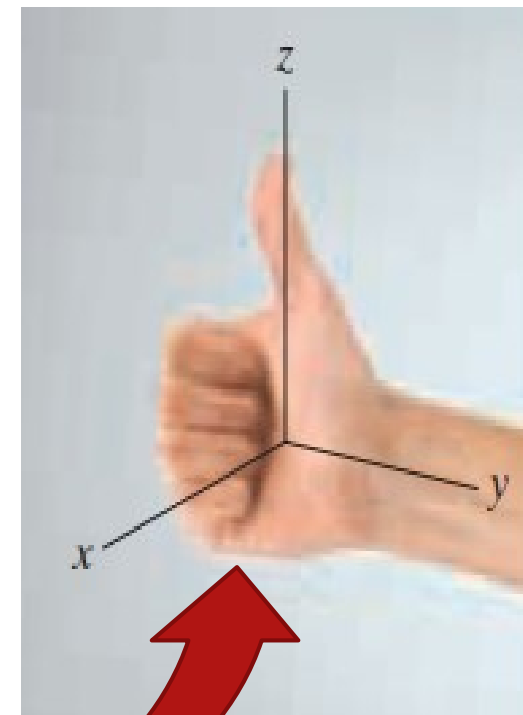

FORCE VECTORS IN SPACE (3D)

CARTESIAN VECTORS

Rectangular Components of a Vector.

- ▶ A vector A may have one, two, or three rectangular components along the x , y , z coordinate axes, depending on how the vector is oriented relative to the axes
- ▶ In general, though, when A is directed within an octant of the x , y , z , then by two successive applications of the parallelogram law, we may resolve the vector into components as $A = A' + A_z$ and then $A' = A_x + A_y$.

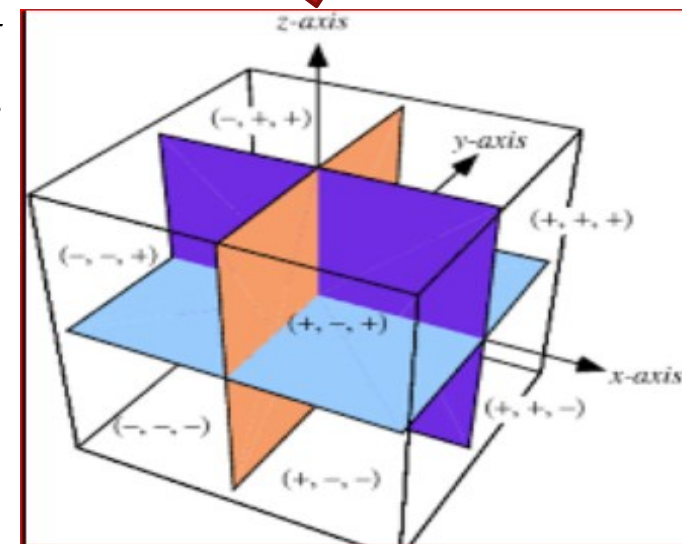
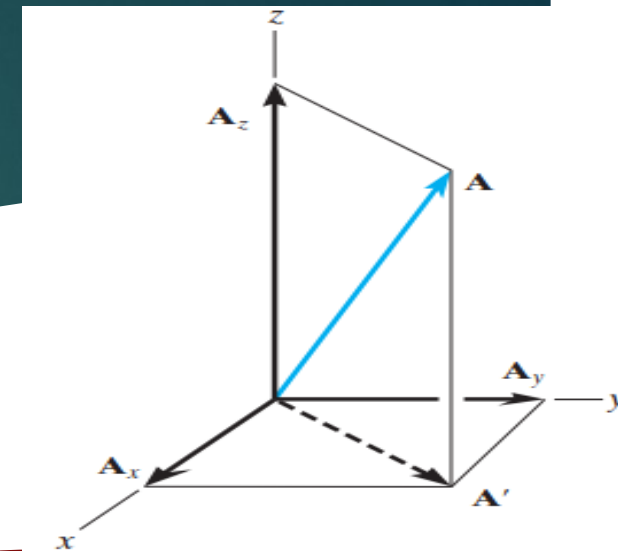

FORCE VECTORS IN SPACE (3D)

CARTESIAN VECTORS

Rectangular Components of a Vector

- ▶ *Combining these equations, to eliminate A' , A is represented by the vector sum of its three rectangular components*

$$A = A_x + A_y + A_z$$

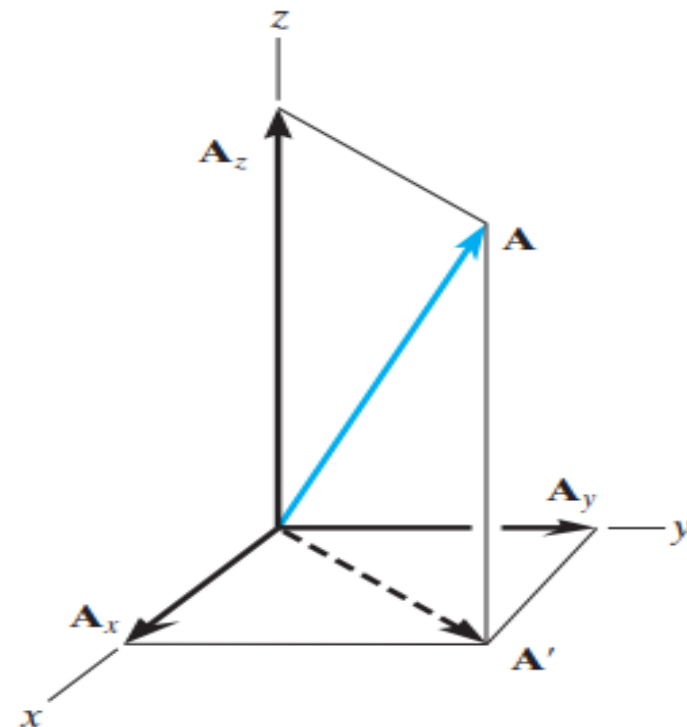

FORCE VECTORS IN SPACE (3D)

CARTESIAN VECTORS

Cartesian Unit Vectors

- ▶ In 3D the set of Cartesian unit vectors, \mathbf{i} , \mathbf{j} , \mathbf{k} , is used to designate the directions of the x , y , z axes, respectively.
- ▶ As discussed, the sense (or arrowhead) of these vectors will be represented analytically by a plus or minus sign, depending on whether they are directed along the positive or negative x , y , or z axes

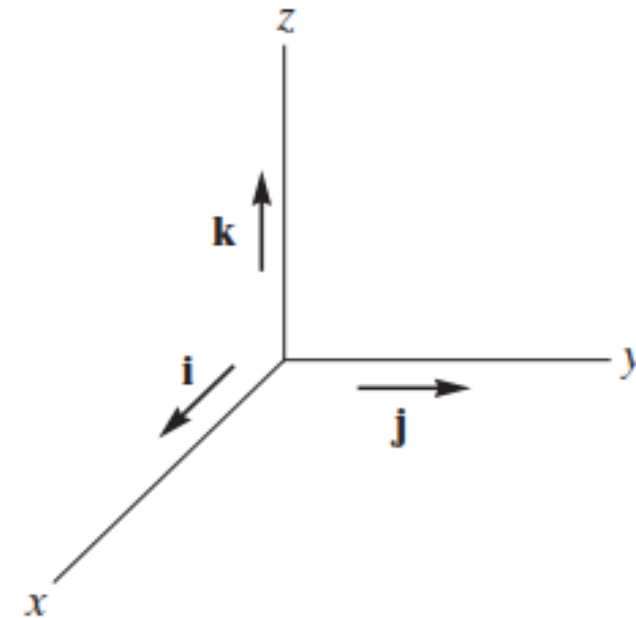

FORCE VECTORS IN SPACE (3D)

CARTESIAN VECTORS

Cartesian Vectors Representation

- ▶ Since the three components of A in Eq. $A = A_x + A_y + A_z$ act in the positive \mathbf{i} , \mathbf{j} , and \mathbf{k} directions, we can write A in Cartesian vector form as

$$A = A_x\mathbf{i} + A_y\mathbf{j} + A_z\mathbf{k}$$

- ▶ There is a distinct advantage to writing vectors in this manner as separating the magnitude and direction of each component vector will simplify the operations of vector algebra, particularly in three dimensions

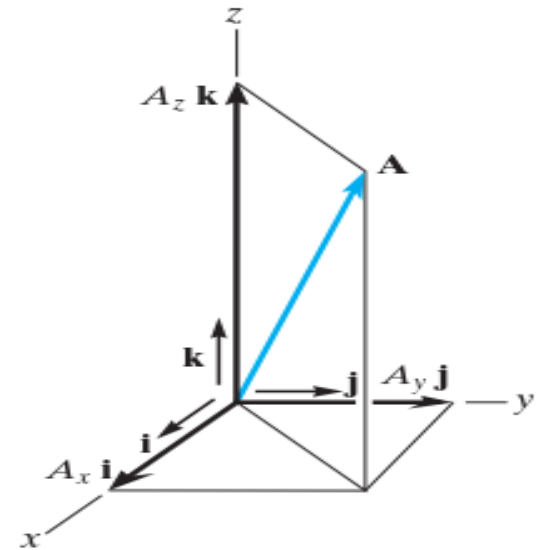

FORCE VECTORS IN SPACE (3D)

CARTESIAN VECTORS

Magnitude of Cartesian Vectors

- ▶ It is always possible to obtain the magnitude of A provided it is expressed in Cartesian vector form.
- ▶ As shown from the blue right triangle, $A = \sqrt{A'^2 + A_z^2}$ and from the gray right triangle, $A' = \sqrt{A_y^2 + A_x^2}$
- ▶ Combining these equations to eliminate A' yields

$$A = \sqrt{A_x^2 + A_y^2 + A_z^2}$$

- ▶ Therefore the magnitude of A is equal to the positive square root of the sum of the squares of its components

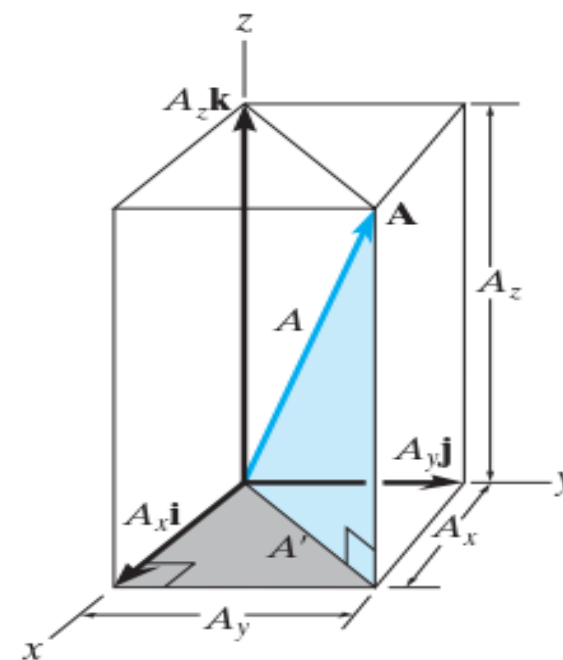

FORCE VECTORS IN SPACE (3D)

CARTESIAN VECTORS

Direction of Cartesian Vectors

- ▶ We will define the direction of A by the coordinate direction angles α (alpha), β (beta), and γ (gamma), measured between the tail of A and the positive x , y , z axes provided they are located at the tail of A
- ▶ Note that regardless of where A is directed, each of these angles will be between 0° and 180°
- ▶ To determine α , β and γ , consider the projection of A onto the x , y , z axes

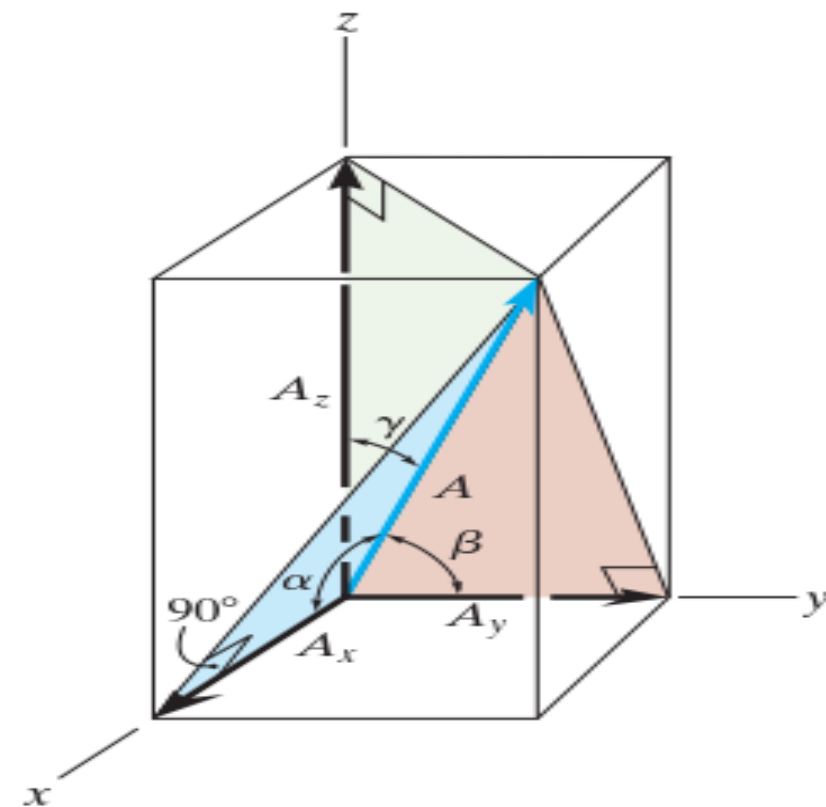

FORCE VECTORS IN SPACE (3D)

CARTESIAN VECTORS

Direction of Cartesian Vectors

- ▶ Referring to the colored right triangles shown in the figure, we have

$$\cos \alpha = \frac{A_x}{A} \quad \cos \beta = \frac{A_y}{A} \quad \cos \gamma = \frac{A_z}{A}$$

- ▶ These numbers are known as the *direction cosines of A*
- ▶ Once they have been obtained, the coordinate direction angles α , β and γ can then be determined from the inverse cosines

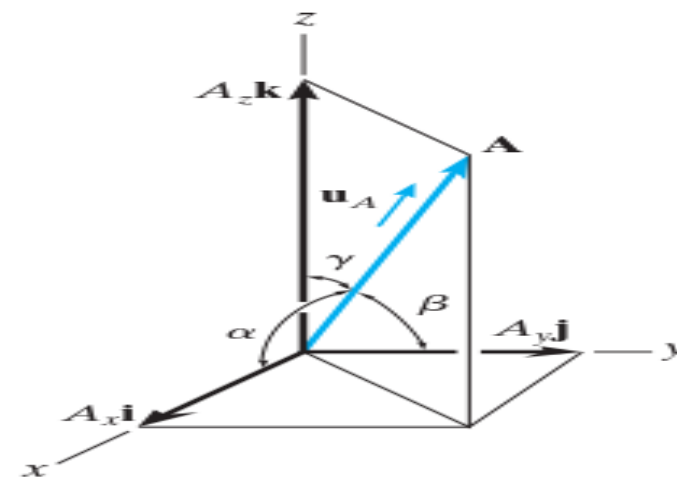
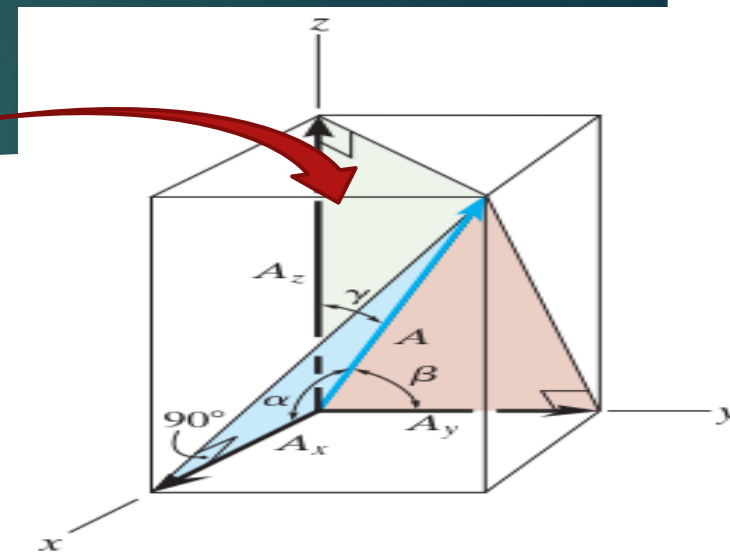

FORCE VECTORS IN SPACE (3D)

CARTESIAN VECTORS

Direction of Cartesian Vectors

► An easy way of obtaining these direction cosines is to form a unit vector \mathbf{u}_A in the direction of A

► If A is expressed in Cartesian vector form,

$$\mathbf{A} = A_x \mathbf{i} + A_y \mathbf{j} + A_z \mathbf{k},$$

► then \mathbf{u}_A will have a magnitude of one and be dimensionless provided A is divided by its magnitude, i.e.,

$$\mathbf{u}_A = \frac{\mathbf{A}}{A} = \frac{A_x}{A} \mathbf{i} + \frac{A_y}{A} \mathbf{j} + \frac{A_z}{A} \mathbf{k}$$

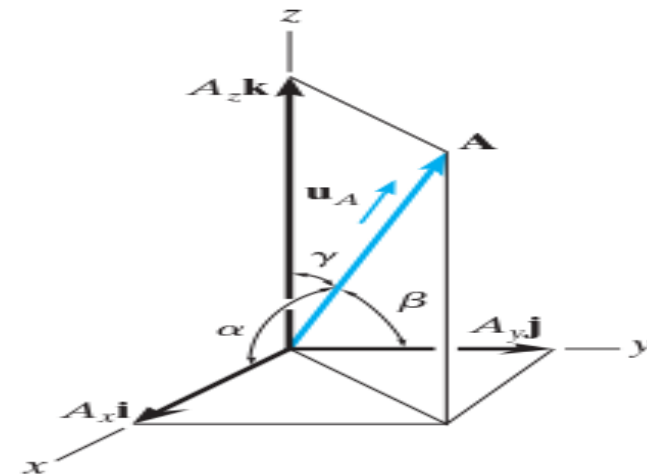

FORCE VECTORS IN SPACE (3D)

CARTESIAN VECTORS

$$\mathbf{u}_A = \frac{\mathbf{A}}{A} = \frac{A_x}{A} \mathbf{i} + \frac{A_y}{A} \mathbf{j} + \frac{A_z}{A} \mathbf{k}$$

Direction of Cartesian Vectors

► We know that

$$A = \sqrt{A_x^2 + A_y^2 + A_z^2}$$

► By comparison with

$$\cos \alpha = \frac{A_x}{A} \quad \cos \beta = \frac{A_y}{A} \quad \cos \gamma = \frac{A_z}{A}$$

► It is seen that the \mathbf{i} , \mathbf{j} , \mathbf{k} components of \mathbf{u}_A represent the direction cosines of A , i.e., $\mathbf{u}_A = \cos \alpha \mathbf{i} + \cos \beta \mathbf{j} + \cos \gamma \mathbf{k}$

► Since the magnitude of a vector is equal to the positive square root of the sum of the squares of the magnitudes of its components, and \mathbf{u}_A has a magnitude of one, then from the above equation an important relation among the direction cosines can be formulated as, i.e

$$\cos^2 \alpha + \cos^2 \beta + \cos^2 \gamma = 1$$

CARTESIAN VECTORS

$$\cos \alpha = \frac{A_x}{A} \quad \cos \beta = \frac{A_y}{A} \quad \cos \gamma = \frac{A_z}{A}$$

$$\cos^2 \alpha + \cos^2 \beta + \cos^2 \gamma = 1$$

Direction of Cartesian Vectors

- ▶ Here we can see that if only two of the coordinate angles are known, the third angle can be found using this equation
- ▶ Finally, if the magnitude and coordinate direction angles of A are known, then A may be expressed in Cartesian vector form as

$$\begin{aligned} \mathbf{A} &= A \mathbf{u}_A \\ &= A \cos \alpha \mathbf{i} + A \cos \beta \mathbf{j} + A \cos \gamma \mathbf{k} \\ &= A_x \mathbf{i} + A_y \mathbf{j} + A_z \mathbf{k} \end{aligned}$$

FORCE VECTORS IN SPACE (3D)

CARTESIAN VECTORS

Addition & Subtraction Cartesian Vectors

- ▶ The addition (or subtraction) of two or more vectors is greatly simplified if the vectors are expressed in terms of their Cartesian components.
- ▶ For example, if $A = A_x\mathbf{i} + A_y\mathbf{j} + A_z\mathbf{k}$ and

$$B = B_x\mathbf{i} + B_y\mathbf{j} + B_z\mathbf{k}$$
- ▶ then the resultant vector, R , has components which are the scalar sums of the \mathbf{i} , \mathbf{j} , \mathbf{k} components of A and B , i.e.,
- ▶ $R = A + B = (A_x + B_x)\mathbf{i} + (A_y + B_y)\mathbf{j} + (A_z + B_z)\mathbf{k}$

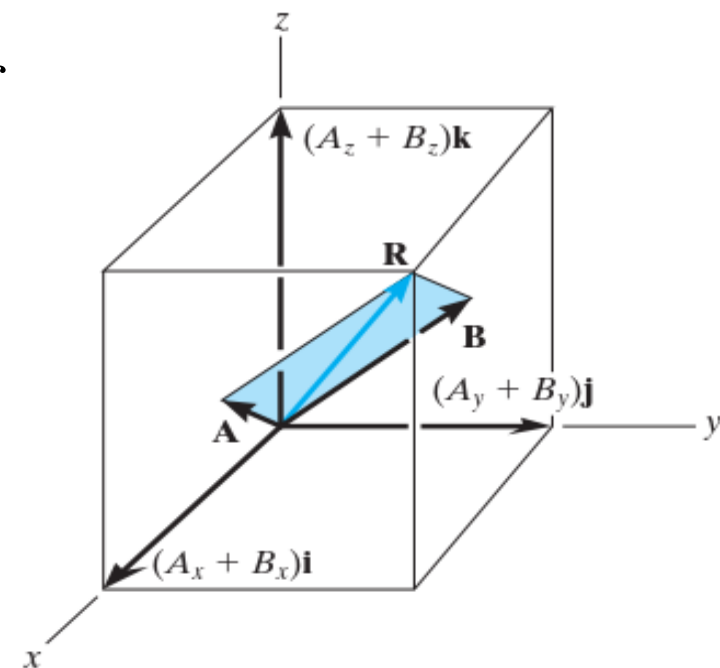

FORCE VECTORS IN SPACE (3D)

CARTESIAN VECTORS

Addition & Subtraction Cartesian Vectors

- ▶ $R = A - B = (A_x - B_x)\mathbf{i} + (A_y - B_y)\mathbf{j} + (A_z - B_z)\mathbf{k}$
- ▶ *If this is generalized and applied to a system of several concurrent forces, then the force resultant is the vector sum of all the forces in the system and can be written as*

$$\mathbf{F}_R = \sum \mathbf{F} = \sum F_x \mathbf{i} + \sum F_y \mathbf{j} + \sum F_z \mathbf{k}$$

- ▶ *Where $\sum F_x$, $\sum F_y$, and $\sum F_z$ represent the algebraic sums of the respective x , y , z or \mathbf{i} , \mathbf{j} , \mathbf{k} components of each force in the system*

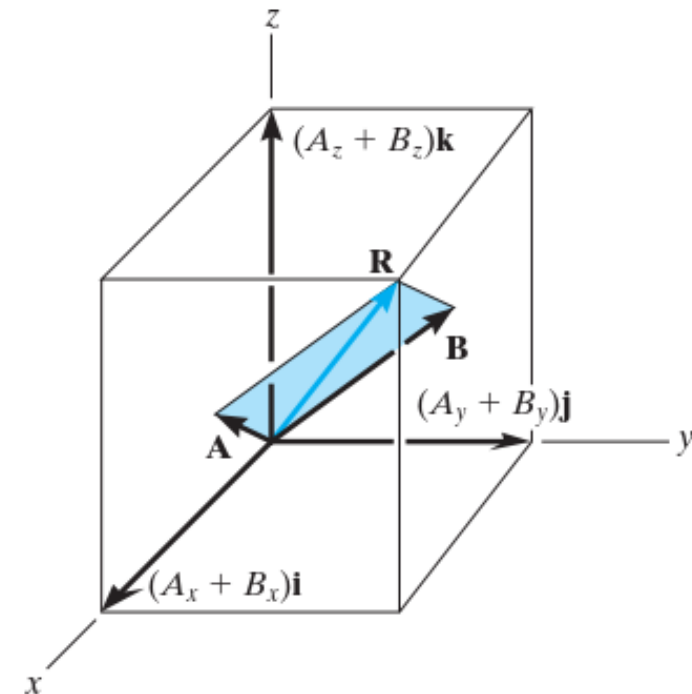

FORCE VECTORS IN SPACE (3D)

CARTESIAN VECTORS

Important Points

- A Cartesian vector \mathbf{A} has $\mathbf{i}, \mathbf{j}, \mathbf{k}$ components along the x, y, z axes. If \mathbf{A} is known, its magnitude is defined by $A = \sqrt{A_x^2 + A_y^2 + A_z^2}$.
- The direction of a Cartesian vector can be defined by the three angles α, β, γ , measured from the *positive* x, y, z axes to the *tail* of the vector. To find these angles formulate a unit vector in the direction of \mathbf{A} , i.e., $\mathbf{u}_A = \mathbf{A}/A$, and determine the inverse cosines of its components. Only two of these angles are independent of one another; the third angle is found from $\cos^2 \alpha + \cos^2 \beta + \cos^2 \gamma = 1$.

FORCE VECTORS IN SPACE (3D)

EXAMPLES 2-4*Question*

- Determine the magnitude and the coordinate direction angles of the resultant force acting on the ring in Fig. below

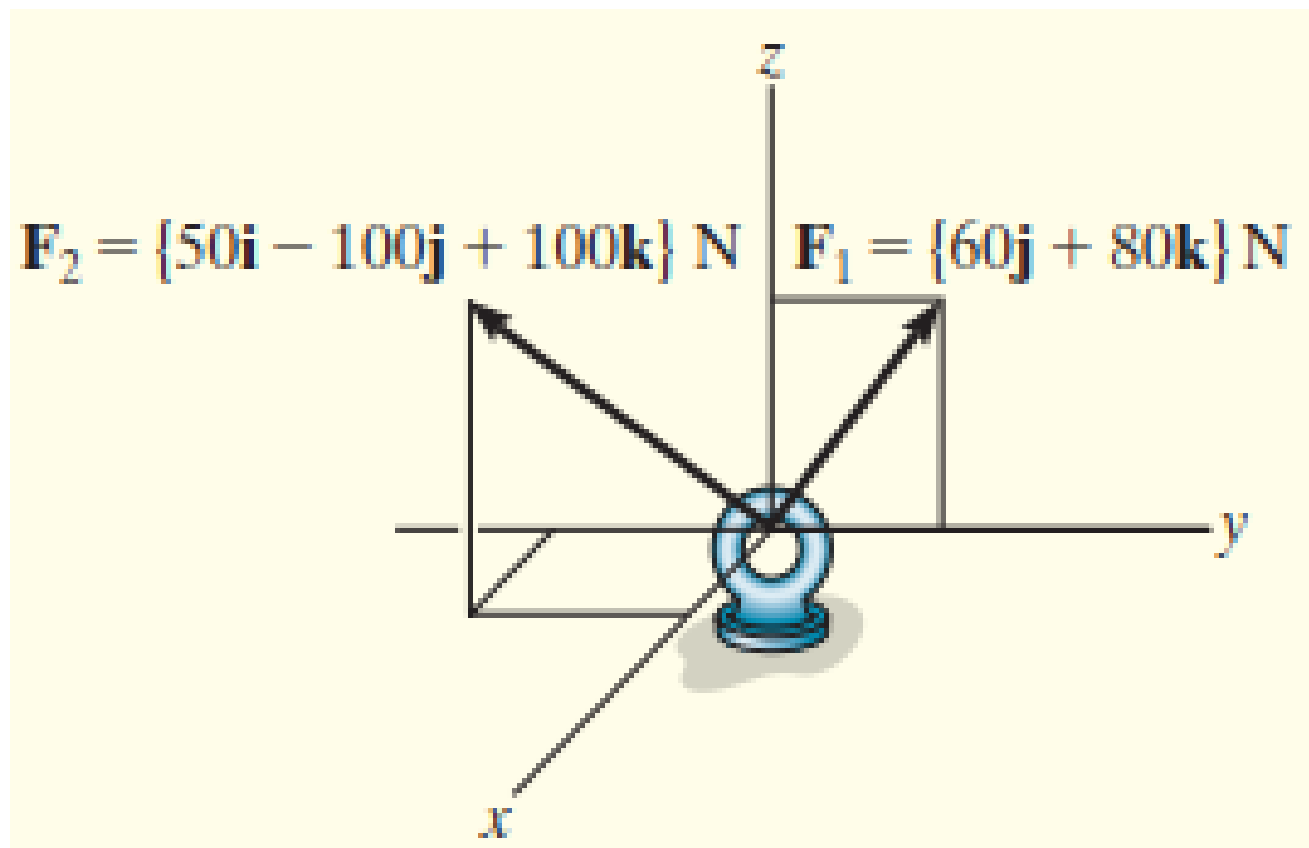

FORCE VECTORS IN SPACE (3D)

EXAMPLES 2-4

$$\mathbf{u}_A = \frac{\mathbf{A}}{A} = \frac{A_x}{A}\mathbf{i} + \frac{A_y}{A}\mathbf{j} + \frac{A_z}{A}\mathbf{k}$$

SOLUTION

- ▶ *Since each force is represented in Cartesian vector form, the resultant force is calculated as follows*
- ▶ $F_R = \Sigma F = F_1 + F_2 = \{0\mathbf{i} + 60\mathbf{j} + 80\mathbf{k}\}N + \{50\mathbf{i} - 100\mathbf{j} + 100\mathbf{k}\}N$
- ▶ $F_R = \{50\mathbf{i} - 40\mathbf{j} + 180\mathbf{k}\}N$ then the magnitude of F_R is
- ▶ $F_R = \sqrt{F_{Rx}^2 + F_{Ry}^2 + F_{Rz}^2} = \{\sqrt{50^2 + (-40)^2 + 180^2}\}N = 191.0N$
- ▶ *The coordinate direction angles α , β , γ are determined from the components of the unit vector acting in the direction of F_R*

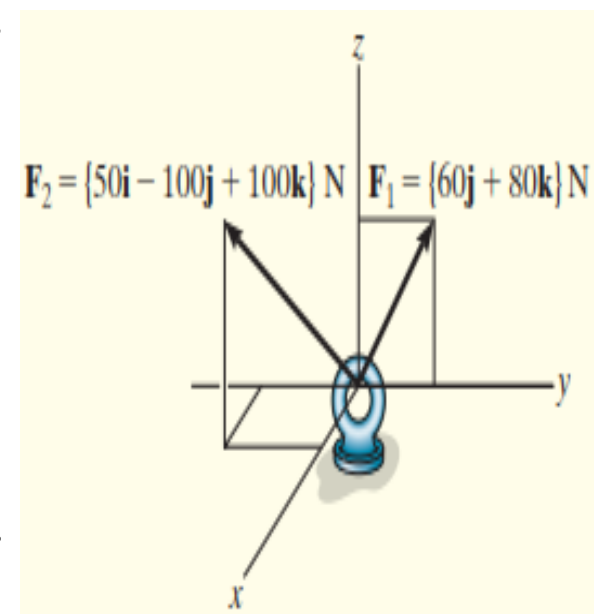

$$\mathbf{u}_{F_R} = \frac{\mathbf{F}_R}{F_R} = \frac{50}{191.0}\mathbf{i} - \frac{40}{191.0}\mathbf{j} + \frac{180}{191.0}\mathbf{k} = 0.2617\mathbf{i} - 0.2094\mathbf{j} + 0.9422\mathbf{k}$$

FORCE VECTORS IN SPACE (3D)

$$\mathbf{u}_A = \frac{\mathbf{A}}{A} = \frac{A_x}{A}\mathbf{i} + \frac{A_y}{A}\mathbf{j} + \frac{A_z}{A}\mathbf{k}$$

EXAMPLES 2-4

$$\cos \alpha = \frac{A_x}{A} \quad \cos \beta = \frac{A_y}{A} \quad \cos \gamma = \frac{A_z}{A}$$

SOLUTION

$$\mathbf{u}_{F_R} = \frac{\mathbf{F}_R}{F_R} = \frac{50}{191.0}\mathbf{i} - \frac{40}{191.0}\mathbf{j} + \frac{180}{191.0}\mathbf{k}$$

$$= 0.2617\mathbf{i} - 0.2094\mathbf{j} + 0.9422\mathbf{k}$$

$$\cos \alpha = 0.2617 \quad \alpha = 74.8^\circ$$

$$\cos \beta = -0.2094 \quad \beta = 102^\circ$$

$$\cos \gamma = 0.9422 \quad \gamma = 19.6^\circ$$

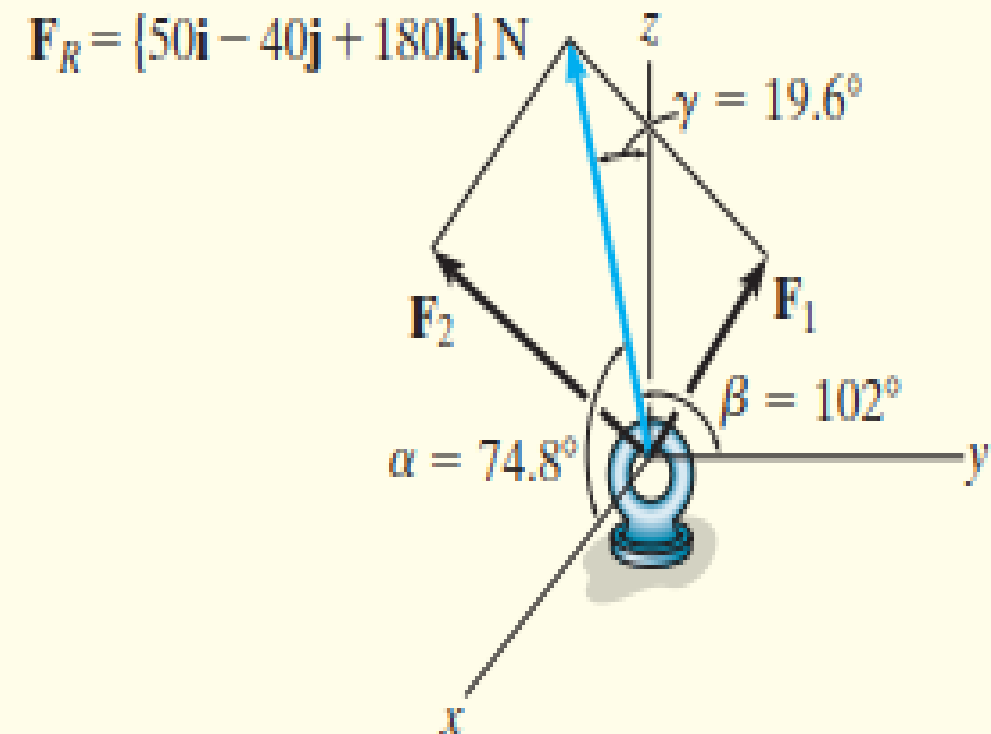

FORCE VECTORS IN SPACE (3D)

EXAMPLES 2-5QUESTION for THINKING

- Express the force F shown in the Fig. as a Cartesian vector and find the directional angles α , β and γ .

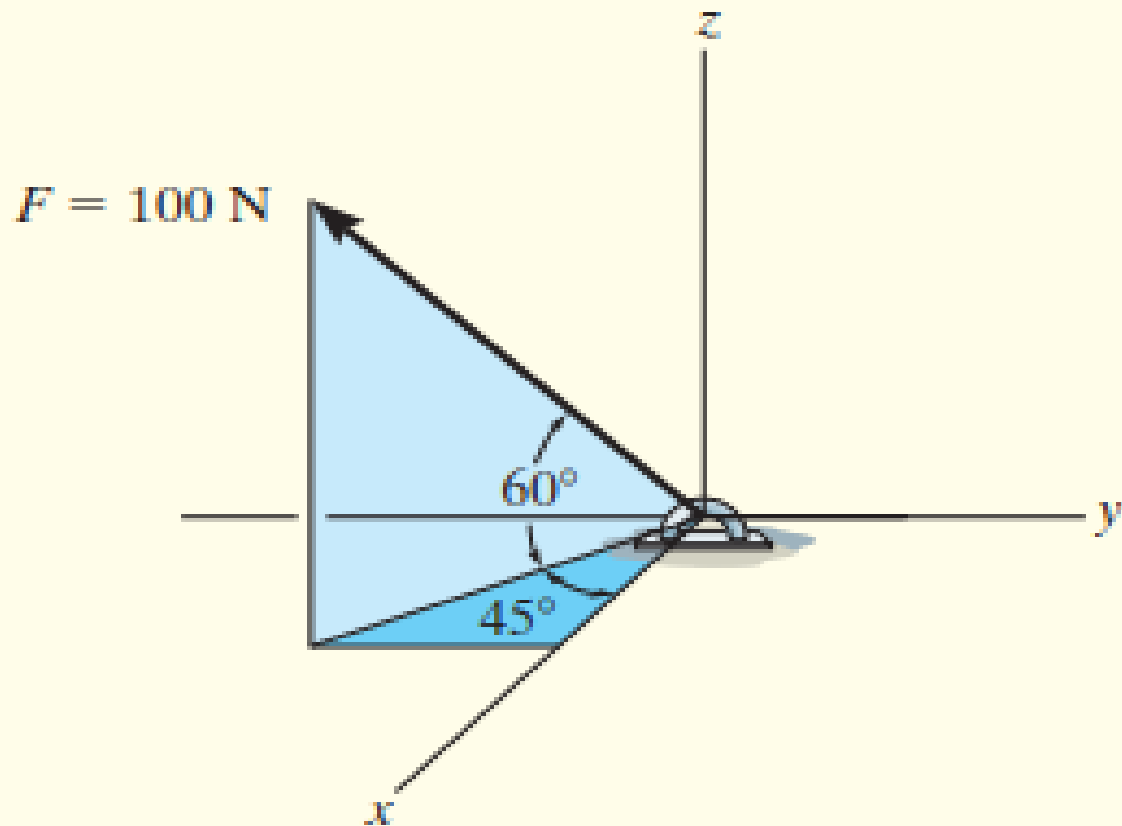

FORCE VECTORS IN SPACE (3D)

55

EXAMPLES 2-5

$$\cos \alpha = \frac{A_x}{A} \quad \cos \beta = \frac{A_y}{A} \quad \cos \gamma = \frac{A_z}{A}$$

$$\mathbf{u}_A = \frac{\mathbf{A}}{A} = \frac{A_x}{A} \mathbf{i} + \frac{A_y}{A} \mathbf{j} + \frac{A_z}{A} \mathbf{k}$$

SOLUTION

► Which formulas are necessary for this problem?

$$\mathbf{F}_R = \Sigma \mathbf{F} = \Sigma F_x \mathbf{i} + \Sigma F_y \mathbf{j} + \Sigma F_z \mathbf{k}$$

parallelogram law by resolution
of forces in the x,y&z components
 $A = A_x + A_y + A_z$

$$\cos^2 \alpha + \cos^2 \beta + \cos^2 \gamma = 1$$

$$A = \sqrt{A_x^2 + A_y^2 + A_z^2}$$

SOHCAHTOA/Trigonometry

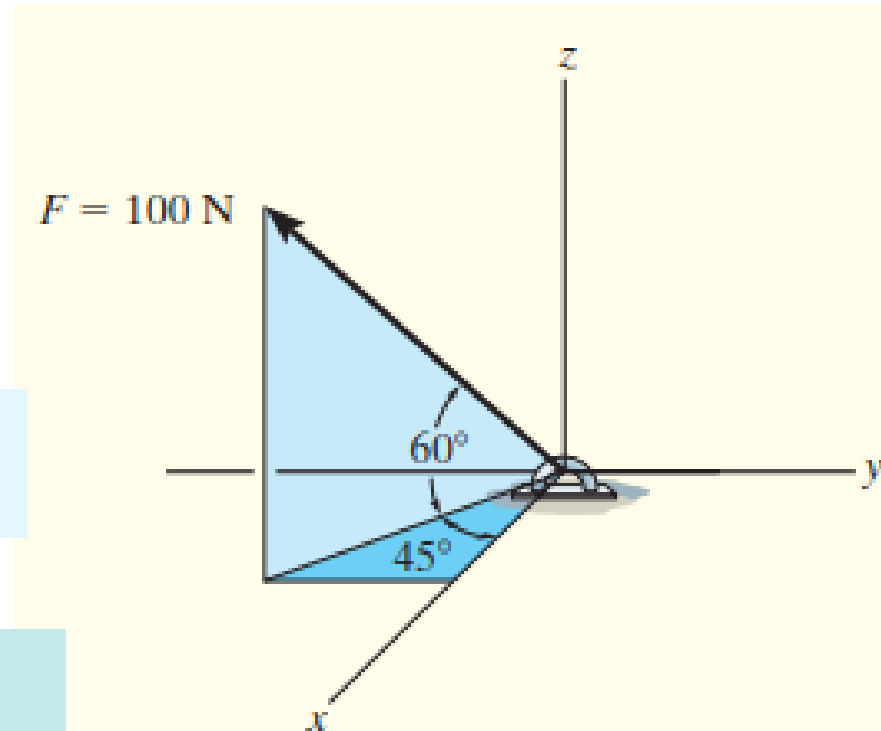

EXAMPLES 2-5

SOHCAHTOA

*Parallelogram law by resolution of forces in the x, y & z components
 $A = A' + Az$ and $A' = Ax + Ay$*

SOLUTION

- ▶ Note that the angles of 60° and 45° defining the direction of F are not coordinate direction angles.
- ▶ Two successive applications of the parallelogram law are needed to resolve F into its x , y , z components. First $F = F' + Fz$, then $F' = Fx + Fy$. By trigonometry, the magnitudes of the components are

$$F_z = 100 \sin 60^\circ \text{ N} = 86.60 \text{ N}$$

$$F' = 100 \cos 60^\circ \text{ N} = 50 \text{ N}$$

$$F_x = F' \cos 45^\circ = 50 \cos 45^\circ \text{ N} = 35.36 \text{ N}$$

$$F_y = F' \sin 45^\circ = 50 \sin 45^\circ \text{ N} = 35.36 \text{ N}$$

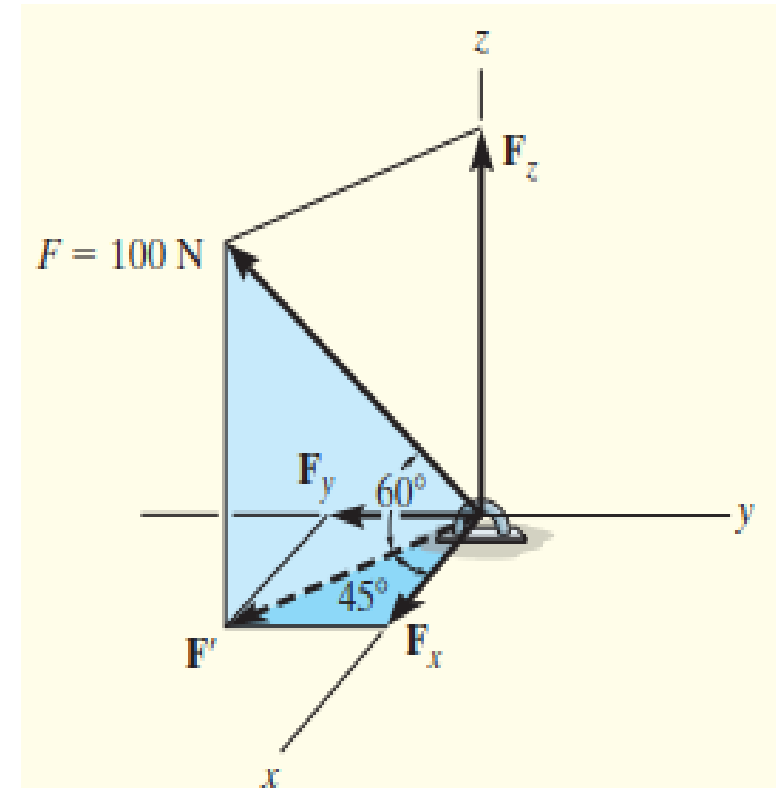

FORCE VECTORS IN SPACE (3D)

57

EXAMPLES 2-5

$$A = \sqrt{A_x^2 + A_y^2 + A_z^2}$$

SOLUTION

► Realizing that F_y is in the $-j$ direction, we have the answer as $\longrightarrow F = \{35.36i - 35.36j + 86.60k\}$

► To check that the answer is correct, (magnitude of this vector is indeed 100N), we apply eqn below

$$F = \sqrt{F_x^2 + F_y^2 + F_z^2}$$

$$= \sqrt{35.36^2 + 35.36^2 + 86.60^2} = 100 \text{ N}$$

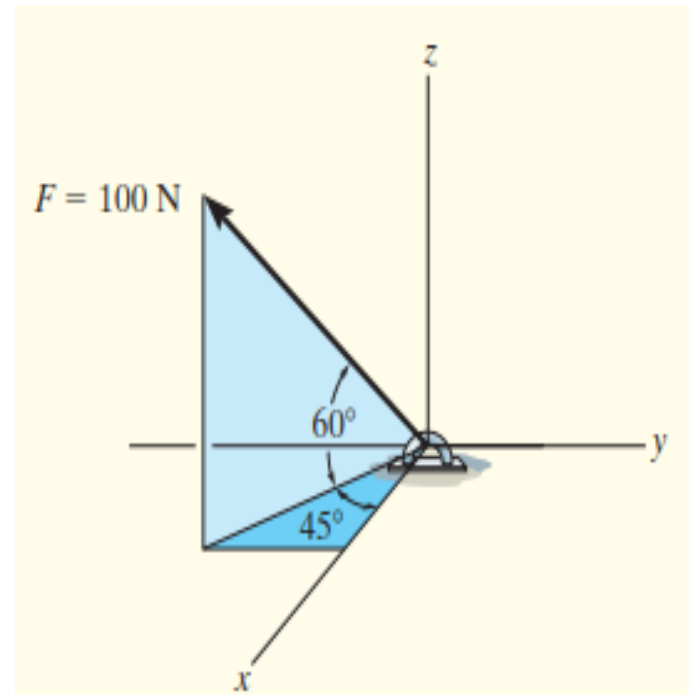

FORCE VECTORS IN SPACE (3D)

58

$$\cos \alpha = \frac{A_x}{A} \quad \cos \beta = \frac{A_y}{A} \quad \cos \gamma = \frac{A_z}{A}$$

EXAMPLES 2-5

$$\mathbf{u}_A = \frac{\mathbf{A}}{A} = \frac{A_x}{A} \mathbf{i} + \frac{A_y}{A} \mathbf{j} + \frac{A_z}{A} \mathbf{k}$$

SOLUTION

- The coordinate direction angles of F can be determined from the components of the unit vector acting in the direction of F

$$\mathbf{u} = \frac{\mathbf{F}}{F} = \frac{F_x}{F} \mathbf{i} + \frac{F_y}{F} \mathbf{j} + \frac{F_z}{F} \mathbf{k} = \frac{35.36}{100} \mathbf{i} - \frac{35.36}{100} \mathbf{j} + \frac{86.60}{100} \mathbf{k}$$

$$= 0.3536 \mathbf{i} - 0.3536 \mathbf{j} + 0.8660 \mathbf{k}$$

$$\alpha = \cos^{-1}(0.3536) = 69.3^\circ$$

$$\beta = \cos^{-1}(-0.3536) = 111^\circ$$

$$\gamma = \cos^{-1}(0.8660) = 30.0^\circ$$

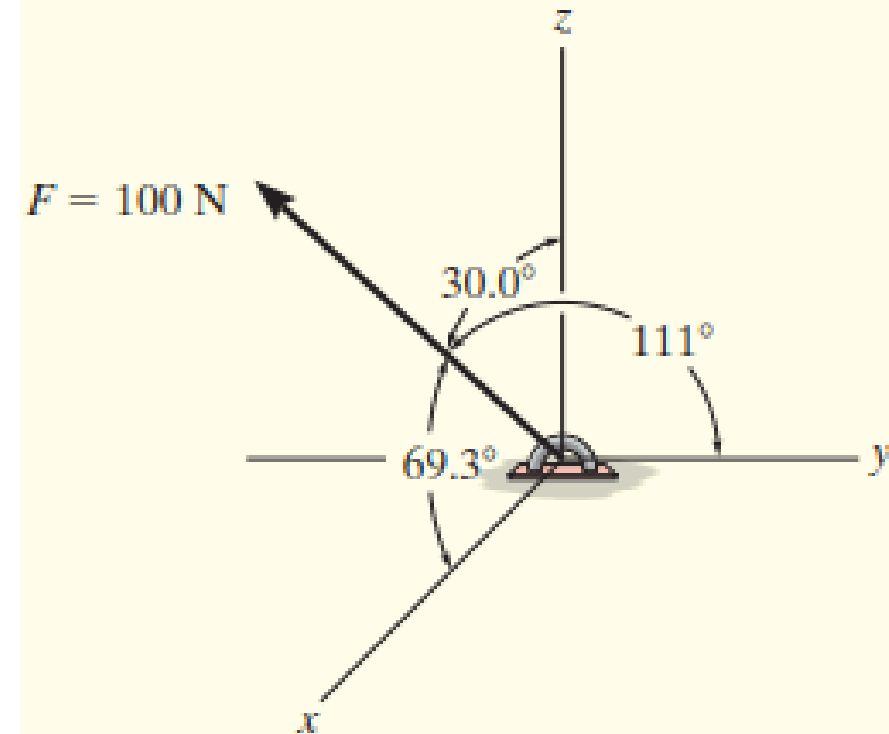

FORCE VECTORS IN SPACE (3D)

EXAMPLES 2-6*QUESTION for HOMEWORK*

- Two forces act on the hook shown in Fig. Specify the magnitude of F_2 and its coordinate direction angles so that the resultant force F_R acts along the positive y axis and has a magnitude of 800N

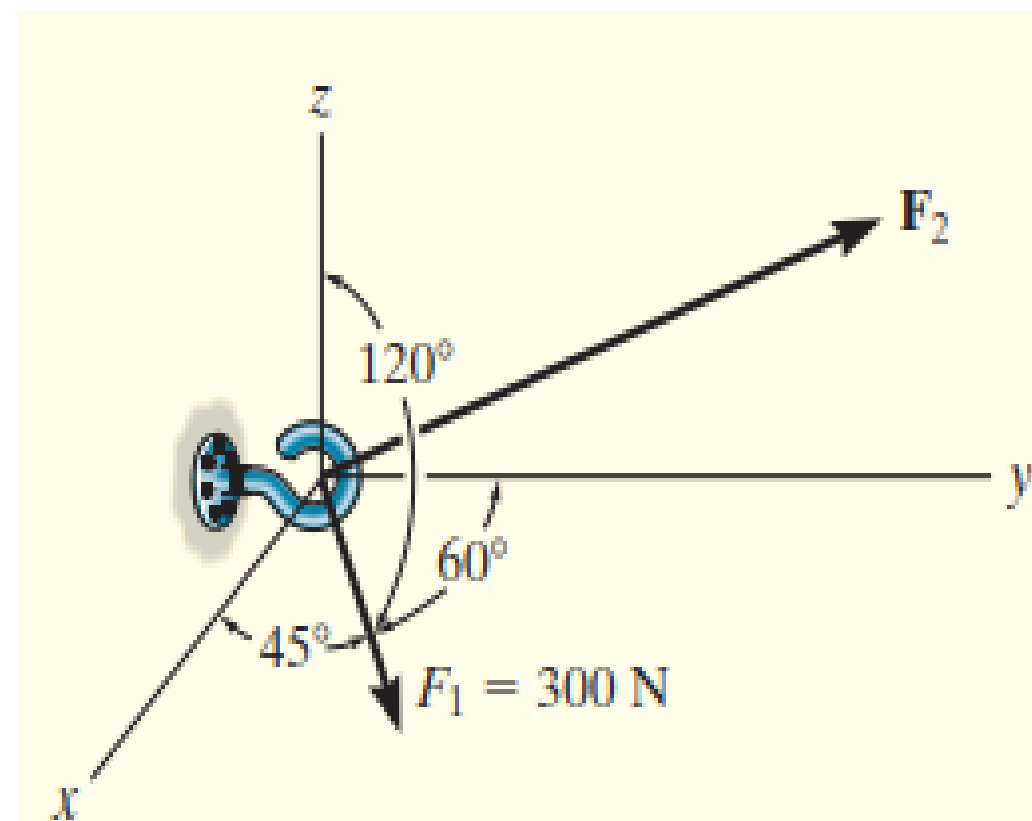

EXAMPLES 2-6

$$\begin{aligned} \mathbf{A} &= A \mathbf{u}_A \\ &= A \cos \alpha \mathbf{i} + A \cos \beta \mathbf{j} + A \cos \gamma \mathbf{k} \\ &= A_x \mathbf{i} + A_y \mathbf{j} + A_z \mathbf{k} \end{aligned}$$

SOLUTION

► To solve this problem, the resultant force F_R and its two components, F_1 and F_2 , will each be expressed in Cartesian vector form.

► As shown in Fig, it is required that $F_R = F_1 + F_2$.

► Applying Eq.

$$\begin{aligned} \mathbf{F}_1 &= F_1 \cos \alpha_1 \mathbf{i} + F_1 \cos \beta_1 \mathbf{j} + F_1 \cos \gamma_1 \mathbf{k} \\ &= 300 \cos 45^\circ \mathbf{i} + 300 \cos 60^\circ \mathbf{j} + 300 \cos 120^\circ \mathbf{k} \\ &= \{212.1\mathbf{i} + 150\mathbf{j} - 150\mathbf{k}\} \text{ N} \\ \mathbf{F}_2 &= F_{2x} \mathbf{i} + F_{2y} \mathbf{j} + F_{2z} \mathbf{k} \end{aligned}$$

► Since F_R has a magnitude of 800 N and acts in the $+j$ direction, $F_R = (800 \text{ N})(+j) = \{800j\} \text{ N}$

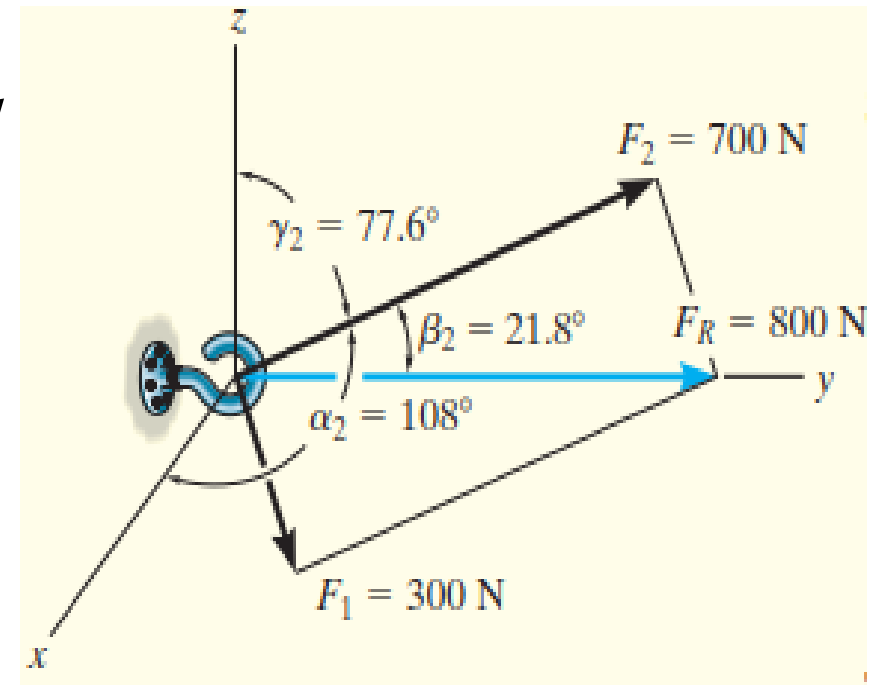

FORCE VECTORS IN SPACE (3D)

$$\cos \alpha = \frac{A_x}{A} \quad \cos \beta = \frac{A_y}{A} \quad \cos \gamma = \frac{A_z}{A}$$

EXAMPLES 2-6

SOLUTION

► We require

$$\mathbf{F}_R = \mathbf{F}_1 + \mathbf{F}_2$$

$$800\mathbf{j} = 212.1\mathbf{i} + 150\mathbf{j} - 150\mathbf{k} + F_{2x}\mathbf{i} + F_{2y}\mathbf{j} + F_{2z}\mathbf{k}$$

$$800\mathbf{j} = (212.1 + F_{2x})\mathbf{i} + (150 + F_{2y})\mathbf{j} + (-150 + F_{2z})\mathbf{k}$$

► To satisfy this equation the *i*, *j*, *k* components of F_R must be equal to the corresponding *i*, *j*, *k* components of $(F_1 + F_2)$
Hence,

$$\begin{aligned} 0 &= 212.1 + F_{2x} & F_{2x} &= -212.1 \text{ N} \\ 800 &= 150 + F_{2y} & F_{2y} &= 650 \text{ N} \\ 0 &= -150 + F_{2z} & F_{2z} &= 150 \text{ N} \end{aligned}$$

► The magnitude of F_2 is thus

$$F_2 = \sqrt{(-212.1 \text{ N})^2 + (650 \text{ N})^2 + (150 \text{ N})^2}$$

$$= 700 \text{ N}$$

► We can use Eq. to determine $\alpha_2, \beta_2, \gamma_2$.

$$\cos \alpha_2 = \frac{-212.1}{700}; \quad \alpha_2 = 108^\circ$$

$$\cos \beta_2 = \frac{650}{700}; \quad \beta_2 = 21.8^\circ$$

$$\cos \gamma_2 = \frac{150}{700}; \quad \gamma_2 = 77.6^\circ$$

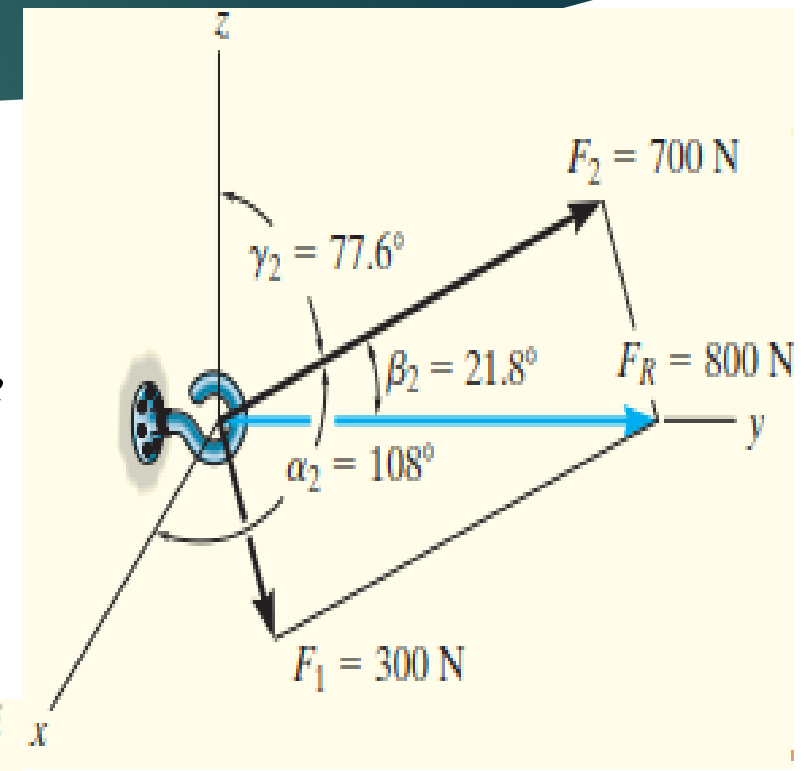

FORCE VECTORS IN SPACE (3D)

POSITION VECTORS

- ▶ You will appreciate that the position vector is of importance in formulating a Cartesian force vector directed between two points in space
- ▶ Later in the course you will use the position vector to calculate moment of force

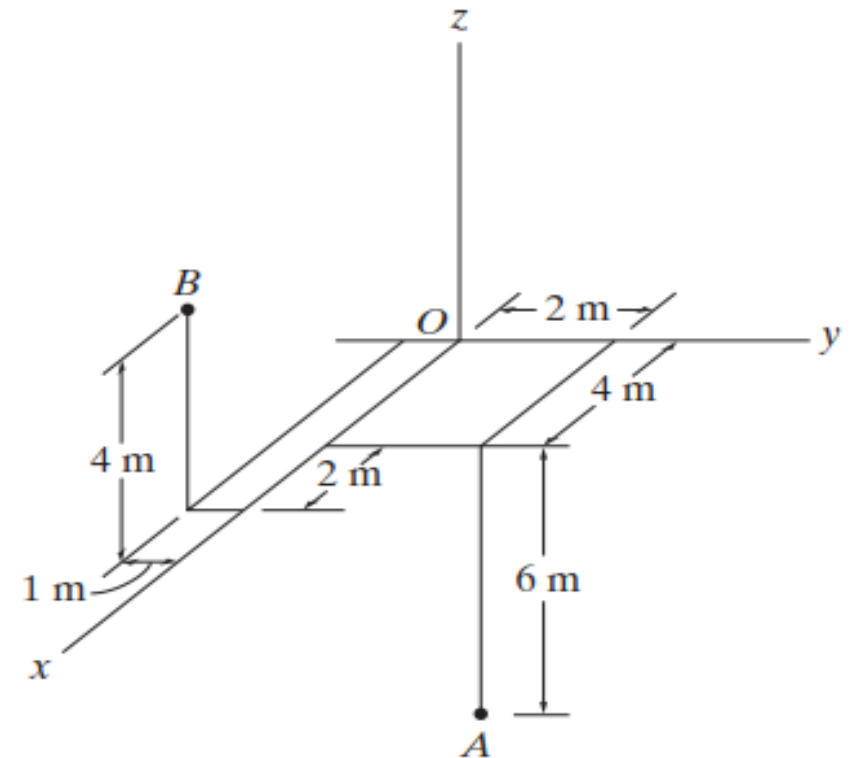

FORCE VECTORS IN SPACE (3D)

POSITION VECTORS

x, y, z Coordinates

- ▶ *Throughout the course we will use a right-handed coordinate system to reference the location of points in space.*
- ▶ *The positive z axis to be directed upward so that it measures the height of an object or the altitude of a point.*
- ▶ *The x, y axes then lie in the horizontal plane,*
- ▶ *Points in space are located relative to the origin of coordinates, O,*

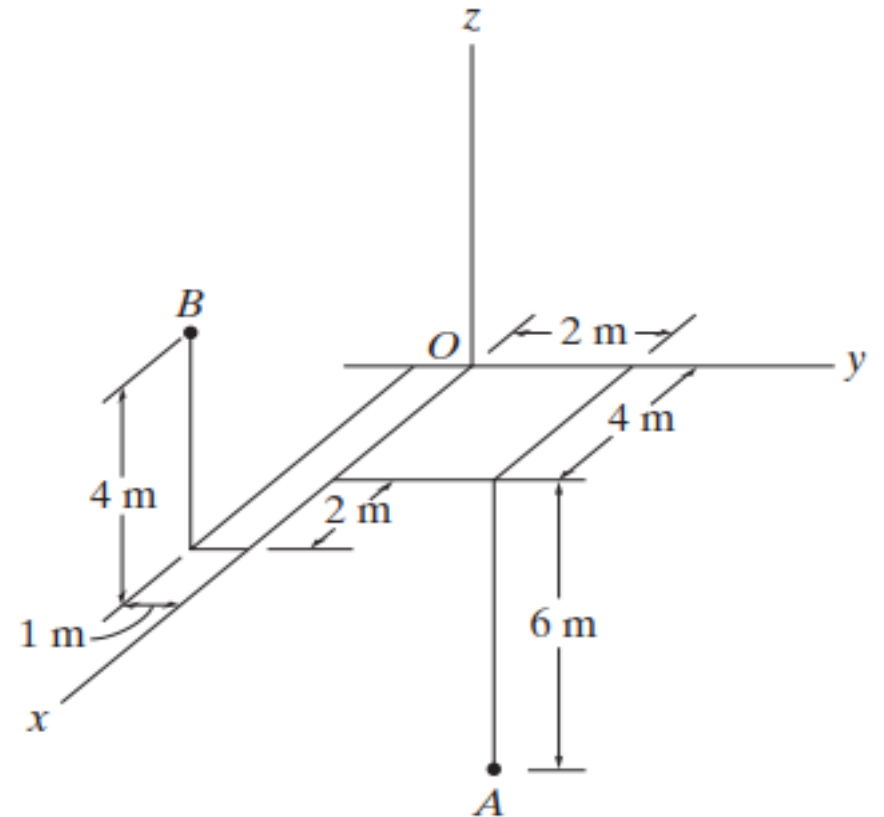

FORCE VECTORS IN SPACE (3D)

POSITION VECTORS

- ▶ A position vector \mathbf{r} is defined as a fixed vector which locates a point in space relative to another point
- ▶ For example, if \mathbf{r} extends from the origin of coordinates, O , to point $P(x, y, z)$
- ▶ then \mathbf{r} can be expressed in Cartesian vector form as
$$\mathbf{r} = x\mathbf{i} + y\mathbf{j} + z\mathbf{k}$$

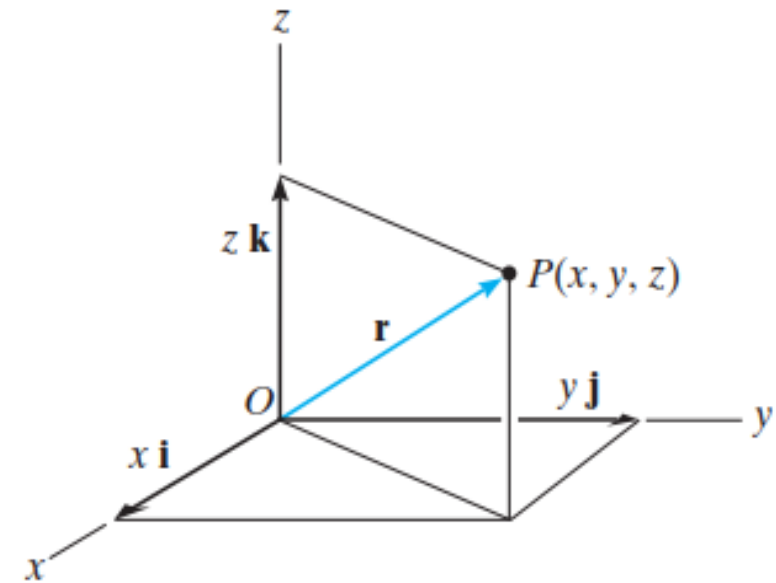

FORCE VECTORS IN SPACE (3D)

POSITION VECTORS

- ▶ $\mathbf{r} = x\mathbf{i} + y\mathbf{j} + z\mathbf{k}$
- ▶ Note how the head-to-tail vector addition of the three components yields vector \mathbf{r} ,
- ▶ Starting at the origin O , one “travels” x in the $+\mathbf{i}$ direction, then y in the $+\mathbf{j}$ direction, and finally z in the $+\mathbf{k}$ direction to arrive at point $P(x, y, z)$.

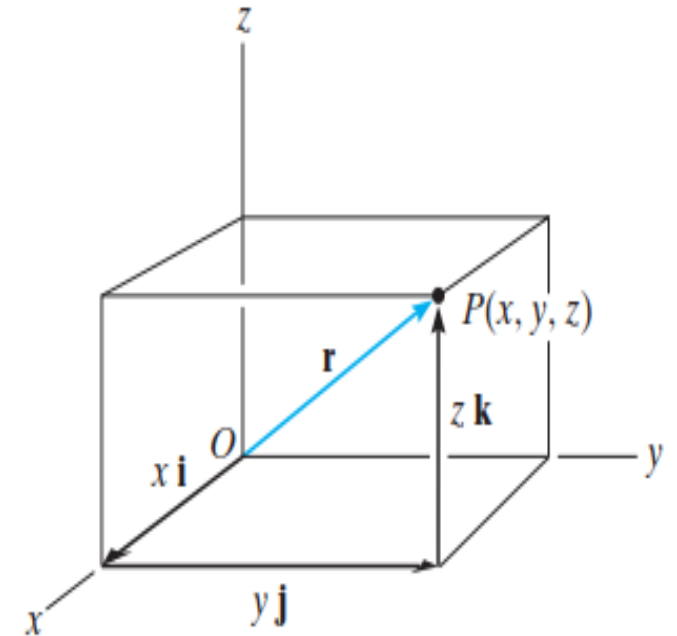

FORCE VECTORS IN SPACE (3D)

POSITION VECTORS

- ▶ *In other cases, the position vector may be directed from point A to point B in space*
- ▶ *This vector is also designated by the symbol \mathbf{r}*
- ▶ *As a matter of convention, we will sometimes refer to this vector with two subscripts to indicate from and to the point where it is directed. Thus, r can also be designated as \mathbf{r}_{AB}*

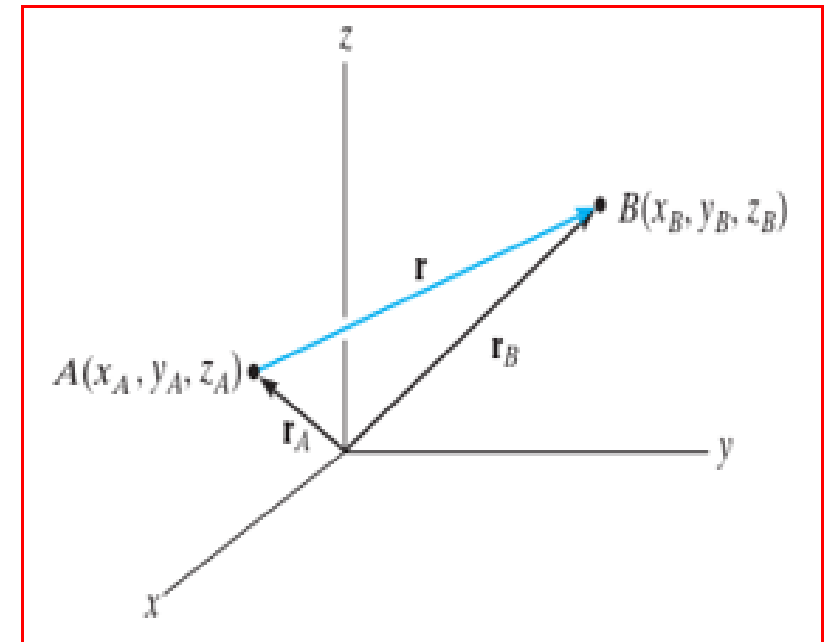

FORCE VECTORS IN SPACE (3D)

POSITION VECTORS

- ▶ From Fig. shown, by the head-to-tail vector addition, using the triangle rule, we require

$$\mathbf{r}_A + \mathbf{r} = \mathbf{r}_B$$

- ▶ Solving for \mathbf{r} and expressing \mathbf{r}_A and \mathbf{r}_B in Cartesian vector form yields

$$\mathbf{r} = \mathbf{r}_B - \mathbf{r}_A = (x_B\mathbf{i} + y_B\mathbf{j} + z_B\mathbf{k}) - (x_A\mathbf{i} + y_A\mathbf{j} + z_A\mathbf{k})$$

- ▶ Or

$$\mathbf{r} = (x_B - x_A)\mathbf{i} + (y_B - y_A)\mathbf{j} + (z_B - z_A)\mathbf{k}$$

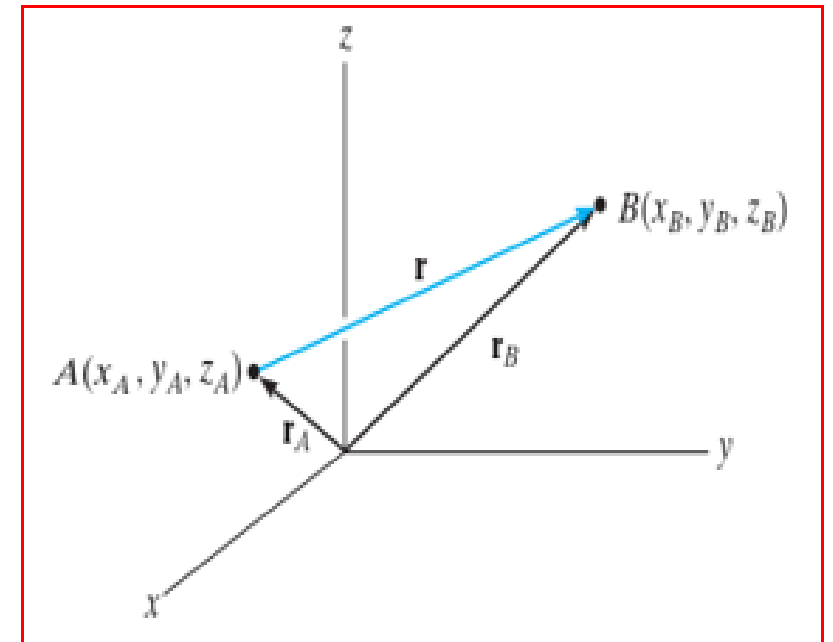

FORCE VECTORS IN SPACE (3D)

POSITION VECTORS

- ▶ We can also form these components directly, by starting at A and moving through a distance of $(x_B - x_A)$ along the positive x axis ($+\mathbf{i}$)
- ▶ then $(y_B - y_A)$ along the positive y axis ($+\mathbf{j}$), and
- ▶ finally $(z_B - z_A)$ along the positive z axis ($+\mathbf{k}$) to get to B .

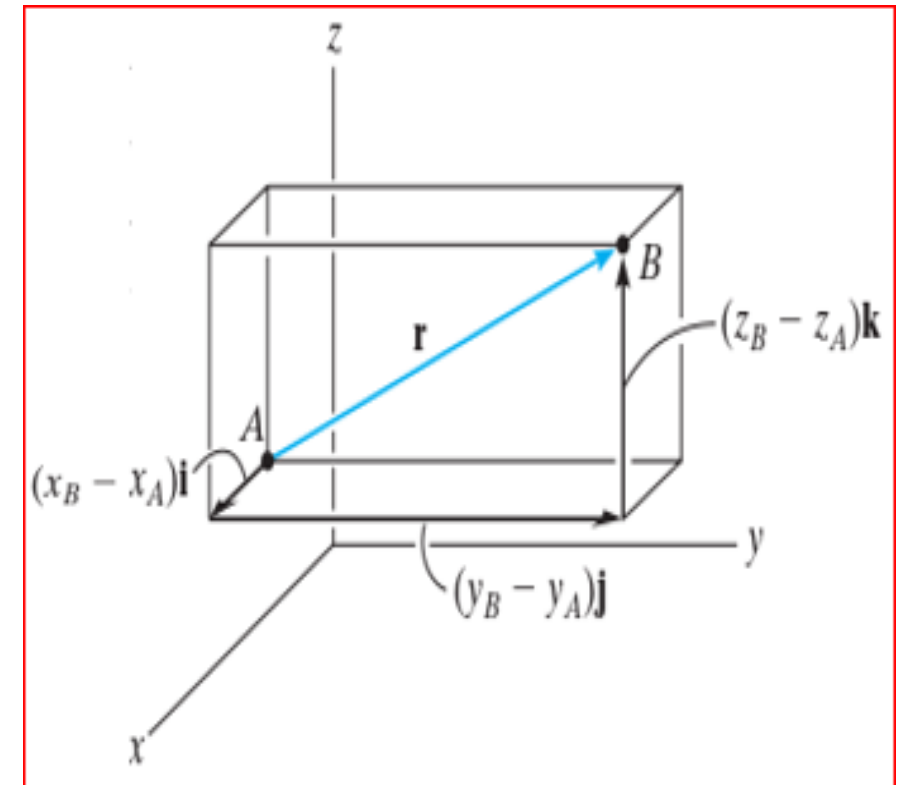

FORCE VECTORS IN SPACE (3D)

POSITION VECTORS – EXAMPLE 2.7

QUESTION

- Determine the lengths of wires AD , BD , and CD . The ring at D is midway between A and B

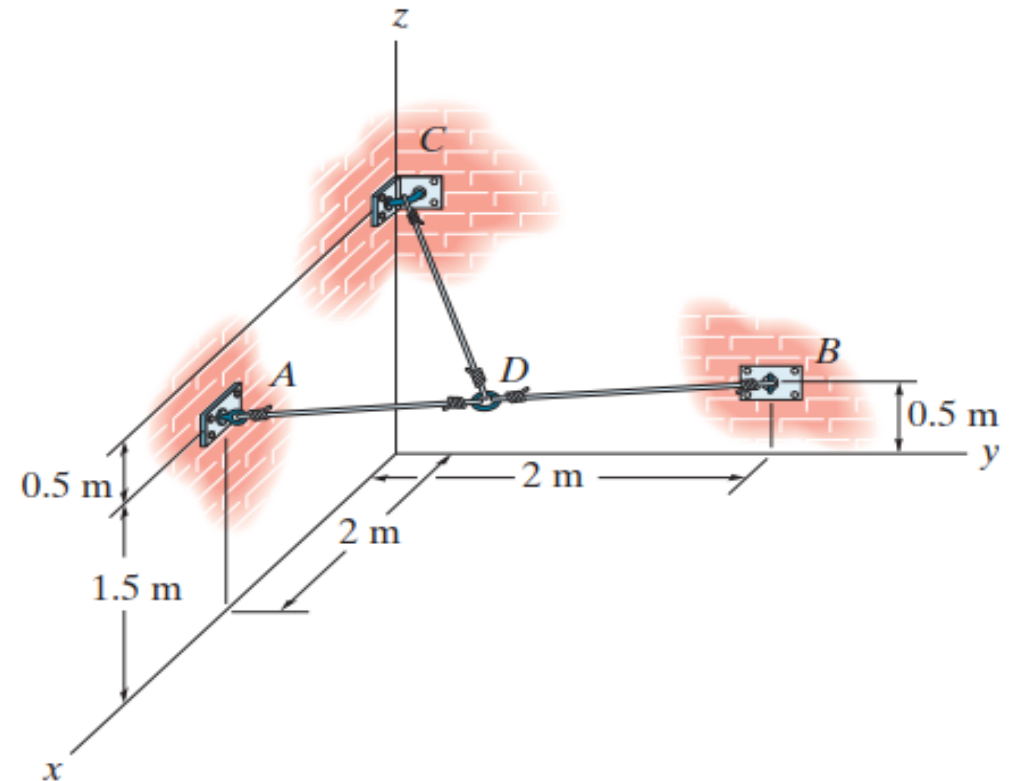

FORCE VECTORS IN SPACE (3D)

POSITION VECTORS – EXAMPLE 2.7

SOLUTION

$$D\left(\frac{2+0}{2}, \frac{0+2}{2}, \frac{1.5+0.5}{2}\right) \text{ m} = D(1, 1, 1) \text{ m}$$

$$\begin{aligned} \mathbf{r}_{AD} &= (1 - 2)\mathbf{i} + (1 - 0)\mathbf{j} + (1 - 1.5)\mathbf{k} \\ &= -1\mathbf{i} + 1\mathbf{j} - 0.5\mathbf{k} \end{aligned}$$

$$\begin{aligned} \mathbf{r}_{BD} &= (1 - 0)\mathbf{i} + (1 - 2)\mathbf{j} + (1 - 0.5)\mathbf{k} \\ &= 1\mathbf{i} - 1\mathbf{j} + 0.5\mathbf{k} \end{aligned}$$

$$\begin{aligned} \mathbf{r}_{CD} &= (1 - 0)\mathbf{i} + (1 - 0)\mathbf{j} + (1 - 2)\mathbf{k} \\ &= 1\mathbf{i} + 1\mathbf{j} - 1\mathbf{k} \end{aligned}$$

$$r_{AD} = \sqrt{(-1)^2 + 1^2 + (-0.5)^2} = 1.50 \text{ m}$$

$$r_{BD} = \sqrt{1^2 + (-1)^2 + 0.5^2} = 1.50 \text{ m}$$

$$r_{CD} = \sqrt{1^2 + 1^2 + (-1)^2} = 1.73 \text{ m}$$

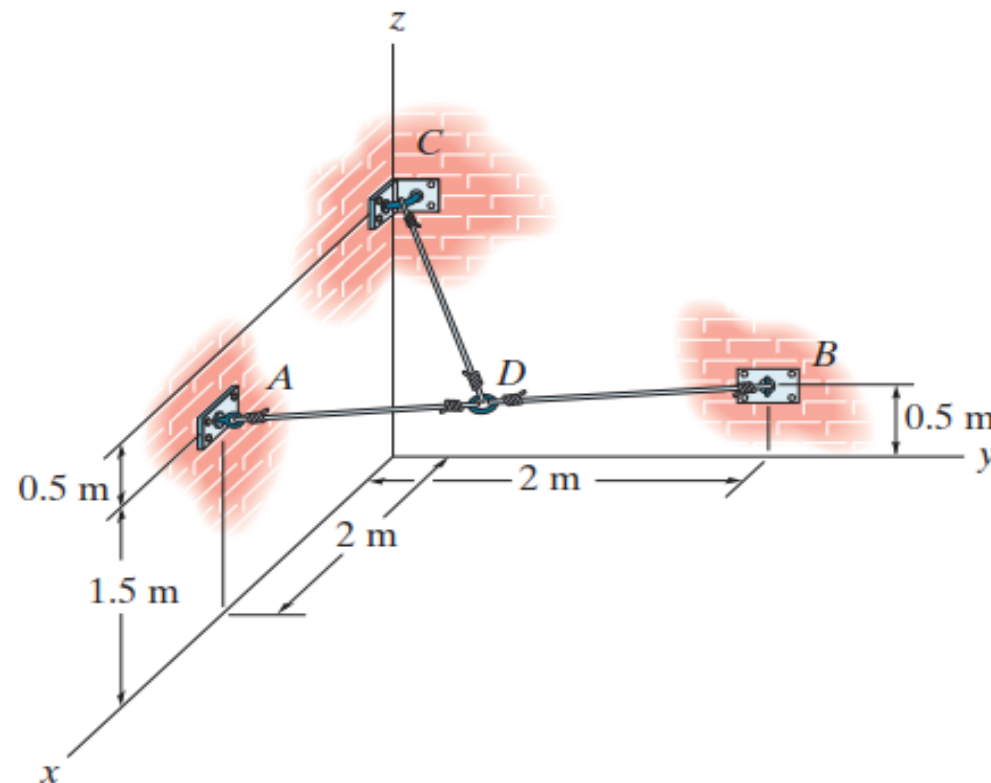

FORCE VECTORS IN SPACE (3D)

POSITION VECTORS – EXAMPLE 2.8

QUESTION

- Express F_B and F_C in Cartesian vector form

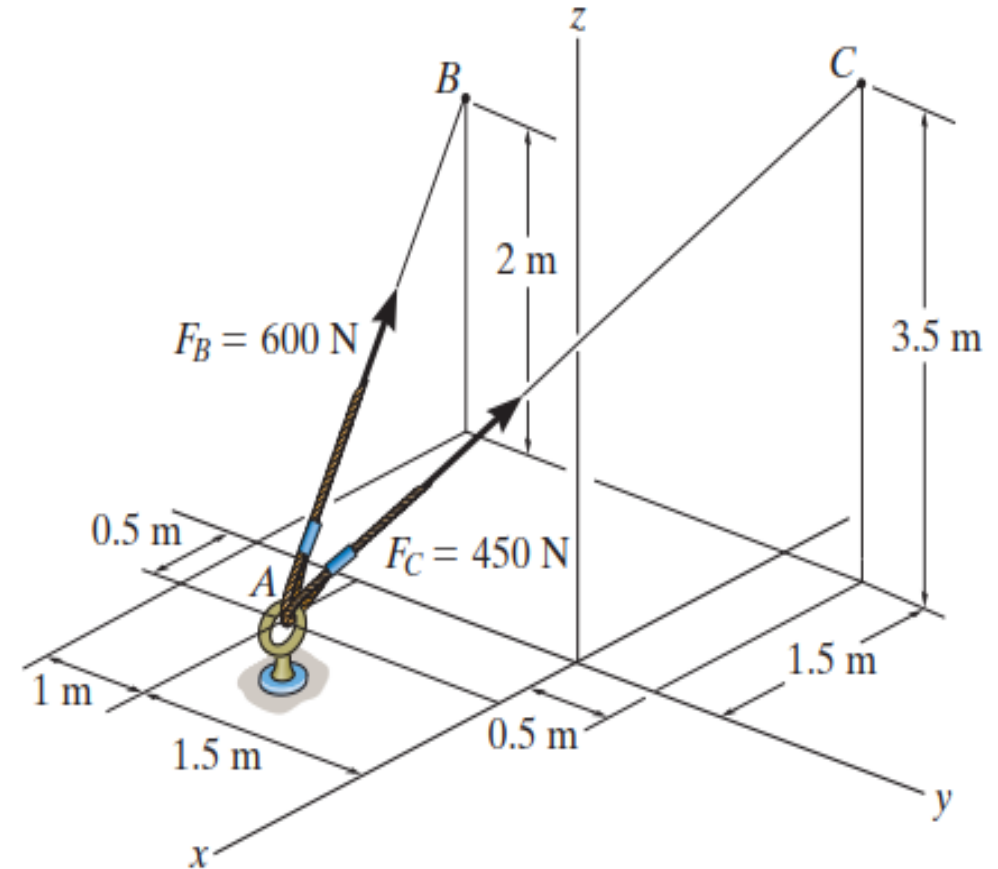

FORCE VECTORS IN SPACE (3D)

POSITION VECTORS – EXAMPLE 2.8

SOLUTION

Force Vectors: The unit vectors \mathbf{u}_B and \mathbf{u}_C of \mathbf{F}_B and \mathbf{F}_C must be determined first. From Fig. *a*

$$\begin{aligned}\mathbf{u}_B &= \frac{\mathbf{r}_B}{r_B} = \frac{(-1.5 - 0.5)\mathbf{i} + [-2.5 - (-1.5)]\mathbf{j} + (2 - 0)\mathbf{k}}{\sqrt{(-1.5 - 0.5)^2 + [-2.5 - (-1.5)]^2 + (2 - 0)^2}} \\ &= -\frac{2}{3}\mathbf{i} - \frac{1}{3}\mathbf{j} + \frac{2}{3}\mathbf{k}\end{aligned}$$

$$\begin{aligned}\mathbf{u}_C &= \frac{\mathbf{r}_C}{r_C} = \frac{(-1.5 - 0.5)\mathbf{i} + [0.5 - (-1.5)]\mathbf{j} + (3.5 - 0)\mathbf{k}}{\sqrt{(-1.5 - 0.5)^2 + [0.5 - (-1.5)]^2 + (3.5 - 0)^2}} \\ &= -\frac{4}{9}\mathbf{i} + \frac{4}{9}\mathbf{j} + \frac{7}{9}\mathbf{k}\end{aligned}$$

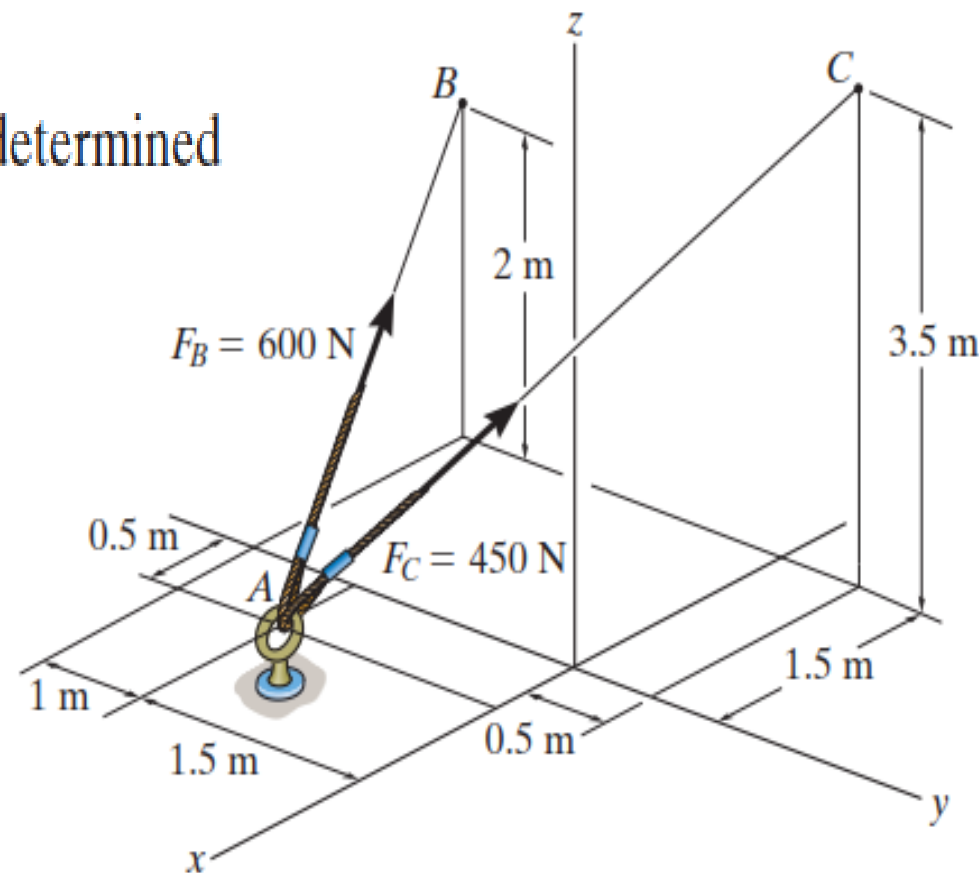

FORCE VECTORS IN SPACE (3D)

POSITION VECTORS – EXAMPLE 2.8

SOLUTION

Thus, the force vectors \mathbf{F}_B and \mathbf{F}_C are given by

$$\mathbf{F}_B = F_B \mathbf{u}_B = 600 \left(-\frac{2}{3} \mathbf{i} - \frac{1}{3} \mathbf{j} + \frac{2}{3} \mathbf{k} \right) = \{-400 \mathbf{i} - 200 \mathbf{j} + 400 \mathbf{k}\} \text{ N}$$

$$\mathbf{F}_C = F_C \mathbf{u}_C = 450 \left(-\frac{4}{9} \mathbf{i} + \frac{4}{9} \mathbf{j} + \frac{7}{9} \mathbf{k} \right) = \{-200 \mathbf{i} + 200 \mathbf{j} + 350 \mathbf{k}\} \text{ N}$$

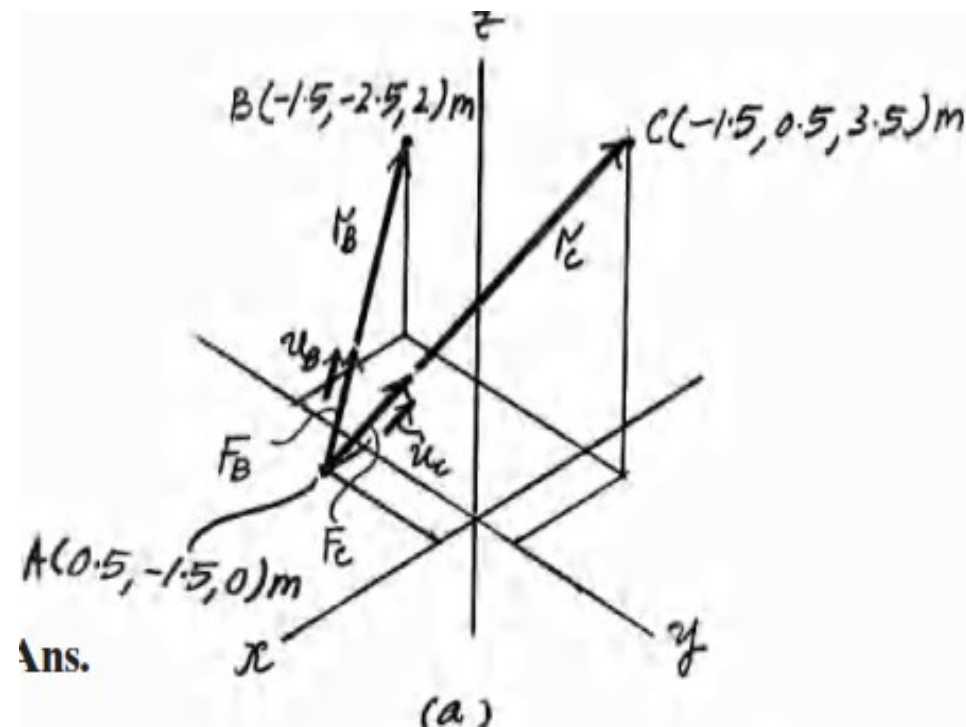
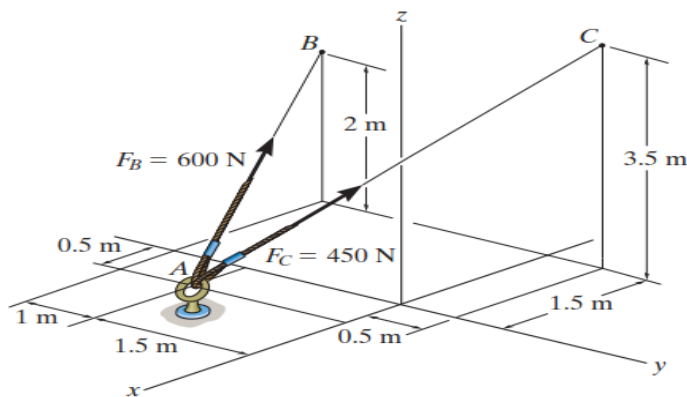

FORCE VECTORS IN SPACE (3D)

Force Vector Directed Along a Line

- ▶ Often in 3D statics problems, the direction of a force is specified by two points through which its line of action passes.
- ▶ Such a situation is shown, where the force F is directed along the cord AB .
- ▶ We can formulate F as a Cartesian vector by realizing that it has the same direction and sense as the position vector \mathbf{r} directed from point A to point B on the cord.

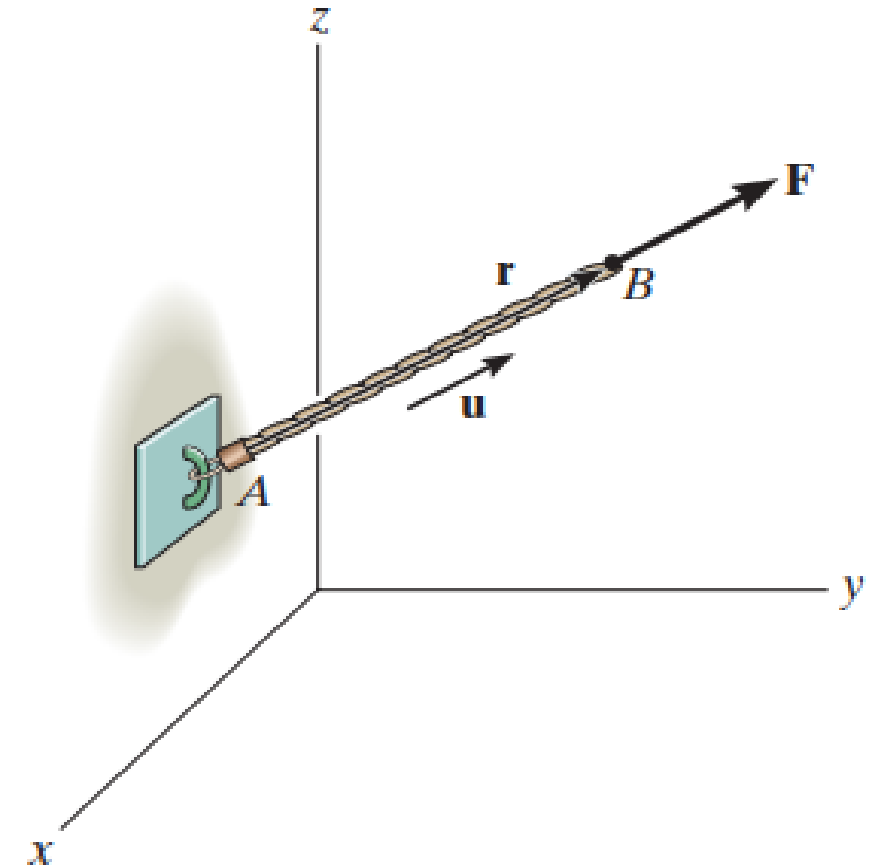

FORCE VECTORS IN SPACE (3D)

Force Vector Directed Along a Line

► This common direction is specified by the unit vector $\mathbf{u} = \mathbf{r}/r$.

► Hence,
$$\mathbf{F} = F\mathbf{u} = F\left(\frac{\mathbf{r}}{r}\right) = F\left(\frac{(x_B - x_A)\mathbf{i} + (y_B - y_A)\mathbf{j} + (z_B - z_A)\mathbf{k}}{\sqrt{(x_B - x_A)^2 + (y_B - y_A)^2 + (z_B - z_A)^2}}\right)$$

► Note that F has units of force and r has units of length.

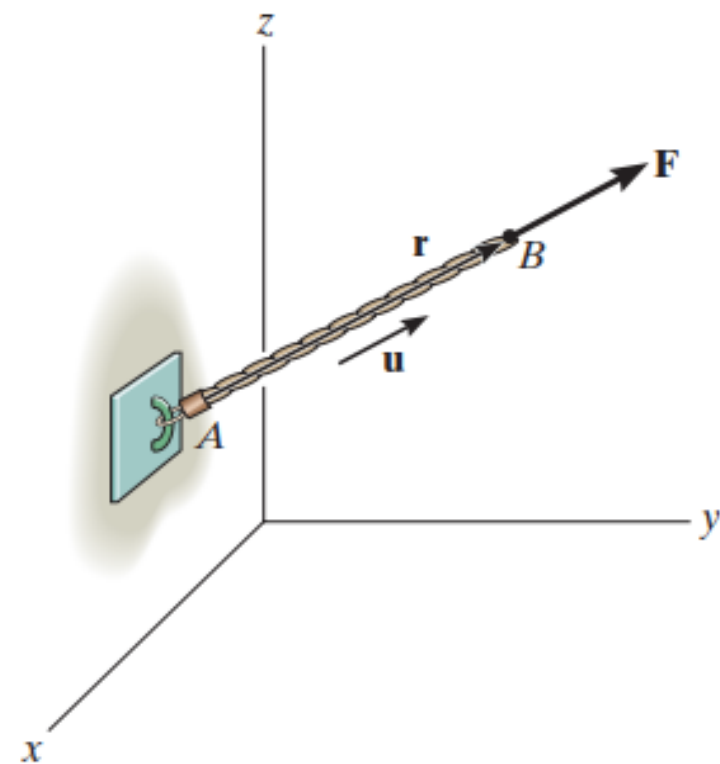

FORCE VECTORS IN SPACE (3D)

Force Vector Directed Along a Line

Important Points

- A position vector locates one point in space relative to another point.
- The easiest way to formulate the components of a position vector is to determine the distance and direction that must be traveled along the x , y , z directions—going from the tail to the head of the vector.
- A force \mathbf{F} acting in the direction of a position vector \mathbf{r} can be represented in Cartesian form if the unit vector \mathbf{u} of the position vector is determined and it is multiplied by the magnitude of the force, i.e., $\mathbf{F} = F\mathbf{u} = F(\mathbf{r}/r)$.

FORCE VECTORS IN SPACE (3D)

FORCE VECTOR DIRECTED ALONG A LINE – EXAMPLE 2.9

QUESTION

- If the force in each cable tied to the bin is 70 lb, determine the magnitude and coordinate direction angles of the resultant force.

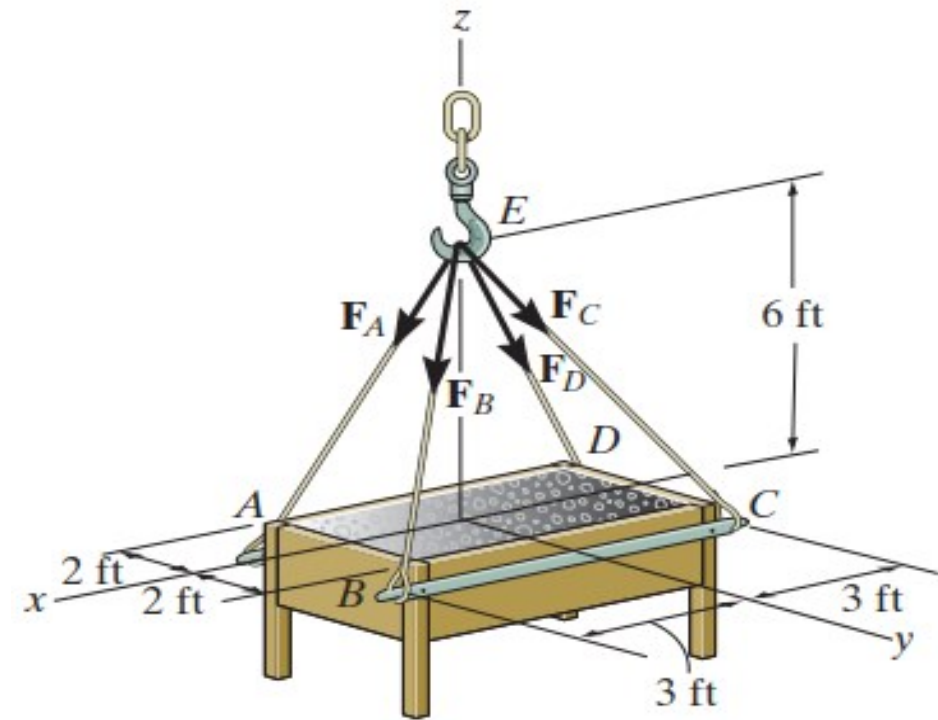

FORCE VECTORS IN SPACE (3D)

FORCE VECTOR DIRECTED ALONG A LINE – EXAMPLE 2.9

$$\mathbf{u}_A = \frac{\mathbf{A}}{A} = \frac{A_x}{A} \mathbf{i} + \frac{A_y}{A} \mathbf{j} + \frac{A_z}{A} \mathbf{k}$$

SOLUTION

Force Vectors: The unit vectors \mathbf{u}_A , \mathbf{u}_B , \mathbf{u}_C and \mathbf{u}_D of \mathbf{F}_A , \mathbf{F}_B , \mathbf{F}_C and \mathbf{F}_D must be determined

$$\mathbf{u}_A = \frac{\mathbf{r}_A}{r_A} = \frac{(3-0)\mathbf{i} + (-2-0)\mathbf{j} + (0-6)\mathbf{k}}{\sqrt{(3-0)^2 + (-2-0)^2 + (0-6)^2}} = \frac{3}{7}\mathbf{i} - \frac{2}{7}\mathbf{j} - \frac{6}{7}\mathbf{k}$$

$$\mathbf{u}_B = \frac{\mathbf{r}_B}{r_B} = \frac{(3-0)\mathbf{i} + (2-0)\mathbf{j} + (0-6)\mathbf{k}}{\sqrt{(3-0)^2 + (2-0)^2 + (0-6)^2}} = \frac{3}{7}\mathbf{i} + \frac{2}{7}\mathbf{j} - \frac{6}{7}\mathbf{k}$$

$$\mathbf{u}_C = \frac{\mathbf{r}_C}{r_C} = \frac{(-3-0)\mathbf{i} + (2-0)\mathbf{j} + (0-6)\mathbf{k}}{\sqrt{(-3-0)^2 + (2-0)^2 + (0-6)^2}} = -\frac{3}{7}\mathbf{i} + \frac{2}{7}\mathbf{j} - \frac{6}{7}\mathbf{k}$$

$$\mathbf{u}_D = \frac{\mathbf{r}_D}{r_D} = \frac{(-3-0)\mathbf{i} + (-2-0)\mathbf{j} + (0-6)\mathbf{k}}{\sqrt{(-3-0)^2 + (-2-0)^2 + (0-6)^2}} = -\frac{3}{7}\mathbf{i} - \frac{2}{7}\mathbf{j} - \frac{6}{7}\mathbf{k}$$

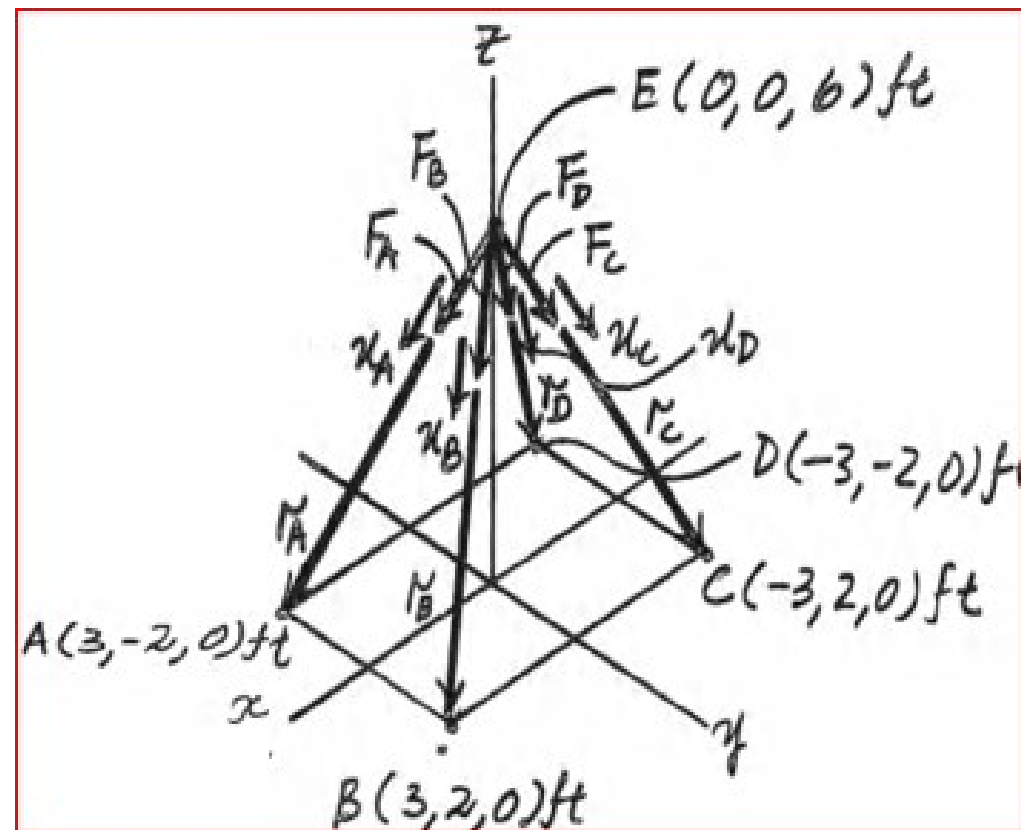

FORCE VECTORS IN SPACE (3D)

FORCE VECTOR DIRECTED ALONG A LINE – EXAMPLE 2.9

$$\mathbf{u}_A = \frac{\mathbf{A}}{A} = \frac{A_x}{A} \mathbf{i} + \frac{A_y}{A} \mathbf{j} + \frac{A_z}{A} \mathbf{k}$$

SOLUTION

Thus, the force vectors \mathbf{F}_A , \mathbf{F}_B , \mathbf{F}_C and \mathbf{F}_D are given by

$$\mathbf{F}_A = F_A \mathbf{u}_A = 70 \left(\frac{3}{7} \mathbf{i} - \frac{2}{7} \mathbf{j} - \frac{6}{7} \mathbf{k} \right) = [30\mathbf{i} - 20\mathbf{j} - 60\mathbf{k}] \text{ lb}$$

$$\mathbf{F}_B = F_B \mathbf{u}_B = 70 \left(\frac{3}{7} \mathbf{i} + \frac{2}{7} \mathbf{j} - \frac{6}{7} \mathbf{k} \right) = [30\mathbf{i} + 20\mathbf{j} - 60\mathbf{k}] \text{ lb}$$

$$\mathbf{F}_C = F_C \mathbf{u}_C = 70 \left(-\frac{3}{7} \mathbf{i} + \frac{2}{7} \mathbf{j} - \frac{6}{7} \mathbf{k} \right) = [-30\mathbf{i} + 20\mathbf{j} - 60\mathbf{k}] \text{ lb}$$

$$\mathbf{F}_D = F_D \mathbf{u}_D = 70 \left(-\frac{3}{7} \mathbf{i} - \frac{2}{7} \mathbf{j} - \frac{6}{7} \mathbf{k} \right) = [-30\mathbf{i} - 20\mathbf{j} - 60\mathbf{k}] \text{ lb}$$

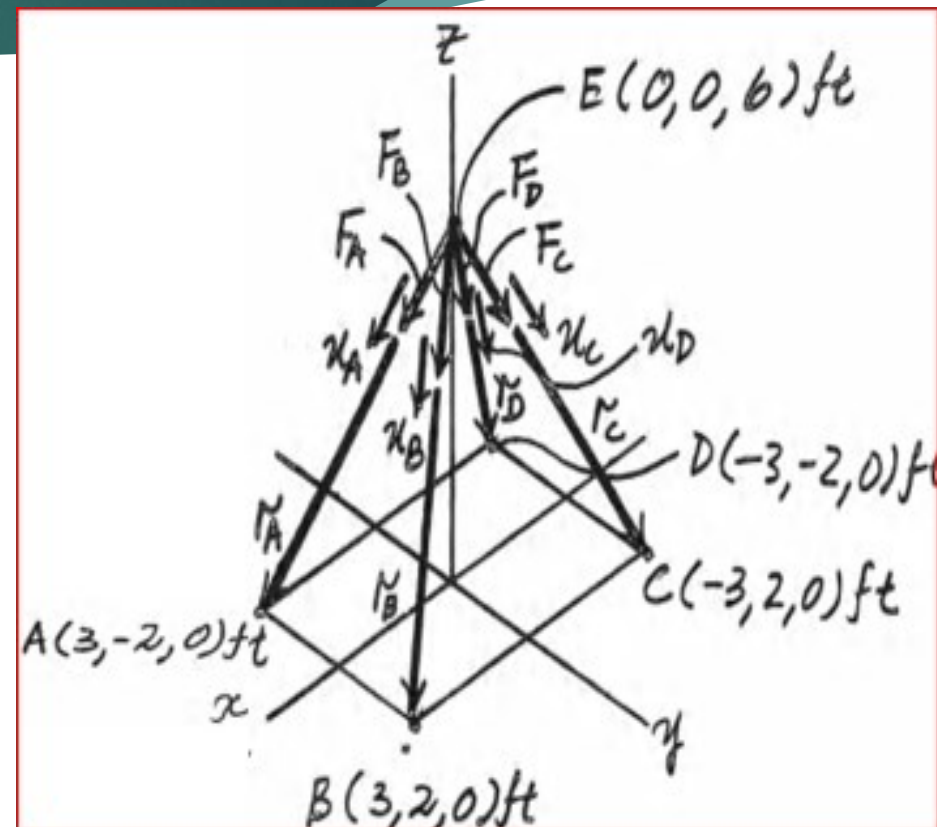

FORCE VECTORS IN SPACE (3D)

FORCE VECTOR DIRECTED ALONG A LINE – EXAMPLE 2.9

SOLUTION

Resultant force \mathbf{F}_R is calculated as shown

$$\begin{aligned}\mathbf{F}_R &= \mathbf{F}_A + \mathbf{F}_B + \mathbf{F}_C + \mathbf{F}_D = (30\mathbf{i} - 20\mathbf{j} - 60\mathbf{k}) \\ &+ (30\mathbf{i} + 20\mathbf{j} - 60\mathbf{k}) + (-30\mathbf{i} + 20\mathbf{j} - 60\mathbf{k}) \\ &+ (-30\mathbf{i} - 20\mathbf{j} - 60\mathbf{k}) = \{-240\mathbf{k}\} \text{ N}\end{aligned}$$

The magnitude of F_R is $F_R = \sqrt{(F_R)_x^2 + (F_R)_y^2 + (F_R)_z^2}$
 $= \sqrt{0 + 0 + (-240)^2} = 240 \text{ lb}$

& the coordinate direction angles of F_R are

$$\cos \alpha = \frac{A_x}{A} \quad \cos \beta = \frac{A_y}{A} \quad \cos \gamma = \frac{A_z}{A}$$

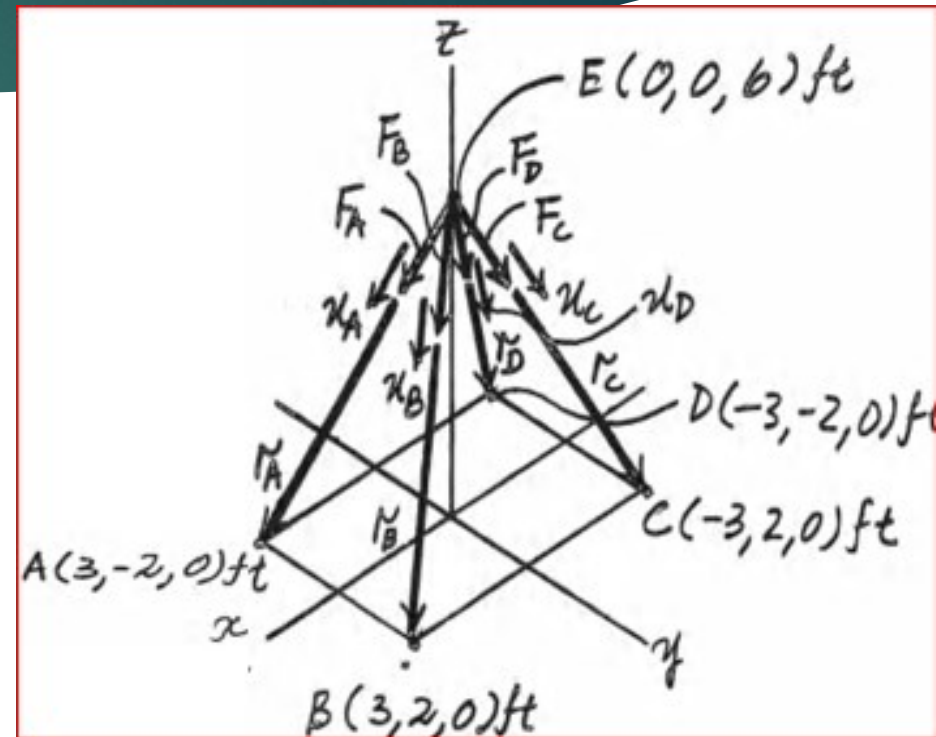

$$\alpha = \cos^{-1} \left[\frac{(F_R)_x}{F_R} \right] = \cos^{-1} \left(\frac{0}{240} \right) = 90^\circ \quad \beta = \cos^{-1} \left[\frac{(F_R)_y}{F_R} \right] = \cos^{-1} \left(\frac{0}{240} \right) = 90^\circ \quad \gamma = \cos^{-1} \left[\frac{(F_R)_z}{F_R} \right] = \cos^{-1} \left(\frac{-240}{240} \right) = 180^\circ$$

FORCE VECTORS IN SPACE (3D)

81

FORCE VECTOR DIRECTED ALONG A LINE – EXAMPLE 2.10

QUESTION

- ▶ Each of the four forces acting at E has a magnitude of 28 kN. Express each force as a Cartesian vector and determine the resultant force.

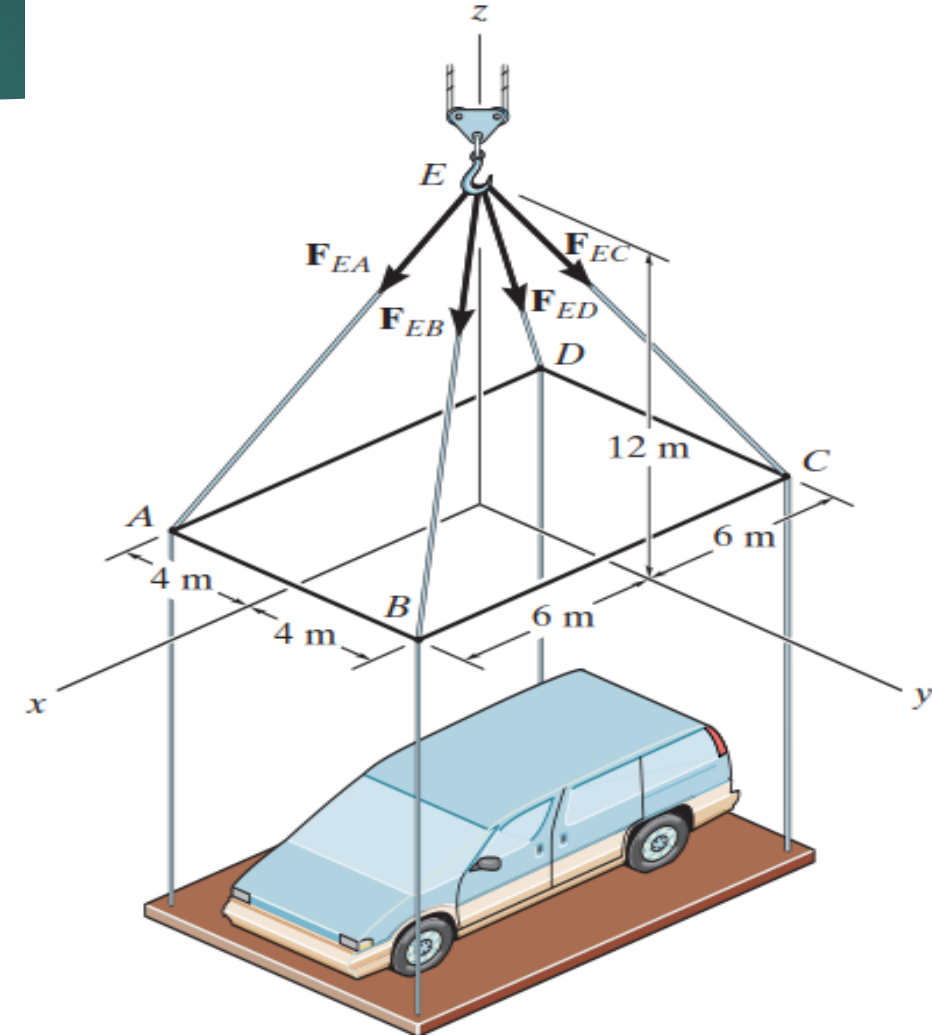

FORCE VECTORS IN SPACE (3D)

FORCE VECTOR DIRECTED ALONG A LINE – EXAMPLE 2.10

SOLUTION

$$\mathbf{F}_{EA} = 28 \left(\frac{6}{14} \mathbf{i} - \frac{4}{14} \mathbf{j} - \frac{12}{14} \mathbf{k} \right) \quad \mathbf{F}_{EC} = \{-12\mathbf{i} + 8\mathbf{j} - 24\mathbf{k}\} \text{ kN}$$

$$\mathbf{F}_{EA} = \{12\mathbf{i} - 8\mathbf{j} - 24\mathbf{k}\} \text{ kN}$$

$$\mathbf{F}_{ED} = 28 \left(\frac{-6}{14} \mathbf{i} - \frac{4}{14} \mathbf{j} - \frac{12}{14} \mathbf{k} \right)$$

$$\mathbf{F}_{EB} = 28 \left(\frac{6}{14} \mathbf{i} + \frac{4}{14} \mathbf{j} - \frac{12}{14} \mathbf{k} \right)$$

$$\mathbf{F}_{ED} = \{-12\mathbf{i} - 8\mathbf{j} - 24\mathbf{k}\} \text{ kN}$$

$$\mathbf{F}_{EB} = \{12\mathbf{i} + 8\mathbf{j} - 24\mathbf{k}\} \text{ kN}$$

$$\mathbf{F}_R = \mathbf{F}_{EA} + \mathbf{F}_{EB} + \mathbf{F}_{EC} + \mathbf{F}_{ED}$$

$$\mathbf{F}_{EC} = 28 \left(\frac{-6}{14} \mathbf{i} + \frac{4}{14} \mathbf{j} - \frac{12}{14} \mathbf{k} \right)$$

$$= \{-96\mathbf{k}\} \text{ kN}$$

