

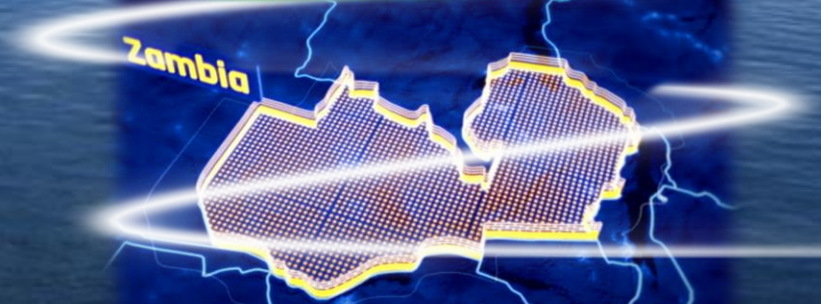

Lecture A5

CEE 2219: STATICS AND INTRODUCTION TO MECHANICS OF MATERIALS

EQUILIBRIUM OF A RIGID BODY





CEE 2219 – STATICS & INTRODUCTION TO MECHANICS OF MATERIALS

Lecture A5

- ✓ FREE-BODY DIAGRAM
- ✓ REACTIONS AT SUPPORTS AND CONNECTIONS FOR 2D & 3D
- ✓ EQUILIBRIUM OF A RIGID BODY IN 2D & 3D
- ✓ STATICALLY INDETERMINATE REACTIONS



LECTURE OBJECTIVES



- ❖ To develop the equations of equilibrium for a rigid body.
- ❖ To introduce the concept of the free-body diagram for a rigid body.
- ❖ To show how to solve rigid-body equilibrium problems using the equations of equilibrium.





CHAPTER INTRODUCTION

- Statics deals primarily with the description of the force conditions necessary and sufficient to maintain the equilibrium of engineering structures.

- This lecture on equilibrium, therefore, constitutes the most important part of statics, and the procedures developed here form the basis for solving problems in both statics and dynamics.

$$\sum \vec{F} = 0 \quad \sum \vec{M}_o = \sum (\vec{r} \times \vec{F}) = 0$$

- We will make continual use of the concepts developed in previous lecture notes involving forces, moments, couples, and resultants as we apply the principles of equilibrium.

$$\sum F_x = 0 \quad \sum F_y = 0 \quad \sum F_z = 0$$

$$\sum M_x = 0 \quad \sum M_y = 0 \quad \sum M_z = 0$$

- When a body is in equilibrium, the resultant of all forces acting on it is zero.



CHAPTER INTRODUCTION

- Thus, the resultant force R and the resultant couple M are both zero, and we have the equilibrium equations $\longrightarrow R = \sum \vec{F} = 0 \quad M = \sum \vec{M}_O = \sum (\vec{r} \times \vec{F}) = 0$
- Therefore for a rigid body in static equilibrium, the external forces and moments are balanced and will impart no translational or rotational motion to the body.

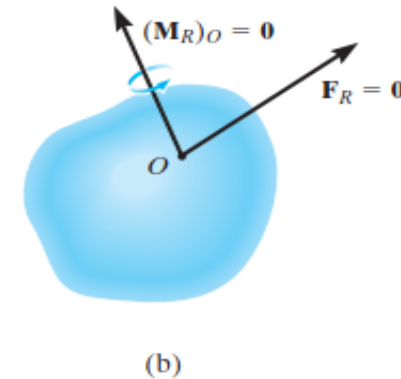
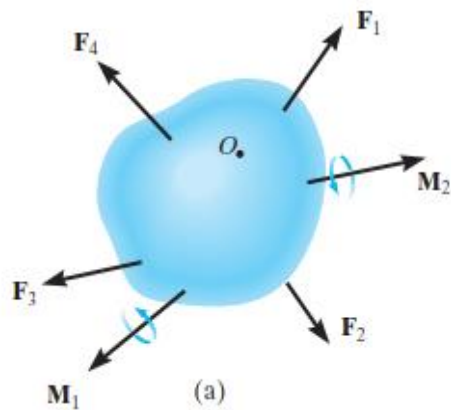

CHAPTER INTRODUCTION

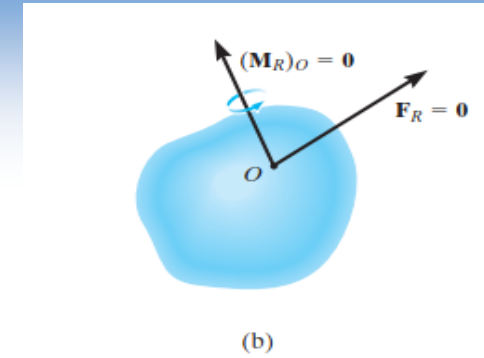
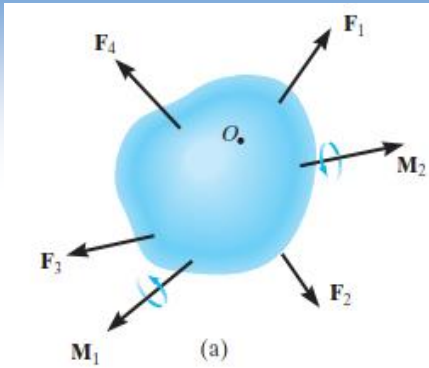

- The necessary and sufficient condition for the static equilibrium of a body are that the resultant force and couple from all external forces form a system equivalent to zero

$$\sum \vec{F} = 0 \quad \sum \vec{M}_O = \sum (\vec{r} \times \vec{F}) = 0$$

- Resolving each force and moment into its rectangular components leads to 6 scalar equations which also express the conditions for static equilibrium

$$\begin{aligned} \sum F_x = 0 & \quad \sum F_y = 0 & \quad \sum F_z = 0 \\ \sum M_x = 0 & \quad \sum M_y = 0 & \quad \sum M_z = 0 \end{aligned}$$

- We can also consider summing moments about some other point, such as point A we require

$$\sum \mathbf{M}_A = \mathbf{r} \times \mathbf{F}_R + (\mathbf{M}_R)_O = \mathbf{0}$$

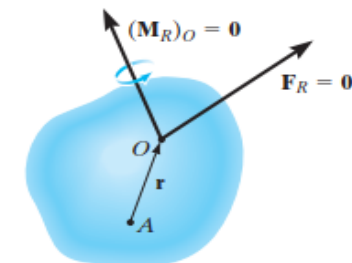

CHAPTER INTRODUCTION



- When applying the equations of equilibrium, we will assume that the body remains rigid. In reality, however, all bodies deform when subjected to loads.
- Although this is the case, most engineering materials such as steel and concrete are very rigid and so their deformation is usually very small.
- Therefore, when applying the equations of equilibrium, we can generally assume that the body will remain rigid and not deform under the applied load without introducing any significant error.





CHAPTER INTRODUCTION

- And note that all physical bodies are three-dimensional, but we can treat many of them as two-dimensional when the forces to which they are subjected act in a single plane or can be projected onto a single plane.
- When this simplification is not possible, the problem must be treated as three-dimensional.
- Therefore in this lecture we will first discuss the equilibrium of bodies subjected to 2D and in the second part the equilibrium of bodies subjected to 3D will be presented.





EQUILIBRIUM IN TWO DIMENSIONS (2D)

- Two-dimensional or coplanar force systems are where a force acting on a rigid body lies in or is projected onto a single plane and, any couple moments acting on the body are directed perpendicular to this plane.
- For example, the airplane shown, has a plane of symmetry through its centre axis, and so the loads acting on the airplane are symmetrical with respect to this plane.
- Thus, each of the two wing tires will support the same load T , which is represented on the side (two-dimensional) view of the plane as $2T$.

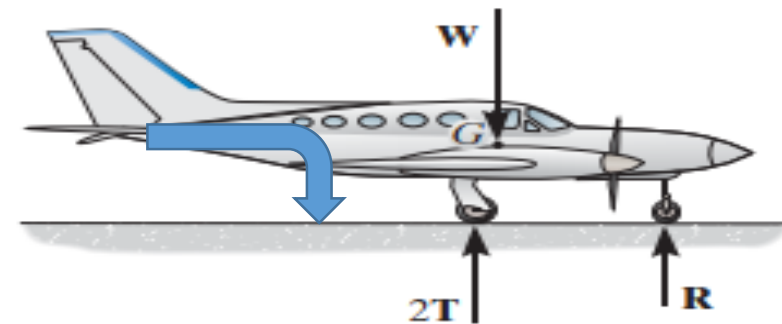

FREE BODY DIAGRAM (2D)



- Successful application of the equations of equilibrium requires a complete specification of all the known and unknown external forces that act on the body.
- The best way to account for these forces is to draw a free-body diagram (FBD).
- The FBD is a sketch of the outlined shape of the body, which represents it as being isolated or “free” from its surroundings, i.e., a “free body.” On this sketch it is necessary to show all the forces and couple moments that the surroundings exert on the body so that these effects can be accounted for when the equations of equilibrium are applied.
- A thorough understanding of how to draw a free-body diagram is of primary importance for solving problems in mechanics.





FREE BODY DIAGRAM (2D)

Modeling the Action of Forces (Support Reactions)

- Before discussing how to draw a FBD, we will first consider the various types of reactions that occur at supports and points of contact between bodies subjected to coplanar force systems.
- As a general rule,
- A support prevents the translation of a body in a given direction by exerting a force on the body in the opposite direction.
- A support prevents the rotation of a body in a given direction by exerting a couple moment on the body in the opposite direction.



FREE BODY DIAGRAM (2D)

Modeling the Action of Forces (Support Reactions)

- For example, consider three ways in which a horizontal member, i.e a beam supported at its end.
- One method consists of a roller or cylinder. This support **only prevents** the beam from **translating** in the **vertical direction**, the roller will only exert a force on the beam in this direction

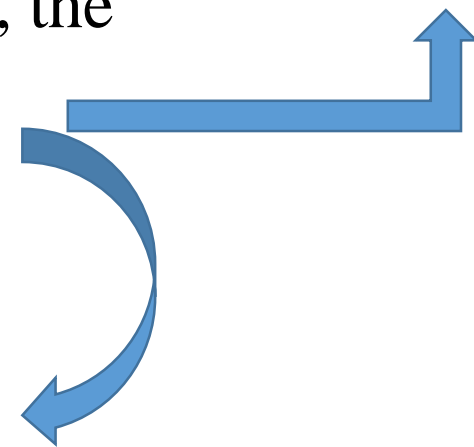
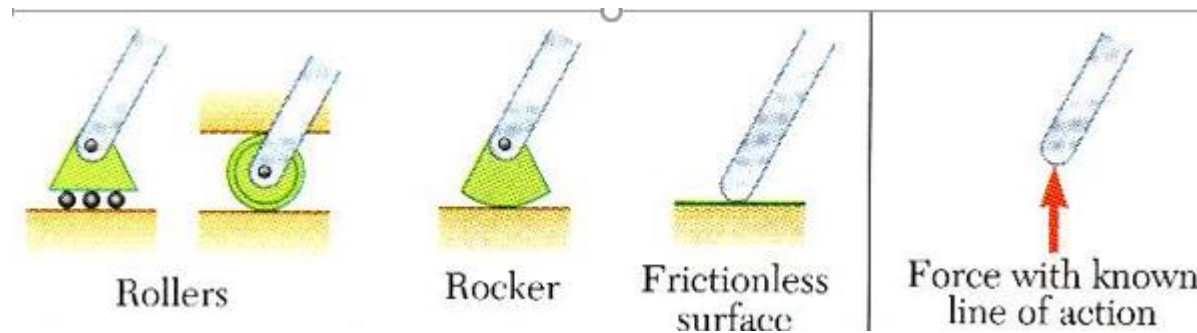
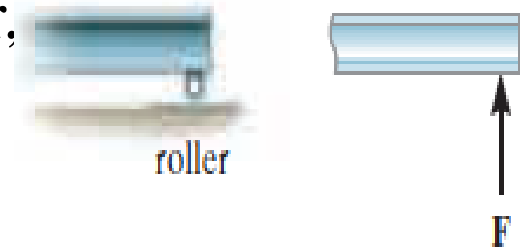

FREE BODY DIAGRAM (2D)

Modeling the Action of Forces (Support Reactions)

- The beam can be supported in a more restrictive manner by using a pin
- The pin passes through a hole in the beam and two leaves which are fixed to the ground.
- The pin **prevents translation** of the beam in **any direction** and so the pin must exert a force F on the beam in the **opposite direction** (Newton's third law)
- For purposes of analysis, it is generally easier to represent this resultant force F by its two rectangular components F_x and F_y

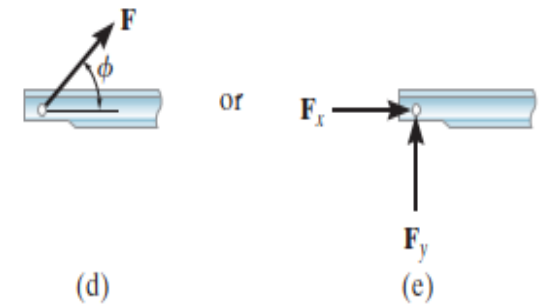
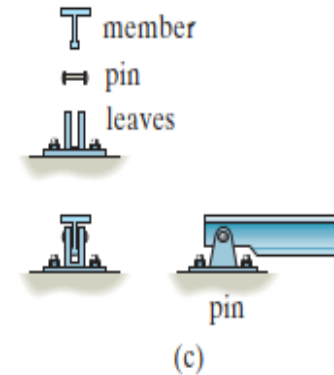

FREE BODY DIAGRAM (2D)



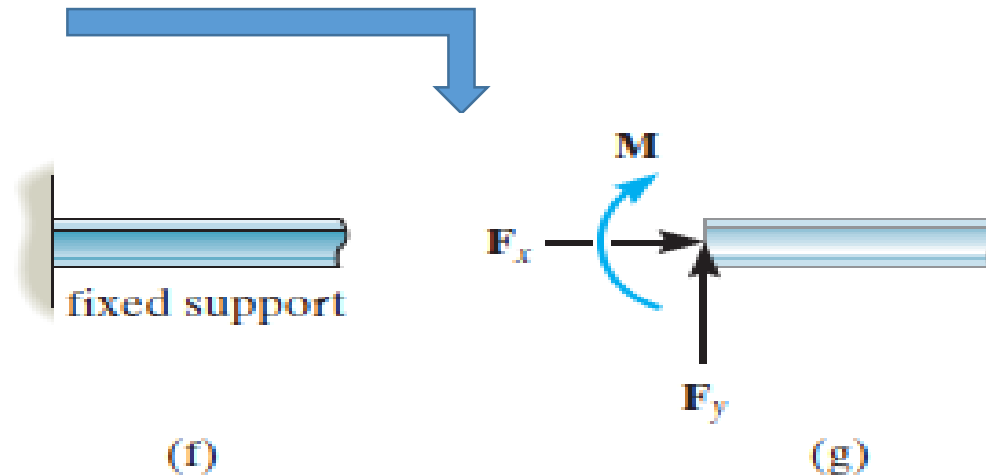

Modeling the Action of Forces (Support Reactions)



- The most restrictive way to support the beam would be to use a fixed support as shown.
- This support will prevent both translation and rotation of the beam.
- To do this a force and couple moment must be developed on the beam at its point of connection

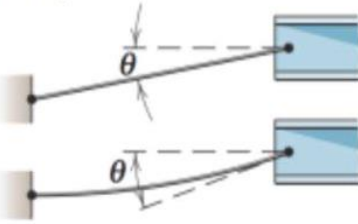
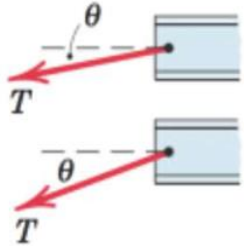

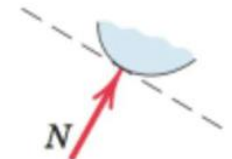
FREE BODY DIAGRAM (2D)

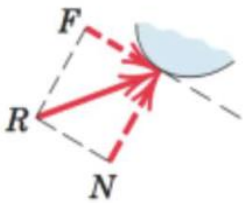
Modeling the Action of Forces (Support Reactions)

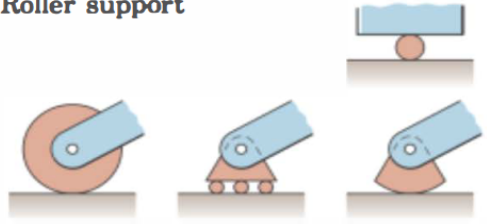
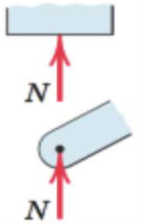
MODELING THE ACTION OF FORCES IN TWO-DIMENSIONAL ANALYSIS	
Type of Contact and Force Origin	Action on Body to Be Isolated
<p>1. Flexible cable, belt, chain, or rope</p> <p>Weight of cable negligible</p> <p>Weight of cable not negligible</p> 	 <p>Force exerted by a flexible cable is always a tension away from the body in the direction of the cable.</p>
<p>2. Smooth surfaces</p> 	 <p>Contact force is compressive and is normal to the surface.</p>
<p>3. Rough surfaces</p> 	 <p>Rough surfaces are capable of supporting a tangential component F (frictional force) as well as a normal component N of the resultant contact force R.</p>

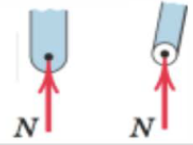
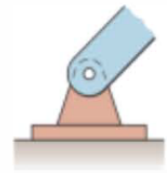
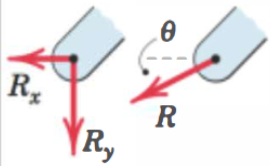
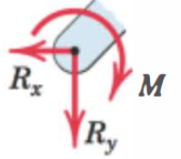
MODELING THE ACTION OF FORCES IN TWO-DIMENSIONAL ANALYSIS (cont.)	
Type of Contact and Force Origin	Action on Body to Be Isolated
<p>4. Roller support</p> 	 <p>Roller, rocker, or ball support transmits a compressive force normal to the supporting surface.</p>
<p>5. Freely sliding guide</p> 	 <p>Collar or slider free to move along smooth guides; can support force normal to guide only.</p>
<p>6. Pin connection</p> 	<p>Pin free to turn</p>  <p>Pin not free to turn</p>  <p>A freely hinged pin connection is capable of supporting a force in any direction in the plane normal to the pin axis. We may either show two components R_x and R_y, or a magnitude R and direction θ. A pin not free to turn also supports a couple M.</p>

FREE BODY DIAGRAM (2D)

Modeling the Action of Forces (Support Reactions)



MODELING THE ACTION OF FORCES IN TWO-DIMENSIONAL ANALYSIS (cont.)	
Type of Contact and Force Origin	Action on Body to Be Isolated
<p>7. Built-in or fixed support</p>	<p>A built-in or fixed support is capable of supporting an axial force F, a transverse force V (shear force), and a couple M (bending moment) to prevent rotation.</p>
<p>8. Gravitational attraction</p>	<p>The resultant of gravitational attraction on all elements of a body of mass m is the weight $W = mg$ and acts toward the center of the earth through the center of gravity G.</p>

MODELING THE ACTION OF FORCES IN TWO-DIMENSIONAL ANALYSIS (cont.)	
Type of Contact and Force Origin	Action on Body to Be Isolated
<p>9. Spring action</p>	<p>Spring force is tensile if the spring is stretched and compressive if compressed. For a linearly elastic spring the stiffness k is the force required to deform the spring a unit distance.</p>
<p>10. Torsional spring action</p>	<p>For a linear torsional spring, the applied moment M is proportional to the angular deflection θ from the neutral position. The stiffness k_T is the moment required to deform the spring one radian.</p>

FREE BODY DIAGRAM (2D)

Modeling the Action of Forces (Support Reactions)

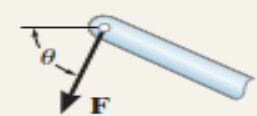
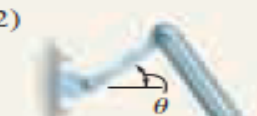
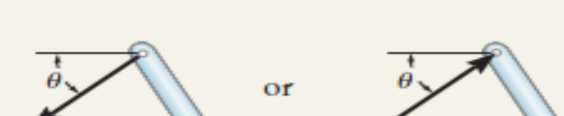
- Lists of common types of supports for bodies subjected to coplanar force systems showing the types of reactions they exert on their contacting members. (In all cases the angle is assumed to be known.)
- The List also shows the number of unknown reaction

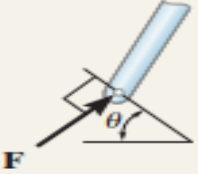

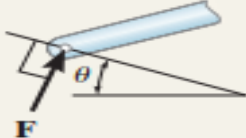

TABLE 5-1 Supports for Rigid Bodies Subjected to Two-Dimensional Force Systems		
Types of Connection	Reaction	Number of Unknowns
(1)  cable		One unknown. The reaction is a tension force which acts away from the member in the direction of the cable.
(2)  weightless link		One unknown. The reaction is a force which acts along the axis of the link.
(3)  roller		One unknown. The reaction is a force which acts perpendicular to the surface at the point of contact.



FREE BODY DIAGRAM (2D)

Modeling the Action of Forces (Support Reactions)

TABLE 5-1 Supports for Rigid Bodies Subjected to Two-Dimensional Force Systems

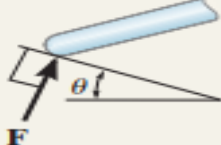
Types of Connection	Reaction	Number of Unknowns
<p>(3)</p>  <p>roller</p>		<p>One unknown. The reaction is a force which acts perpendicular to the surface at the point of contact.</p>
<p>(4)</p>  <p>rocker</p>		<p>One unknown. The reaction is a force which acts perpendicular to the surface at the point of contact.</p>
<p>(5)</p>  <p>smooth contacting surface</p>		<p>One unknown. The reaction is a force which acts perpendicular to the surface at the point of contact.</p>

FREE BODY DIAGRAM (2D)



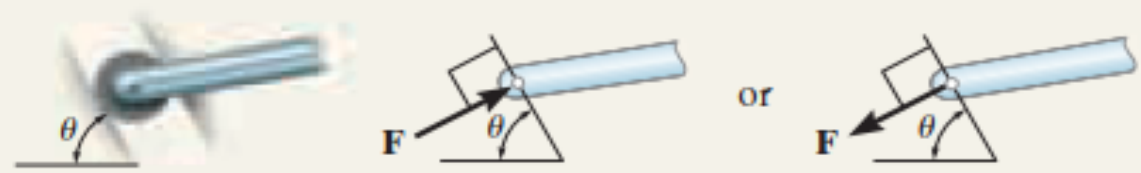
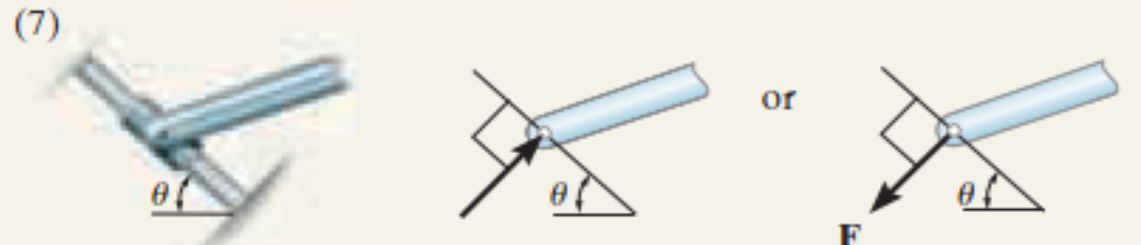

Modeling the Action of Forces (Support Reactions)

TABLE 5-1 Supports for Rigid Bodies Subjected to Two-Dimensional Force Systems

Types of Connection	Reaction	Number of Unknowns
<p>(6)</p>  <p>roller or pin in confined smooth slot</p>	<p>One unknown. The reaction is a force which acts perpendicular to the slot.</p>	<p>One unknown. The reaction is a force which acts perpendicular to the slot.</p>
<p>(7)</p>  <p>member pin connected to collar on smooth rod</p>	<p>One unknown. The reaction is a force which acts perpendicular to the rod.</p>	<p>One unknown. The reaction is a force which acts perpendicular to the rod.</p>

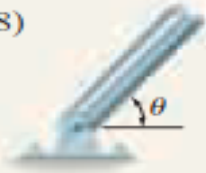
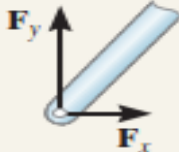
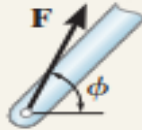
FREE BODY DIAGRAM (2D)

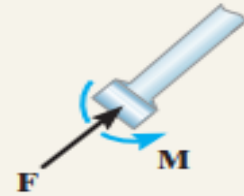
Modeling the Action of Forces (Support Reactions)

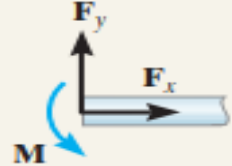
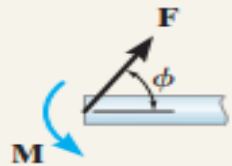
TABLE 5-1 Continued		
Types of Connection	Reaction	Number of Unknowns
(8)  smooth pin or hinge	 or 	Two unknowns. The reactions are two components of force, or the magnitude and direction ϕ of the resultant force. Note that ϕ and θ are not necessarily equal [usually not, unless the rod shown is a link as in (2)].
(9)  member fixed connected to collar on smooth rod		Two unknowns. The reactions are the couple moment and the force which acts perpendicular to the rod.
(10)  fixed support	 or 	Three unknowns. The reactions are the couple moment and the two force components, or the couple moment and the magnitude and direction ϕ of the resultant force.



FREE BODY DIAGRAM (2D)

Modeling the Action of Forces (Support Reactions)

- Typical examples of connections and reactions



(© Russell C. Hibbeler)

The cable exerts a force on the bracket in the direction of the cable. (1)

This concrete girder rests on the ledge that is assumed to act as a smooth contacting surface. (5) (© Russell C. Hibbeler)



The rocker support for this bridge girder allows horizontal movement so the bridge is free to expand and contract due to a change in temperature. (4) (© Russell C. Hibbeler)

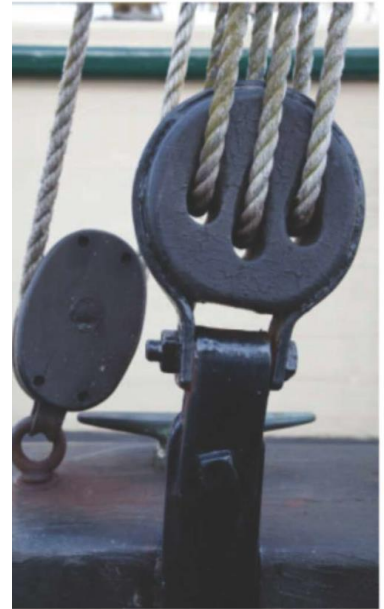

Purestock/Imagine.com



The rocker support for this bridge girder allows horizontal movement so the bridge is free to expand and contract due to a change in temperature. (4) (© Russell C. Hibbeler)

The floor beams of this building are welded together and thus form fixed connections. (10) (© Russell C. Hibbeler)



(a)

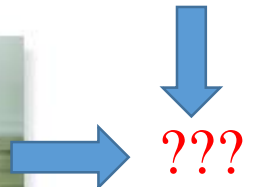



CONSTRUCTION OF FREE BODY DIAGRAMS (2D)

- *Note that a free-body diagram is the most important single step in the solution of problems in mechanics.* The full procedure for drawing a free-body diagram which isolates a body or system consists of the following steps.
- **Step 1**: Decide which system to isolate. The system chosen should usually involve one or more of the desired unknown quantities.
- **Step 2**: Next isolate the chosen system by drawing a diagram which represents its complete external boundary. This boundary defines the isolation of the system from all other attracting or contacting bodies, which are considered removed. **This step is often the most crucial of all. Make certain that you have completely isolated the system before proceeding with the next step.**





CONSTRUCTION OF FREE BODY DIAGRAMS (2D)

- **Step 3:** Identify all forces which act on the isolated system as applied by the removed contacting and attracting bodies, and represent them in their proper positions on the diagram of the isolated system.
- Make a systematic traverse of the entire boundary to identify all contact forces. Include body forces such as weights, where appreciable.
- Represent all known/unknown forces by vector arrows, each with its proper magnitude/unknown magnitude, direction, and sense indicated.
- If the sense of the vector is also unknown, you must arbitrarily assign a sense. It is necessary to be **consistent** with the assigned characteristics of unknown forces throughout all of the calculations. If you are consistent, the solution of the equilibrium equations will reveal the correct senses.





CONSTRUCTION OF FREE BODY DIAGRAMS (2D)

- **Step 4**: Show the choice of coordinate axes directly on the diagram.
- Pertinent dimensions may also be represented for convenience.
- Note, however, that the free-body diagram serves the purpose of focusing attention on the action of the external forces, and therefore the diagram should not be cluttered with excessive irrelevant information.
- Clearly distinguish force arrows from arrows representing quantities other than forces.
- For this purpose a colored pencil may be used.



CONSTRUCTION OF FREE BODY DIAGRAMS (2D)

Sample FBDs

SAMPLE FREE-BODY DIAGRAMS

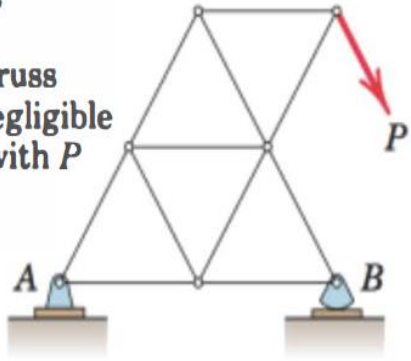
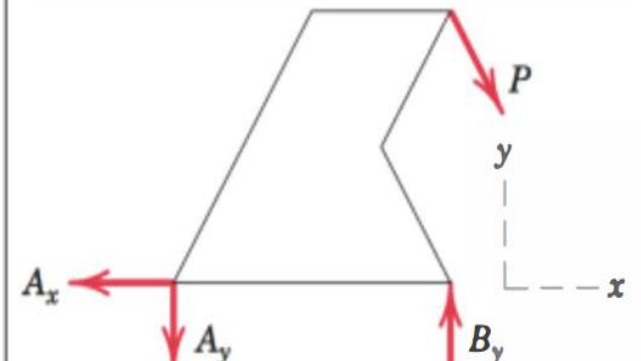
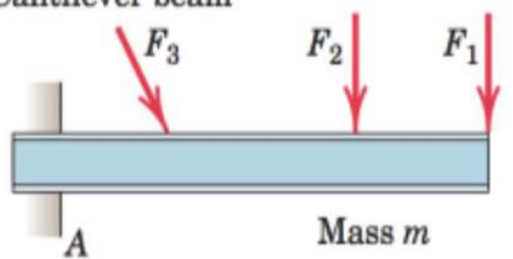
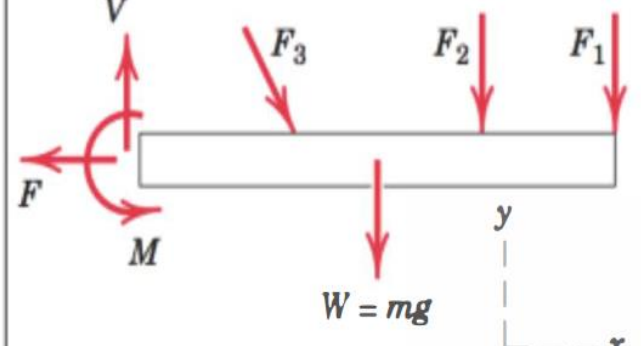
Mechanical System	Free-Body Diagram of Isolated Body
<p>1. Plane truss</p> <p>Weight of truss assumed negligible compared with P</p> 	
<p>2. Cantilever beam</p> 	

3. Beam

Smooth surface contact at A.
Mass m

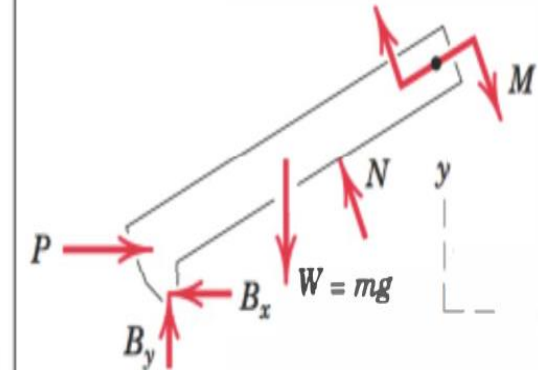
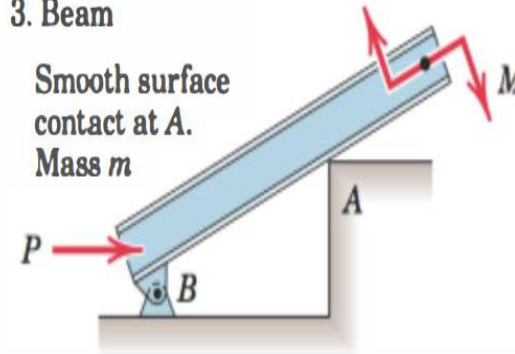

4. Rigid system of interconnected bodies analyzed a single unit

Weight of mechanism neglected

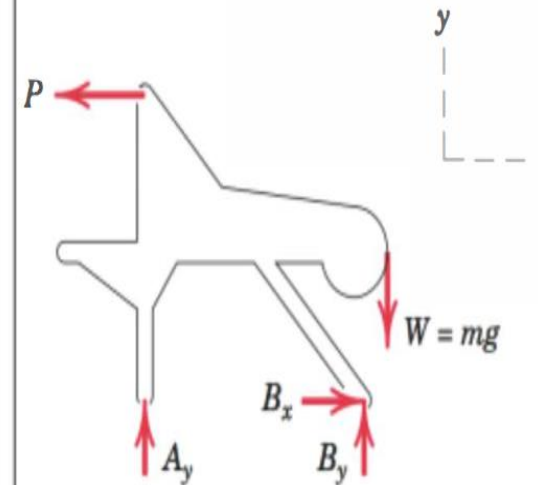
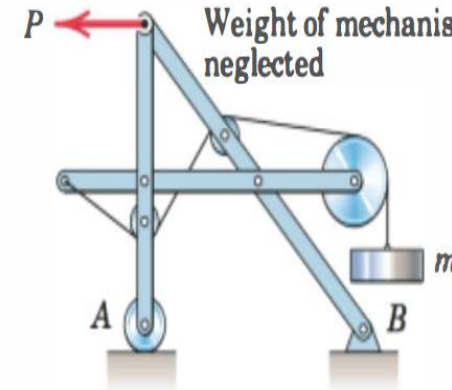

CONSTRUCTION OF FREE BODY DIAGRAM (2D)

Example 5-1

- First step in the static equilibrium analysis of a rigid body is identification of all forces acting on the body with a *free-body* diagram.
- Select the extent of the free-body and detach it from the ground and all other bodies.
- Indicate point of application, magnitude, and direction of external forces, including the rigid body weight.

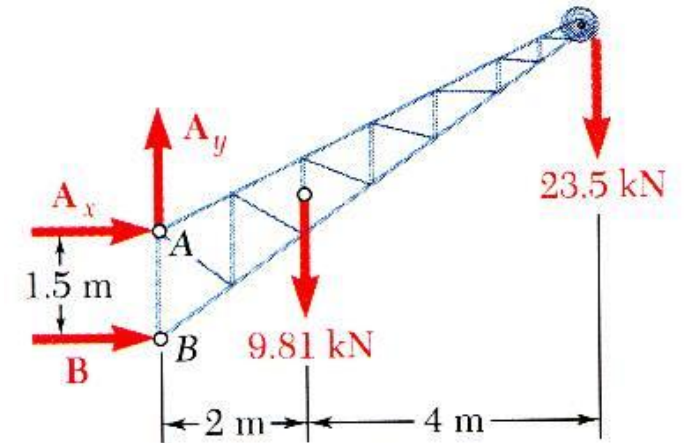
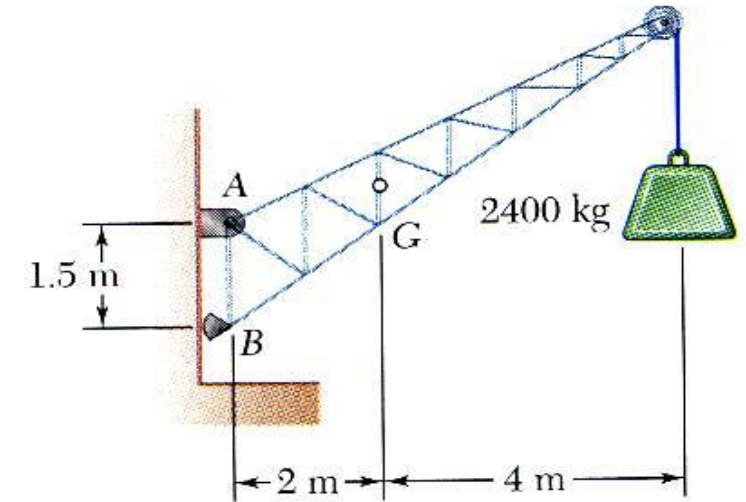

CONSTRUCTION OF FREE BODY DIAGRAM (2D)

Example 5-1

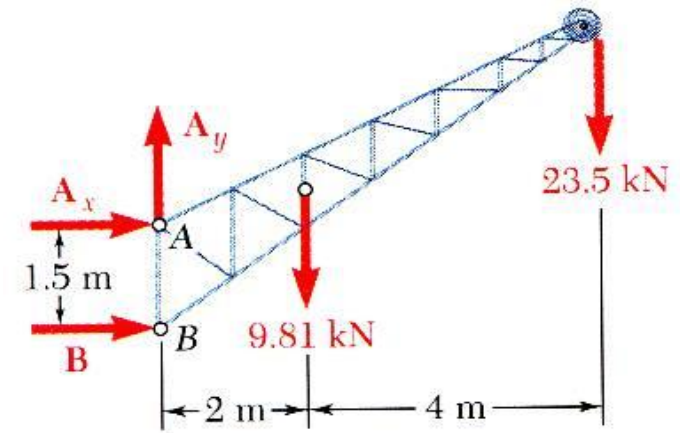
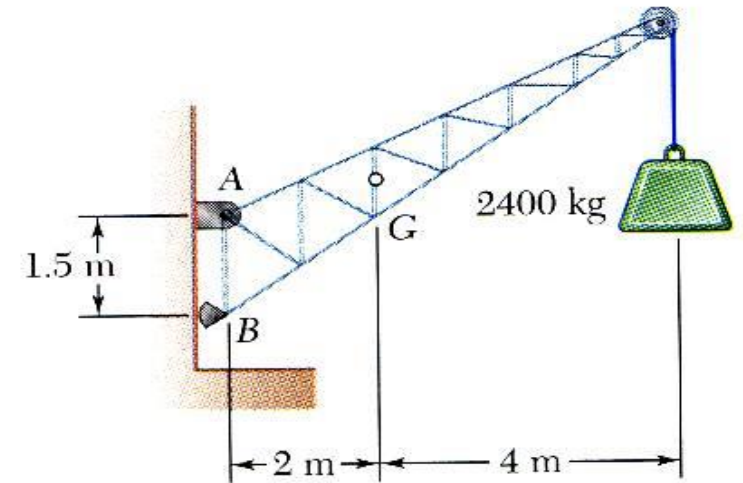

- Indicate point of application and assumed direction of unknown applied forces.
- These usually consist of reactions through which the ground and other bodies oppose the possible motion of the rigid body.
- Include the dimensions necessary to compute the moments of the forces.



CONSTRUCTION OF FREE BODY DIAGRAMS (2D)

FBDs Exercises

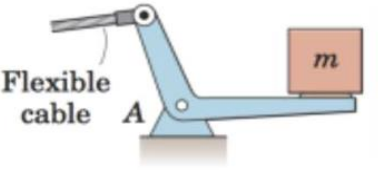
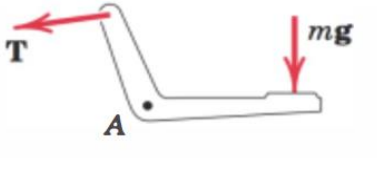
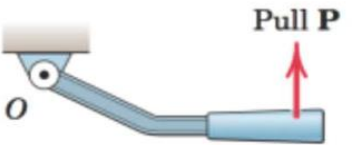
• Complete the FBD Shown below

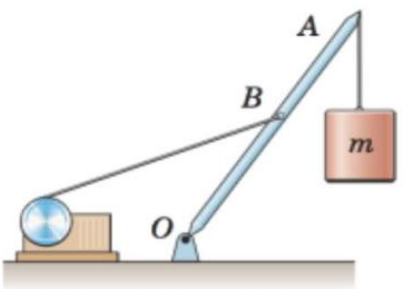
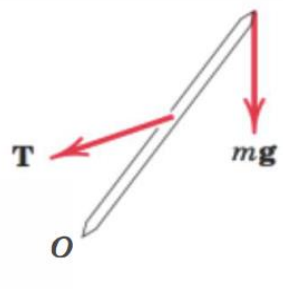
	Body	Incomplete FBD
1. Bell crank supporting mass m with pin support at A .		
2. Control lever applying torque to shaft at O .		
3. Boom OA , of negligible mass compared with mass m . Boom hinged at O and supported by hoisting cable at B .		

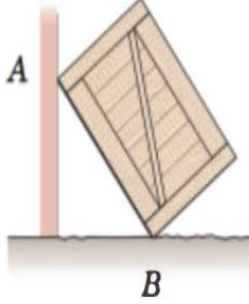
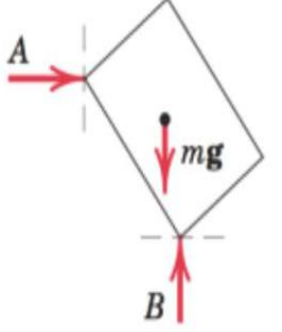
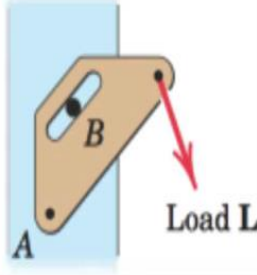
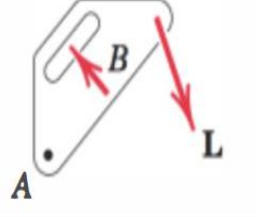
4. Uniform crate of mass 8 leaning against smooth vertical wall and supported on a rough horizontal surface.		
5. Loaded bracket supported by pin connection at A and fixed pin in smooth slot at B .		



CONSTRUCTION OF FREE BODY DIAGRAMS (2D)

FBDs Exercises

- Complete the FBD Shown below if Necessary

	Body	Wrong or Incomplete FBD
1. Lawn roller of mass m being pushed up incline θ .		
2. Prybar lifting body A having smooth horizontal surface. Bar rests on horizontal rough surface.		
3. Uniform pole of mass m being hoisted into position by winch. Horizontal supporting surface notched to prevent slipping of pole.		

4. Supporting angle bracket for frame; pin joints.		
5. Bent rod welded to support at A and subjected to two forces and couple.		

FREE BODY DIAGRAM (2D)

Example 5.2

Question

- Draw the free-body diagram of the foot lever shown below. The operator applies a vertical force to the pedal so that the spring is stretched 1.5 in. and the force on the link at B is 20 lb.

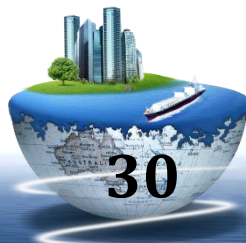
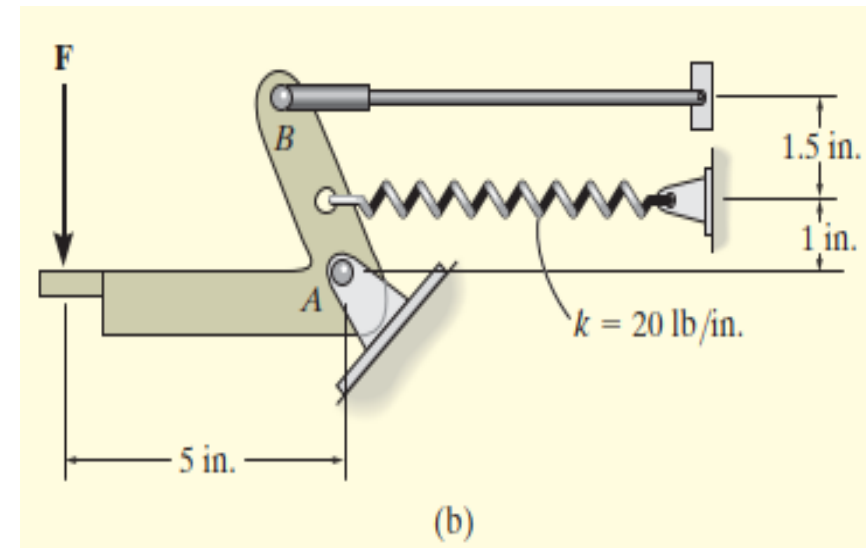

FREE BODY DIAGRAM (2D)

Example 5.2

Solution

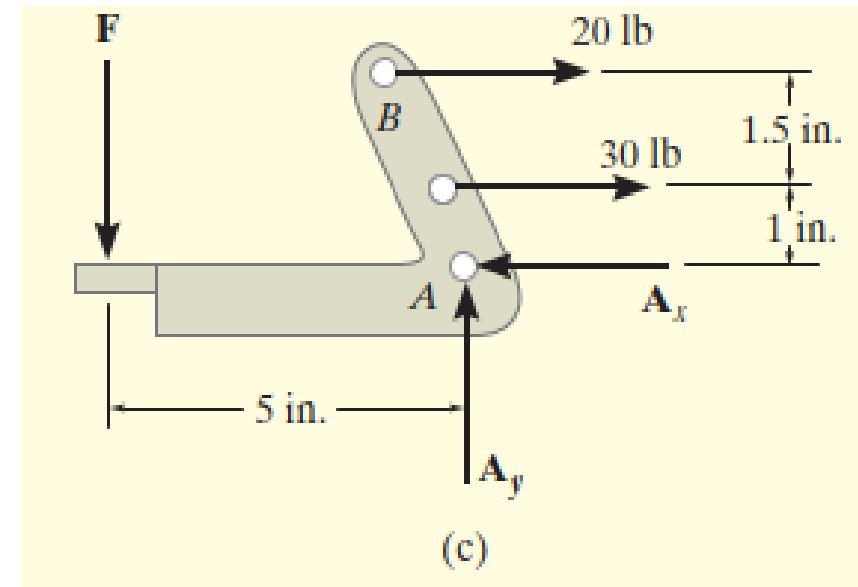
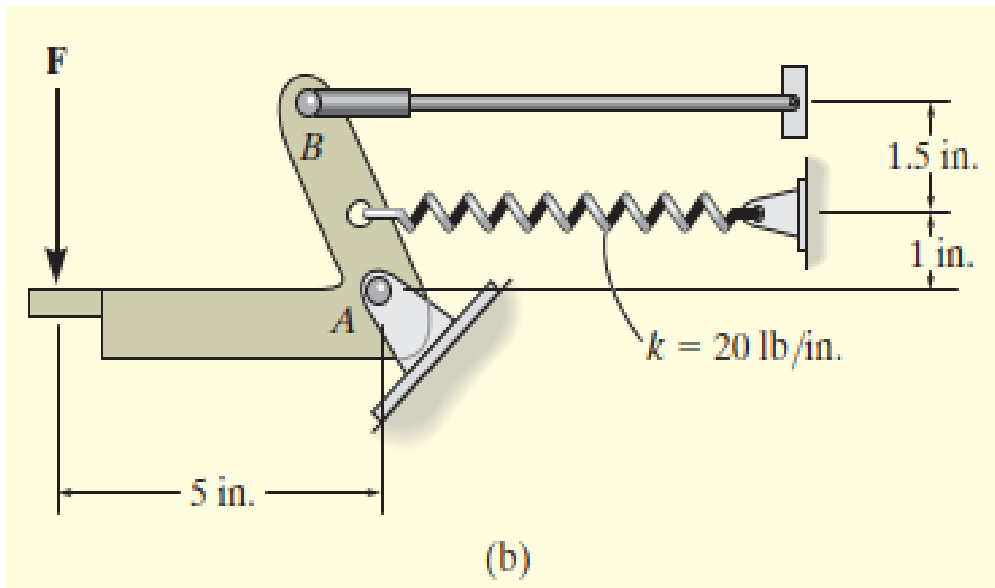

The Idealized Model

The FBD



FREE BODY DIAGRAM (2D)

Example 5.3

Questio

- Two smooth pipes, each having a mass of 300 kg, are supported by the forked tines of the tractor in shown. Draw the free-body diagrams for each pipe and both pipes together.



FREE BODY DIAGRAM (2D)

Example 5.3

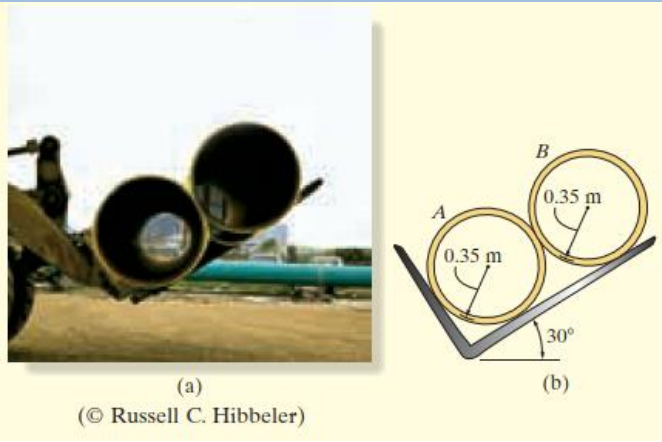

Solutions

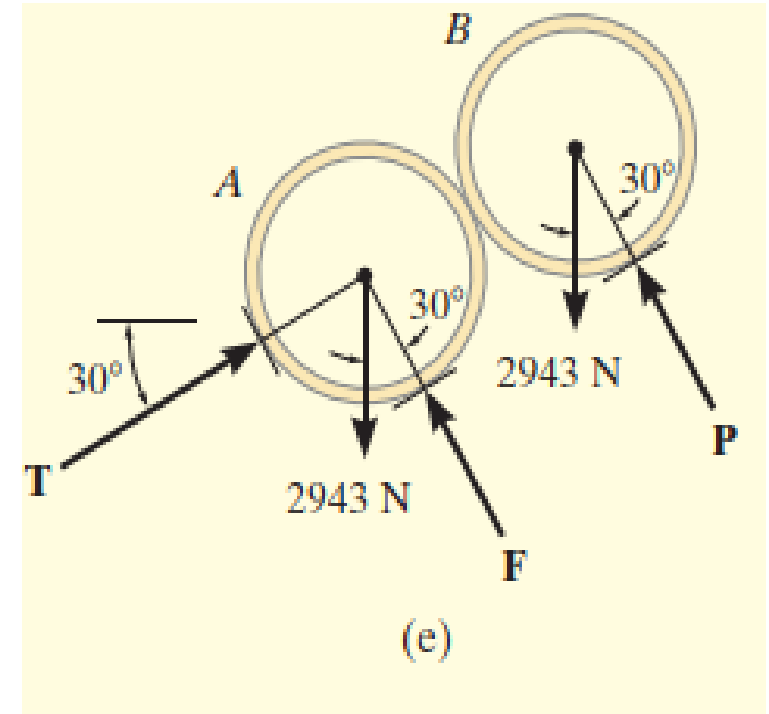
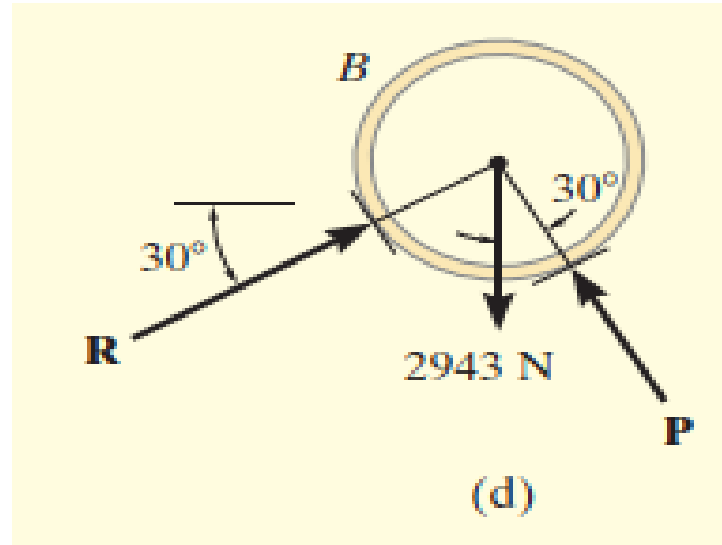
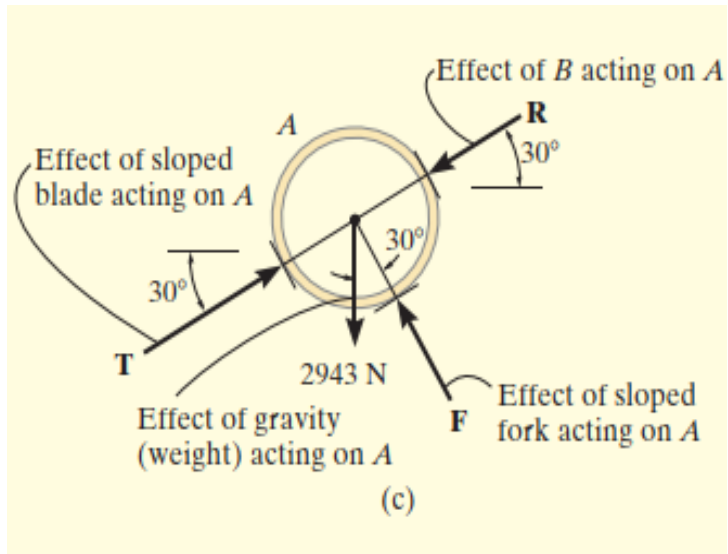

FREE BODY DIAGRAM (2D)

Example 5.4

Question

a) Draw a FBD of the crane boom, which is supported by a pin at A and cable BC. The load of 1250 lb is suspended at B and the boom weighs 650 lb.

b) Draw a FBD of member ABC, which is supported by a smooth collar at A, roller at B & link CD

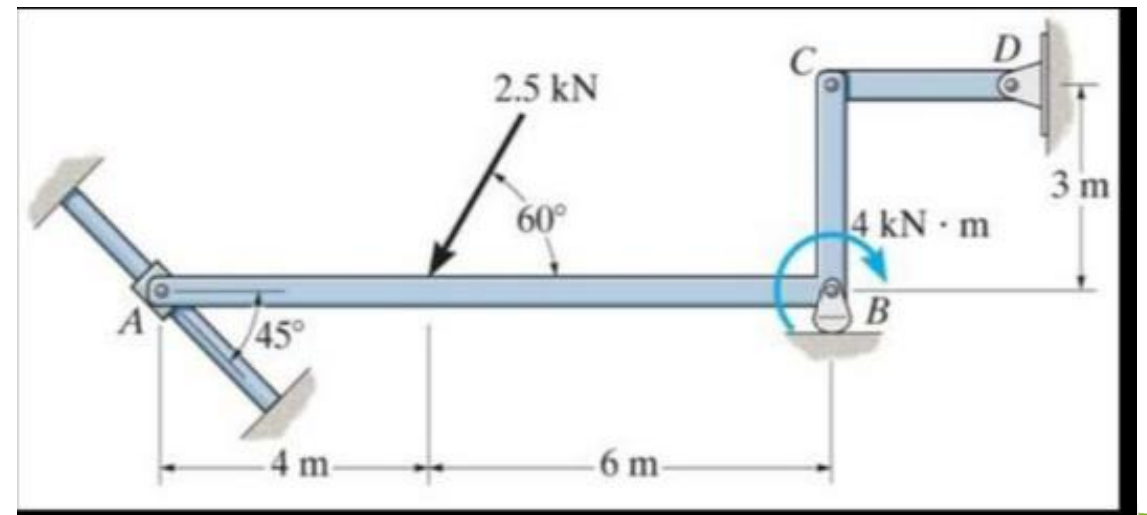
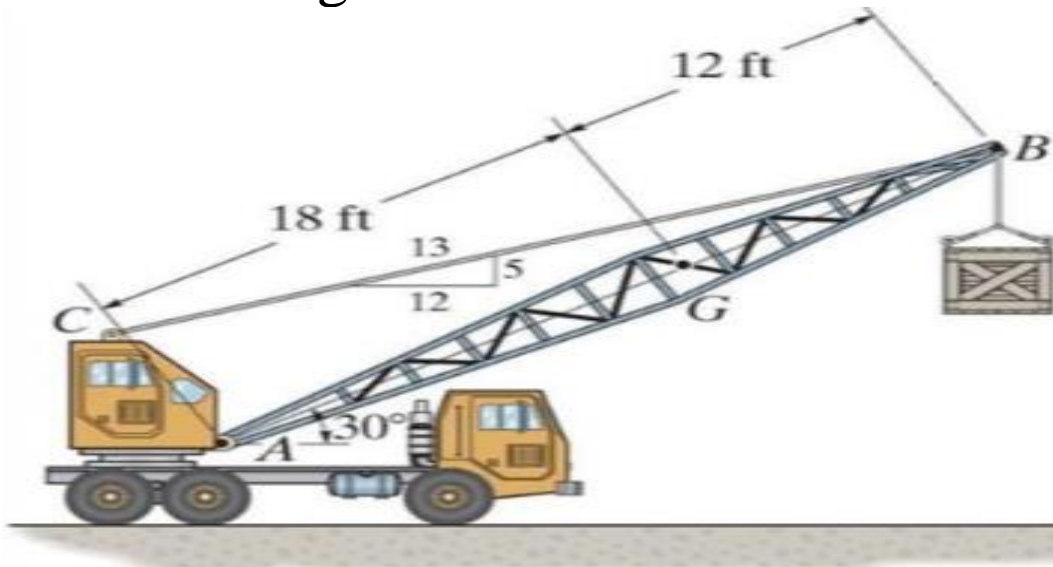

FREE BODY DIAGRAM (2D)

Example 5.4

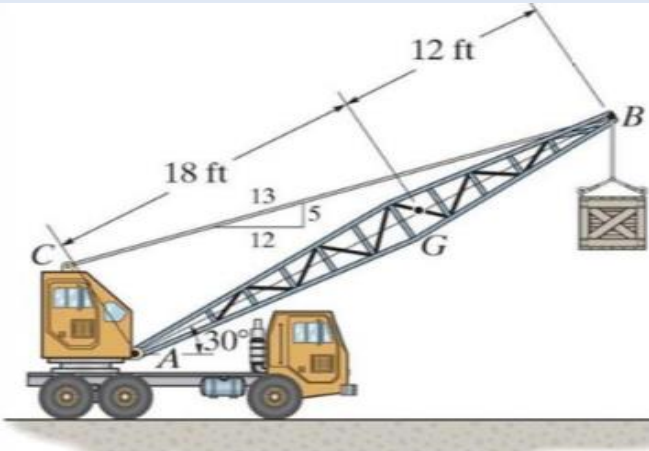

Solutions (a)

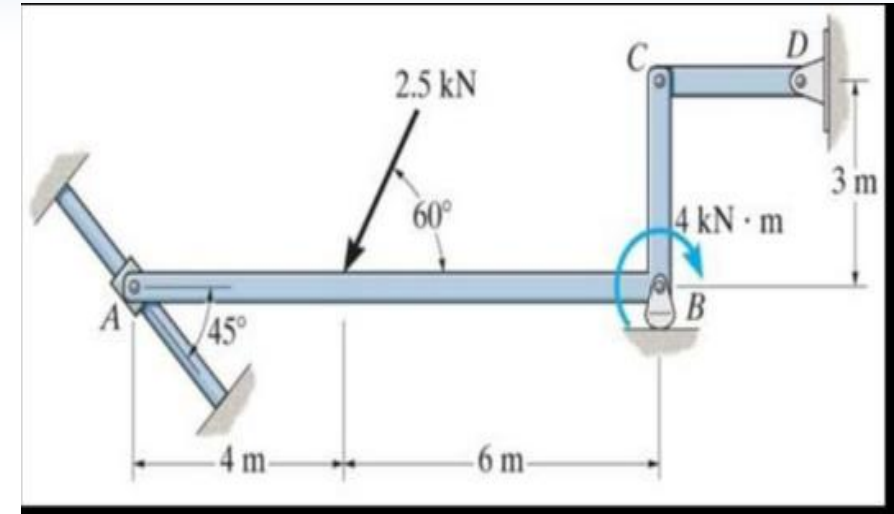
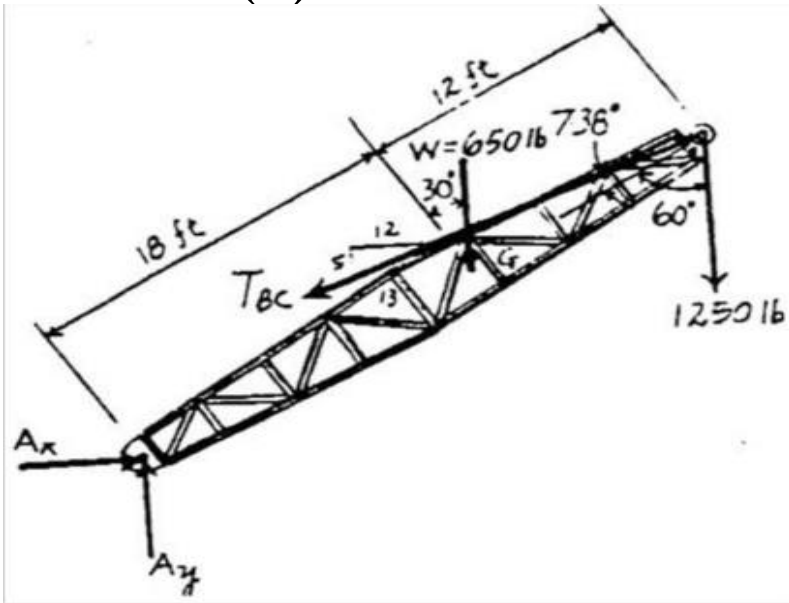

Solutions (b)

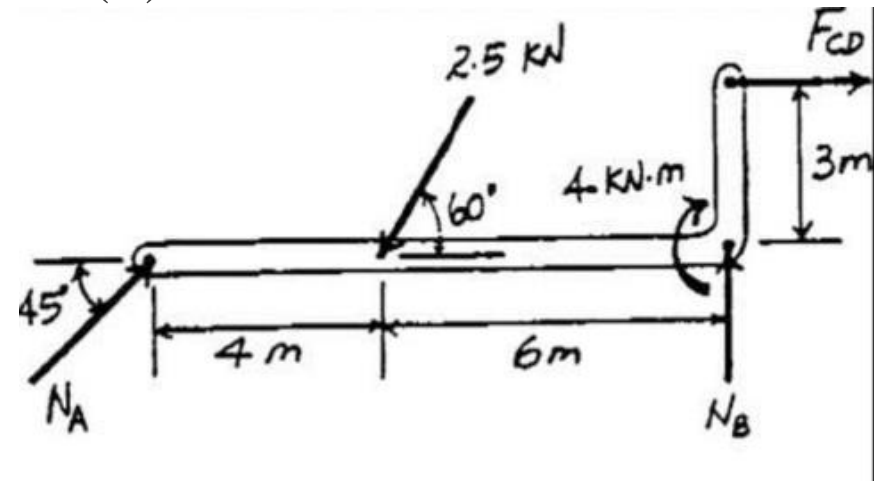



EQUILIBRIUM CONDITION(2D)

- We defined equilibrium as the condition in which the resultant of all forces and moments acting on a body is zero
- Or a body is in equilibrium if all forces and moments applied to it are in balance.
- These requirements are contained in the vector equations of equilibrium, which in two dimensions may be written in scalar form as

$$\sum F_x = 0, \sum F_y = 0, \& \sum M_0 = 0$$

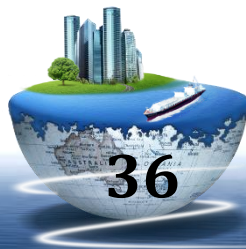

EQUILIBRIUM CONDITION(2D)

Categories of Equilibrium

- The categories of force systems acting on bodies in two-dimensional equilibrium are summarized into 4 categories.

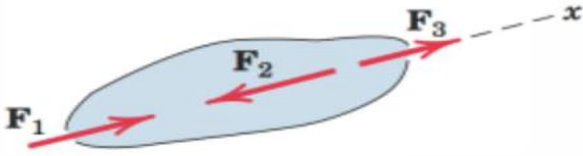
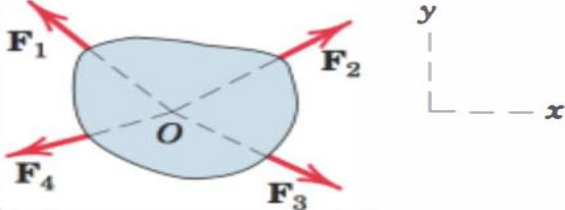
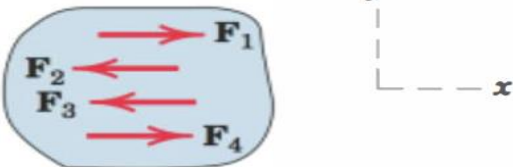
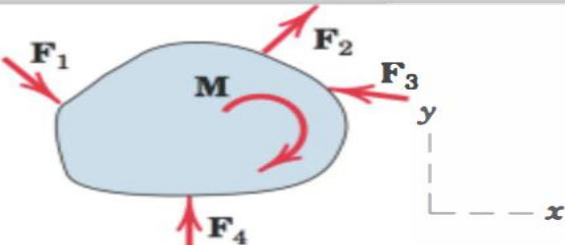
CATEGORIES OF EQUILIBRIUM IN TWO DIMENSIONS		
Force System	Free-Body Diagram	Independent Equations
1. Collinear		$\Sigma F_x = 0$
2. Concurrent at a point		$\Sigma F_x = 0$ $\Sigma F_y = 0$
3. Parallel		$\Sigma F_x = 0$ $\Sigma M_z = 0$
4. General		$\Sigma F_x = 0$ $\Sigma M_z = 0$ $\Sigma F_y = 0$

EQUILIBRIUM CONDITION(2D)

Alternative Sets of Equilibrium Equations

- Although $\sum F_x = 0$, $\sum F_y = 0$, & $\sum M_0 = 0$, are most often used for solving coplanar equilibrium problems,
- two alternative sets of three independent equilibrium equations may also be used.
- One such set is $\sum F_x = 0$, $\sum M_A = 0$, & $\sum M_B = 0$,
- And the 2nd $\sum M_A = 0$, $\sum M_B = 0$, & $\sum M_C = 0$,
- Prove the above alternative sets of equations

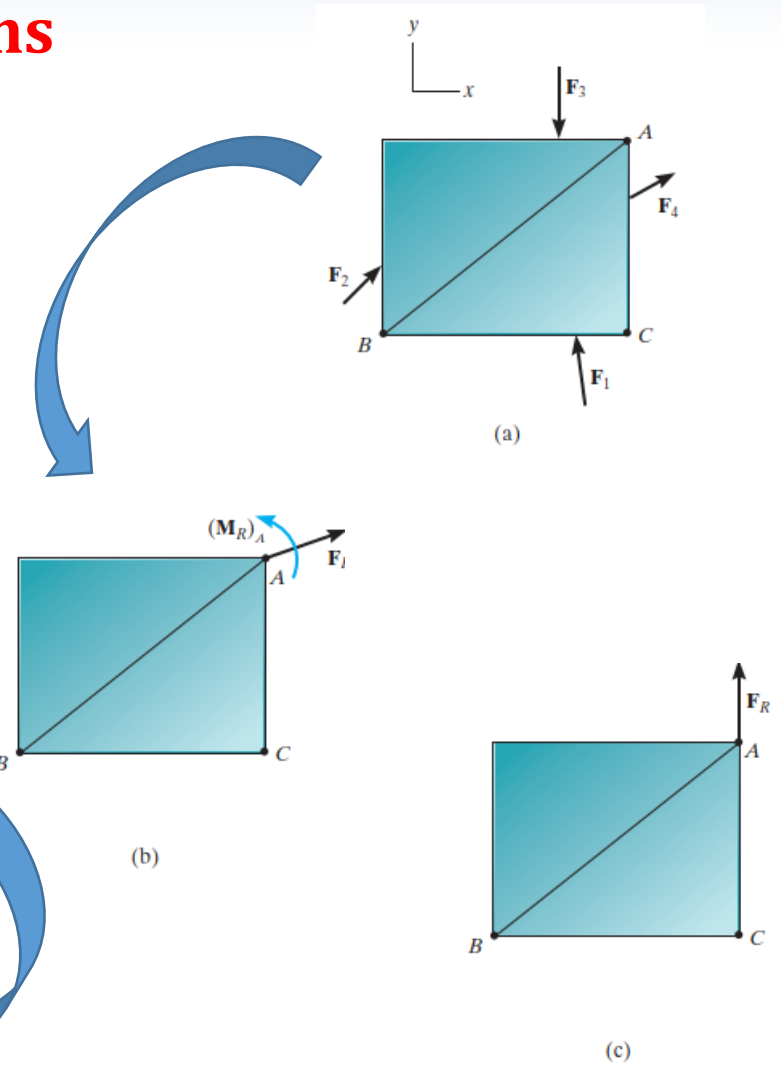
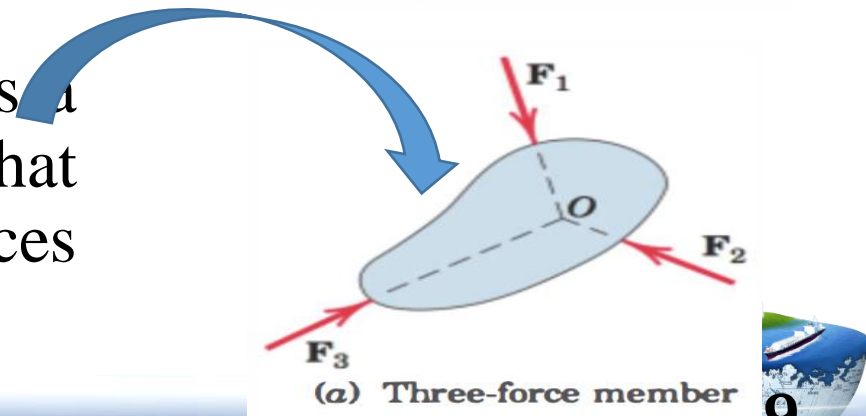
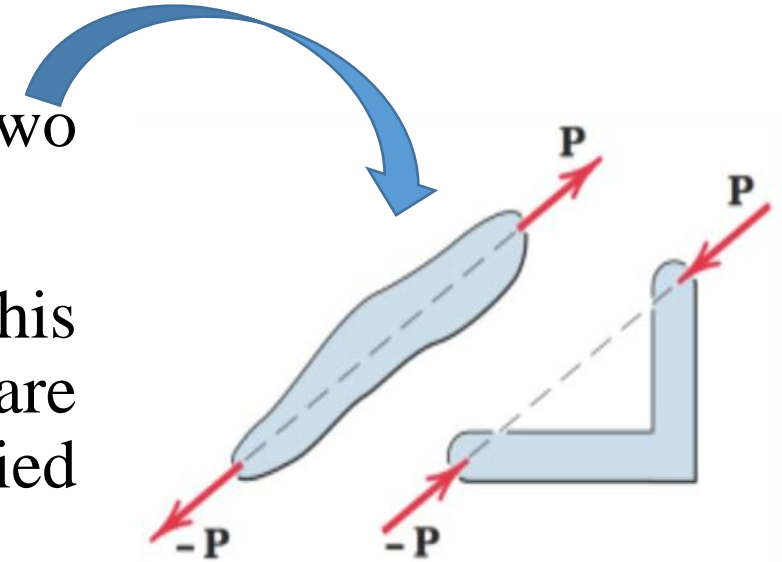

Fig. 5-11

EQUILIBRIUM CONDITION(2D) Two- and Three-Force Members

- Conditions for a body to be in equilibrium under two forces, are forces must be equal, opposite, and collinear.
- And note that the shape of the member does not affect this simple requirement and the weights of the members are assumed to be negligible compared with the applied forces.
- The second situation is a three-force member, which is a body under the action of three forces. We see that equilibrium requires the lines of action of the three forces to be concurrent



EQUILIBRIUM CONDITION(2D) Two- and Three-Force Members

- If they were not concurrent, then one of the forces would exert a resultant moment about the point of intersection of the other two, which would violate the requirement of zero moment about every point.
- **The only exception occurs when the three forces are parallel.**
- In this case we may consider the point of concurrency to be at infinity.

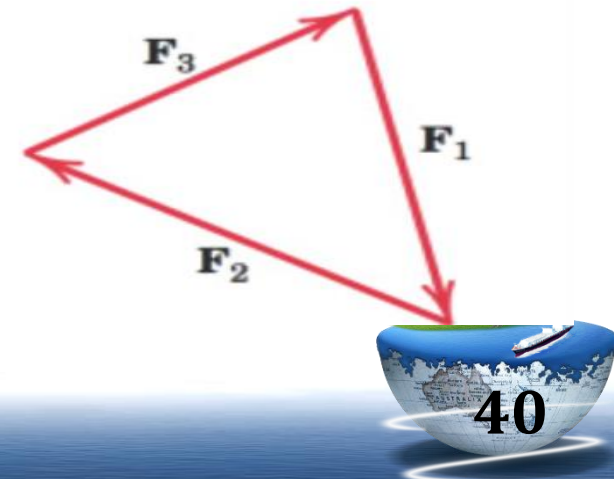
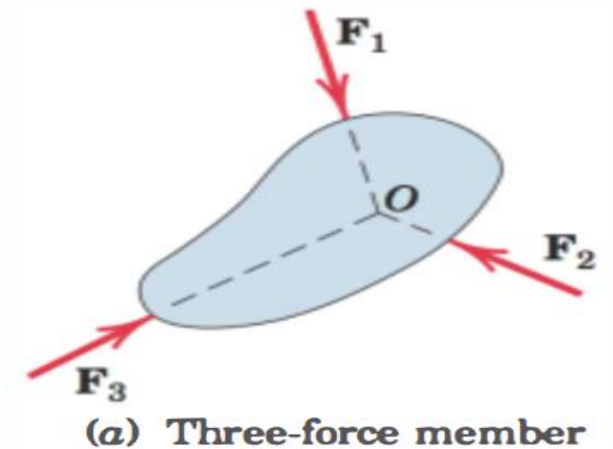



EQUILIBRIUM CONDITION (2D)

Constraints and Statically Determinacy

- The equilibrium equations shown in this lecture are both necessary and sufficient conditions to establish the equilibrium of a body.
- However, they do not necessarily provide all the information required to calculate all the unknown forces which may act on a body in equilibrium.
- The equations' adequacy to determine all the unknowns depends on the characteristics of the constraints against possible movement of the body provided by its supports.
- By constraint we mean the restriction of movement.





EQUILIBRIUM CONDITION (2D)

Constraints and Statically Determinacy

- A rigid body, or rigid combination of elements treated as a single body, which possesses more external supports or constraints than are necessary to maintain an equilibrium position is called **statically indeterminate**.
- Supports which can be removed without destroying the equilibrium condition of the body are said to be **redundant**.
- The number of redundant supporting elements present corresponds to the degree of statically indeterminacy and equals the total number of unknown external forces, minus the number of available independent equations of equilibrium.





EQUILIBRIUM CONDITION (2D)

Constraints and Statically Determinacy

- Bodies which are supported by the minimum number of constraints necessary to ensure an equilibrium configuration are called **statically determinate**, and for such bodies the equilibrium equations are sufficient to determine the unknown external forces.
- We must be aware of the nature of the constraints before we attempt to solve an equilibrium problem. A body can be recognized as statically indeterminate when there are more unknown external reactions than there are available independent equilibrium equations for the force system involved.
- It is always well to count the number of unknown variables on a given body and to be certain that an equal number of independent equations can be written; otherwise, effort might be wasted in attempting an impossible solution with the aid of the equilibrium equations only.



EQUILIBRIUM CONDITION (2D)

Statically Indeterminate Reactions

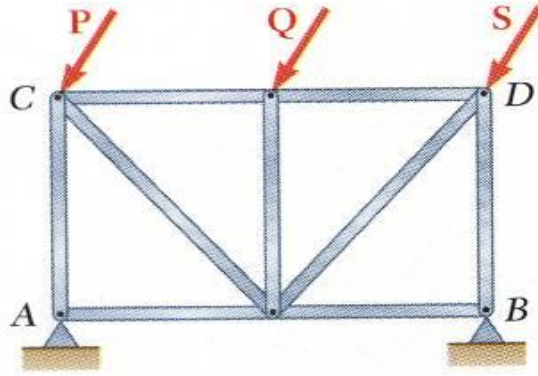

(a)

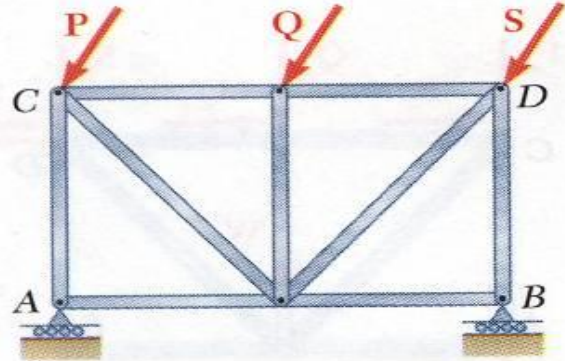

(a)

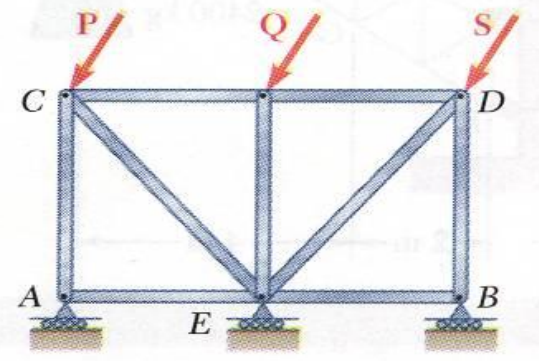

(a)

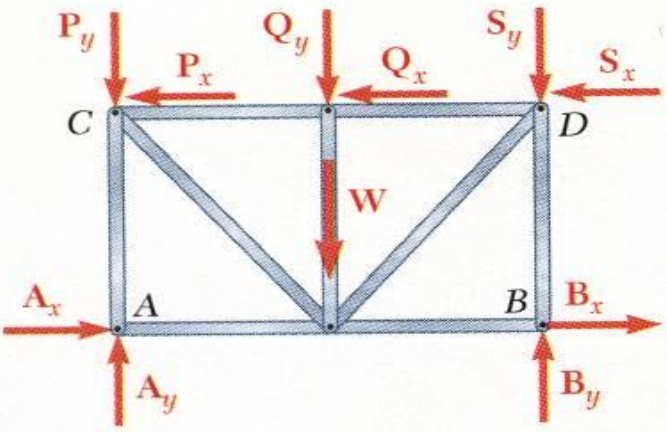

(b)

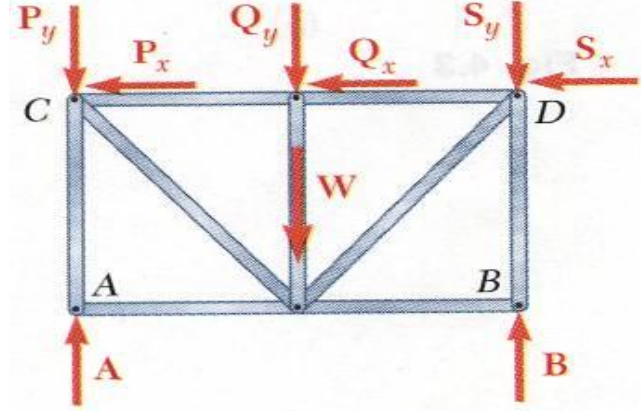

(b)

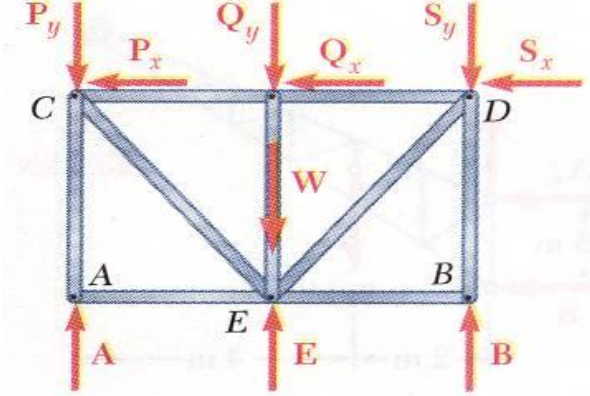

(b)

- More unknowns than equations

- Fewer unknowns than equations, partially constrained

- Equal number unknowns and equations but improperly constrained

FREE BODY DIAGRAM (2D)

Example 5.5

Question

- Determine the magnitudes of the forces C and T , which, along with the other three forces shown, act on the bridge-truss joint.

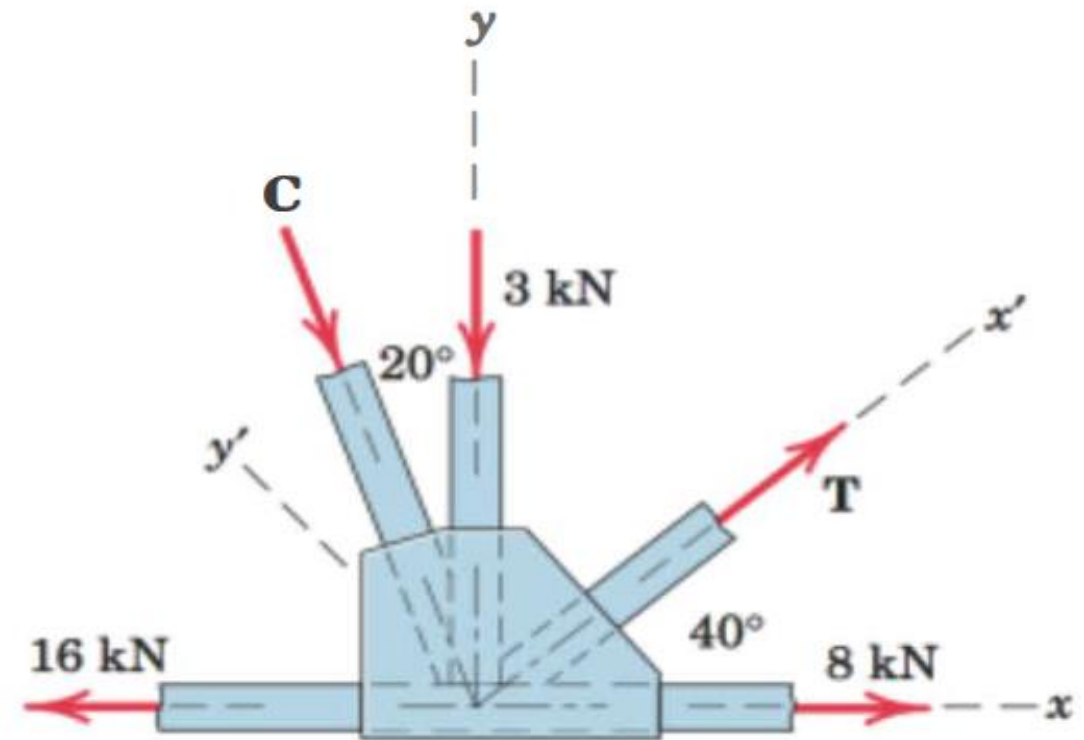

FREE BODY DIAGRAM (2D)

Example 5.5

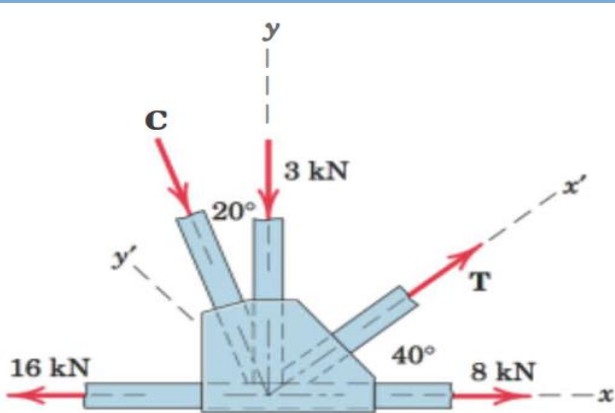

Solutions

The given sketch constitutes the free-body diagram of the isolated section of the joint in question and shows the five forces which are in equilibrium.

Solution I (scalar algebra). For the x - y axes as shown we have

$$[\Sigma F_x = 0] \quad 8 + T \cos 40^\circ + C \sin 20^\circ - 16 = 0$$

$$0.766T + 0.342C = 8 \quad (a)$$

$$[\Sigma F_y = 0] \quad T \sin 40^\circ - C \cos 20^\circ - 3 = 0$$

$$0.643T - 0.940C = 3 \quad (b)$$

Simultaneous solution of Eqs. (a) and (b) produces

$$T = 9.09 \text{ kN} \quad C = 3.03 \text{ kN} \quad \text{Ans.}$$

Solution II (scalar algebra). To avoid a simultaneous solution, we may use axes x' - y' with the first summation in the y' -direction to eliminate reference to T . Thus,

$$[\Sigma F_{y'} = 0] \quad -C \cos 20^\circ - 3 \cos 40^\circ - 8 \sin 40^\circ + 16 \sin 40^\circ = 0$$

$$C = 3.03 \text{ kN} \quad \text{Ans.}$$

$$[\Sigma F_{x'} = 0] \quad T + 8 \cos 40^\circ - 16 \cos 40^\circ - 3 \sin 40^\circ - 3.03 \sin 20^\circ = 0$$

$$T = 9.09 \text{ kN} \quad \text{Ans.}$$

Solution III (vector algebra). With unit vectors i and j in the x - and y -directions, the zero summation of forces for equilibrium yields the vector equation

$$[\Sigma \mathbf{F} = \mathbf{0}] \quad 8\mathbf{i} + (T \cos 40^\circ)\mathbf{i} + (T \sin 40^\circ)\mathbf{j} - 3\mathbf{j} + (C \sin 20^\circ)\mathbf{i} - (C \cos 20^\circ)\mathbf{j} - 16\mathbf{i} = \mathbf{0}$$

Equating the coefficients of the i - and j -terms to zero gives

$$8 + T \cos 40^\circ + C \sin 20^\circ - 16 = 0$$

$$T \sin 40^\circ - 3 - C \cos 20^\circ = 0$$

which are the same, of course, as Eqs. (a) and (b), which we solved above.



FREE BODY DIAGRAM (2D)

Example 5.6

Question

- Calculate the tension T in the cable which supports the 500-kg mass with the pulley arrangement shown. Each pulley is free to rotate about its bearing, and the weights of all parts are small compared with the load. Find the magnitude of the total force on the bearing of pulley C.

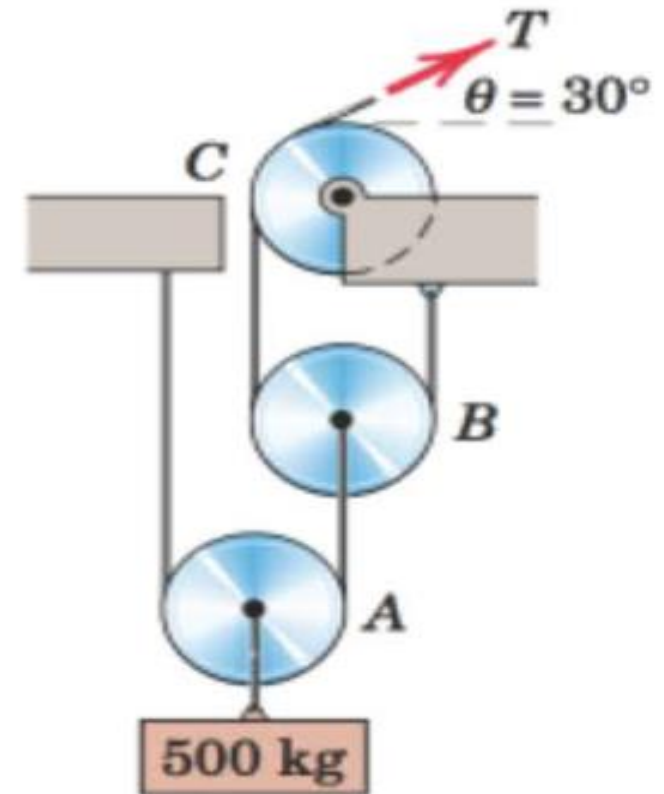

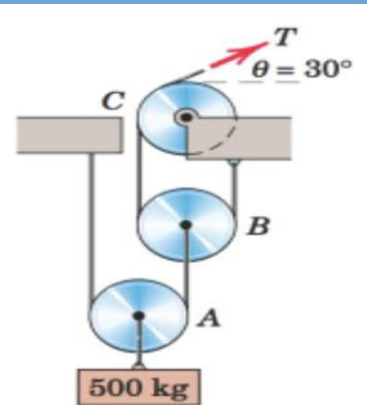

Solutions

The FBD of each pulley is drawn in its relative position to the others. We begin with pulley A, which includes the only known force.

With the unspecified pulley radius designated by r , the equilibrium of moments about its center O and the equilibrium of forces in the vertical direction require

FREE BODY DIAGRAM (2D)

Example 5.6

$$[\Sigma M_O = 0] \quad T_1 r - T_2 r = 0 \quad T_1 = T_2$$

$$[\Sigma F_y = 0] \quad T_1 + T_2 - 500(9.81) = 0 \quad 2T_1 = 500(9.81) \quad T_1 = T_2 = 2450 \text{ N}$$

From the example of pulley A we may write the equilibrium of forces on pulley B by inspection as

$$T_3 = T_4 = T_2/2 = 1226 \text{ N}$$

For pulley C the angle $\theta = 30^\circ$ in no way affects the moment of T about the center of the pulley, so that moment equilibrium requires

$$T = T_3 \quad \text{or} \quad T = 1226 \text{ N} \quad \text{Ans.}$$

Equilibrium of the pulley in the x - and y -directions requires

$$[\Sigma F_x = 0] \quad 1226 \cos 30^\circ - F_x = 0 \quad F_x = 1062 \text{ N}$$

$$[\Sigma F_y = 0] \quad F_y + 1226 \sin 30^\circ - 1226 = 0 \quad F_y = 613 \text{ N}$$

$$[F = \sqrt{F_x^2 + F_y^2}] \quad F = \sqrt{(1062)^2 + (613)^2} = 1226 \text{ N} \quad \text{Ans.}$$

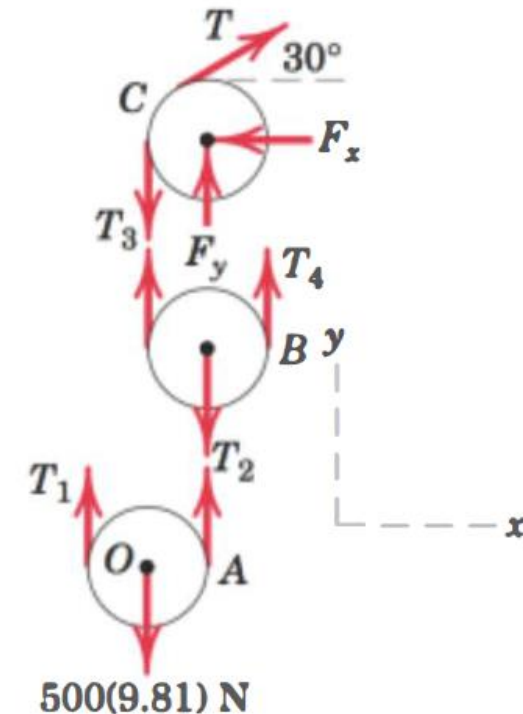

FREE BODY DIAGRAM (2D)

Example 5.7

Question

- The uniform 100-kg 1-beam is supported initially by its end rollers on the horizontal surface at A and B. By means of the cable at C, it is desired to elevate end B to a position 3 m above end A. Determine the required tension P , the reaction at A, and the angle θ made by the beam with the horizontal in the elevated position.

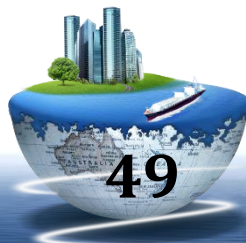
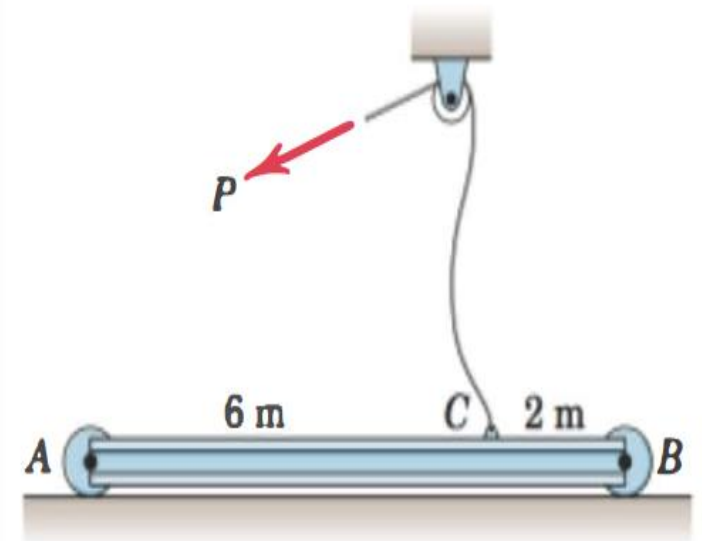

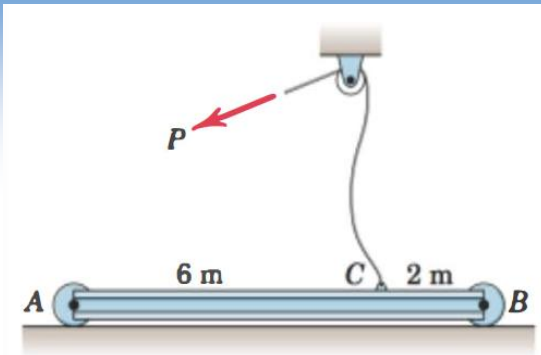

FREE BODY DIAGRAM (2D)

Example 5.7

Solutions

In constructing the free-body diagram, we note that the reaction on the roller at A and the weight are vertical forces. Consequently, in the absence of other horizontal forces, P must also be vertical.

Moment equilibrium about A eliminates force R and gives

$$[\Sigma M_A = 0] \quad P(6 \cos \theta) - 981(4 \cos \theta) = 0 \quad P = 654 \text{ N} \quad \text{Ans.}$$

Equilibrium of vertical forces requires

$$[\Sigma F_y = 0] \quad 654 + R - 981 = 0 \quad R = 327 \text{ N} \quad \text{Ans.}$$

The angle θ depends only on the specified geometry and is

$$\sin \theta = 3/8 \quad \theta = 22.0^\circ \quad \text{Ans.}$$

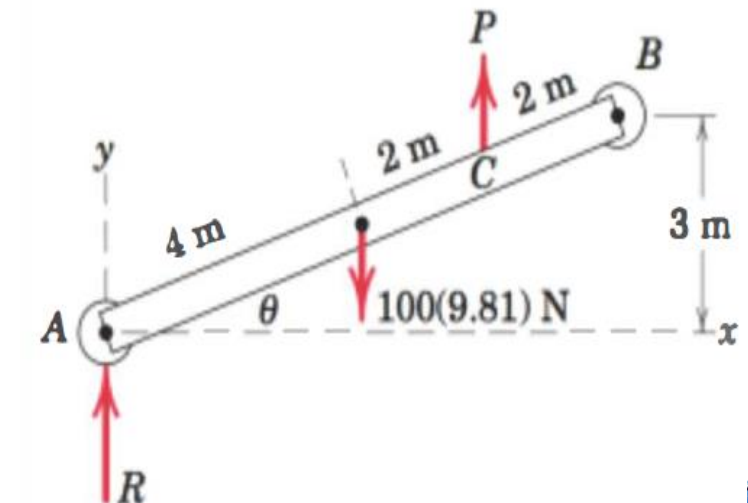

FREE BODY DIAGRAM (2D)

Example 5.8

Question

- Determine the magnitude T of the tension in the supporting cable and the magnitude of the force on the pin at A for the jib crane shown. The beam AB is a standard 0.5-m I-beam with a mass of 95 kg per meter of length.

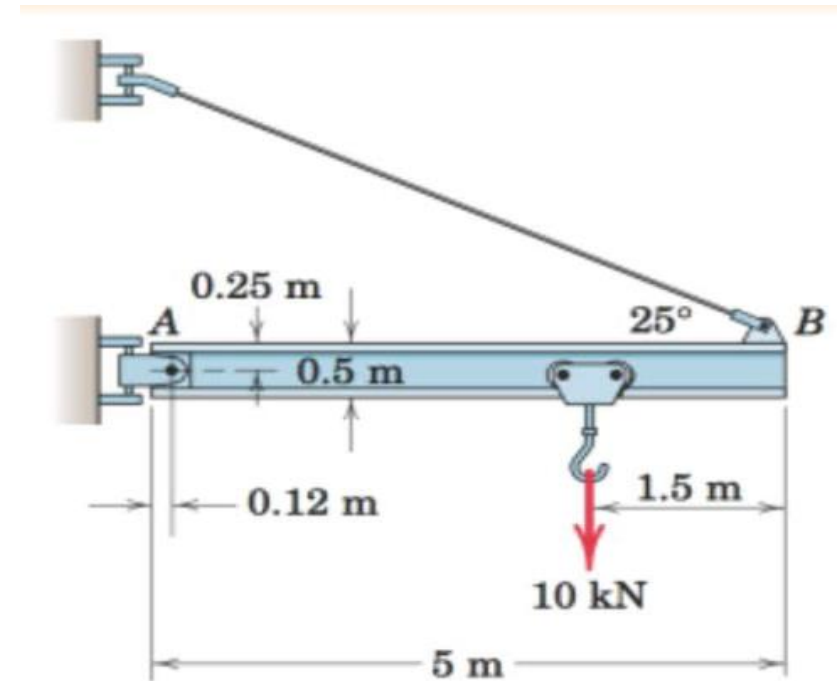

FREE BODY DIAGRAM (2D)

Example 5.8

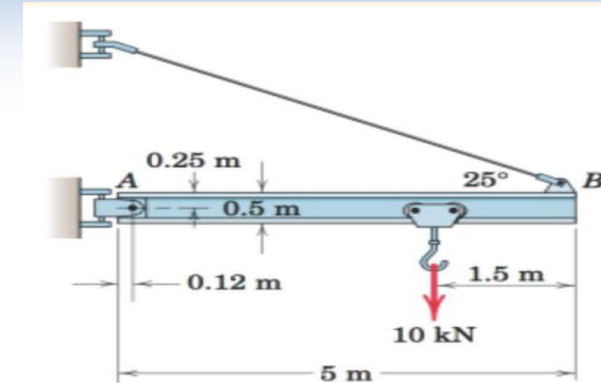

Solutions

The system is symmetrical about the vertical :N-Y plane through the center of the beam, so the problem may be analyzed as the equilibrium of a coplanar force system.

$$[\Sigma M_A = 0] \quad (T \cos 25^\circ)0.25 + (T \sin 25^\circ)(5 - 0.12) - 10(5 - 1.5 - 0.12) - 4.66(2.5 - 0.12) = 0$$

from which $T = 19.61 \text{ kN}$ *Ans.*

Equating the sums of forces in the x - and y -directions to zero gives

$$[\Sigma F_x = 0] \quad A_x - 19.61 \cos 25^\circ = 0 \quad A_x = 17.77 \text{ kN}$$

$$[\Sigma F_y = 0] \quad A_y + 19.61 \sin 25^\circ - 4.66 - 10 = 0 \quad A_y = 6.37 \text{ kN}$$

$$[A = \sqrt{A_x^2 + A_y^2}] \quad A = \sqrt{(17.77)^2 + (6.37)^2} = 18.88 \text{ kN} \quad \text{Ans.}$$

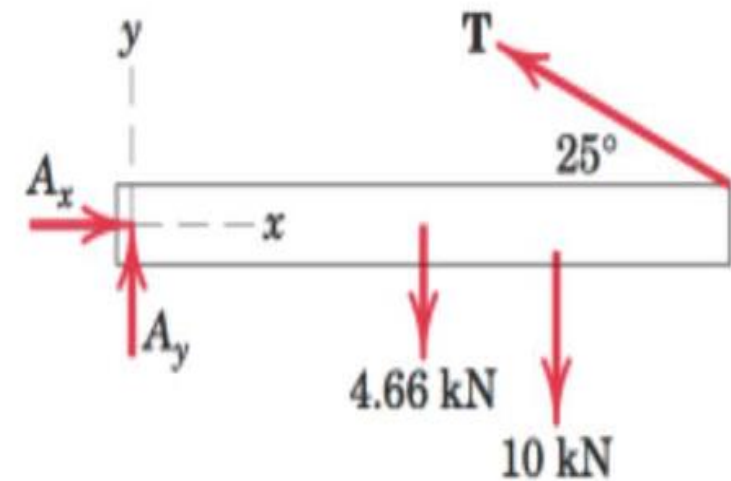

Free-body diagram



EQUILIBRIUM IN 3D

Equilibrium Conditions

$$\Sigma \mathbf{F} = \Sigma F_x \mathbf{i} + \Sigma F_y \mathbf{j} + \Sigma F_z \mathbf{k} = \mathbf{0}$$
$$\Sigma \mathbf{M}_O = \Sigma M_x \mathbf{i} + \Sigma M_y \mathbf{j} + \Sigma M_z \mathbf{k} = \mathbf{0}$$

- We now extend our principles and methods developed for 2D equilibrium to the case of 3D equilibrium.
- In general the conditions for the equilibrium of a body require that the resultant force and resultant couple on a body in equilibrium be zero.
- These two vector equations of equilibrium and their scalar components may be written as

$$\Sigma \mathbf{F} = \mathbf{0} \quad \text{or} \quad \begin{cases} \Sigma F_x = 0 \\ \Sigma F_y = 0 \\ \Sigma F_z = 0 \end{cases}$$
$$\Sigma \mathbf{M} = \mathbf{0} \quad \text{or} \quad \begin{cases} \Sigma M_x = 0 \\ \Sigma M_y = 0 \\ \Sigma M_z = 0 \end{cases}$$

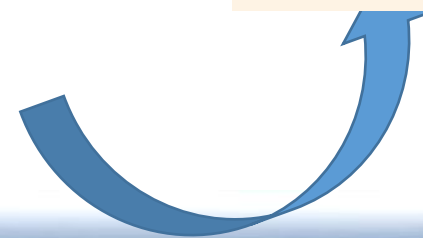



$$\Sigma \mathbf{M} = 0 \quad \text{or} \quad \begin{cases} \Sigma M_x = 0 \\ \Sigma M_y = 0 \\ \Sigma M_z = 0 \end{cases}$$

EQUILIBRIUM IN 3D

Equilibrium Conditions

$$\Sigma \mathbf{F} = 0 \quad \text{or} \quad \begin{cases} \Sigma F_x = 0 \\ \Sigma F_y = 0 \\ \Sigma F_z = 0 \end{cases}$$

- The 3 eqns state that there is no resultant force acting on a body in equilibrium in any of the three coordinate directions & the second 3 eqns state that the resultant moment acting on the body about any of the coordinate axes or about axes parallel to the coordinate axes is ZERO.
- These six equations are both necessary and sufficient conditions for complete equilibrium.
- The reference axes may be chosen arbitrarily as a matter of convenience, the only restriction being that a right-handed coordinate system should be chosen when vector notation is used.



FREE BODY DIAGRAM 3D

Equilibrium Conditions

- The general procedure for establishing the FBD of a rigid body has been outlined already in the previous slides.
- Essentially it requires first “isolating” the body by drawing its outlined shape.
- This is followed by a careful labelling of all the forces and couple moments with reference to an established x, y, z coordinate system.
- As a general rule, it is suggested to show the unknown components of reaction as acting on the free-body diagram in the positive sense.
- In this way, if any negative values are obtained, they will indicate that the components act in the negative coordinate directions.

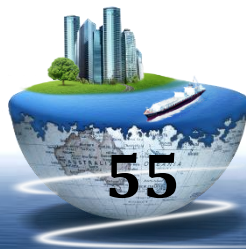

FREE BODY DIAGRAM (3D)







Modeling the Action of Forces (Support Reactions)





MODELING THE ACTION OF FORCES IN THREE-DIMENSIONAL ANALYSIS	
Type of Contact and Force Origin	Action on Body to Be Isolated
<p>1. Member in contact with smooth surface, or ball-supported member</p>	<p>Force must be normal to the surface and directed toward the member.</p>
<p>2. Member in contact with rough surface</p>	<p>The possibility exists for a force F tangent to the surface (friction force) to act on the member, as well as a normal force N.</p>
<p>3. Roller or wheel support with lateral constraint</p>	<p>A lateral force P exerted by the guide on the wheel can exist, in addition to the normal force N.</p>
<p>4. Ball-and-socket joint</p>	<p>A ball-and-socket joint free to pivot about the center of the ball can support a force \mathbf{R} with all three components.</p>
<p>5. Fixed connection (embedded or welded)</p>	<p>In addition to three components of force, a fixed connection can support a couple \mathbf{M} represented by its three components.</p>
<p>6. Thrust-bearing support</p>	<p>Thrust bearing is capable of supporting axial force R_y as well as radial forces R_x and R_z. Couples M_x and M_z must, in some cases, be assumed zero in order to provide statical determinacy.</p>

FREE BODY DIAGRAM (3D)

Modeling the Action of Forces (With No. of Unknowns)

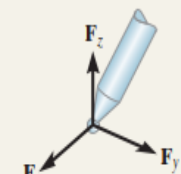
TABLE 5–2 Supports for Rigid Bodies Subjected to Three-Dimensional Force Systems

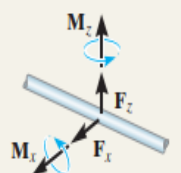
Types of Connection	Reaction	Number of Unknowns
(1)  cable		One unknown. The reaction is a force which acts away from the member in the known direction of the cable.
(2)  smooth surface support		One unknown. The reaction is a force which acts perpendicular to the surface at the point of contact.
(3)  roller		One unknown. The reaction is a force which acts perpendicular to the surface at the point of contact.

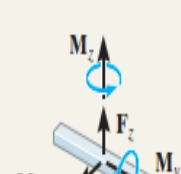
(4)  ball and socket		Three unknowns. The reactions are three rectangular force components.
(5)  single journal bearing		Four unknowns. The reactions are two force and two couple-moment components which act perpendicular to the shaft. Note: The couple moments are <i>generally not applied</i> if the body is supported elsewhere. See the examples.
(6)  single journal bearing with square shaft		Five unknowns. The reactions are two force and three couple-moment components. Note: The couple moments are <i>generally not applied</i> if the body is supported elsewhere. See the examples.

FREE BODY DIAGRAM (3D)

Modeling the Action of Forces (With No. of Unknowns)

TABLE 5-2 Continued

Types of Connection

Reaction

Number of Unknowns

(7)



single thrust bearing

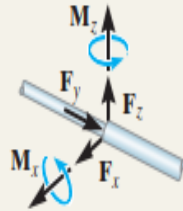

Five unknowns. The reactions are three force and two couple-moment components. *Note:* The couple moments are generally not applied if the body is supported elsewhere. See the examples.

(8)



single smooth pin

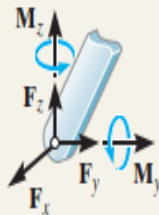

Five unknowns. The reactions are three force and two couple-moment components. *Note:* The couple moments are generally not applied if the body is supported elsewhere. See the examples.

TABLE 5-2 Continued

Types of Connection

Reaction

Number of Unknowns

(9)



single hinge

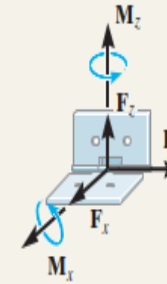

Five unknowns. The reactions are three force and two couple-moment components. *Note:* The couple moments are generally not applied if the body is supported elsewhere. See the examples.

(10)



fixed support

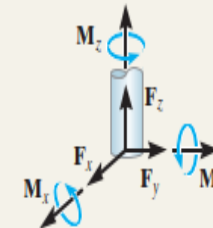

Six unknowns. The reactions are three force and three couple-moment components.

FREE BODY DIAGRAM (3D) Modeling the Action of Forces (Support Reactions)

- Typical examples of connections and reactions in 3D



This ball-and-socket joint provides a connection for the housing of an earth grader to its frame. (4) (© Russell C Hibbeler)



This pin is used to support the end of the strut used on a tractor. (8) (© Russell C. Hibbeler)



The journal bearings support the ends of the shaft. (5) (© Russell C. Hibbeler)



This thrust bearing is used to support the drive shaft on a machine. (7) (© Russell C. Hibbeler)

EQUILIBRIUM CONDITION (3D)

Categories of Equilibrium

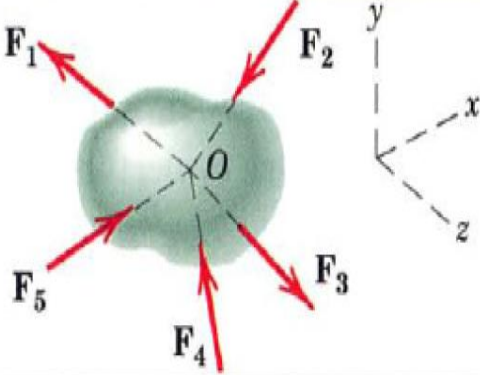
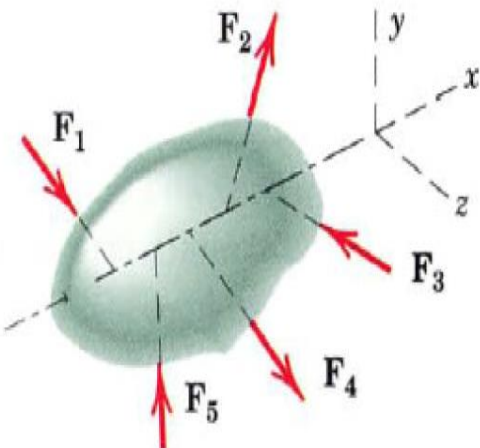
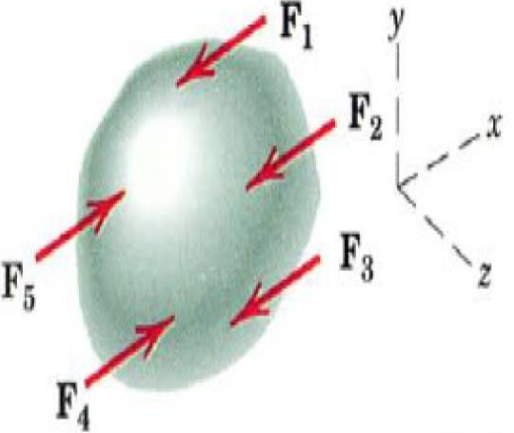
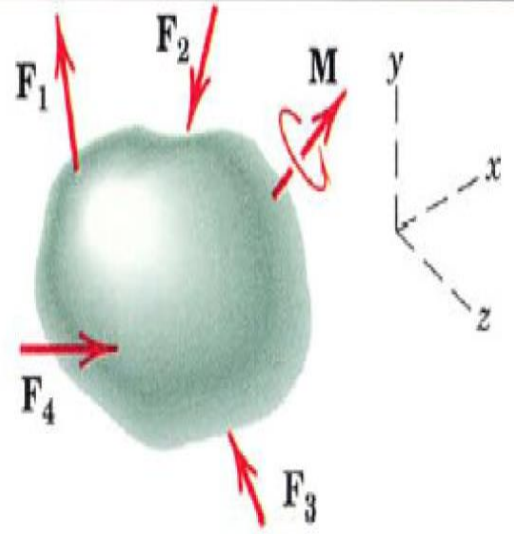
CATEGORIES OF EQUILIBRIUM IN THREE DIMENSIONS		
Force System	Free-Body Diagram	Independent Equations
1. Concurrent at a point		$\Sigma F_x = 0$ $\Sigma F_y = 0$ $\Sigma F_z = 0$
2. Concurrent with a line		$\Sigma F_x = 0 \quad \Sigma M_y = 0$ $\Sigma F_y = 0 \quad \Sigma M_z = 0$ $\Sigma F_z = 0$
3. Parallel		$\Sigma F_x = 0 \quad \Sigma M_y = 0$ $\Sigma M_z = 0$
4. General		$\Sigma F_x = 0 \quad \Sigma M_x = 0$ $\Sigma F_y = 0 \quad \Sigma M_y = 0$ $\Sigma F_z = 0 \quad \Sigma M_z = 0$





$$\Sigma \mathbf{M} = 0 \quad \text{or} \quad \begin{cases} \Sigma M_x = 0 \\ \Sigma M_y = 0 \\ \Sigma M_z = 0 \end{cases}$$

EQUILIBRIUM CONDITION (3D)
Constraints and Statically Determinacy

$$\Sigma \mathbf{F} = 0 \quad \text{or} \quad \begin{cases} \Sigma F_x = 0 \\ \Sigma F_y = 0 \\ \Sigma F_z = 0 \end{cases}$$

- The six eqns, although necessary and sufficient conditions to establish equilibrium, do not necessarily provide all of the information required to calculate the unknown forces acting in a 3D equilibrium situation.
- Again, as we found with 2D, the question of adequacy of information is decided by the characteristics of the constraints provided by the supports.
- Some bodies may have more supports than are necessary for equilibrium, whereas others may not have enough or the supports may be arranged in a particular manner that could cause the body to move.
- Each of these cases will briefly be discussed.



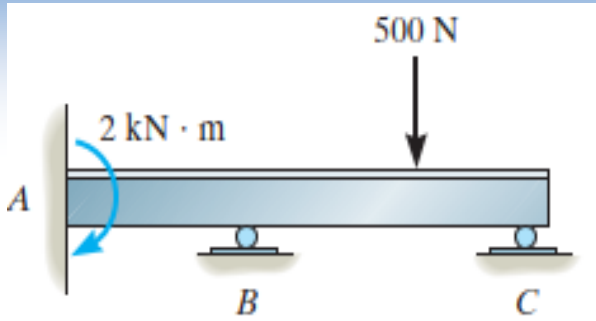

EQUILIBRIUM CONDITION (3D)

Constraints and Static Determinacy

1) Redundant Constraints.

- When a body has redundant supports, that is, more supports than are necessary to hold it in equilibrium, it becomes statically indeterminate. Statically indeterminate means that there will be more unknown loadings on the body than equations of equilibrium available for their solution.
- Therefore the additional equations needed to solve statically indeterminate problems are generally obtained from the deformation conditions at the points of support (mechanics of materials).

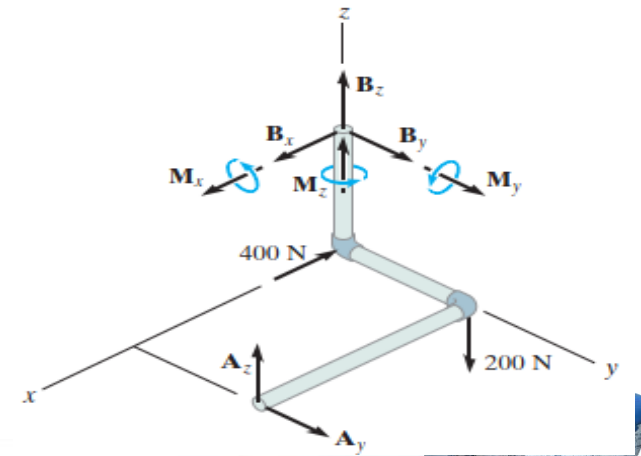
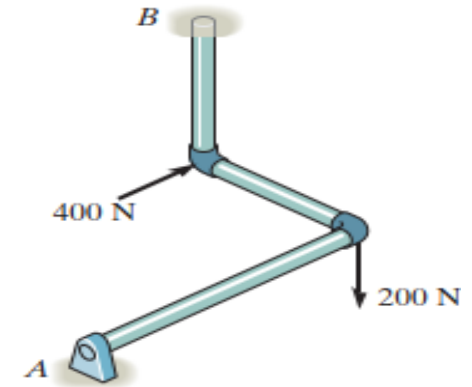
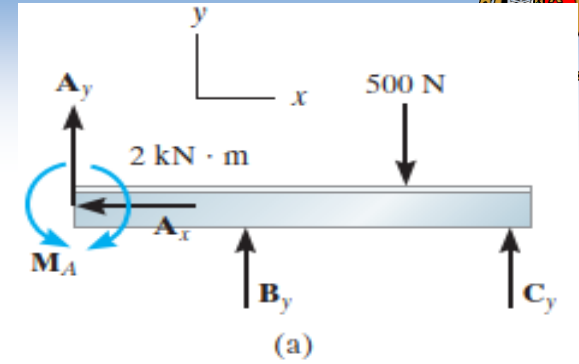

EQUILIBRIUM CONDITION (3D)

Constraints and Statically Determinacy

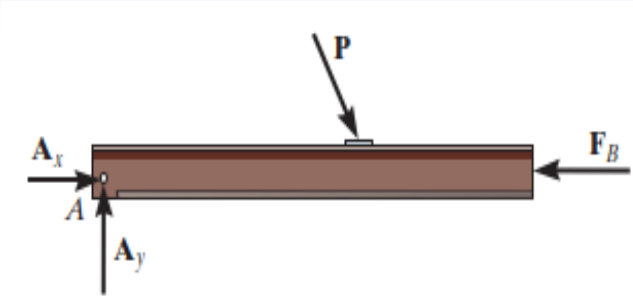
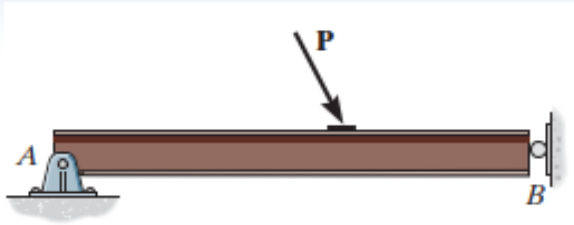

2) Improper Constraints.

- Having the same number of unknown reactive forces as available equations of equilibrium does not always guarantee that a body will be stable when subjected to a particular loading.
- For example, the pin support at A and the roller support at B for the beam in Fig. shown are placed in such a way that the lines of action of the reactive forces are concurrent at point A.
- Consequently, the applied loading P will cause the beam to rotate slightly about A, and so the beam is improperly constrained



EQUILIBRIUM CONDITION (3D)

Improper Constraints and Statically Determinacy

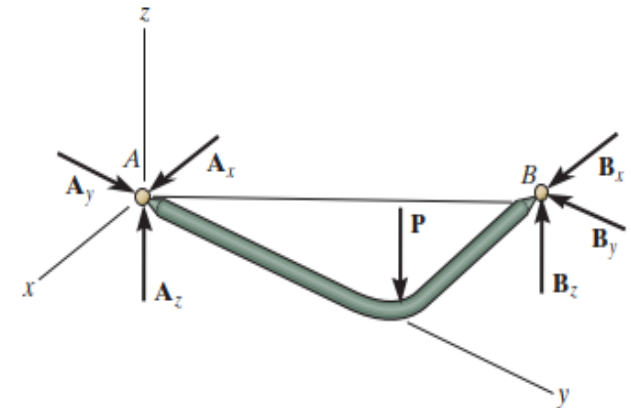
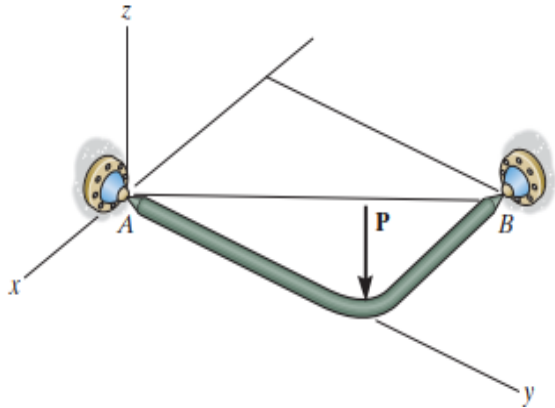

2) Improper Constraints.

- In 3D, a body will be improperly constrained if the lines of action of all the reactive forces intersect a common axis. For example, the reactive forces at the ball-and-socket supports at A and B in Fig. shown all intersect the axis passing through A and B.
- Since the moments of these forces about A and B are all zero, then the loading P will rotate the member about the AB axis.

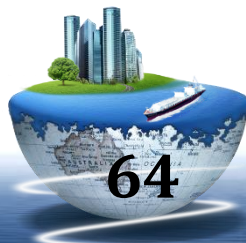

EQUILIBRIUM - FREE BODY DIAGRAM (3D)

Example 5.9

Question

- The uniform 7-m steel shaft has a mass of 200 kg and is supported by a ball and-socket joint at A in the horizontal floor. The ball end B rests against the smooth vertical walls as shown. Compute the forces exerted by the walls and the floor on the ends of the shaft.

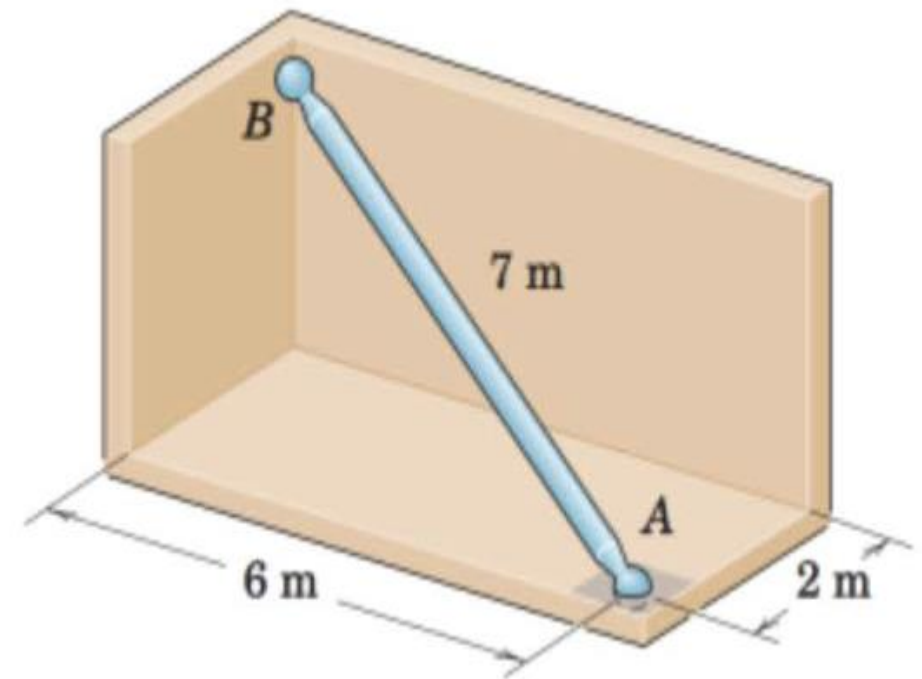

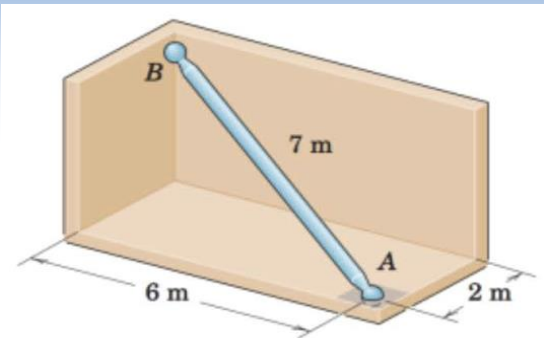

EQUILIBRIUM FREE BODY DIAGRAM (2D) Example 5.9

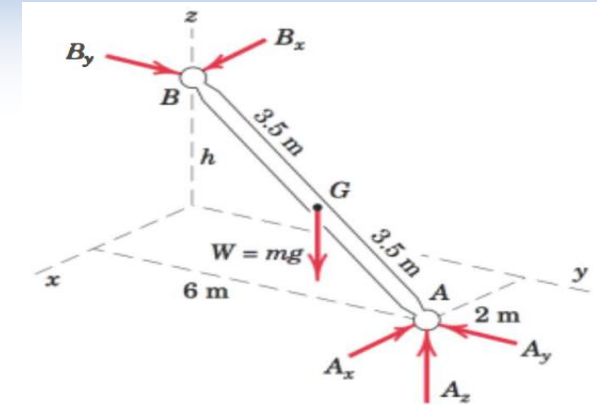

Solutions

Solution. The free-body diagram of the shaft is first drawn where the contact forces acting on the shaft at B are shown normal to the wall surfaces. In addition to the weight $W = mg = 200(9.81) = 1962 \text{ N}$, the force exerted by the floor on the ball joint at A is represented by its x -, y -, and z -components. These components are shown in their correct physical sense, as should be evident from the requirement that A be held in place. The vertical position of B is found from $7 = \sqrt{2^2 + 6^2 + h^2}$, $h = 3 \text{ m}$. Right-handed coordinate axes are assigned as shown.

Vector solution. We will use A as a moment center to eliminate reference to the forces at A . The position vectors needed to compute the moments about A are

$$\mathbf{r}_{AG} = -1\mathbf{i} - 3\mathbf{j} + 1.5\mathbf{k} \text{ m} \quad \text{and} \quad \mathbf{r}_{AB} = -2\mathbf{i} - 6\mathbf{j} + 3\mathbf{k} \text{ m}$$

where the mass center G is located halfway between A and B .

The vector moment equation gives

The vector moment equation gives

$$[\Sigma \mathbf{M}_A = 0] \quad \mathbf{r}_{AB} \times (\mathbf{B}_x + \mathbf{B}_y) + \mathbf{r}_{AG} \times \mathbf{W} = 0$$

$$(-2\mathbf{i} - 6\mathbf{j} + 3\mathbf{k}) \times (B_x\mathbf{i} + B_y\mathbf{j}) + (-1\mathbf{i} - 3\mathbf{j} + 1.5\mathbf{k}) \times (-1962\mathbf{k}) = 0$$

$$\begin{vmatrix} \mathbf{i} & \mathbf{j} & \mathbf{k} \\ -2 & -6 & 3 \\ B_x & B_y & 0 \end{vmatrix} + \begin{vmatrix} \mathbf{i} & \mathbf{j} & \mathbf{k} \\ -1 & -3 & 1.5 \\ 0 & 0 & -1962 \end{vmatrix} = 0$$

$$(-3B_y + 5890)\mathbf{i} + (3B_x - 1962)\mathbf{j} + (-2B_y + 6B_x)\mathbf{k} = 0$$

Equating the coefficients of \mathbf{i} , \mathbf{j} , and \mathbf{k} to zero and solving give

$$B_x = 654 \text{ N} \quad \text{and} \quad B_y = 1962 \text{ N} \quad \text{Ans.}$$

The forces at A are easily determined by

$$[\Sigma \mathbf{F} = 0] \quad (654 - A_x)\mathbf{i} + (1962 - A_y)\mathbf{j} + (-1962 + A_z)\mathbf{k} = 0$$

$$\text{and} \quad A_x = 654 \text{ N} \quad A_y = 1962 \text{ N} \quad A_z = 1962 \text{ N}$$

Finally,

$$A = \sqrt{A_x^2 + A_y^2 + A_z^2}$$

$$= \sqrt{(654)^2 + (1962)^2 + (1962)^2} = 2850 \text{ N} \quad \text{Ans.}$$

EQUILIBRIUM FREE BODY DIAGRAM (2D)

Example 5.9

Solutions equilibrium.

Scalar solution. Evaluating the scalar moment equations about axes through A parallel, respectively, to the x- and y-axes, gives

$$[\Sigma M_{A_x} = 0] \quad 1962(3) - 3B_y = 0 \quad B_y = 1962 \text{ N}$$

$$[\Sigma M_{A_y} = 0] \quad -1962(1) + 3B_x = 0 \quad B_x = 654 \text{ N}$$

The force equations give, simply,

$$[\Sigma F_x = 0] \quad -A_x + 654 = 0 \quad A_x = 654 \text{ N}$$

$$[\Sigma F_y = 0] \quad -A_y + 1962 = 0 \quad A_y = 1962 \text{ N}$$

$$[\Sigma F_z = 0] \quad A_z - 1962 = 0 \quad A_z = 1962 \text{ N}$$

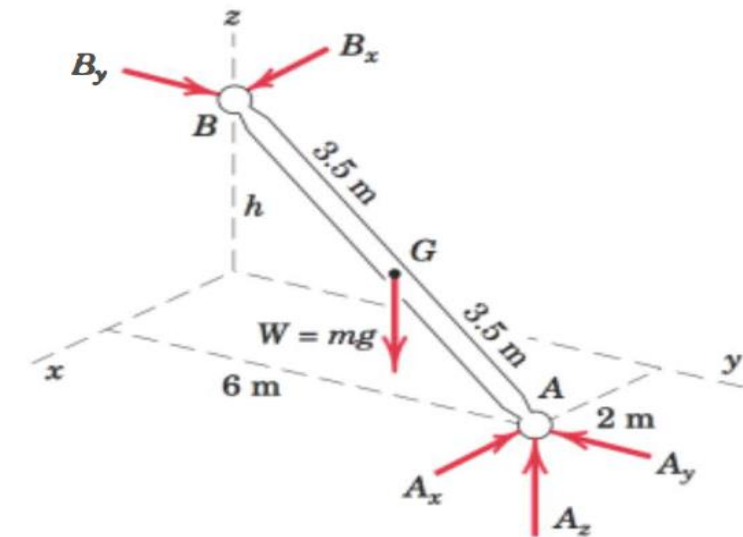
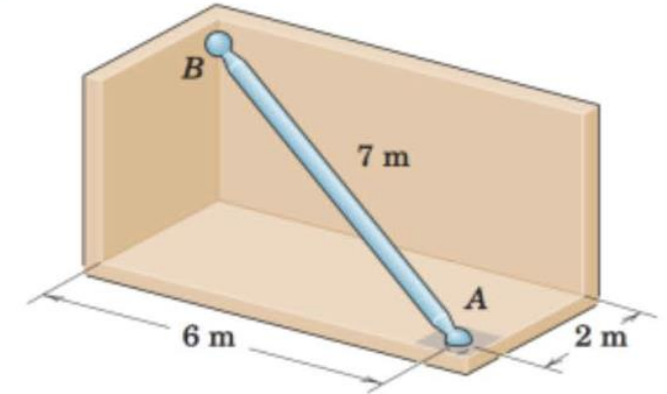

EQUILIBRIUM - FREE BODY DIAGRAM (3D)

Example 5.10

Question

• The welded tubular frame is secured to the horizontal x-y plane by a ball and-socket joint at A and receives support from the loose-fitting ring at B. Under the action of the 2-kN load, rotation about a line from A to B is prevented by the cable CD, and the frame is stable in the position shown. Neglect the weight of the frame compared with the applied load and determine the tension T in the cable, the reaction at the ring, and the reaction components at A.

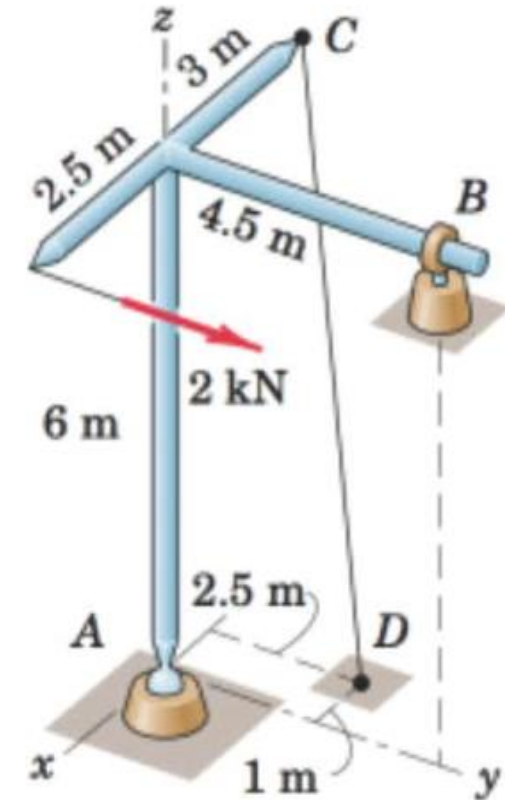

EQUILIBRIUM FREE BODY DIAGRAM (2D)

Example 5.10

Solutions

Solution. The system is clearly three-dimensional with no lines or planes of symmetry, and therefore the problem must be analyzed as a general space system of forces. The free-body diagram is drawn, where the ring reaction is shown in terms of its two components. All unknowns except T may be eliminated by a moment sum about the line AB . The direction of AB is specified by the unit vector $\mathbf{n} = \frac{1}{\sqrt{6^2 + 4.5^2}}(4.5\mathbf{j} + 6\mathbf{k}) = \frac{1}{5}(3\mathbf{j} + 4\mathbf{k})$. The moment of T about AB

is the component in the direction of AB of the vector moment about the point A and equals $\mathbf{r}_1 \times \mathbf{T} \cdot \mathbf{n}$. Similarly the moment of the applied load F about AB is $\mathbf{r}_2 \times \mathbf{F} \cdot \mathbf{n}$. With $CD = \sqrt{46.2}$ m, the vector expressions for \mathbf{T} , \mathbf{F} , \mathbf{r}_1 , and \mathbf{r}_2 are

$$\mathbf{T} = \frac{T}{\sqrt{46.2}}(2\mathbf{i} + 2.5\mathbf{j} - 6\mathbf{k}) \quad \mathbf{F} = 2\mathbf{j} \text{ kN}$$

$$\mathbf{r}_1 = -\mathbf{i} + 2.5\mathbf{j} \text{ m} \quad \mathbf{r}_2 = 2.5\mathbf{i} + 6\mathbf{k} \text{ m}$$

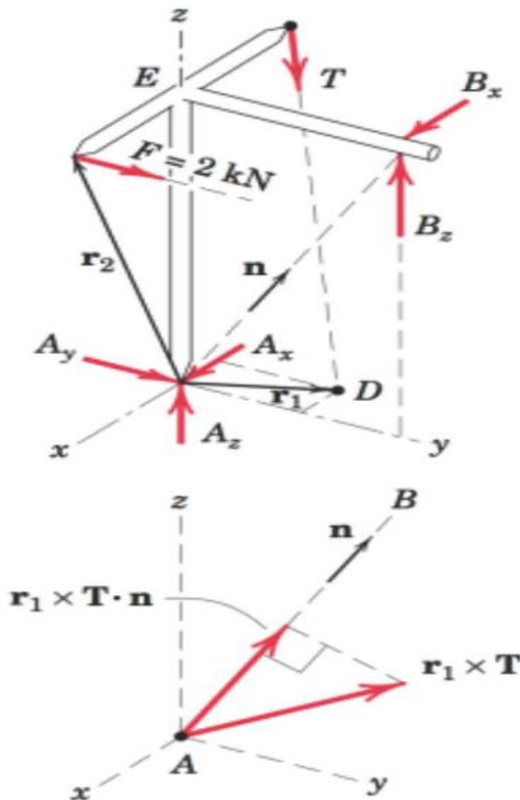
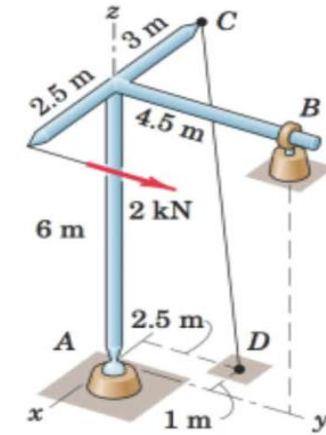

EQUILIBRIUM FREE BODY DIAGRAM (2D)

Example 5.10

The moment equation now becomes

$$[\Sigma M_{AB} = 0] \quad (-\mathbf{i} + 2.5\mathbf{j}) \times \frac{T}{\sqrt{46.2}} (2\mathbf{i} + 2.5\mathbf{j} - 6\mathbf{k}) \cdot \frac{1}{5}(3\mathbf{j} + 4\mathbf{k}) + (2.5\mathbf{i} + 6\mathbf{k}) \times (2\mathbf{j}) \cdot \frac{1}{5}(3\mathbf{j} + 4\mathbf{k}) = 0$$

Completion of the vector operations gives

$$-\frac{48T}{\sqrt{46.2}} + 20 = 0 \quad T = 2.83 \text{ kN} \quad \text{Ans.}$$

and the components of T become

$$T_x = 0.833 \text{ kN} \quad T_y = 1.042 \text{ kN} \quad T_z = -2.50 \text{ kN}$$

We may find the remaining unknowns by moment and force summations as follows:

$$[\Sigma M_z = 0] \quad 2(2.5) - 4.5B_x - 1.042(3) = 0 \quad B_x = 0.417 \text{ kN} \quad \text{Ans.}$$

$$[\Sigma M_x = 0] \quad 4.5B_x - 2(6) - 1.042(6) = 0 \quad B_x = 4.06 \text{ kN} \quad \text{Ans.}$$

$$[\Sigma F_x = 0] \quad A_x + 0.417 + 0.833 = 0 \quad A_x = -1.250 \text{ kN} \quad \text{Ans.}$$

$$[\Sigma F_y = 0] \quad A_y + 2 + 1.042 = 0 \quad A_y = -3.04 \text{ kN} \quad \text{Ans.}$$

$$[\Sigma F_z = 0] \quad A_z + 4.06 - 2.50 = 0 \quad A_z = -1.556 \text{ kN} \quad \text{Ans.}$$

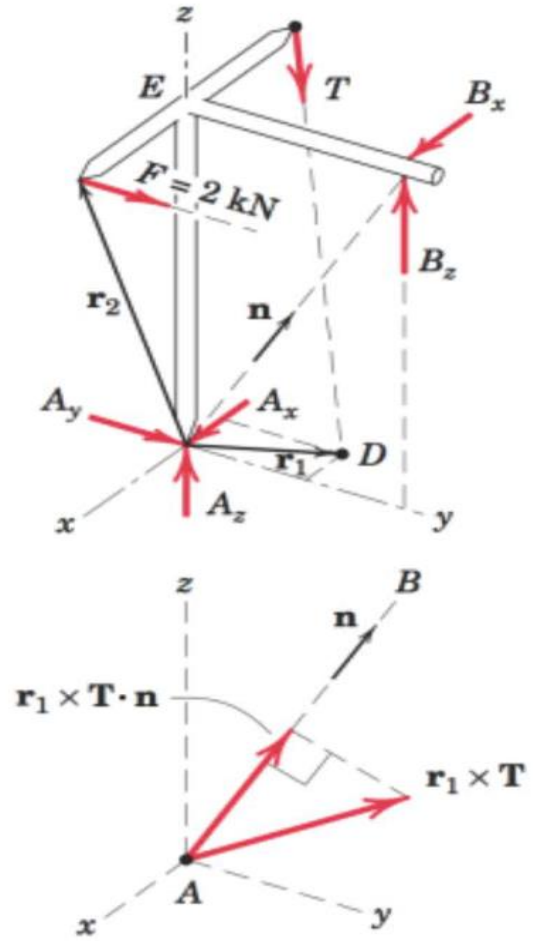
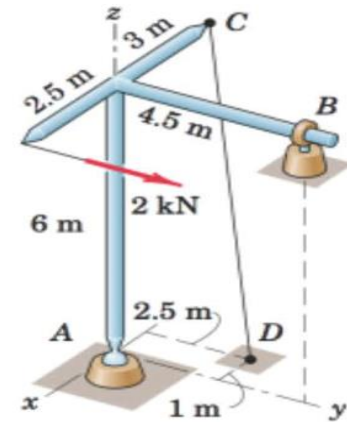

EQUILIBRIUM - FREE BODY DIAGRAM (3D)

Example 5.11

The boom is used to support the 75-lb flowerpot in Fig. 5–30*a*. Determine the tension developed in wires *AB* and *AC*.

SOLUTION (VECTOR ANALYSIS)

Free-Body Diagram. The free-body diagram of the boom is shown in Fig. 5–30*b*.

Equations of Equilibrium. Here the cable forces are directed at angles with the coordinate axes, so we will use a vector analysis.

$$\mathbf{F}_{AB} = F_{AB} \left(\frac{\mathbf{r}_{AB}}{r_{AB}} \right) = F_{AB} \left(\frac{\{2\mathbf{i} - 6\mathbf{j} + 3\mathbf{k}\} \text{ ft}}{\sqrt{(2 \text{ ft})^2 + (-6 \text{ ft})^2 + (3 \text{ ft})^2}} \right)$$

$$= \frac{2}{7} F_{AB} \mathbf{i} - \frac{6}{7} F_{AB} \mathbf{j} + \frac{3}{7} F_{AB} \mathbf{k}$$

$$\mathbf{F}_{AC} = F_{AC} \left(\frac{\mathbf{r}_{AC}}{r_{AC}} \right) = F_{AC} \left(\frac{\{-2\mathbf{i} - 6\mathbf{j} + 3\mathbf{k}\} \text{ ft}}{\sqrt{(-2 \text{ ft})^2 + (-6 \text{ ft})^2 + (3 \text{ ft})^2}} \right)$$

$$= -\frac{2}{7} F_{AC} \mathbf{i} - \frac{6}{7} F_{AC} \mathbf{j} + \frac{3}{7} F_{AC} \mathbf{k}$$

We can eliminate the force reaction at *O* by writing the moment equation of equilibrium about point *O*.

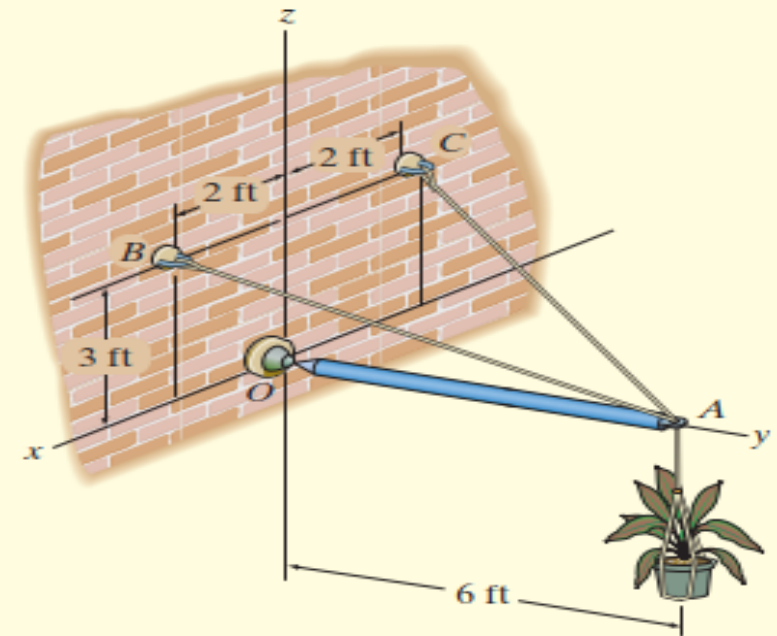

(a)

Fig. 5–30

EQUILIBRIUM FREE BODY DIAGRAM (2D)

Example 5.11

$$\Sigma \mathbf{M}_O = \mathbf{0}; \quad \mathbf{r}_A \times (\mathbf{F}_{AB} + \mathbf{F}_{AC} + \mathbf{W}) = \mathbf{0}$$

$$(6\mathbf{j}) \times \left[\left(\frac{2}{7} F_{AB} \mathbf{i} - \frac{6}{7} F_{AB} \mathbf{j} + \frac{3}{7} F_{AB} \mathbf{k} \right) + \left(-\frac{2}{7} F_{AC} \mathbf{i} - \frac{6}{7} F_{AC} \mathbf{j} + \frac{3}{7} F_{AC} \mathbf{k} \right) + (-75\mathbf{k}) \right] = \mathbf{0}$$

$$\left(\frac{18}{7} F_{AB} + \frac{18}{7} F_{AC} - 450 \right) \mathbf{i} + \left(-\frac{12}{7} F_{AB} + \frac{12}{7} F_{AC} \right) \mathbf{k} = \mathbf{0}$$

$$\Sigma M_x = 0; \quad \frac{18}{7} F_{AB} + \frac{18}{7} F_{AC} - 450 = 0$$

$$\Sigma M_y = 0; \quad 0 = 0$$

$$\Sigma M_z = 0; \quad -\frac{12}{7} F_{AB} + \frac{12}{7} F_{AC} = 0$$

Solving Eqs. (1) and (2) simultaneously,

$$F_{AB} = F_{AC} = 87.5 \text{ lb}$$

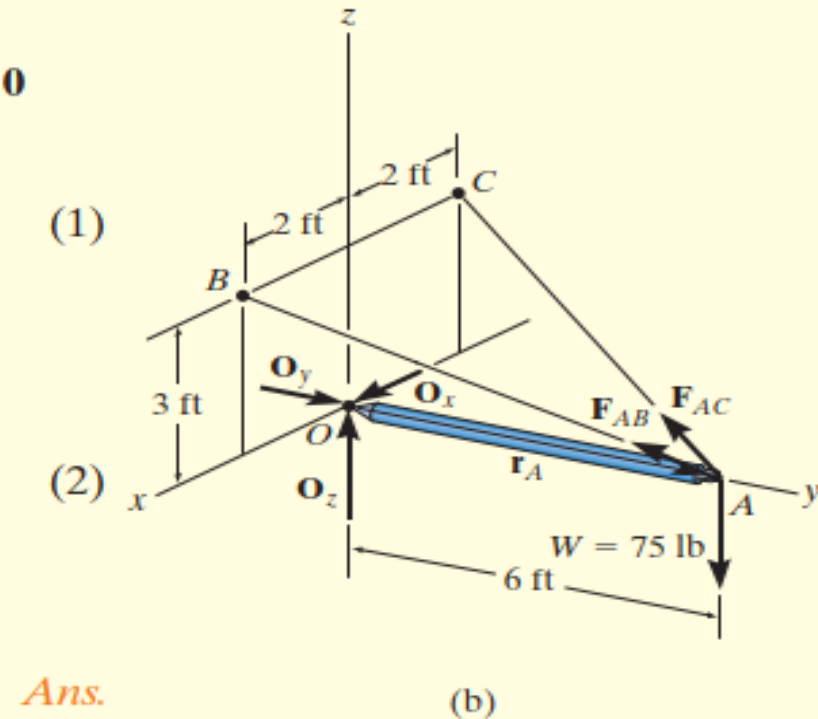



MOMENT OF A COUPLE

HOME WORK EXERCISE

5-10, 5-12, 5-15, 5-20, 5-25, 5-29, 5-42, 5-56, 5-63, 5-64, 5-66, 5-69, 5-73, 5-77 & 5-84.





THE END

THANK YOU

